

APPENDIX R: Traffic Noise

Appendix R-1: Traffic Noise Analysis Report Addendum - Preferred Alternative, August 2023



Traffic Noise Analysis Report Addendum – Preferred Alternative

US 380 McKinney
Coit Road to FM 1827, Collin County
CSJ 0135-02-065, 0135-03-053, and 0135-15-002

Texas Department of Transportation
Dallas District

August 2023

The environmental review, consultation, and other actions required by applicable Federal environmental laws for this project are being, or have been, carried-out by TxDOT pursuant to 23 U.S.C. 327 and a Memorandum of Understanding dated December 9, 2019, and executed by FHWA and TxDOT.

TxDOT Environmental Affairs Division
730.06.TEM

Traffic Noise Analysis Report Addendum – Preferred Alternative

Table of Contents

Introduction.....	2
Abatement Analysis.....	2
Validation	3
Segment A.....	4
Results – Segment A.....	4
Abatement Analysis – Segment A.....	39
Feasible and Reasonable Barriers	39
Barriers Analyzed But Not Proposed	42
Segment C	43
Results – Segment C.....	43
Abatement Analysis – Segment C	47
Barriers Analyzed But Not Proposed	47
Segment E.....	48
Results – Segment E	48
Abatement Analysis – Segment E.....	67
Feasible and Reasonable Barriers	67
Barriers Analyzed But Not Proposed	69
<i>Statement of Likelihood</i>	70
<i>Noise Contours for Land Use Planning</i>	70
<i>Construction Noise</i>	71
<i>Local Official Notification and Date of Public Knowledge Statement</i>	71
<i>List of Attachments</i>	72

List of Figures

Figure 1. Project Overview Map.....	2
-------------------------------------	---

List of Tables

Table 1. Summary of Traffic Noise Impacts for Segment A.....	4
Table 2. Segment A Traffic Noise Levels dB(A) Leq	4
Table 3. Segment A Proposed Noise Barriers.....	39
Table 4. Summary of Traffic Noise Impacts for Segment C	43
Table 5. Segment C Traffic Noise Levels dB(A) Leq.....	44
Table 6. Summary of Traffic Noise Impacts for Segment E.....	48
Table 7. Segment E Traffic Noise Levels dB(A) Leq	48
Table 8. Segment E Proposed Noise Barriers.....	68

Traffic Noise Analysis Report Addendum – Preferred Alternative

Table 9. Summary of Results	70
Table 10. Noise Contours for Land Use Planning	70

List of Attachments

Attachment A – Map Figures

Attachment B – Traffic Figures

Attachment C – Existing Model Validation Study

Attachment D - Ambient Noise Measurements

Traffic Noise Analysis Report Addendum – Preferred Alternative

US 380 MCKINNEY

TxDOT proposes to upgrade US 380 to an eight-lane, access-controlled freeway with two-lane, one-way frontage roads on each side within an anticipated right-of-way width between 350 to 1,580 feet depending on location. Frontage roads may be eliminated, and the primary travel lanes may be depressed/lowered or elevated (on bridge/viaduct) to minimize impacts on sensitive resources. The freeway facility would also include ramps, direct connector roadways, frontage roads, and arterial roadways to support connectivity to the existing roadway network. Grade-separated interchanges would be constructed at major crossroads including US 75/SH 5 (multi-level interchange) and other major local connectors as determined needed and feasible.

The typical freeway section would consist of four 12-foot-wide travel lanes in each direction, 12-foot-wide turn lanes, 10-foot-wide inside shoulders (4-foot-wide may be considered in some locations), and 10-foot-wide outside shoulders. Ramps would be 14 feet-wide with 2-foot-wide inside shoulders and 6-foot-wide outside shoulders, with curb & gutter. Bridges/overpasses along the main lanes would have a desirable vertical clearance of 18.5 feet (minimum of 16.5 feet); vertical clearance over railroads would be 23.5 feet. Ramps, direct connector roadways, frontage roads, and arterial roadway improvements would follow similar design criteria. Median barriers would be included. As final design of the Preferred Alternative/Blue Alternative continues, refinements may be made to further minimize impacts by considering additional or longer bridges and bridge types, location of permanent/ temporary easements, compressing ROW width, locations of depressed/lowered roadway sections, and safety lighting/signage/ITS.

TxDOT has selected the Blue Alternative as the Preferred Alternative for the US 380 McKinney project. The Blue Alternative is comprised of 3 segments, described below connecting the logical termini of Coit Road on the west and FM 1827 on the east:

- Segment A follows existing US 380 from Coit Road to near the approximate alignment of County Road (CR) 161/future Ridge Road where it turns north and connects to existing Bloomdale Road.
- Segment E extends roughly along the alignment of existing Bloomdale Road through north McKinney beginning at the proposed intersection of CR 161/future Ridge Road and Bloomdale Road on the west and to east of SH 5 on the east. This segment includes a new multi-level interchange connection with US 75 and SH 5.
- Segment C begins east of SH 5 extending in a southeasterly direction across the Dallas Area Transit (DART) rail line and the East Fork Trinity River, then shifts to a more southerly direction east of and parallel to the East Fork Trinity River to connect to existing US 380 near FM 1827.

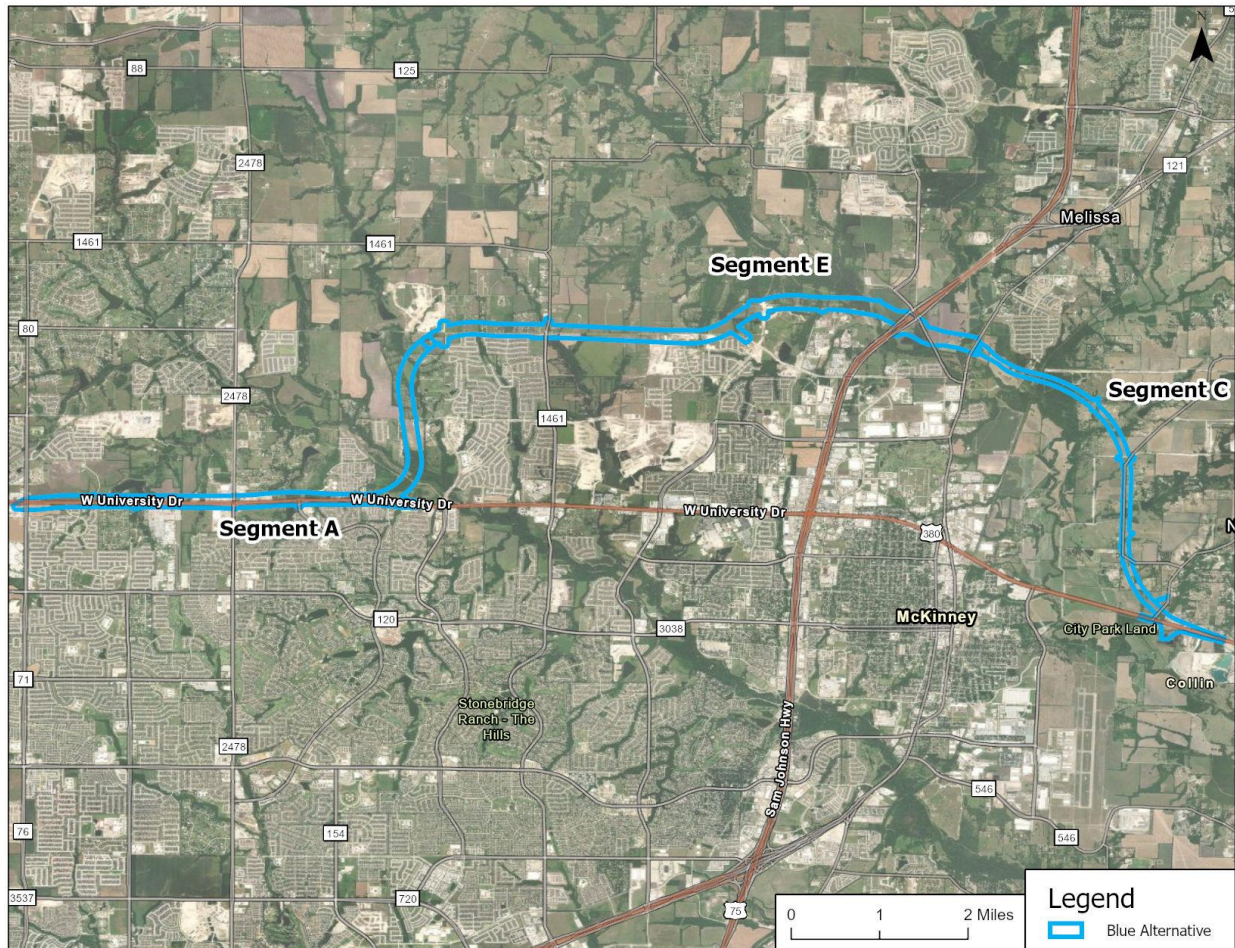
Following the public hearing held on February 16 and February 21, 2023, the design was further refined for the Blue Alternative. This addendum provides the noise modeling updates to the approved Traffic Noise Analysis Report (dated November 2022) for the design refinements for the Blue Alternative. Included among the design refinements are lowering and compressing the roadway in several areas.

The **Blue Alternative** (Segments A+E+C) extends approximately 15.6 miles. The Blue Alternative begins at the intersection of Coit Road and US 380 in the Town of Prosper and travels around the north side of McKinney turning between US 75/SH 5 and existing US 380 east of McKinney where the alignment follows that of Segment C parallel to and east of the East Fork Trinity River. The alignment would connect back to existing US 380 near FM 1827. Grade separations or grade-separated interchanges would be considered at N. Custer Road, the alignment's departure from existing US 380 at future Ridge Road, CR 124/future Wilmeth Road, future Bloomdale Road West, CR 161/future Ridge Road, Lake Forest Drive/FM 1461, future CR 1006, Bloomdale Road East, CR 164/future Hardin Road, Community Avenue, US 75 (multi-level), SH 5, CR 338, and at its connection back to US 380 near FM 1827. Additional and changes to grade-separations and interchange locations may be studied through coordination with the City of McKinney as final design progresses.

Traffic Noise Analysis Report Addendum – Preferred Alternative

Figure 1 shows an overview map of the Project, delineating the segments for the Preferred Alternative.

Figure 1. Project Overview Map



Introduction

The same modeling guidance was followed for this addendum as was applied for the previous TxDOT-approved Traffic Noise Analysis for the US 380 McKinney project.

The approved traffic data used in this analysis is included in **Attachment B**.

As of April 28, 2023, Category B, C, and E receptors include permitted new development for the Town of Prosper and the City of McKinney along the Blue Alternative. Development permits issued after April 28, 2023 were not included in the analysis.

Results are separated by individual segment (Segment A, C, and E) in subsequent report sections.

Abatement Analysis

Before any abatement measure can be proposed for incorporation into the project, it must be both feasible and reasonable. Feasibility and reasonableness considerations include constructability, the predicted acoustic

Traffic Noise Analysis Report Addendum – Preferred Alternative

reductions provided by an abatement measure, a cost allowance, and whether the adjacent receptors desire abatement. Receptors associated with an abatement measure that achieve a noise reduction of five dB(A) or greater are called benefited receptors.

In order to be "feasible," the abatement measure must benefit a minimum of two impacted receptors AND reduce the predicted noise level by at least five dB(A) at greater than 50 percent of first-row impacted receptors. Engineering considerations, such as access, drainage and utility locations, are also factored in the feasibility assessment of a potential noise barrier.

In order to be "reasonable," the abatement measure must also reduce the predicted noise level by at least seven dB(A) for at least one benefited receptor (noise reduction design goal) and not exceed the standard barrier cost of 1,500 square feet per benefited receptor. In addition, an abatement measure may not be reasonable if the construction costs are unreasonably high due to site constraints, as determined through an alternate barrier cost assessment.

The following noise abatement measures were considered: traffic management, alteration of horizontal and/or vertical alignments, acquisition of undeveloped property to act as a buffer zone, and the construction of noise barriers.

Traffic management – Control devices could be used to reduce the speed of the traffic; however, the minor benefit of one dB(A) per five mph reduction in speed does not outweigh the associated increase in congestion and air pollution. Other measures such as time or use restrictions for certain vehicles are prohibited on state highways.

Alteration of horizontal and/or vertical alignments – Any alteration of the existing alignment would displace existing businesses and residences, require additional right of way and not be cost effective/reasonable.

Buffer zone – The acquisition of undeveloped property to act as a buffer zone is designed to avoid rather than abate traffic noise impacts and, therefore, is not feasible.

Noise barriers – Noise barriers in the form of noise walls are the most commonly used noise abatement measures and were considered for this project. Noise barriers were evaluated for each of the impacted receptor locations. The heights of evaluated noise barriers are included in applicable tables, with no barrier exceeding 20 ft in height. For abatement scenarios that feature multiple noise barrier location options, for example at ROW or edge-of-pavement positions, noise barrier naming conventions include a dash ("-") for denoting such alternatives.

Abatement analysis results discussing noise barrier feasibility and reasonableness are separated by individual segment (Segment A, C and E) in subsequent report sections.

Validation

A validation study was performed in order to ensure that traffic noise is the main source of noise and to verify that the existing model accurately predicts existing traffic noise based on current conditions. Model validation compares field-collected sound level measurements to traffic noise levels calculated in an existing condition model that used field-collected traffic parameters. Differences between the measured and calculated levels for this project were within the +/- 3 dB(A) tolerance allowed by FHWA. Therefore, the existing noise model is considered validated for this project. Additional information on the validation study is included in **Attachment C**.

Traffic Noise Analysis Report Addendum – Preferred Alternative

Segment A

Segment A serves as a portion of the western segment of the Preferred Alternative. Segment A follows existing US 380 from Coit Road to near the approximate alignment of future Ridge Road where it turns north and connects to Bloomdale Road.

Results – Segment A

Table 1 provides summary of the traffic noise impacts for Segment A according to evaluated land-use receptors.

Table 1. Summary of Traffic Noise Impacts for Segment A

NAC	RECEPTORS	IMPACTS
A	0	0
B	1273	566
C	56	11
D	0	0
E	0	0
TOTAL	1329	577

Existing and predicted traffic noise levels for Segment A were modeled at receiver locations listed in **Table 2** that represent the land use activity areas adjacent to the proposed project that might be impacted by traffic noise and potentially benefit from feasible and reasonable noise abatement.

Table 2. Segment A Traffic Noise Levels dB(A) Leq

Segment A Representative Receiver	Figure	NAC Category	NAC Level	Existing	Predicted 2050	Change (+/-)	Noise Impact (Yes/No)
R-1	A-1	B-Residential	66	61	59	-2	No
R-3	A-1	B-Residential	66	61	59	-2	No
R-5	A-1	B-Residential	66	61	59	-2	No
R-7	A-1	B-Residential	66	62	61	-1	No
R-9	A-1	B-Residential	66	61	55	-6	No
R-11	A-1	B-Residential	66	61	60	-1	No
R-13	A-1	B-Residential	66	61	60	-1	No
R-15	A-1	B-Residential	66	61	56	-5	No
R-17	A-1	B-Residential	66	61	60	-1	No
R-19	A-1	B-Residential	66	63	61	-2	No
R-21	A-1	B-Residential	66	61	57	-4	No
R-23	A-1	B-Residential	66	63	62	-1	No
R-25	A-1	B-Residential	66	61	60	-1	No
R-27	A-1	B-Residential	66	61	57	-4	No
R-29	A-1	B-Residential	66	63	62	-1	No
R-31	A-1	B-Residential	66	61	61	0	No

Traffic Noise Analysis Report Addendum – Preferred Alternative

Table 2. Segment A Traffic Noise Levels dB(A) Leq

Segment A Representative Receiver	Figure	NAC Category	NAC Level	Existing	Predicted 2050	Change (+/-)	Noise Impact (Yes/No)
R-33	A-1	B-Residential	66	61	59	-2	No
R-35	A-1	B-Residential	66	61	61	0	No
R-37	A-1	B-Residential	66	64	63	-1	No
R-39	A-1	B-Residential	66	61	60	-1	No
R-41	A-1	B-Residential	66	62	61	-1	No
R-43	A-1	B-Residential	66	62	61	-1	No
R-45	A-1	B-Residential	66	64	63	-1	No
R-47	A-1	B-Residential	66	62	61	-1	No
R-49	A-1	B-Residential	66	65	64	-1	No
R-51	A-1	B-Residential	66	68	67	-1	Yes
R-53	A-2	B-Residential	66	62	61	-1	No
R-55	A-2	B-Residential	66	61	59	-2	No
R-57	A-2	B-Residential	66	61	60	-1	No
R-59	A-2	B-Residential	66	64	63	-1	No
R-61	A-2	B-Residential	66	68	67	-1	Yes
R-63	A-2	B-Residential	66	63	63	0	No
R-65	A-2	B-Residential	66	61	60	-1	No
R-67	A-2	B-Residential	66	62	61	-1	No
R-69	A-2	B-Residential	66	61	59	-2	No
R-71	A-2	B-Residential	66	68	66	-2	Yes
R-73	A-2	B-Residential	66	65	63	-2	No
R-75	A-2	B-Residential	66	65	64	-1	No
R-77	A-2	B-Residential	66	64	63	-1	No
R-79	A-2	B-Residential	66	63	61	-2	No
R-81	A-2	B-Residential	66	61	60	-1	No
R-83	A-2	B-Residential	66	61	59	-2	No
R-85	A-2	B-Residential	66	62	61	-1	No
R-87	A-2	B-Residential	66	62	62	0	No
R-89	A-2	B-Residential	66	64	64	0	No
R-91	A-2	B-Residential	66	62	62	0	No
R-93	A-2	B-Residential	66	63	63	0	No
R-95	A-2	B-Residential	66	61	58	-3	No
R-97	A-2	B-Residential	66	61	59	-2	No
R-99	A-2	B-Residential	66	61	59	-2	No
R-101	A-2	B-Residential	66	62	62	0	No
R-103	A-2	B-Residential	66	61	58	-3	No
R-105	A-2	B-Residential	66	62	62	0	No
R-107	A-2	B-Residential	66	65	65	0	No
R-109	A-2	B-Residential	66	64	64	0	No

Traffic Noise Analysis Report Addendum – Preferred Alternative

Table 2. Segment A Traffic Noise Levels dB(A) Leq

Segment A Representative Receiver	Figure	NAC Category	NAC Level	Existing	Predicted 2050	Change (+/-)	Noise Impact (Yes/No)
R-111	A-2	B-Residential	66	62	62	0	No
R-113	A-2	B-Residential	66	62	63	1	No
R-115	A-2	B-Residential	66	62	61	-1	No
R-117	A-2	B-Residential	66	62	60	-2	No
R-119	A-2	B-Residential	66	62	60	-2	No
R-121	A-2	B-Residential	66	62	59	-3	No
R-123	A-2	B-Residential	66	62	60	-2	No
R-125	A-2	B-Residential	66	63	64	1	No
R-127	A-2	B-Residential	66	68	67	-1	Yes
R-129	A-2	B-Residential	66	62	61	-1	No
R-131	A-2	B-Residential	66	67	67	0	Yes
R-133	A-2	B-Residential	66	62	62	0	No
R-135	A-2	B-Residential	66	70	68	-2	Yes
R-137	A-2	B-Residential	66	62	62	0	No
R-139	A-2	B-Residential	66	66	67	1	Yes
R-141	A-2	B-Residential	66	62	63	1	No
R-143	A-2	B-Residential	66	62	63	1	No
R-145	A-2	B-Residential	66	62	64	2	No
R-147	A-2	B-Residential	66	68	70	2	Yes
R-149	A-2	B-Residential	66	62	65	3	No
R-151	A-2	B-Residential	66	62	64	2	No
R-153	A-2	B-Residential	66	62	68	6	Yes
R-155	A-2	B-Residential	66	62	66	4	Yes
R-157	A-2	B-Residential	66	67	71	4	Yes
R-159	A-2	B-Residential	66	63	69	6	Yes
R-161	A-2	B-Residential	66	63	68	5	Yes
R-172	A-3	B-Residential	66	62	63	1	No
R-173	A-3	B-Residential	66	62	62	0	No
R-174	A-3	B-Residential	66	62	61	-1	No
R-175	A-3	B-Residential	66	62	62	0	No
R-176	A-3	B-Residential	66	62	61	-1	No
R-177	A-3	B-Residential	66	62	64	2	No
R-178	A-3	B-Residential	66	62	64	2	No
R-180	A-3	B-Residential	66	62	64	2	No
R-182	A-3	B-Residential	66	62	64	2	No
R-183	A-3	B-Residential	66	62	62	0	No
R-187	A-3	B-Residential	66	62	64	2	No
R-188	A-3	B-Residential	66	62	62	0	No
R-191	A-3	B-Residential	66	62	65	3	No

Traffic Noise Analysis Report Addendum – Preferred Alternative

Table 2. Segment A Traffic Noise Levels dB(A) Leq

Segment A Representative Receiver	Figure	NAC Category	NAC Level	Existing	Predicted 2050	Change (+/-)	Noise Impact (Yes/No)
R-193	A-3	B-Residential	66	62	62	0	No
R-195	A-3	B-Residential	66	62	65	3	No
R-196	A-3	B-Residential	66	62	62	0	No
R-198	A-3	B-Residential	66	62	63	1	No
R-200	A-3	B-Residential	66	62	65	3	No
R-201	A-3	B-Residential	66	62	63	1	No
R-202	A-3	B-Residential	66	62	65	3	No
R-206	A-3	B-Residential	66	62	65	3	No
R-207	A-3	B-Residential	66	62	63	1	No
R-208	A-3	B-Residential	66	62	65	3	No
R-209	A-3	B-Residential	66	62	63	1	No
R-211	A-3	B-Residential	66	62	65	3	No
R-212	A-3	B-Residential	66	62	63	1	No
R-217	A-3	B-Residential	66	62	63	1	No
R-219	A-4	C-Pool	66	62	65	3	No
R-220	A-3	B-Residential	66	62	63	1	No
R-222	A-3	B-Residential	66	62	63	1	No
R-225	A-3	B-Residential	66	62	66	4	Yes
R-226	A-3	B-Residential	66	62	63	1	No
R-229	A-3	B-Residential	66	62	63	1	No
R-231	A-3	B-Residential	66	62	66	4	Yes
R-232	A-3	B-Residential	66	62	63	1	No
R-237	A-3	B-Residential	66	62	66	4	Yes
R-241	A-3	B-Residential	66	62	66	4	Yes
R-242	A-3	B-Residential	66	62	61	-1	No
R-243	A-3	B-Residential	66	62	66	4	Yes
R-244	A-3	B-Residential	66	62	62	0	No
R-245	A-3	B-Residential	66	62	63	1	No
R-246	A-3	B-Residential	66	62	64	2	No
R-455	A-5	B-Residential	66	62	64	2	No
R-458	A-5	B-Residential	66	62	62	0	No
R-461	A-5	B-Residential	66	62	64	2	No
R-462	A-5	B-Residential	66	62	61	-1	No
R-465	A-6	B-Residential	66	62	63	1	No
R-466	A-6	B-Residential	66	62	69	7	Yes
R-467	A-6	B-Residential	66	62	61	-1	No
R-468	A-6	B-Residential	66	62	64	2	No
R-469	A-7	C-Park Bench	66	62	56	-6	No
R-470	A-7	C-Park Bench	66	62	56	-6	No

Traffic Noise Analysis Report Addendum – Preferred Alternative

Table 2. Segment A Traffic Noise Levels dB(A) Leq

Segment A Representative Receiver	Figure	NAC Category	NAC Level	Existing	Predicted 2050	Change (+/-)	Noise Impact (Yes/No)
R-471	A-7	C-Public and Private Parks/Open Spaces	66	62	60	-2	No
R-472	A-7	C-Picnic areas	66	62	59	-3	No
R-473	A-7	C-Picnic areas	66	62	60	-2	No
R-474	A-6	C-Public and Private Parks/Open Spaces	66	62	66	4	Yes
R-475	A-6	C-Picnic areas	66	62	63	1	No
R-476	A-6	C-Picnic areas	66	62	63	1	No
R-477	A-6	C-Public and Private Parks/Open Spaces	66	69	70	1	Yes
R-478	A-6	B-Residential	66	69	65	-4	No
R-479	A-6	B-Residential	66	69	65	-4	No
R-480	A-6	B-Residential	66	69	64	-5	No
R-481	A-6	B-Residential	66	69	64	-5	No
R-482	A-6	B-Residential	66	69	62	-7	No
R-483	A-6	B-Residential	66	69	67	-2	Yes
R-484	A-6	B-Residential	66	69	62	-7	No
R-485	A-6	B-Residential	66	69	67	-2	Yes
R-486	A-6	B-Residential	66	69	61	-8	No
R-487	A-6	B-Residential	66	69	64	-5	No
R-488	A-6	B-Residential	66	69	62	-7	No
R-489	A-6	B-Residential	66	69	67	-2	Yes
R-490	A-6	B-Residential	66	69	63	-6	No
R-491	A-6	B-Residential	66	69	62	-7	No
R-492	A-6	B-Residential	66	69	66	-3	Yes
R-493	A-6	B-Residential	66	69	60	-9	No
R-494	A-6	B-Residential	66	69	63	-6	No
R-495	A-6	B-Residential	66	69	62	-7	No
R-496	A-6	B-Residential	66	69	65	-4	No
R-497	A-6	B-Residential	66	69	63	-6	No
R-498	A-6	B-Residential	66	69	65	-4	No
R-499	A-6	B-Residential	66	69	62	-7	No
R-500	A-6	B-Residential	66	69	60	-9	No
R-501	A-6	B-Residential	66	69	63	-6	No
R-502	A-6	B-Residential	66	69	64	-5	No

Traffic Noise Analysis Report Addendum – Preferred Alternative

Table 2. Segment A Traffic Noise Levels dB(A) Leq

Segment A Representative Receiver	Figure	NAC Category	NAC Level	Existing	Predicted 2050	Change (+/-)	Noise Impact (Yes/No)
R-503	A-6	B-Residential	66	69	61	-8	No
R-504	A-6	B-Residential	66	69	60	-9	No
R-505	A-6	B-Residential	66	69	63	-6	No
R-506	A-6	B-Residential	66	69	61	-8	No
R-507	A-6	B-Residential	66	69	63	-6	No
R-508	A-6	B-Residential	66	69	60	-9	No
R-509	A-6	B-Residential	66	69	62	-7	No
R-510	A-6	B-Residential	66	69	61	-8	No
R-511	A-6	B-Residential	66	69	63	-6	No
R-512	A-6	B-Residential	66	69	59	-10	No
R-513	A-6	B-Residential	66	69	62	-7	No
R-514	A-6	B-Residential	66	69	61	-8	No
R-515	A-6	B-Residential	66	69	63	-6	No
R-516	A-6	B-Residential	66	60	63	3	No
R-517	A-6	B-Residential	66	69	59	-10	No
R-518	A-6	B-Residential	66	69	61	-8	No
R-519	A-6	B-Residential	66	69	60	-9	No
R-520	A-6	B-Residential	66	69	63	-6	No
R-521	A-6	B-Residential	66	69	61	-8	No
R-522	A-6	B-Residential	66	69	60	-9	No
R-523	A-6	B-Residential	66	69	59	-10	No
R-524	A-6	B-Residential	66	69	63	-6	No
R-525	A-6	B-Residential	66	69	60	-9	No
R-526	A-6	B-Residential	66	69	62	-7	No
R-527	A-6	B-Residential	66	69	59	-10	No
R-528	A-6	B-Residential	66	69	59	-10	No
R-529	A-8	B-Residential	66	69	59	-10	No
R-530	A-8	B-Residential	66	69	58	-11	No
R-531	A-8	B-Residential	66	69	62	-7	No
R-532	A-8	B-Residential	66	69	61	-8	No
R-533	A-8	B-Residential	66	69	59	-10	No
R-534	A-8	B-Residential	66	69	60	-9	No
R-535	A-8	B-Residential	66	69	60	-9	No
R-536	A-8	B-Residential	66	69	60	-9	No
R-537	A-8	B-Residential	66	69	59	-10	No
R-538	A-8	B-Residential	66	69	60	-9	No
R-539	A-8	B-Residential	66	59	60	1	No
R-540	A-8	B-Residential	66	69	60	-9	No
R-541	A-8	B-Residential	66	69	60	-9	No

Traffic Noise Analysis Report Addendum – Preferred Alternative

Table 2. Segment A Traffic Noise Levels dB(A) Leq

Segment A Representative Receiver	Figure	NAC Category	NAC Level	Existing	Predicted 2050	Change (+/-)	Noise Impact (Yes/No)
R-542	A-8	B-Residential	66	69	60	-9	No
R-543	A-8	B-Residential	66	59	60	1	No
R-544	A-8	B-Residential	66	69	59	-10	No
R-545	A-8	B-Residential	66	69	60	-9	No
R-546	A-8	B-Residential	66	69	60	-9	No
R-547	A-8	B-Residential	66	69	60	-9	No
R-548	A-8	B-Residential	66	59	61	2	No
R-549	A-8	B-Residential	66	60	61	1	No
R-550	A-8	B-Residential	66	60	61	1	No
R-551	A-8	B-Residential	66	61	61	0	No
R-552	A-8	B-Residential	66	62	61	-1	No
R-553	A-8	B-Residential	66	61	63	2	No
R-554	A-8	B-Residential	66	63	62	-1	No
R-555	A-8	B-Residential	66	69	58	-11	No
R-556	A-8	B-Residential	66	69	59	-10	No
R-557	A-8	B-Residential	66	69	60	-9	No
R-558	A-8	B-Residential	66	69	60	-9	No
R-559	A-8	B-Residential	66	63	62	-1	No
R-560	A-8	B-Residential	66	61	62	1	No
R-561	A-8	B-Residential	66	62	64	2	No
R-562	A-8	B-Residential	66	64	62	-2	No
R-563	A-8	B-Residential	66	62	64	2	No
R-564	A-8	B-Residential	66	69	62	-7	No
R-565	A-8	B-Residential	66	59	59	0	No
R-566	A-8	B-Residential	66	69	61	-8	No
R-567	A-8	B-Residential	66	69	60	-9	No
R-568	A-8	B-Residential	66	64	61	-3	No
R-569	A-8	B-Residential	66	69	59	-10	No
R-570	A-8	B-Residential	66	69	59	-10	No
R-571	A-8	B-Residential	66	69	58	-11	No
R-572	A-8	B-Residential	66	62	64	2	No
R-573	A-8	B-Residential	66	69	66	-3	Yes
R-574	A-8	B-Residential	66	59	58	-1	No
R-575	A-8	B-Residential	66	62	60	-2	No
R-576	A-8	B-Residential	66	62	64	2	No
R-577	A-8	B-Residential	66	59	58	-1	No
R-578	A-8	B-Residential	66	69	64	-5	No
R-579	A-8	B-Residential	66	59	58	-1	No
R-580	A-8	B-Residential	66	69	59	-10	No

Traffic Noise Analysis Report Addendum – Preferred Alternative

Table 2. Segment A Traffic Noise Levels dB(A) Leq

Segment A Representative Receiver	Figure	NAC Category	NAC Level	Existing	Predicted 2050	Change (+/-)	Noise Impact (Yes/No)
R-581	A-8	B-Residential	66	69	62	-7	No
R-582	A-8	B-Residential	66	69	64	-5	No
R-583	A-8	B-Residential	66	69	62	-7	No
R-584	A-8	B-Residential	66	69	59	-10	No
R-585	A-8	B-Residential	66	69	61	-8	No
R-586	A-8	B-Residential	66	69	63	-6	No
R-587	A-8	B-Residential	66	69	60	-9	No
R-588	A-8	B-Residential	66	60	61	1	No
R-589	A-8	B-Residential	66	59	59	0	No
R-590	A-8	B-Residential	66	59	58	-1	No
R-591	A-8	B-Residential	66	69	59	-10	No
R-592	A-8	B-Residential	66	69	57	-12	No
R-593	A-8	B-Residential	66	59	58	-1	No
R-594	A-8	B-Residential	66	69	62	-7	No
R-595	A-8	B-Residential	66	69	60	-9	No
R-596	A-8	B-Residential	66	59	57	-2	No
R-597	A-8	B-Residential	66	69	62	-7	No
R-598	A-8	B-Residential	66	69	61	-8	No
R-599	A-8	B-Residential	66	69	62	-7	No
R-600	A-8	B-Residential	66	69	61	-8	No
R-601	A-8	B-Residential	66	69	62	-7	No
R-602	A-8	B-Residential	66	69	59	-10	No
R-603	A-8	B-Residential	66	69	60	-9	No
R-604	A-8	B-Residential	66	69	62	-7	No
R-605	A-8	B-Residential	66	69	58	-11	No
R-606	A-8	B-Residential	66	69	56	-13	No
R-607	A-8	B-Residential	66	69	58	-11	No
R-608	A-8	B-Residential	66	69	61	-8	No
R-609	A-8	B-Residential	66	69	57	-12	No
R-610	A-8	B-Residential	66	69	62	-7	No
R-611	A-8	B-Residential	66	69	65	-4	No
R-612	A-8	B-Residential	66	69	60	-9	No
R-613	A-8	B-Residential	66	69	59	-10	No
R-614	A-8	B-Residential	66	69	58	-11	No
R-615	A-8	B-Residential	66	69	57	-12	No
R-616	A-8	B-Residential	66	69	61	-8	No
R-617	A-8	C-Daycare	66	69	57	-12	No
R-618	A-8	C-Pool	66	59	58	-1	No
R-619	A-8	C-Daycare	66	69	59	-10	No

Traffic Noise Analysis Report Addendum – Preferred Alternative

Table 2. Segment A Traffic Noise Levels dB(A) Leq

Segment A Representative Receiver	Figure	NAC Category	NAC Level	Existing	Predicted 2050	Change (+/-)	Noise Impact (Yes/No)
R-620	A-8	C-Daycare	66	69	60	-9	No
R-621	A-8	C-Daycare	66	69	58	-11	No
R-622	A-9	B-Residential	66	70	61	-9	No
R-623	A-9	B-Residential	66	70	63	-7	No
R-624	A-9	B-Residential	66	70	63	-7	No
R-625	A-9	B-Residential	66	70	65	-5	No
R-626	A-9	B-Residential	66	70	62	-8	No
R-627	A-9	B-Residential	66	70	64	-6	No
R-628	A-9	B-Residential	66	70	63	-7	No
R-629	A-9	B-Residential	66	70	64	-6	No
R-630	A-9	B-Residential	66	70	63	-7	No
R-631	A-9	B-Residential	66	70	64	-6	No
R-632	A-9	B-Residential	66	70	64	-6	No
R-633	A-9	B-Residential	66	70	65	-5	No
R-634	A-9	B-Residential	66	70	62	-8	No
R-635	A-9	B-Residential	66	70	63	-7	No
R-636	A-9	B-Residential	66	70	62	-8	No
R-637	A-9	B-Residential	66	70	64	-6	No
R-638	A-9	B-Residential	66	70	69	-1	Yes
R-639	A-9	B-Residential	66	70	71	1	Yes
R-640	A-9	B-Residential	66	70	67	-3	Yes
R-641	A-9	B-Residential	66	70	69	-1	Yes
R-642	A-9	B-Residential	66	70	68	-2	Yes
R-643	A-9	B-Residential	66	70	70	0	Yes
R-644	A-9	B-Residential	66	70	69	-1	Yes
R-645	A-9	B-Residential	66	70	71	1	Yes
R-646	A-9	B-Residential	66	70	69	-1	Yes
R-647	A-9	B-Residential	66	70	71	1	Yes
R-648	A-9	B-Residential	66	70	68	-2	Yes
R-649	A-9	B-Residential	66	70	70	0	Yes
R-650	A-9	B-Residential	66	70	64	-6	No
R-651	A-9	B-Residential	66	70	65	-5	No
R-652	A-9	B-Residential	66	70	66	-4	Yes
R-653	A-9	B-Residential	66	70	65	-5	No
R-654	A-9	B-Residential	66	70	62	-8	No
R-655	A-9	B-Residential	66	70	64	-6	No
R-656	A-9	B-Residential	66	70	63	-7	No
R-657	A-9	B-Residential	66	70	65	-5	No
R-658	A-9	B-Residential	66	70	66	-4	Yes

Traffic Noise Analysis Report Addendum – Preferred Alternative

Table 2. Segment A Traffic Noise Levels dB(A) Leq

Segment A Representative Receiver	Figure	NAC Category	NAC Level	Existing	Predicted 2050	Change (+/-)	Noise Impact (Yes/No)
R-659	A-9	B-Residential	66	70	62	-8	No
R-660	A-9	B-Residential	66	70	63	-7	No
R-661	A-9	B-Residential	66	70	64	-6	No
R-662	A-9	B-Residential	66	70	69	-1	Yes
R-663	A-9	B-Residential	66	70	71	1	Yes
R-664	A-9	B-Residential	66	70	68	-2	Yes
R-665	A-9	B-Residential	66	70	70	0	Yes
R-666	A-9	B-Residential	66	70	64	-6	No
R-667	A-9	B-Residential	66	70	65	-5	No
R-668	A-9	B-Residential	66	70	66	-4	Yes
R-669	A-9	B-Residential	66	70	62	-8	No
R-670	A-9	B-Residential	66	70	63	-7	No
R-671	A-9	B-Residential	66	70	64	-6	No
R-672	A-9	B-Residential	66	70	65	-5	No
R-673	A-9	B-Residential	66	70	62	-8	No
R-674	A-9	B-Residential	66	70	64	-6	No
R-675	A-9	B-Residential	66	70	63	-7	No
R-676	A-9	B-Residential	66	70	65	-5	No
R-677	A-9	B-Residential	66	70	66	-4	Yes
R-678	A-9	C-Pool	66	70	66	-4	Yes
R-679	A-9	B-Residential	66	70	65	-5	No
R-680	A-9	B-Residential	66	70	67	-3	Yes
R-681	A-9	B-Residential	66	70	68	-2	Yes
R-682	A-9	B-Residential	66	70	70	0	Yes
R-683	A-9	B-Residential	66	70	66	-4	Yes
R-684	A-9	B-Residential	66	70	68	-2	Yes
R-685	A-9	B-Residential	66	70	67	-3	Yes
R-686	A-9	B-Residential	66	70	69	-1	Yes
R-687	A-9	B-Residential	66	70	64	-6	No
R-688	A-9	B-Residential	66	70	66	-4	Yes
R-689	A-9	B-Residential	66	70	67	-3	Yes
R-690	A-9	B-Residential	66	70	65	-5	No
R-691	A-9	B-Residential	66	70	61	-9	No
R-692	A-9	B-Residential	66	70	63	-7	No
R-693	A-9	B-Residential	66	70	66	-4	Yes
R-694	A-9	B-Residential	66	70	63	-7	No
R-695	A-9	B-Residential	66	70	65	-5	No
R-696	A-9	B-Residential	66	70	62	-8	No
R-697	A-9	B-Residential	66	70	64	-6	No

Traffic Noise Analysis Report Addendum – Preferred Alternative

Table 2. Segment A Traffic Noise Levels dB(A) Leq

Segment A Representative Receiver	Figure	NAC Category	NAC Level	Existing	Predicted 2050	Change (+/-)	Noise Impact (Yes/No)
R-698	A-9	B-Residential	66	70	65	-5	No
R-699	A-9	B-Residential	66	70	66	-4	Yes
R-700	A-9	B-Residential	66	70	68	-2	Yes
R-701	A-9	B-Residential	66	70	66	-4	Yes
R-702	A-9	B-Residential	66	70	69	-1	Yes
R-703	A-9	B-Residential	66	70	65	-5	No
R-704	A-9	B-Residential	66	70	67	-3	Yes
R-705	A-9	B-Residential	66	70	67	-3	Yes
R-706	A-9	B-Residential	66	70	70	0	Yes
R-707	A-9	B-Residential	66	70	62	-8	No
R-708	A-9	B-Residential	66	70	64	-6	No
R-709	A-9	B-Residential	66	70	66	-4	Yes
R-710	A-9	B-Residential	66	70	61	-9	No
R-711	A-9	B-Residential	66	70	64	-6	No
R-712	A-9	B-Residential	66	70	65	-5	No
R-713	A-9	B-Residential	66	70	63	-7	No
R-714	A-9	B-Residential	66	70	65	-5	No
R-715	A-9	B-Residential	66	70	67	-3	Yes
R-716	A-9	B-Residential	66	70	60	-10	No
R-717	A-9	B-Residential	66	70	63	-7	No
R-718	A-9	B-Residential	66	70	64	-6	No
R-719	A-9	B-Residential	66	70	67	-3	Yes
R-720	A-9	B-Residential	66	70	69	-1	Yes
R-721	A-9	B-Residential	66	70	64	-6	No
R-722	A-9	B-Residential	66	70	67	-3	Yes
R-723	A-9	B-Residential	66	70	63	-7	No
R-724	A-9	B-Residential	66	70	65	-5	No
R-725	A-9	B-Residential	66	70	67	-3	Yes
R-726	A-9	B-Residential	66	70	65	-5	No
R-727	A-9	B-Residential	66	70	68	-2	Yes
R-728	A-9	B-Residential	66	70	66	-4	Yes
R-729	A-9	B-Residential	66	70	68	-2	Yes
R-730	A-9	B-Residential	66	70	66	-4	Yes
R-731	A-9	B-Residential	66	70	62	-8	No
R-732	A-9	B-Residential	66	70	64	-6	No
R-733	A-9	B-Residential	66	70	60	-10	No
R-734	A-9	B-Residential	66	70	63	-7	No
R-735	A-9	B-Residential	66	70	64	-6	No
R-736	A-9	B-Residential	66	70	61	-9	No

Traffic Noise Analysis Report Addendum – Preferred Alternative

Table 2. Segment A Traffic Noise Levels dB(A) Leq

Segment A Representative Receiver	Figure	NAC Category	NAC Level	Existing	Predicted 2050	Change (+/-)	Noise Impact (Yes/No)
R-737	A-9	B-Residential	66	70	64	-6	No
R-738	A-9	B-Residential	66	70	65	-5	No
R-739	A-9	B-Residential	66	70	65	-5	No
R-740	A-9	B-Residential	66	70	68	-2	Yes
R-741	A-9	B-Residential	66	70	65	-5	No
R-742	A-9	B-Residential	66	70	67	-3	Yes
R-743	A-9	B-Residential	66	70	62	-8	No
R-744	A-9	B-Residential	66	70	64	-6	No
R-745	A-9	B-Residential	66	70	66	-4	Yes
R-746	A-9	B-Residential	66	70	63	-7	No
R-747	A-9	B-Residential	66	70	65	-5	No
R-748	A-9	B-Residential	66	70	66	-4	Yes
R-749	A-9	B-Residential	66	70	61	-9	No
R-750	A-9	B-Residential	66	70	63	-7	No
R-751	A-9	B-Residential	66	70	65	-5	No
R-752	A-9	B-Residential	66	70	65	-5	No
R-753	A-9	B-Residential	66	70	69	-1	Yes
R-754	A-9	B-Residential	66	70	64	-6	No
R-755	A-9	B-Residential	66	70	66	-4	Yes
R-756	A-9	B-Residential	66	70	61	-9	No
R-757	A-9	B-Residential	66	70	63	-7	No
R-758	A-9	B-Residential	66	70	64	-6	No
R-759	A-9	B-Residential	66	70	59	-11	No
R-760	A-9	B-Residential	66	70	61	-9	No
R-761	A-9	B-Residential	66	70	62	-8	No
R-762	A-9	B-Residential	66	70	62	-8	No
R-763	A-9	B-Residential	66	70	64	-6	No
R-764	A-9	B-Residential	66	70	66	-4	Yes
R-765	A-9	B-Residential	66	70	61	-9	No
R-766	A-9	B-Residential	66	70	63	-7	No
R-767	A-9	B-Residential	66	70	64	-6	No
R-768	A-9	B-Residential	66	70	62	-8	No
R-769	A-9	B-Residential	66	70	64	-6	No
R-770	A-9	B-Residential	66	70	65	-5	No
R-771	A-9	B-Residential	66	70	61	-9	No
R-772	A-9	B-Residential	66	70	63	-7	No
R-773	A-9	B-Residential	66	70	64	-6	No
R-774	A-9	B-Residential	66	70	59	-11	No
R-775	A-9	B-Residential	66	70	61	-9	No

Traffic Noise Analysis Report Addendum – Preferred Alternative

Table 2. Segment A Traffic Noise Levels dB(A) Leq

Segment A Representative Receiver	Figure	NAC Category	NAC Level	Existing	Predicted 2050	Change (+/-)	Noise Impact (Yes/No)
R-776	A-9	B-Residential	66	70	62	-8	No
R-777	A-9	B-Residential	66	70	65	-5	No
R-778	A-9	B-Residential	66	70	61	-9	No
R-779	A-9	B-Residential	66	70	64	-6	No
R-780	A-9	B-Residential	66	70	61	-9	No
R-781	A-9	B-Residential	66	70	63	-7	No
R-782	A-9	B-Residential	66	70	64	-6	No
R-783	A-9	B-Residential	66	70	60	-10	No
R-784	A-9	B-Residential	66	70	63	-7	No
R-785	A-9	B-Residential	66	70	63	-7	No
R-786	A-9	B-Residential	66	70	60	-10	No
R-787	A-9	B-Residential	66	70	63	-7	No
R-788	A-9	B-Residential	66	70	64	-6	No
R-789	A-8	B-Residential	66	70	58	-12	No
R-790	A-8	B-Residential	66	70	58	-12	No
R-791	A-8	B-Residential	66	70	59	-11	No
R-792	A-8	B-Residential	66	70	59	-11	No
R-793	A-8	B-Residential	66	70	60	-10	No
R-794	A-8	B-Residential	66	70	59	-11	No
R-795	A-8	B-Residential	66	70	59	-11	No
R-796	A-8	B-Residential	66	70	61	-9	No
R-797	A-8	B-Residential	66	70	62	-8	No
R-798	A-8	B-Residential	66	70	57	-13	No
R-799	A-8	B-Residential	66	70	60	-10	No
R-800	A-8	B-Residential	66	70	57	-13	No
R-801	A-8	B-Residential	66	70	63	-7	No
R-802	A-8	B-Residential	66	70	59	-11	No
R-803	A-8	B-Residential	66	70	59	-11	No
R-804	A-8	B-Residential	66	70	60	-10	No
R-805	A-8	B-Residential	66	70	57	-13	No
R-806	A-8	B-Residential	66	70	63	-7	No
R-807	A-8	B-Residential	66	70	58	-12	No
R-808	A-8	B-Residential	66	70	60	-10	No
R-809	A-8	B-Residential	66	70	64	-6	No
R-810	A-8	B-Residential	66	70	58	-12	No
R-811	A-8	B-Residential	66	70	59	-11	No
R-812	A-8	B-Residential	66	70	58	-12	No
R-813	A-8	B-Residential	66	70	64	-6	No
R-814	A-8	B-Residential	66	70	59	-11	No

Traffic Noise Analysis Report Addendum – Preferred Alternative

Table 2. Segment A Traffic Noise Levels dB(A) Leq

Segment A Representative Receiver	Figure	NAC Category	NAC Level	Existing	Predicted 2050	Change (+/-)	Noise Impact (Yes/No)
R-815	A-8	B-Residential	66	70	65	-5	No
R-816	A-8	B-Residential	66	70	59	-11	No
R-817	A-13	B-Residential	66	47	62	15	Yes
R-818	A-8	B-Residential	66	70	66	-4	Yes
R-819	A-13	B-Residential	66	46	63	17	Yes
R-820	A-8	B-Residential	66	70	66	-4	Yes
R-821	A-8	B-Residential	66	70	66	-4	Yes
R-822	A-13	B-Residential	66	46	67	21	Yes
R-823	A-10	C-Hospital	66	70	60	-10	No
R-824	A-10	C-Hospital	66	70	61	-9	No
R-825	A-10	C-Hospital	66	70	64	-6	No
R-826	A-10	C-Hospital	66	70	63	-7	No
R-827	A-10	C-Hospital	66	70	65	-5	No
R-828	A-10	C-Hospital	66	70	62	-8	No
R-829	A-10	C-Hospital	66	70	65	-5	No
R-830	A-10	C-Hospital	66	70	63	-7	No
R-831	A-10	C-Hospital	66	70	63	-7	No
R-832	A-10	C-Hospital	66	70	61	-9	No
R-833	A-10	C-Hospital	66	70	65	-5	No
R-834	A-10	C-Hospital	66	70	63	-7	No
R-835	A-10	C-Hospital	66	70	63	-7	No
R-836	A-10	C-Hospital	66	70	61	-9	No
R-837	A-10	C-Hospital	66	70	66	-4	Yes
R-838	A-10	C-Hospital	66	70	64	-6	No
R-839	A-10	C-Hospital	66	70	63	-7	No
R-840	A-10	C-Hospital	66	70	61	-9	No
R-841	A-10	C-Hospital	66	70	64	-6	No
R-842	A-10	C-Hospital	66	70	62	-8	No
R-843	A-10	C-Hospital	66	70	65	-5	No
R-844	A-10	C-Hospital	66	70	63	-7	No
R-845	A-10	B-Residential	66	70	60	-10	No
R-846	A-10	C-Hospital	66	70	65	-5	No
R-847	A-10	C-Hospital	66	70	64	-6	No
R-848	A-10	C-Hospital	66	70	63	-7	No
R-849	A-10	C-Hospital	66	70	62	-8	No
R-850	A-10	C-Hospital	66	70	64	-6	No
R-851	A-10	C-Hospital	66	70	62	-8	No
R-852	A-10	C-Hospital	66	70	65	-5	No
R-853	A-10	C-Hospital	66	70	63	-7	No

Traffic Noise Analysis Report Addendum – Preferred Alternative

Table 2. Segment A Traffic Noise Levels dB(A) Leq

Segment A Representative Receiver	Figure	NAC Category	NAC Level	Existing	Predicted 2050	Change (+/-)	Noise Impact (Yes/No)
R-854	A-10	B-Residential	66	70	60	-10	No
R-855	A-10	B-Residential	66	70	60	-10	No
R-856	A-10	B-Residential	66	70	60	-10	No
R-857	A-10	B-Residential	66	70	60	-10	No
R-858	A-10	B-Residential	66	70	60	-10	No
R-860	A-10	B-Residential	66	70	60	-10	No
R-863	A-16	B-Residential	66	46	60	14	Yes
R-867	A-10	B-Residential	66	70	60	-10	No
R-870	A-10	B-Residential	66	70	60	-10	No
R-873	A-10	B-Residential	66	70	60	-10	No
R-877	A-10	B-Residential	66	70	60	-10	No
R-881	A-10	B-Residential	66	70	60	-10	No
R-884	A-16	B-Residential	66	46	59	13	Yes
R-887	A-10	B-Residential	66	70	60	-10	No
R-894	A-17	B-Residential	66	55	66	11	Yes
R-900	A-14	C-Park	66	46	62	16	Yes
R-901	A-14	C-Park	66	46	61	15	Yes
R-912	A-16	B-Residential	66	46	64	18	Yes
R-918	A-14	C-Park	66	46	59	13	Yes
R-919	A-14	C-Park	66	46	59	13	Yes
R-925	A-14	C-Park	66	46	59	13	Yes
R-939	A-14	C-Park	66	46	57	11	Yes
R-946	A-14	C-Park	66	46	57	11	Yes
R-948	A-16	B-Residential	66	46	56	10	No
R-971	A-14	C-Park	66	46	56	10	No
R-975	A-14	C-Park	66	46	56	10	No
R-1527	A-11	B-Residential	66	70	68	-2	Yes
R-1528	A-11	B-Residential	66	70	71	1	Yes
R-1529	A-11	B-Residential	66	70	73	3	Yes
R-1530	A-11	B-Residential	66	70	74	4	Yes
R-1531	A-11	B-Residential	66	70	68	-2	Yes
R-1532	A-11	B-Residential	66	70	71	1	Yes
R-1533	A-11	B-Residential	66	70	72	2	Yes
R-1534	A-11	B-Residential	66	70	68	-2	Yes
R-1535	A-11	B-Residential	66	70	70	0	Yes
R-1536	A-11	B-Residential	66	70	72	2	Yes
R-1537	A-11	B-Residential	66	70	72	2	Yes
R-1538	A-11	B-Residential	66	70	73	3	Yes
R-1539	A-11	B-Residential	66	70	69	-1	Yes

Traffic Noise Analysis Report Addendum – Preferred Alternative

Table 2. Segment A Traffic Noise Levels dB(A) Leq

Segment A Representative Receiver	Figure	NAC Category	NAC Level	Existing	Predicted 2050	Change (+/-)	Noise Impact (Yes/No)
R-1540	A-11	B-Residential	66	70	71	1	Yes
R-1541	A-11	B-Residential	66	70	72	2	Yes
R-1542	A-11	B-Residential	66	70	72	2	Yes
R-1543	A-11	B-Residential	66	70	70	0	Yes
R-1544	A-11	B-Residential	66	70	71	1	Yes
R-1545	A-11	B-Residential	66	71	72	1	Yes
R-1546	A-11	B-Residential	66	71	72	1	Yes
R-1547	A-11	B-Residential	66	70	71	1	Yes
R-1548	A-11	B-Residential	66	71	72	1	Yes
R-1549	A-11	B-Residential	66	72	73	1	Yes
R-1550	A-11	B-Residential	66	71	73	2	Yes
R-1551	A-11	B-Residential	66	70	71	1	Yes
R-1552	A-11	B-Residential	66	71	72	1	Yes
R-1553	A-11	B-Residential	66	72	72	0	Yes
R-1554	A-11	B-Residential	66	72	72	0	Yes
R-1555	A-11	B-Residential	66	70	67	-3	Yes
R-1556	A-11	B-Residential	66	70	71	1	Yes
R-1557	A-11	B-Residential	66	70	72	2	Yes
R-1558	A-11	B-Residential	66	70	74	4	Yes
R-1559	A-11	B-Residential	66	70	66	-4	Yes
R-1560	A-11	B-Residential	66	70	70	0	Yes
R-1561	A-11	B-Residential	66	70	72	2	Yes
R-1562	A-11	B-Residential	66	70	74	4	Yes
R-1563	A-11	B-Residential	66	70	67	-3	Yes
R-1564	A-11	B-Residential	66	70	70	0	Yes
R-1565	A-11	B-Residential	66	70	71	1	Yes
R-1566	A-11	B-Residential	66	70	73	3	Yes
R-1567	A-11	B-Residential	66	70	67	-3	Yes
R-1568	A-11	B-Residential	66	70	70	0	Yes
R-1569	A-11	B-Residential	66	70	71	1	Yes
R-1570	A-11	B-Residential	66	70	72	2	Yes
R-1571	A-11	B-Residential	66	70	67	-3	Yes
R-1572	A-11	B-Residential	66	70	69	-1	Yes
R-1573	A-11	B-Residential	66	70	71	1	Yes
R-1574	A-11	B-Residential	66	70	72	2	Yes
R-1575	A-11	B-Residential	66	70	67	-3	Yes
R-1576	A-11	B-Residential	66	70	69	-1	Yes
R-1577	A-11	B-Residential	66	70	70	0	Yes
R-1578	A-11	B-Residential	66	70	71	1	Yes

Traffic Noise Analysis Report Addendum – Preferred Alternative

Table 2. Segment A Traffic Noise Levels dB(A) Leq

Segment A Representative Receiver	Figure	NAC Category	NAC Level	Existing	Predicted 2050	Change (+/-)	Noise Impact (Yes/No)
R-1579	A-11	B-Residential	66	70	67	-3	Yes
R-1580	A-11	B-Residential	66	70	69	-1	Yes
R-1581	A-11	B-Residential	66	70	70	0	Yes
R-1582	A-11	B-Residential	66	70	71	1	Yes
R-1583	A-11	B-Residential	66	70	68	-2	Yes
R-1584	A-11	B-Residential	66	70	70	0	Yes
R-1585	A-11	B-Residential	66	70	71	1	Yes
R-1586	A-11	B-Residential	66	70	71	1	Yes
R-1587	A-11	B-Residential	66	70	69	-1	Yes
R-1588	A-11	B-Residential	66	71	71	0	Yes
R-1589	A-11	B-Residential	66	71	71	0	Yes
R-1590	A-11	B-Residential	66	71	72	1	Yes
R-1591	A-11	B-Residential	66	70	71	1	Yes
R-1592	A-11	B-Residential	66	73	72	-1	Yes
R-1593	A-11	B-Residential	66	73	72	-1	Yes
R-1594	A-11	B-Residential	66	73	72	-1	Yes
R-1595	A-11	B-Residential	66	70	66	-4	Yes
R-1596	A-11	B-Residential	66	70	69	-1	Yes
R-1597	A-11	B-Residential	66	70	72	2	Yes
R-1598	A-11	B-Residential	66	70	73	3	Yes
R-1599	A-11	B-Residential	66	70	66	-4	Yes
R-1600	A-11	B-Residential	66	70	69	-1	Yes
R-1601	A-11	B-Residential	66	70	71	1	Yes
R-1602	A-11	B-Residential	66	70	73	3	Yes
R-1603	A-11	B-Residential	66	70	66	-4	Yes
R-1604	A-11	B-Residential	66	70	69	-1	Yes
R-1605	A-11	B-Residential	66	70	71	1	Yes
R-1606	A-11	B-Residential	66	70	73	3	Yes
R-1607	A-11	B-Residential	66	70	65	-5	No
R-1608	A-11	B-Residential	66	70	69	-1	Yes
R-1609	A-11	B-Residential	66	70	71	1	Yes
R-1610	A-11	B-Residential	66	70	73	3	Yes
R-1611	A-11	B-Residential	66	70	65	-5	No
R-1612	A-11	B-Residential	66	70	69	-1	Yes
R-1613	A-11	B-Residential	66	70	70	0	Yes
R-1614	A-11	B-Residential	66	70	72	2	Yes
R-1615	A-11	B-Residential	66	70	66	-4	Yes
R-1616	A-11	B-Residential	66	70	68	-2	Yes
R-1617	A-11	B-Residential	66	70	70	0	Yes

Traffic Noise Analysis Report Addendum – Preferred Alternative

Table 2. Segment A Traffic Noise Levels dB(A) Leq

Segment A Representative Receiver	Figure	NAC Category	NAC Level	Existing	Predicted 2050	Change (+/-)	Noise Impact (Yes/No)
R-1618	A-11	B-Residential	66	70	70	0	Yes
R-1619	A-11	B-Residential	66	70	68	-2	Yes
R-1620	A-11	B-Residential	66	71	70	-1	Yes
R-1621	A-11	B-Residential	66	72	71	-1	Yes
R-1622	A-11	B-Residential	66	72	71	-1	Yes
R-1623	A-11	B-Residential	66	70	65	-5	No
R-1624	A-11	B-Residential	66	70	68	-2	Yes
R-1625	A-11	B-Residential	66	70	70	0	Yes
R-1626	A-11	B-Residential	66	70	72	2	Yes
R-1627	A-11	B-Residential	66	70	65	-5	No
R-1628	A-11	B-Residential	66	70	68	-2	Yes
R-1629	A-11	B-Residential	66	70	70	0	Yes
R-1630	A-11	B-Residential	66	70	71	1	Yes
R-1631	A-11	B-Residential	66	70	66	-4	Yes
R-1632	A-11	B-Residential	66	70	68	-2	Yes
R-1633	A-11	B-Residential	66	70	69	-1	Yes
R-1634	A-11	B-Residential	66	70	70	0	Yes
R-1635	A-11	B-Residential	66	70	67	-3	Yes
R-1636	A-11	B-Residential	66	72	70	-2	Yes
R-1637	A-11	B-Residential	66	72	70	-2	Yes
R-1638	A-11	B-Residential	66	72	71	-1	Yes
R-1639	A-11	B-Residential	66	70	65	-5	No
R-1640	A-11	B-Residential	66	70	68	-2	Yes
R-1641	A-11	B-Residential	66	70	70	0	Yes
R-1642	A-11	B-Residential	66	70	71	1	Yes
R-1643	A-11	B-Residential	66	70	65	-5	No
R-1644	A-11	B-Residential	66	70	68	-2	Yes
R-1645	A-11	B-Residential	66	70	69	-1	Yes
R-1646	A-11	B-Residential	66	70	70	0	Yes
R-1647	A-11	B-Residential	66	70	65	-5	No
R-1648	A-11	B-Residential	66	70	68	-2	Yes
R-1649	A-11	B-Residential	66	70	69	-1	Yes
R-1650	A-11	B-Residential	66	70	70	0	Yes
R-1651	A-11	B-Residential	66	70	67	-3	Yes
R-1652	A-11	B-Residential	66	72	70	-2	Yes
R-1653	A-11	B-Residential	66	72	70	-2	Yes
R-1654	A-11	B-Residential	66	72	70	-2	Yes
R-1655	A-11	B-Residential	66	70	64	-6	No
R-1656	A-11	B-Residential	66	70	67	-3	Yes

Traffic Noise Analysis Report Addendum – Preferred Alternative

Table 2. Segment A Traffic Noise Levels dB(A) Leq

Segment A Representative Receiver	Figure	NAC Category	NAC Level	Existing	Predicted 2050	Change (+/-)	Noise Impact (Yes/No)
R-1657	A-11	B-Residential	66	70	69	-1	Yes
R-1658	A-11	B-Residential	66	70	70	0	Yes
R-1659	A-11	B-Residential	66	70	64	-6	No
R-1670	A-11	B-Residential	66	70	67	-3	Yes
R-1671	A-11	B-Residential	66	70	69	-1	Yes
R-1672	A-11	B-Residential	66	70	70	0	Yes
R-1673	A-11	B-Residential	66	70	65	-5	No
R-1674	A-11	B-Residential	66	70	68	-2	Yes
R-1675	A-11	B-Residential	66	70	69	-1	Yes
R-1676	A-11	B-Residential	66	70	69	-1	Yes
R-1677	A-11	B-Residential	66	70	67	-3	Yes
R-1678	A-11	B-Residential	66	72	69	-3	Yes
R-1679	A-11	B-Residential	66	72	70	-2	Yes
R-1680	A-11	B-Residential	66	72	70	-2	Yes
R-1681	A-11	B-Residential	66	70	65	-5	No
R-1682	A-11	B-Residential	66	70	67	-3	Yes
R-1683	A-11	B-Residential	66	70	68	-2	Yes
R-1684	A-11	B-Residential	66	70	69	-1	Yes
R-1685	A-11	B-Residential	66	70	67	-3	Yes
R-1686	A-11	B-Residential	66	72	69	-3	Yes
R-1687	A-11	B-Residential	66	72	70	-2	Yes
R-1688	A-11	B-Residential	66	72	70	-2	Yes
R-1689	A-11	B-Residential	66	70	65	-5	No
R-1690	A-11	B-Residential	66	70	67	-3	Yes
R-1691	A-11	B-Residential	66	70	68	-2	Yes
R-1692	A-11	B-Residential	66	70	69	-1	Yes
R-1693	A-11	B-Residential	66	70	67	-3	Yes
R-1694	A-11	B-Residential	66	72	69	-3	Yes
R-1695	A-11	B-Residential	66	72	70	-2	Yes
R-1696	A-11	B-Residential	66	72	70	-2	Yes
R-1697	A-11	B-Residential	66	70	65	-5	No
R-1698	A-11	B-Residential	66	70	67	-3	Yes
R-1699	A-11	B-Residential	66	70	68	-2	Yes
R-1700	A-11	B-Residential	66	70	69	-1	Yes
R-1701	A-11	B-Residential	66	70	67	-3	Yes
R-1702	A-11	B-Residential	66	72	69	-3	Yes
R-1703	A-11	B-Residential	66	72	70	-2	Yes
R-1704	A-11	B-Residential	66	72	70	-2	Yes
R-1705	A-11	B-Residential	66	70	65	-5	No

Traffic Noise Analysis Report Addendum – Preferred Alternative

Table 2. Segment A Traffic Noise Levels dB(A) Leq

Segment A Representative Receiver	Figure	NAC Category	NAC Level	Existing	Predicted 2050	Change (+/-)	Noise Impact (Yes/No)
R-1706	A-11	B-Residential	66	70	67	-3	Yes
R-1707	A-11	B-Residential	66	70	68	-2	Yes
R-1708	A-11	B-Residential	66	70	68	-2	Yes
R-1709	A-11	B-Residential	66	70	67	-3	Yes
R-1710	A-11	B-Residential	66	72	69	-3	Yes
R-1711	A-11	B-Residential	66	72	70	-2	Yes
R-1712	A-11	B-Residential	66	72	70	-2	Yes
R-1713	A-11	B-Residential	66	70	64	-6	No
R-1714	A-11	B-Residential	66	70	66	-4	Yes
R-1715	A-11	B-Residential	66	70	68	-2	Yes
R-1716	A-11	B-Residential	66	70	69	-1	Yes
R-1717	A-11	B-Residential	66	70	64	-6	No
R-1718	A-11	B-Residential	66	70	66	-4	Yes
R-1719	A-11	B-Residential	66	70	68	-2	Yes
R-1720	A-11	B-Residential	66	70	69	-1	Yes
R-1721	A-11	B-Residential	66	70	64	-6	No
R-1722	A-11	B-Residential	66	70	66	-4	Yes
R-1723	A-11	B-Residential	66	70	67	-3	Yes
R-1724	A-11	B-Residential	66	70	69	-1	Yes
R-1725	A-11	B-Residential	66	70	63	-7	No
R-1726	A-11	B-Residential	66	70	66	-4	Yes
R-1727	A-11	B-Residential	66	70	67	-3	Yes
R-1728	A-11	B-Residential	66	70	68	-2	Yes
R-1729	A-11	B-Residential	66	70	63	-7	No
R-1730	A-11	B-Residential	66	70	66	-4	Yes
R-1731	A-11	B-Residential	66	70	67	-3	Yes
R-1732	A-11	B-Residential	66	70	68	-2	Yes
R-1733	A-11	B-Residential	66	70	63	-7	No
R-1734	A-11	B-Residential	66	70	66	-4	Yes
R-1735	A-11	B-Residential	66	70	67	-3	Yes
R-1736	A-11	B-Residential	66	70	68	-2	Yes
R-1737	A-11	B-Residential	66	70	63	-7	No
R-1738	A-11	B-Residential	66	70	66	-4	Yes
R-1739	A-11	B-Residential	66	70	67	-3	Yes
R-1740	A-11	B-Residential	66	70	68	-2	Yes
R-1741	A-11	B-Residential	66	70	63	-7	No
R-1742	A-11	B-Residential	66	70	65	-5	No
R-1743	A-11	B-Residential	66	70	66	-4	Yes
R-1744	A-11	B-Residential	66	70	67	-3	Yes

Traffic Noise Analysis Report Addendum – Preferred Alternative

Table 2. Segment A Traffic Noise Levels dB(A) Leq

Segment A Representative Receiver	Figure	NAC Category	NAC Level	Existing	Predicted 2050	Change (+/-)	Noise Impact (Yes/No)
R-1745	A-11	B-Residential	66	70	63	-7	No
R-1746	A-11	B-Residential	66	70	65	-5	No
R-1747	A-11	B-Residential	66	70	66	-4	Yes
R-1748	A-11	B-Residential	66	70	67	-3	Yes
R-1749	A-11	B-Residential	66	70	62	-8	No
R-1750	A-11	B-Residential	66	70	65	-5	No
R-1751	A-11	B-Residential	66	70	66	-4	Yes
R-1752	A-11	B-Residential	66	70	67	-3	Yes
R-1753	A-11	B-Residential	66	70	62	-8	No
R-1754	A-11	B-Residential	66	70	65	-5	No
R-1755	A-11	B-Residential	66	70	66	-4	Yes
R-1756	A-11	B-Residential	66	70	67	-3	Yes
R-1757	A-11	B-Residential	66	70	62	-8	No
R-1758	A-11	B-Residential	66	70	65	-5	No
R-1759	A-11	B-Residential	66	70	66	-4	Yes
R-1760	A-11	B-Residential	66	70	66	-4	Yes
R-1761	A-11	B-Residential	66	70	64	-6	No
R-1762	A-11	B-Residential	66	70	66	-4	Yes
R-1763	A-11	B-Residential	66	70	67	-3	Yes
R-1764	A-11	B-Residential	66	70	68	-2	Yes
R-1765	A-11	B-Residential	66	70	63	-7	No
R-1766	A-11	B-Residential	66	70	66	-4	Yes
R-1767	A-11	B-Residential	66	70	66	-4	Yes
R-1768	A-11	B-Residential	66	70	67	-3	Yes
R-1769	A-11	B-Residential	66	70	65	-5	No
R-1770	A-11	B-Residential	66	70	67	-3	Yes
R-1771	A-11	B-Residential	66	70	68	-2	Yes
R-1772	A-11	B-Residential	66	70	68	-2	Yes
R-1773	A-11	B-Residential	66	70	62	-8	No
R-1774	A-11	B-Residential	66	70	65	-5	No
R-1775	A-11	B-Residential	66	70	66	-4	Yes
R-1776	A-11	B-Residential	66	70	67	-3	Yes
R-1777	A-11	B-Residential	66	70	63	-7	No
R-1778	A-11	B-Residential	66	70	66	-4	Yes
R-1779	A-11	B-Residential	66	70	67	-3	Yes
R-1780	A-11	B-Residential	66	70	67	-3	Yes
R-1781	A-11	B-Residential	66	70	66	-4	Yes
R-1782	A-11	B-Residential	66	70	68	-2	Yes
R-1783	A-11	B-Residential	66	71	68	-3	Yes

Traffic Noise Analysis Report Addendum – Preferred Alternative

Table 2. Segment A Traffic Noise Levels dB(A) Leq

Segment A Representative Receiver	Figure	NAC Category	NAC Level	Existing	Predicted 2050	Change (+/-)	Noise Impact (Yes/No)
R-1784	A-11	B-Residential	66	71	69	-2	Yes
R-1785	A-11	B-Residential	66	70	62	-8	No
R-1786	A-11	B-Residential	66	70	65	-5	No
R-1787	A-11	B-Residential	66	70	66	-4	Yes
R-1788	A-11	B-Residential	66	70	66	-4	Yes
R-1789	A-11	B-Residential	66	70	63	-7	No
R-1790	A-11	B-Residential	66	70	66	-4	Yes
R-1791	A-11	B-Residential	66	70	66	-4	Yes
R-1792	A-11	B-Residential	66	70	67	-3	Yes
R-1793	A-11	B-Residential	66	70	65	-5	No
R-1794	A-11	B-Residential	66	70	67	-3	Yes
R-1795	A-11	B-Residential	66	70	68	-2	Yes
R-1796	A-11	B-Residential	66	70	68	-2	Yes
R-1797	A-11	B-Residential	66	70	67	-3	Yes
R-1798	A-11	B-Residential	66	72	69	-3	Yes
R-1799	A-11	B-Residential	66	72	70	-2	Yes
R-1800	A-11	B-Residential	66	72	69	-3	Yes
R-1801	A-11	B-Residential	66	70	62	-8	No
R-1802	A-11	B-Residential	66	70	65	-5	No
R-1803	A-11	B-Residential	66	70	66	-4	Yes
R-1804	A-11	B-Residential	66	70	66	-4	Yes
R-1805	A-11	B-Residential	66	70	62	-8	No
R-1806	A-11	B-Residential	66	70	65	-5	No
R-1807	A-11	B-Residential	66	70	66	-4	Yes
R-1808	A-11	B-Residential	66	70	66	-4	Yes
R-1809	A-11	B-Residential	66	70	64	-6	No
R-1810	A-11	B-Residential	66	70	66	-4	Yes
R-1811	A-11	B-Residential	66	70	67	-3	Yes
R-1812	A-11	B-Residential	66	70	68	-2	Yes
R-1813	A-11	B-Residential	66	70	66	-4	Yes
R-1814	A-11	B-Residential	66	71	68	-3	Yes
R-1815	A-11	B-Residential	66	71	68	-3	Yes
R-1816	A-11	B-Residential	66	71	69	-2	Yes
R-1817	A-11	B-Residential	66	70	62	-8	No
R-1818	A-11	B-Residential	66	70	65	-5	No
R-1819	A-11	B-Residential	66	70	65	-5	No
R-1820	A-11	B-Residential	66	70	66	-4	Yes
R-1821	A-11	B-Residential	66	70	62	-8	No
R-1822	A-11	B-Residential	66	70	65	-5	No

Traffic Noise Analysis Report Addendum – Preferred Alternative

Table 2. Segment A Traffic Noise Levels dB(A) Leq

Segment A Representative Receiver	Figure	NAC Category	NAC Level	Existing	Predicted 2050	Change (+/-)	Noise Impact (Yes/No)
R-1823	A-11	B-Residential	66	70	65	-5	No
R-1824	A-11	B-Residential	66	70	66	-4	Yes
R-1825	A-11	B-Residential	66	70	63	-7	No
R-1826	A-11	B-Residential	66	70	66	-4	Yes
R-1827	A-11	B-Residential	66	70	66	-4	Yes
R-1828	A-11	B-Residential	66	70	67	-3	Yes
R-1829	A-11	B-Residential	66	70	64	-6	No
R-1830	A-11	B-Residential	66	70	67	-3	Yes
R-1831	A-11	B-Residential	66	70	67	-3	Yes
R-1832	A-11	B-Residential	66	70	68	-2	Yes
R-1833	A-11	B-Residential	66	70	61	-9	No
R-1834	A-11	B-Residential	66	70	64	-6	No
R-1835	A-11	B-Residential	66	70	65	-5	No
R-1836	A-11	B-Residential	66	70	66	-4	Yes
R-1837	A-11	B-Residential	66	70	62	-8	No
R-1838	A-11	B-Residential	66	70	65	-5	No
R-1839	A-11	B-Residential	66	70	66	-4	Yes
R-1840	A-11	B-Residential	66	70	66	-4	Yes
R-1841	A-11	B-Residential	66	70	64	-6	No
R-1842	A-11	B-Residential	66	70	66	-4	Yes
R-1843	A-11	B-Residential	66	70	67	-3	Yes
R-1844	A-11	B-Residential	66	70	67	-3	Yes
R-1845	A-11	B-Residential	66	70	62	-8	No
R-1846	A-11	B-Residential	66	70	65	-5	No
R-1847	A-11	B-Residential	66	70	65	-5	No
R-1848	A-11	B-Residential	66	70	66	-4	Yes
R-1849	A-11	B-Residential	66	70	63	-7	No
R-1850	A-11	B-Residential	66	70	65	-5	No
R-1851	A-11	B-Residential	66	70	66	-4	Yes
R-1852	A-11	B-Residential	66	70	67	-3	Yes
R-1853	A-11	B-Residential	66	70	61	-9	No
R-1854	A-11	B-Residential	66	70	64	-6	No
R-1855	A-11	B-Residential	66	70	65	-5	No
R-1856	A-11	B-Residential	66	70	66	-4	Yes
R-1857	A-11	B-Residential	66	70	62	-8	No
R-1858	A-11	B-Residential	66	70	65	-5	No
R-1859	A-11	B-Residential	66	70	66	-4	Yes
R-1860	A-11	B-Residential	66	70	66	-4	Yes
R-1861	A-11	B-Residential	66	70	61	-9	No

Traffic Noise Analysis Report Addendum – Preferred Alternative

Table 2. Segment A Traffic Noise Levels dB(A) Leq

Segment A Representative Receiver	Figure	NAC Category	NAC Level	Existing	Predicted 2050	Change (+/-)	Noise Impact (Yes/No)
R-1862	A-11	B-Residential	66	70	64	-6	No
R-1863	A-11	B-Residential	66	70	65	-5	No
R-1864	A-11	B-Residential	66	70	65	-5	No
R-1865	A-11	B-Residential	66	70	61	-9	No
R-1866	A-11	B-Residential	66	70	64	-6	No
R-1867	A-11	B-Residential	66	70	65	-5	No
R-1868	A-11	B-Residential	66	70	66	-4	Yes
R-1869	A-11	B-Residential	66	70	61	-9	No
R-1870	A-11	B-Residential	66	70	64	-6	No
R-1871	A-11	B-Residential	66	70	65	-5	No
R-1872	A-11	B-Residential	66	70	65	-5	No
R-1873	A-11	B-Residential	66	70	61	-9	No
R-1874	A-11	B-Residential	66	70	64	-6	No
R-1875	A-11	B-Residential	66	70	65	-5	No
R-1876	A-11	B-Residential	66	70	65	-5	No
R-1877	A-11	B-Residential	66	70	61	-9	No
R-1878	A-11	B-Residential	66	70	64	-6	No
R-1879	A-11	B-Residential	66	70	65	-5	No
R-1880	A-11	B-Residential	66	70	65	-5	No
R-1881	A-11	B-Residential	66	70	61	-9	No
R-1882	A-11	B-Residential	66	70	64	-6	No
R-1883	A-11	B-Residential	66	70	65	-5	No
R-1884	A-11	B-Residential	66	70	65	-5	No
R-1885	A-11	B-Residential	66	70	61	-9	No
R-1886	A-11	B-Residential	66	70	64	-6	No
R-1887	A-11	B-Residential	66	70	65	-5	No
R-1888	A-11	B-Residential	66	70	66	-4	Yes
R-1889	A-11	B-Residential	66	70	61	-9	No
R-1890	A-11	B-Residential	66	70	64	-6	No
R-1891	A-11	B-Residential	66	70	65	-5	No
R-1892	A-11	B-Residential	66	70	65	-5	No
R-1893	A-11	B-Residential	66	70	64	-6	No
R-1894	A-11	B-Residential	66	70	67	-3	Yes
R-1895	A-11	B-Residential	66	70	67	-3	Yes
R-1896	A-11	B-Residential	66	70	68	-2	Yes
R-1897	A-11	B-Residential	66	70	66	-4	Yes
R-1898	A-11	B-Residential	66	71	68	-3	Yes
R-1899	A-11	B-Residential	66	72	69	-3	Yes
R-1900	A-11	B-Residential	66	72	69	-3	Yes

Traffic Noise Analysis Report Addendum – Preferred Alternative

Table 2. Segment A Traffic Noise Levels dB(A) Leq

Segment A Representative Receiver	Figure	NAC Category	NAC Level	Existing	Predicted 2050	Change (+/-)	Noise Impact (Yes/No)
R-1901	A-11	B-Residential	66	70	60	-10	No
R-1902	A-11	B-Residential	66	70	64	-6	No
R-1903	A-11	B-Residential	66	70	64	-6	No
R-1904	A-11	B-Residential	66	70	65	-5	No
R-1905	A-11	B-Residential	66	70	60	-10	No
R-1906	A-11	B-Residential	66	70	64	-6	No
R-1907	A-11	B-Residential	66	70	64	-6	No
R-1908	A-11	B-Residential	66	70	65	-5	No
R-1909	A-11	B-Residential	66	70	60	-10	No
R-1910	A-11	B-Residential	66	70	64	-6	No
R-1911	A-11	B-Residential	66	70	64	-6	No
R-1912	A-11	B-Residential	66	70	65	-5	No
R-1913	A-11	B-Residential	66	70	61	-9	No
R-1914	A-11	B-Residential	66	70	64	-6	No
R-1915	A-11	B-Residential	66	70	64	-6	No
R-1916	A-11	B-Residential	66	70	65	-5	No
R-1917	A-11	B-Residential	66	70	60	-10	No
R-1918	A-11	B-Residential	66	70	64	-6	No
R-1919	A-11	B-Residential	66	70	64	-6	No
R-1920	A-11	B-Residential	66	70	65	-5	No
R-1921	A-11	B-Residential	66	70	64	-6	No
R-1922	A-11	B-Residential	66	70	66	-4	Yes
R-1923	A-11	B-Residential	66	70	67	-3	Yes
R-1924	A-11	B-Residential	66	70	67	-3	Yes
R-1925	A-11	B-Residential	66	70	66	-4	Yes
R-1926	A-11	B-Residential	66	71	68	-3	Yes
R-1927	A-11	B-Residential	66	71	68	-3	Yes
R-1928	A-11	B-Residential	66	71	68	-3	Yes
R-1929	A-11	B-Residential	66	70	64	-6	No
R-1930	A-11	B-Residential	66	70	66	-4	Yes
R-1931	A-11	B-Residential	66	70	67	-3	Yes
R-1932	A-11	B-Residential	66	70	67	-3	Yes
R-1933	A-11	B-Residential	66	70	65	-5	No
R-1934	A-11	B-Residential	66	71	68	-3	Yes
R-1935	A-11	B-Residential	66	71	68	-3	Yes
R-1936	A-11	B-Residential	66	71	68	-3	Yes
R-1937	A-11	B-Residential	66	70	60	-10	No
R-1938	A-11	B-Residential	66	70	63	-7	No
R-1939	A-11	B-Residential	66	70	64	-6	No

Traffic Noise Analysis Report Addendum – Preferred Alternative

Table 2. Segment A Traffic Noise Levels dB(A) Leq

Segment A Representative Receiver	Figure	NAC Category	NAC Level	Existing	Predicted 2050	Change (+/-)	Noise Impact (Yes/No)
R-1940	A-11	B-Residential	66	70	64	-6	No
R-1941	A-11	B-Residential	66	70	60	-10	No
R-1942	A-11	B-Residential	66	70	63	-7	No
R-1943	A-11	B-Residential	66	70	64	-6	No
R-1944	A-11	B-Residential	66	70	64	-6	No
R-1945	A-11	B-Residential	66	70	60	-10	No
R-1946	A-11	B-Residential	66	70	63	-7	No
R-1947	A-11	B-Residential	66	70	64	-6	No
R-1948	A-11	B-Residential	66	70	64	-6	No
R-1949	A-11	B-Residential	66	70	60	-10	No
R-1950	A-11	B-Residential	66	70	63	-7	No
R-1951	A-11	B-Residential	66	70	64	-6	No
R-1952	A-11	B-Residential	66	70	64	-6	No
R-1953	A-11	B-Residential	66	70	62	-8	No
R-1954	A-11	B-Residential	66	70	65	-5	No
R-1955	A-11	B-Residential	66	70	66	-4	Yes
R-1956	A-11	B-Residential	66	70	67	-3	Yes
R-1957	A-11	B-Residential	66	70	61	-9	No
R-1958	A-11	B-Residential	66	70	64	-6	No
R-1959	A-11	B-Residential	66	70	65	-5	No
R-1960	A-11	B-Residential	66	70	66	-4	Yes
R-1961	A-11	B-Residential	66	70	61	-9	No
R-1962	A-11	B-Residential	66	70	64	-6	No
R-1963	A-11	B-Residential	66	70	65	-5	No
R-1964	A-11	B-Residential	66	70	65	-5	No
R-1965	A-11	B-Residential	66	70	60	-10	No
R-1966	A-11	B-Residential	66	70	63	-7	No
R-1967	A-11	B-Residential	66	70	64	-6	No
R-1968	A-11	B-Residential	66	70	65	-5	No
R-1969	A-11	B-Residential	66	70	59	-11	No
R-1970	A-11	B-Residential	66	70	62	-8	No
R-1971	A-11	B-Residential	66	70	63	-7	No
R-1972	A-11	B-Residential	66	70	63	-7	No
R-1973	A-11	B-Residential	66	70	59	-11	No
R-1974	A-11	B-Residential	66	70	62	-8	No
R-1975	A-11	B-Residential	66	70	63	-7	No
R-1976	A-11	B-Residential	66	70	63	-7	No
R-1977	A-11	B-Residential	66	70	59	-11	No
R-1978	A-11	B-Residential	66	70	62	-8	No

Traffic Noise Analysis Report Addendum – Preferred Alternative

Table 2. Segment A Traffic Noise Levels dB(A) Leq

Segment A Representative Receiver	Figure	NAC Category	NAC Level	Existing	Predicted 2050	Change (+/-)	Noise Impact (Yes/No)
R-1979	A-11	B-Residential	66	70	63	-7	No
R-1980	A-11	B-Residential	66	70	64	-6	No
R-1981	A-11	B-Residential	66	70	59	-11	No
R-1982	A-11	B-Residential	66	70	63	-7	No
R-1983	A-11	B-Residential	66	70	64	-6	No
R-1984	A-11	B-Residential	66	70	64	-6	No
R-1985	A-11	B-Residential	66	70	58	-12	No
R-1986	A-11	B-Residential	66	70	62	-8	No
R-1987	A-11	B-Residential	66	70	63	-7	No
R-1988	A-11	B-Residential	66	70	63	-7	No
R-1989	A-11	B-Residential	66	70	58	-12	No
R-1990	A-11	B-Residential	66	70	62	-8	No
R-1991	A-11	B-Residential	66	70	63	-7	No
R-1992	A-11	B-Residential	66	70	63	-7	No
R-1993	A-11	B-Residential	66	70	59	-11	No
R-1994	A-11	B-Residential	66	70	62	-8	No
R-1995	A-11	B-Residential	66	70	63	-7	No
R-1996	A-11	B-Residential	66	70	64	-6	No
R-1997	A-11	B-Residential	66	70	59	-11	No
R-1998	A-11	B-Residential	66	70	63	-7	No
R-1999	A-11	B-Residential	66	70	64	-6	No
R-2000	A-11	B-Residential	66	70	60	-10	No
R-2001	A-11	B-Residential	66	70	63	-7	No
R-2002	A-11	B-Residential	66	70	64	-6	No
R-2003	A-11	B-Residential	66	70	65	-5	No
R-2004	A-11	B-Residential	66	70	61	-9	No
R-2005	A-11	B-Residential	66	70	64	-6	No
R-2006	A-11	B-Residential	66	70	65	-5	No
R-2007	A-11	B-Residential	66	70	66	-4	Yes
R-2008	A-11	B-Residential	66	70	62	-8	No
R-2009	A-11	B-Residential	66	70	65	-5	No
R-2010	A-11	B-Residential	66	70	66	-4	Yes
R-2011	A-11	B-Residential	66	70	66	-4	Yes
R-2012	A-11	B-Residential	66	70	62	-8	No
R-2013	A-11	B-Residential	66	70	65	-5	No
R-2014	A-11	B-Residential	66	70	67	-3	Yes
R-2015	A-11	B-Residential	66	70	67	-3	Yes
R-2016	A-11	B-Residential	66	70	58	-12	No
R-2017	A-11	B-Residential	66	70	62	-8	No

Traffic Noise Analysis Report Addendum – Preferred Alternative

Table 2. Segment A Traffic Noise Levels dB(A) Leq

Segment A Representative Receiver	Figure	NAC Category	NAC Level	Existing	Predicted 2050	Change (+/-)	Noise Impact (Yes/No)
R-2018	A-11	B-Residential	66	70	63	-7	No
R-2019	A-11	B-Residential	66	70	63	-7	No
R-2020	A-11	B-Residential	66	70	58	-12	No
R-2021	A-11	B-Residential	66	70	62	-8	No
R-2022	A-11	B-Residential	66	70	63	-7	No
R-2023	A-11	B-Residential	66	70	63	-7	No
R-2024	A-11	B-Residential	66	70	58	-12	No
R-2025	A-11	B-Residential	66	70	62	-8	No
R-2026	A-11	B-Residential	66	70	63	-7	No
R-2027	A-11	B-Residential	66	70	63	-7	No
R-2028	A-11	B-Residential	66	70	59	-11	No
R-2029	A-11	B-Residential	66	70	63	-7	No
R-2030	A-11	B-Residential	66	70	64	-6	No
R-2031	A-11	B-Residential	66	70	64	-6	No
R-2032	A-11	B-Residential	66	70	58	-12	No
R-2033	A-11	B-Residential	66	70	62	-8	No
R-2034	A-11	B-Residential	66	70	63	-7	No
R-2035	A-11	B-Residential	66	70	63	-7	No
R-2036	A-11	B-Residential	66	70	58	-12	No
R-2037	A-11	B-Residential	66	70	62	-8	No
R-2038	A-11	B-Residential	66	70	63	-7	No
R-2039	A-11	B-Residential	66	70	63	-7	No
R-2040	A-11	B-Residential	66	70	58	-12	No
R-2041	A-11	B-Residential	66	70	62	-8	No
R-2042	A-11	B-Residential	66	70	63	-7	No
R-2043	A-11	B-Residential	66	70	63	-7	No
R-2044	A-11	B-Residential	66	70	59	-11	No
R-2045	A-11	B-Residential	66	70	62	-8	No
R-2046	A-11	B-Residential	66	70	63	-7	No
R-2047	A-11	B-Residential	66	70	64	-6	No
R-2048	A-10	B-Residential	66	70	62	-8	No
R-2049	A-10	B-Residential	66	70	65	-5	No
R-2050	A-10	B-Residential	66	70	66	-4	Yes
R-2051	A-10	B-Residential	66	70	67	-3	Yes
R-2052	A-10	B-Residential	66	70	64	-6	No
R-2053	A-10	B-Residential	66	70	67	-3	Yes
R-2054	A-10	B-Residential	66	71	68	-3	Yes
R-2055	A-10	B-Residential	66	71	68	-3	Yes
R-2056	A-10	B-Residential	66	70	61	-9	No

Traffic Noise Analysis Report Addendum – Preferred Alternative

Table 2. Segment A Traffic Noise Levels dB(A) Leq

Segment A Representative Receiver	Figure	NAC Category	NAC Level	Existing	Predicted 2050	Change (+/-)	Noise Impact (Yes/No)
R-2057	A-10	B-Residential	66	70	65	-5	No
R-2058	A-10	B-Residential	66	70	66	-4	Yes
R-2059	A-10	B-Residential	66	70	67	-3	Yes
R-2060	A-10	B-Residential	66	70	64	-6	No
R-2061	A-10	B-Residential	66	70	67	-3	Yes
R-2062	A-10	B-Residential	66	70	68	-2	Yes
R-2063	A-10	B-Residential	66	70	68	-2	Yes
R-2064	A-10	B-Residential	66	70	61	-9	No
R-2065	A-10	B-Residential	66	70	65	-5	No
R-2066	A-10	B-Residential	66	70	66	-4	Yes
R-2067	A-10	B-Residential	66	70	67	-3	Yes
R-2068	A-10	B-Residential	66	70	64	-6	No
R-2069	A-10	B-Residential	66	70	67	-3	Yes
R-2070	A-10	B-Residential	66	70	68	-2	Yes
R-2071	A-10	B-Residential	66	70	68	-2	Yes
R-2072	A-10	B-Residential	66	70	61	-9	No
R-2073	A-10	B-Residential	66	70	65	-5	No
R-2074	A-10	B-Residential	66	70	66	-4	Yes
R-2075	A-10	B-Residential	66	70	67	-3	Yes
R-2076	A-10	B-Residential	66	70	64	-6	No
R-2077	A-10	B-Residential	66	70	67	-3	Yes
R-2078	A-10	B-Residential	66	70	68	-2	Yes
R-2079	A-10	B-Residential	66	70	68	-2	Yes
R-2080	A-10	B-Residential	66	70	61	-9	No
R-2081	A-10	B-Residential	66	70	65	-5	No
R-2082	A-10	B-Residential	66	70	66	-4	Yes
R-2083	A-10	B-Residential	66	70	66	-4	Yes
R-2084	A-10	B-Residential	66	70	64	-6	No
R-2085	A-10	B-Residential	66	70	68	-2	Yes
R-2086	A-10	B-Residential	66	70	68	-2	Yes
R-2087	A-10	B-Residential	66	70	68	-2	Yes
R-2088	A-10	B-Residential	66	70	62	-8	No
R-2089	A-10	B-Residential	66	70	65	-5	No
R-2090	A-10	B-Residential	66	70	66	-4	Yes
R-2091	A-10	B-Residential	66	70	67	-3	Yes
R-2092	A-10	B-Residential	66	70	64	-6	No
R-2093	A-10	B-Residential	66	70	67	-3	Yes
R-2094	A-10	B-Residential	66	70	68	-2	Yes
R-2095	A-10	B-Residential	66	70	68	-2	Yes

Traffic Noise Analysis Report Addendum – Preferred Alternative

Table 2. Segment A Traffic Noise Levels dB(A) Leq

Segment A Representative Receiver	Figure	NAC Category	NAC Level	Existing	Predicted 2050	Change (+/-)	Noise Impact (Yes/No)
R-2096	A-10	B-Residential	66	70	61	-9	No
R-2097	A-10	B-Residential	66	70	65	-5	No
R-2098	A-10	B-Residential	66	70	66	-4	Yes
R-2099	A-10	B-Residential	66	70	66	-4	Yes
R-2100	A-10	B-Residential	66	70	64	-6	No
R-2101	A-10	B-Residential	66	70	67	-3	Yes
R-2102	A-10	B-Residential	66	70	68	-2	Yes
R-2103	A-10	B-Residential	66	70	68	-2	Yes
R-2104	A-10	B-Residential	66	70	61	-9	No
R-2105	A-10	B-Residential	66	70	64	-6	No
R-2106	A-10	B-Residential	66	70	66	-4	Yes
R-2107	A-10	B-Residential	66	70	66	-4	Yes
R-2108	A-10	B-Residential	66	70	65	-5	No
R-2109	A-10	B-Residential	66	70	67	-3	Yes
R-2110	A-10	B-Residential	66	70	68	-2	Yes
R-2111	A-10	B-Residential	66	70	68	-2	Yes
R-2112	A-10	B-Residential	66	70	61	-9	No
R-2113	A-10	B-Residential	66	70	64	-6	No
R-2114	A-10	B-Residential	66	70	66	-4	Yes
R-2115	A-10	B-Residential	66	70	66	-4	Yes
R-2116	A-10	B-Residential	66	70	64	-6	No
R-2117	A-10	B-Residential	66	70	67	-3	Yes
R-2118	A-10	B-Residential	66	70	68	-2	Yes
R-2119	A-10	B-Residential	66	70	68	-2	Yes
R-2120	A-10	B-Residential	66	70	61	-9	No
R-2121	A-10	B-Residential	66	70	64	-6	No
R-2122	A-10	B-Residential	66	70	66	-4	Yes
R-2123	A-10	B-Residential	66	70	66	-4	Yes
R-2124	A-10	B-Residential	66	70	64	-6	No
R-2125	A-10	B-Residential	66	70	67	-3	Yes
R-2126	A-10	B-Residential	66	70	68	-2	Yes
R-2127	A-10	B-Residential	66	70	68	-2	Yes
R-2128	A-10	B-Residential	66	70	61	-9	No
R-2129	A-10	B-Residential	66	70	64	-6	No
R-2130	A-10	B-Residential	66	70	66	-4	Yes
R-2131	A-10	B-Residential	66	70	66	-4	Yes
R-2132	A-10	B-Residential	66	70	65	-5	No
R-2133	A-10	B-Residential	66	70	67	-3	Yes
R-2134	A-10	B-Residential	66	70	68	-2	Yes

Traffic Noise Analysis Report Addendum – Preferred Alternative

Table 2. Segment A Traffic Noise Levels dB(A) Leq

Segment A Representative Receiver	Figure	NAC Category	NAC Level	Existing	Predicted 2050	Change (+/-)	Noise Impact (Yes/No)
R-2135	A-10	B-Residential	66	70	68	-2	Yes
R-2136	A-10	B-Residential	66	70	61	-9	No
R-2137	A-10	B-Residential	66	70	64	-6	No
R-2138	A-10	B-Residential	66	70	66	-4	Yes
R-2139	A-10	B-Residential	66	70	66	-4	Yes
R-2140	A-10	B-Residential	66	70	65	-5	No
R-2141	A-10	B-Residential	66	70	67	-3	Yes
R-2142	A-10	B-Residential	66	70	68	-2	Yes
R-2143	A-10	B-Residential	66	70	68	-2	Yes
R-2318	A-4	B-Residential	66	62	63	1	No
R-2319	A-4	B-Residential	66	63	70	7	Yes
R-2320	A-4	B-Residential	66	63	71	8	Yes
R-2321	A-4	B-Residential	66	64	72	8	Yes
R-2322	A-4	B-Residential	66	62	67	5	Yes
R-2323	A-4	B-Residential	66	63	71	8	Yes
R-2324	A-4	B-Residential	66	66	76	10	Yes
R-2325	A-4	B-Residential	66	63	71	8	Yes
R-2326	A-4	B-Residential	66	62	65	3	No
R-2327	A-4	B-Residential	66	65	73	8	Yes
R-2328	A-4	B-Residential	66	63	72	9	Yes
R-2329	A-4	B-Residential	66	64	72	8	Yes
R-2330	A-4	B-Residential	66	62	69	7	Yes
R-2331	A-4	B-Residential	66	62	64	2	No
R-2332	A-4	B-Residential	66	64	73	9	Yes
R-2333	A-4	B-Residential	66	62	65	3	No
R-2334	A-4	B-Residential	66	62	67	5	Yes
R-2335	A-4	B-Residential	66	62	67	5	Yes
R-2336	A-4	B-Residential	66	62	69	7	Yes
R-2337	A-4	B-Residential	66	63	71	8	Yes
R-2338	A-4	B-Residential	66	62	60	-2	No
R-2339	A-4	B-Residential	66	62	65	3	No
R-2340	A-4	B-Residential	66	62	63	1	No
R-2341	A-4	B-Residential	66	65	73	8	Yes
R-2342	A-4	B-Residential	66	63	70	7	Yes
R-2343	A-4	B-Residential	66	62	70	8	Yes
R-2344	A-4	B-Residential	66	62	68	6	Yes
R-2345	A-4	B-Residential	66	62	63	1	No
R-2346	A-4	B-Residential	66	64	72	8	Yes
R-2347	A-4	B-Residential	66	63	70	7	Yes

Traffic Noise Analysis Report Addendum – Preferred Alternative

Table 2. Segment A Traffic Noise Levels dB(A) Leq

Segment A Representative Receiver	Figure	NAC Category	NAC Level	Existing	Predicted 2050	Change (+/-)	Noise Impact (Yes/No)
R-2348	A-4	B-Residential	66	63	71	8	Yes
R-2349	A-4	B-Residential	66	62	70	8	Yes
R-2350	A-4	B-Residential	66	62	66	4	Yes
R-2351	A-4	B-Residential	66	64	72	8	Yes
R-2352	A-4	B-Residential	66	62	67	5	Yes
R-2353	A-4	B-Residential	66	62	66	4	Yes
R-2354	A-4	B-Residential	66	62	66	4	Yes
R-2355	A-4	B-Residential	66	65	74	9	Yes
R-2356	A-4	B-Residential	66	62	64	2	No
R-2357	A-4	B-Residential	66	62	70	8	Yes
R-2358	A-4	B-Residential	66	63	71	8	Yes
R-2359	A-4	B-Residential	66	62	66	4	Yes
R-2360	A-4	B-Residential	66	62	60	-2	No
R-2361	A-4	B-Residential	66	62	63	1	No
R-2362	A-4	B-Residential	66	62	65	3	No
R-2363	A-4	B-Residential	66	62	71	9	Yes
R-2364	A-4	B-Residential	66	62	68	6	Yes
R-2365	A-4	B-Residential	66	62	65	3	No
R-2366	A-4	B-Residential	66	62	65	3	No
R-2367	A-4	B-Residential	66	66	75	9	Yes
R-2368	A-4	B-Residential	66	63	71	8	Yes
R-2369	A-4	B-Residential	66	62	63	1	No
R-2370	A-4	B-Residential	66	62	67	5	Yes
R-2371	A-4	B-Residential	66	62	66	4	Yes
R-2372	A-4	B-Residential	66	64	72	8	Yes
R-2373	A-4	B-Residential	66	62	70	8	Yes
R-2374	A-4	B-Residential	66	62	69	7	Yes
R-2375	A-4	B-Residential	66	62	72	10	Yes
R-2376	A-4	B-Residential	66	62	69	7	Yes
R-2377	A-4	B-Residential	66	62	66	4	Yes
R-2378	A-4	B-Residential	66	63	71	8	Yes
R-2379	A-4	B-Residential	66	62	66	4	Yes
R-2380	A-4	B-Residential	66	62	69	7	Yes
R-2381	A-4	B-Residential	66	62	67	5	Yes
R-2382	A-4	B-Residential	66	62	64	2	No
R-2383	A-4	B-Residential	66	63	71	8	Yes
R-2384	A-4	B-Residential	66	65	75	10	Yes
R-2385	A-4	B-Residential	66	62	68	6	Yes
R-2386	A-4	B-Residential	66	62	63	1	No

Traffic Noise Analysis Report Addendum – Preferred Alternative

Table 2. Segment A Traffic Noise Levels dB(A) Leq

Segment A Representative Receiver	Figure	NAC Category	NAC Level	Existing	Predicted 2050	Change (+/-)	Noise Impact (Yes/No)
R-2387	A-4	B-Residential	66	66	76	10	Yes
R-2388	A-4	B-Residential	66	62	65	3	No
R-2389	A-4	B-Residential	66	62	68	6	Yes
R-2390	A-4	B-Residential	66	62	69	7	Yes
R-2391	A-4	B-Residential	66	62	71	9	Yes
R-2392	A-4	B-Residential	66	66	75	9	Yes
R-2393	A-4	B-Residential	66	64	72	8	Yes
R-2394	A-4	B-Residential	66	62	69	7	Yes
R-2395	A-4	B-Residential	66	64	72	8	Yes
R-2396	A-4	B-Residential	66	62	64	2	No
R-2397	A-4	B-Residential	66	62	64	2	No
R-2398	A-4	B-Residential	66	62	67	5	Yes
R-2399	A-4	B-Residential	66	62	68	6	Yes
R-2400	A-4	B-Residential	66	62	66	4	Yes
R-2401	A-4	B-Residential	66	62	68	6	Yes
R-2402	A-4	B-Residential	66	62	65	3	No
R-2403	A-4	B-Residential	66	62	69	7	Yes
R-2404	A-4	B-Residential	66	64	73	9	Yes
R-2405	A-4	B-Residential	66	62	65	3	No
R-2406	A-4	B-Residential	66	66	76	10	Yes
R-2407	A-4	B-Residential	66	62	69	7	Yes
R-2408	A-4	B-Residential	66	63	71	8	Yes
R-2409	A-4	B-Residential	66	63	72	9	Yes
R-2410	A-4	B-Residential	66	62	69	7	Yes
R-2411	A-4	B-Residential	66	62	67	5	Yes
R-2412	A-4	B-Residential	66	62	65	3	No
R-2413	A-4	B-Residential	66	66	75	9	Yes
R-2414	A-4	B-Residential	66	62	66	4	Yes
R-2415	A-4	B-Residential	66	62	68	6	Yes
R-2416	A-4	B-Residential	66	62	68	6	Yes
R-2417	A-4	B-Residential	66	62	66	4	Yes
R-2418	A-4	B-Residential	66	62	71	9	Yes
R-2419	A-4	B-Residential	66	63	71	8	Yes
R-2420	A-4	B-Residential	66	62	64	2	No
R-2421	A-4	B-Residential	66	62	64	2	No
R-2422	A-4	B-Residential	66	62	68	6	Yes
R-2423	A-4	B-Residential	66	62	72	10	Yes
R-2424	A-4	B-Residential	66	62	65	3	No
R-2425	A-4	B-Residential	66	65	73	8	Yes

Traffic Noise Analysis Report Addendum – Preferred Alternative

Table 2. Segment A Traffic Noise Levels dB(A) Leq

Segment A Representative Receiver	Figure	NAC Category	NAC Level	Existing	Predicted 2050	Change (+/-)	Noise Impact (Yes/No)
R-2426	A-4	B-Residential	66	62	70	8	Yes
R-2427	A-4	B-Residential	66	62	65	3	No
R-2428	A-4	B-Residential	66	62	69	7	Yes
R-2429	A-4	B-Residential	66	62	63	1	No
R-2430	A-4	B-Residential	66	63	71	8	Yes
R-2431	A-4	B-Residential	66	62	67	5	Yes
R-2432	A-4	B-Residential	66	62	68	6	Yes
R-2433	A-4	B-Residential	66	62	69	7	Yes
R-2434	A-4	B-Residential	66	66	75	9	Yes
R-2435	A-4	B-Residential	66	62	64	2	No
R-2436	A-4	B-Residential	66	64	72	8	Yes
R-2437	A-4	B-Residential	66	62	63	1	No
R-2438	A-4	B-Residential	66	62	69	7	Yes
R-2439	A-4	B-Residential	66	63	71	8	Yes
R-2440	A-4	B-Residential	66	62	61	-1	No
R-2441	A-4	B-Residential	66	62	70	8	Yes
R-2442	A-4	B-Residential	66	62	66	4	Yes
R-2443	A-4	B-Residential	66	62	63	1	No
R-2444	A-4	B-Residential	66	65	75	10	Yes
R-2445	A-4	B-Residential	66	62	67	5	Yes
R-2446	A-4	B-Residential	66	62	61	-1	No
R-2447	A-4	B-Residential	66	64	72	8	Yes
R-2448	A-4	B-Residential	66	63	70	7	Yes
R-2449	A-4	B-Residential	66	62	65	3	No
R-2450	A-4	B-Residential	66	62	62	0	No
R-2451	A-4	B-Residential	66	62	68	6	Yes
R-2452	A-4	B-Residential	66	62	70	8	Yes
R-2453	A-4	B-Residential	66	62	67	5	Yes
R-2454	A-4	B-Residential	66	62	67	5	Yes
R-2455	A-4	B-Residential	66	62	67	5	Yes
R-2456	A-4	B-Residential	66	62	69	7	Yes
R-2457	A-4	B-Residential	66	62	67	5	Yes
R-2458	A-4	B-Residential	66	62	70	8	Yes
R-2459	A-4	B-Residential	66	62	69	7	Yes
R-2460	A-4	B-Residential	66	62	66	4	Yes
R-2461	A-4	B-Residential	66	63	70	7	Yes
R-2462	A-4	B-Residential	66	62	65	3	No
R-2463	A-4	B-Residential	66	62	62	0	No
R-2464	A-4	B-Residential	66	62	61	-1	No

Traffic Noise Analysis Report Addendum – Preferred Alternative

Table 2. Segment A Traffic Noise Levels dB(A) Leq

Segment A Representative Receiver	Figure	NAC Category	NAC Level	Existing	Predicted 2050	Change (+/-)	Noise Impact (Yes/No)
R-2465	A-4	B-Residential	66	62	63	1	No
R-2466	A-4	B-Residential	66	62	68	6	Yes
R-2467	A-4	B-Residential	66	62	66	4	Yes
R-2468	A-4	B-Residential	66	62	67	5	Yes
R-2469	A-4	B-Residential	66	62	69	7	Yes
R-2470	A-4	B-Residential	66	62	70	8	Yes
R-2471	A-4	B-Residential	66	62	65	3	No
R-2472	A-4	B-Residential	66	62	67	5	Yes
R-2473	A-4	B-Residential	66	62	67	5	Yes
R-2474	A-4	B-Residential	66	63	71	8	Yes
R-2475	A-4	B-Residential	66	66	76	10	Yes
R-2476	A-4	B-Residential	66	62	67	5	Yes
R-2477	A-4	B-Residential	66	62	60	-2	No
R-2478	A-4	B-Residential	66	62	66	4	Yes
R-2479	A-4	B-Residential	66	62	64	2	No
R-2480	A-4	B-Residential	66	62	69	7	Yes
R-2481	A-4	B-Residential	66	62	62	0	No
R-2482	A-4	B-Residential	66	66	75	9	Yes
R-2483	A-4	B-Residential	66	65	74	9	Yes
R-2484	A-4	B-Residential	66	62	69	7	Yes
R-2485	A-4	B-Residential	66	62	65	3	No
R-2486	A-4	B-Residential	66	63	69	6	Yes
R-2487	A-4	B-Residential	66	62	70	8	Yes
R-2488	A-4	B-Residential	66	62	67	5	Yes
R-2489	A-4	B-Residential	66	64	72	8	Yes
R-2490	A-4	B-Residential	66	62	68	6	Yes
R-2491	A-4	B-Residential	66	62	66	4	Yes
R-2492	A-4	B-Residential	66	63	70	7	Yes
R-2493	A-4	B-Residential	66	65	75	10	Yes
R-2494	A-4	B-Residential	66	63	71	8	Yes
R-2495	A-4	B-Residential	66	62	68	6	Yes
R-2683	A-11	B-Residential	66	70	64	-6	No
R-2684	A-8	C-Park	66	63	62	-1	No

Abbreviations: NAC, Noise Abatement Criteria; dB(A), A-weighted decibel; Leq, average/equivalent sound level.

As indicated in **Table 2**, the proposed project would result in a traffic noise impact at one or more representative receiver locations.

Noise abatement measures were considered for each location with predicted noise impacts.

Traffic Noise Analysis Report Addendum – Preferred Alternative

Abatement Analysis – Segment A

Feasible and Reasonable Barriers

Noise barriers would be feasible and reasonable for the following impacted receptors, and therefore, are proposed for incorporation into the Preferred Alternative. **Table 3** summarizes the proposed noise barriers.

Table 3. Segment A Proposed Noise Barriers

Barrier	Locations	Impacted Receptor Number (Type)	Number of Benefited Receptors	Length (feet)	Height (feet)	Total Barrier Area (ft ²)	Sq. Ft. / Benefited Receptor (ft ²)
A01	Prestwyck Neighborhood	R-51, R-61, and R-71 (Residential)	14	1,572	12	18,864	1,347
A07-2	Stonebridge Ranch	R-638 to R-649, R-652, R-658, R-662 to R-665, R-668, R-677, R-678, R-680 to R-686, R-688, R-689, R-693, R-699, R-700 to R-702, R-704 to R-706, R-709, R-715, R-719, R-720, R-722, R-725, R-727 to R-730, R-740, R-742, R-745, R-748, R-753, R-755, and R-764 (Residential)	20	943	18	16,974	849
A10	Kensington	R-818, R-820, and R-821 (Residential)	7	683	8	5,464	781
A11	New Development Chase at Wilson Creek*	R-1527 to R-1606, R-1608 to R-1610, R-1612 to R-1622, R-1624 to R-1626, R-1628 to R-1638, R-1640 to R-1642, R-1644 to R-1646, R-1648 to R-1654, R-1656 to R-1658, R-1670 to R-1672, R-1674 to R-1680, R-1682 to R-1688, R-1690 to R-1696, R-1698 to R-1704, R-1706 to R-1712, R-1714 to R-1716, R-1718 to R-1720, R-1722 to R-1724, R-1726 to R-1728, R-1730 to R-1732, R-1734 to R-1736, R-1738 to R-1740, R-1743, R-1744, R-1747, R-1748, R-1751, R-1752, R-1755, R-1756, R-1759, R-1760, R-1762 to R-1764, R-1766 to R-1768, R-1770 to R-1772, R-1775, R-1776, R-1778 to R-1784, R-1787, R-1788, R-1790 to R-1792, R-1794 to R-1800, R-1803, R-1804, R-1807,	162	3328	20	66,560	411

Traffic Noise Analysis Report Addendum – Preferred Alternative

Barrier	Locations	Impacted Receptor Number (Type)	Number of Benefited Receptors	Length (feet)	Height (feet)	Total Barrier Area (ft ²)	Sq. Ft. / Benefited Receptor (ft ²)
		R-1808, R-1810 to R-1816, R-1820, R-1824, R-1826 to R-1828, R-1830 to R-1832, R-1836, R-1839, R-1840, R-1842 to R-1844, R-1848, R-1851, R-1852, R-1856, R-1859, R-1860, R-1868, R-1888, R-1894 to R-1900, R-1922 to R-1928, R-1930 to R-1932, R-1934 to R-1936, R-1955, R-1956, R-1960, R-2007, R-2010, R-2011, R-2014, R-2015, R-2050, R-2051, R-2053 to R-2055, R-2058, R-2059, R-2061 to R-2063, R-2066, R-2067, R-2069, R-2070, R-2071, R-2074, R-2075, R-2077 to R-2079, R-2082, R-2083, R-2085, R-2087, R-2090, R-2091, R-2093 to R-2095, R-2098, R-2099, R-2101 to R-2103, R-2106, R-2107, R-2109 to R-2111, R-2114, R-2115, R-2117 to R-2119, R-2122, R-2123, R-2125 to R-2127, R-2130, R-2131, R-2133 to R-2135, R-2138, R-2139, R-2141 to R-2143 (Residential)					
A12	New Development Brookhollow*	R-2319 to R-2325, R-2327 to R-2330, R-2332, R-2334 to R-2337, R-2341 to R-2344, R-2346 to R-2355, R-2357 to R-2359, R-2363, R-2364, R-2367, R-2368, R-2370 to R-2381, R-2383 to R-2385, R-2387, R-2389 to R-2395, R-2398 to R-2401, R-2403, R-2404, R-2406 to R-2411, R-2413 to R-2419, R-2422, R-2423, R-2425, R-2426, R-2428, R-2430 to R-2434, R-2436, R-2438, R-2439, R-2441, R-2442, R-2444, R-2445, R-2447, R-2448, R-2451, R-2452, R-2453 to R-2466 to R-2470, R-2472 to R-	40	909	15	13,635	341

Traffic Noise Analysis Report Addendum – Preferred Alternative

Barrier	Locations	Impacted Receptor Number (Type)	Number of Benefited Receptors	Length (feet)	Height (feet)	Total Barrier Area (ft ²)	Sq. Ft. / Benefited Receptor (ft ²)
		2476, R-2478, R-2480, R-2482 to R-2484, R-2486 to R-2495 (Residential)					

*Note: This development is either under construction or permitted for development. At the time the noise model was conducted, none of the receptors in the development were present.

Barrier A01: R-51, R-61, and R-71 (Figure A-1 and Figure A-2) – These receivers represent a total of 3 (three) impacted residences at the Prestwyck Neighborhood along the Preferred Alternative. Based on preliminary calculations, a noise barrier 1,572 feet in length, 12 feet in height, and located along the proposed ROW would reduce noise levels by at least 5 dB(A) for 14 benefited receptors and meet the noise reduction design goal of 7 dB(A) for at least one of those receptors. With a total area of abatement of 18,864 square feet or 1,347 square feet per benefited receptor, the barrier would be cost reasonable. Therefore, Barrier A01 is considered acoustically feasible and cost effective.

Barrier A07-2: R-638 to R-649, R-652, R-658, R-662 to R-665, R-668, R-677, R-678, R-680 to R-686, R-688, R-689, R-693, R-699, R-700 to R-702, R-704 to R-706, R-709, R-715, R-719, R-720, R-722, R-725, R-727 to R-730, R-740, R-742, R-745, R-748, R-753, R-755, and R-764 (Figure A-8, and Figure A-9). Two alternatives are analyzed for this barrier, they are Barrier A07-1, and A07-2. Only Barrier A07-2 is reasonable and feasible. All alternatives cover the same receptors listed above.

Barrier A07-1: These receivers represent a total of 55 (fifty-five) impacted residences in the Stonebridge Ranch neighborhood along the Preferred Alternative. Based on preliminary calculations, a noise barrier 971 feet in length, 20 feet in height, and located between the off-ramp and the ROW would not be sufficient to achieve the minimum, feasible reduction of 5 dB(A) for a majority of impacted receptors or the noise reduction design goal of 7 dB(A).

Barrier A07-2: These receivers represent a total of 55 (fifty-five) impacted residences in the Stonebridge Ranch neighborhood along the Preferred Alternative. Based on preliminary calculations, a noise barrier 943 feet in length, 18 feet in height, and located along the proposed ROW would reduce noise levels by at least 5 dB(A) for 20 (twenty) benefited receptors and meet the noise reduction design goal of 7 dB(A) for at least one of those receptors. With a total area of abatement of 16,974 square feet or 849 square feet per benefited receptor, the barrier would be cost reasonable. Therefore, Barrier A07-2 is considered acoustically feasible and cost effective.

Barrier A10: R-818, R-820, and R-821 (Figure A-8, and Figure A-10) – These receivers represent a total of 3 (three) impacted residences at the Kensington Neighborhood along the Preferred Alternative. Based on preliminary calculations, a noise barrier 683 feet in length, 8 feet in height, and located along the proposed ROW would reduce noise levels by at least 5 dB(A) for 7 (seven) benefited receptors and meet the noise reduction design goal of 7 dB(A) for at least one of those receptors. With a total area of abatement of 5,464 square feet or 781 square feet per benefited receptor, the barrier would be cost reasonable. Therefore, Barrier A10 is considered acoustically feasible and cost effective.

Barrier A11: R-1527 to R-1606, R-1608 to R-1610, R-1612 to R-1622, R-1624 to R-1626, R-1628 to R-1638, R-1640 to R-1642, R-1644 to R-1646, R-1648 to R-1654, R-1656 to R-1658, R-1670 to R-1672, R-1674 to R-1680, R-1682 to R-1688, R-1690 to R-1696, R-1698 to R-1704, R-1706 to R-1712, R-1714 to R-1716, R-1718 to R-1720, R-1722 to R-1724, R-1726 to R-1728, R-1730 to R-1732, R-1734 to R-1736, R-1738 to R-1740, R-1743, R-1744, R-1747, R-1748, R-1751, R-1752, R-1755, R-1756, R-1759, R-1760, R-1762 to R-1764, R-1766 to R-1768, R-1770 to R-1772, R-1775, R-1776, R-1778 to R-1784, R-1787, R-1788, R-1790 to R-1792, R-1794 to R-1800, R-1803, R-1804, R-1807, R-1808, R-1810 to R-

Traffic Noise Analysis Report Addendum – Preferred Alternative

1816, R-1820, R-1824, R-1826 to R-1828, R-1830 to R-1832, R-1836, R-1839, R-1840, R-1842 to R-1844, R-1848, R-1851, R-1852, R-1856, R-1859, R-1860, R-1868, R-1888, R-1894 to R-1900, R-1922 to R-1928, R-1930 to R-1932, R-1934 to R-1936, R-1955, R-1956, R-1960, R-2007, R-2010, R-2011, R-2014, R-2015, R-2050, R-2051, R-2053 to R-2055, R-2058, R-2059, R-2061 to R-2063, R-2066, R-2067, R-2069, R-2070, R-2071, R-2074, R-2075, R-2077 to R-2079, R-2082, R-2083, R-2085, R-2087, R-2090, R-2091, R-2093 to R-2095, R-2098, R-2099, R-2101 to R-2103, R-2106, R-2107, R-2109 to R-2111, R-2114, R-2115, R-2117 to R-2119, R-2122, R-2123, R-2125 to R-2127, R-2130, R-2131, R-2133 to R-2135, R-2138, R-2139, R-2141 to R-2143 (Residential) (Figure A-10, Figure A-11, and Figure A-12) – These receivers represent a total of 344 (three hundred and forty-four) impacted residences at the new development Chase at Wilson Creek along the Preferred Alternative. Based on preliminary calculations, a noise barrier 3,328 feet in length, 20 feet in height, and located along the proposed ROW would reduce noise levels by at least 5 dB(A) for 162 (one hundred sixty-two) benefited receptors and meet the noise reduction design goal of 7 dB(A) for at least one of those receptors. With a total area of abatement of 66,560 square feet or 411 square feet per benefited receptor, the barrier would be cost reasonable. Therefore, Barrier A11 is considered acoustically feasible and cost effective.

Barrier A12: R-2319 to R-2325, R-2327 to R-2330, R-2332, R-2334 to R-2337, R-2341 to R-2344, R-2346 to R-2355, R-2357 to R-2359, R-2363, R-2364, R-2367, R-2368, R-2370 to R-2381, R-2383 to R-2385, R-2387, R-2389 to R-2395, R-2398 to R-2401, R-2403, R-2404, R-2406 to R-2411, R-2413 to R-2419, R-2422, R-2423, R-2425, R-2426, R-2428, R-2430 to R-2434, R-2436, R-2438, R-2439, R-2441, R-2442, R-2444, R-2445, R-2447, R-2448, R-2451, R-2452, R-2453 to R-2466 to R-2470, R-2472 to R-2476, R-2478, R-2480, R-2482 to R-2484, R-2486 to R-2495 (Figure A-3 and Figure A-4) – These receivers represent a total of 362 (three hundred and sixty-two) impacted residences/dwelling units at the new development at Brookhollow Neighborhood along the Preferred Alternative. Based on preliminary calculations, a noise barrier 909 feet in length, 15 feet in height, and located along the proposed ROW would reduce noise levels by at least 5 dB(A) for 40 (forty) benefited receptors and meet the noise reduction design goal of 7 dB(A) for at least one of those receptors. With a total area of abatement of 13,635 square feet or 341 square feet per benefited receptor, the barrier would be cost reasonable. Therefore, Barrier A12 is considered acoustically feasible and cost effective.

Barriers Analyzed But Not Proposed

Noise barriers would not be feasible and reasonable for any of the following impacted receptors, and therefore, are not proposed for incorporation into the project:

R-161, R-466, R-837, and R-894 - These receptors are separate, isolated residences, which are not associated with a neighborhood or subdivision. Because a noise abatement measure must potentially benefit a minimum of two impacted receptors, noise abatement for these locations is not feasible.

Barrier A02: R-474 and R-477 (Figure A-6 and Figure A-7)– These receivers represent a total of 4 (four) equivalent impacted dwelling units in La Cima Park along the Preferred Alternative. Based on preliminary calculations, a noise barrier 607 feet in length, 20 feet in height, and located along the proposed right of way (ROW) would not be sufficient to achieve the minimum, feasible reduction of 5 dB(A) for a majority of impacted receptors or the noise reduction design goal of 7 dB(A).

Barrier A04: R-483, R-485, R-489, R-492, and R-573 (Figure A-6, Figure A-7, and Figure A-8)- These receivers represent a total of 5 (five) impacted residences in the Stonebridge Ranch neighborhood along the Preferred Alternative. Based on preliminary calculations, a noise barrier 2,248 feet in length, 20 feet in height, and located along the proposed ROW would not be sufficient to achieve the minimum, feasible reduction of 5 dB(A) for a majority of impacted receptors or the noise reduction design goal of 7 dB(A).

Barrier A05: R-817, R-819 and R-822 (Figure A-13) - These receivers represent a total of 3 (three) impacted residences between STA 1519+00 and STA 1535+00 along the Preferred Alternative. Based on

Traffic Noise Analysis Report Addendum – Preferred Alternative

preliminary calculations, a noise barrier 1,637 feet in length, 20 feet in height, and located along the proposed ROW would not be sufficient to achieve the minimum, feasible reduction of 5 dB(A) for a majority of impacted receptors or the noise reduction design goal of 7 dB(A).

Barrier A06: R-863, R-884, and R-912 (Figure A-15, Figure A-16, and Figure A-17)- These receivers represent a total of 3 (three) impacted residential lots between STA 1545+00 and STA 1574+00 along the Preferred Alternative. Based on preliminary calculations, a noise barrier 3,180 feet in length, 20 feet in height, and located along the proposed ROW would not be sufficient to achieve the minimum, feasible reduction of 5 dB(A) for a majority of impacted receptors or the noise reduction design goal of 7 dB(A).

Barrier A08: R-900, R-901, R-918, R-919, R-925, R-939 and R-946 (Figure A-13)- These receivers represent a total of 98 (ninety-eight) equivalent dwelling units in the Zinger Bat Ball Park along the Preferred Alternative. Based on preliminary calculations, a noise barrier 1,498 feet in length, 20 feet in height, and located along the proposed ROW would not be sufficient to achieve the minimum, feasible reduction of 5 dB(A) for a majority of impacted receptors or the noise reduction design goal of 7 dB(A).

Barrier A09: R-127, R-131, R-135, R-139, R-147, R-153, R-155, R-157, and R-159 (Figure A-2) – These receivers represent a total of 9 (nine) equivalent dwelling units in the Red Bud Estates neighborhood along the Preferred Alternative. A continuous noise barrier 20 feet in height and approximately 1,829 feet in length was modeled along the proposed ROW. This barrier would achieve the minimum feasible reduction of 5 dB(A) for 4 (four) receptors while meeting the 7 dB(A) noise reduction design goal at one of those receptors. However, the square footage of abatement (36,580 square feet or 9,145 square feet per benefited receptor) would exceed the reasonable, cost-reasonableness criterion of 1,500 square feet per benefited receptor.

Barrier A13: R-225, R-231, R-237, R-241, and R-243 (Figure A-3)- These receivers represent a total of 5 (five) equivalent dwelling units in the new development at Hidden Lakes along the Preferred Alternative. Based on preliminary calculations, a noise barrier 916 feet in length, 20 feet in height, and located along the proposed ROW would not be sufficient to achieve the minimum, feasible reduction of 5 dB(A) for a majority of impacted receptors or the noise reduction design goal of 7 dB(A).

Segment C

Segment C serves as the eastern portion of the Preferred Alternative. Segment C begins at SH 5 extending in a southeasterly direction across the Dallas Area Transit (DART) rail line and the East Fork Trinity River, then shifts to a more southerly direction east of and parallel to the East Fork Trinity River to connect to existing US 380 near FM 1827.

Results – Segment C

Table 4 provides a summary of the traffic noise impacts for Segment C according to evaluated land-use receptors.

Table 4. Summary of Traffic Noise Impacts for Segment C

NAC	RECEPTORS	IMPACTS
A	0	0
B	104	42
C	1	1
D	0	0
E	0	0
Total	105	43

Traffic Noise Analysis Report Addendum – Preferred Alternative

Existing and predicted traffic noise levels for Segment C were modeled at receiver locations listed in **Table 5** that represent the land use activity areas adjacent to the proposed project that might be impacted by traffic noise and potentially benefit from feasible and reasonable noise abatement.

Table 5. Segment C Traffic Noise Levels dB(A) Leq

Segment C Representative Receiver	Figure	NAC Category	NAC Level	Existing	Predicted 2050	Change (+/-)	Noise Impact (Yes/No)
R-1384	C-1	B-Residential	66	52	57	5	No
R-1386	C-1	B-Residential	66	52	57	5	No
R-1388	C-1	B-Residential	66	52	57	5	No
R-1389	C-1	B-Residential	66	52	56	4	No
R-1390	C-1	B-Residential	66	52	56	4	No
R-1391	C-1	B-Residential	66	52	56	4	No
R-1392	C-1	B-Residential	66	52	55	3	No
R-1393	C-1	B-Residential	66	52	57	5	No
R-1394	C-1	B-Residential	66	52	59	7	No
R-1395	C-1	B-Residential	66	52	58	6	No
R-1396	C-1	B-Residential	66	52	55	3	No
R-1397	C-1	B-Residential	66	52	55	3	No
R-1398	C-1	B-Residential	66	52	55	3	No
R-1399	C-1	B-Residential	66	52	55	3	No
R-1400	C-1	B-Residential	66	52	54	2	No
R-1401	C-1	B-Residential	66	52	55	3	No
R-1402	C-1	B-Residential	66	52	54	2	No
R-1403	C-1	B-Residential	66	52	57	5	No
R-1404	C-1	B-Residential	66	52	55	3	No
R-1405	C-1	B-Residential	66	52	54	2	No
R-1406	C-1	B-Residential	66	52	54	2	No
R-1407	C-1	B-Residential	66	52	57	5	No
R-1408	C-1	B-Residential	66	52	54	2	No
R-1409	C-1	B-Residential	66	52	57	5	No
R-1410	C-1	B-Residential	66	52	57	5	No
R-1411	C-1	B-Residential	66	52	56	4	No
R-1412	C-1	B-Residential	66	52	54	2	No
R-1413	C-1	B-Residential	66	52	58	6	No
R-1414	C-1	B-Residential	66	52	54	2	No
R-1415	C-1	B-Residential	66	52	57	5	No
R-1416	C-1	B-Residential	66	52	57	5	No
R-1417	C-1	B-Residential	66	52	54	2	No
R-1418	C-1	B-Residential	66	52	56	4	No
R-1419	C-1	B-Residential	66	52	58	6	No

Traffic Noise Analysis Report Addendum – Preferred Alternative

Table 5. Segment C Traffic Noise Levels dB(A) Leq

Segment C Representative Receiver	Figure	NAC Category	NAC Level	Existing	Predicted 2050	Change (+/-)	Noise Impact (Yes/No)
R-1420	C-1	B-Residential	66	52	53	1	No
R-1421	C-1	B-Residential	66	52	56	4	No
R-1422	C-1	B-Residential	66	52	54	2	No
R-1423	C-1	B-Residential	66	52	53	1	No
R-1424	C-1	B-Residential	66	52	56	4	No
R-1425	C-1	B-Residential	66	52	53	1	No
R-1426	C-1	B-Residential	66	52	52	0	No
R-1427	C-1	B-Residential	66	52	54	2	No
R-1428	C-1	B-Residential	66	52	53	1	No
R-1429	C-1	B-Residential	66	52	54	2	No
R-1431	C-3	B-Residential	66	52	57	5	No
R-1432	C-3	B-Residential	66	52	56	4	No
R-1433	C-4	B-Residential	66	52	67	15	Yes
R-1434	C-8	C-Park	66	69	68	-1	Yes
R-1436	C-5	B-Residential	66	57	57	0	No
R-1437	C-3	B-Residential	66	52	56	4	No
R-1438	C-6	B-Residential	66	60	67	7	Yes
R-1439	C-6	B-Residential	66	60	65	5	No
R-1440	C-6	B-Residential	66	60	67	7	Yes
R-1441	C-6	B-Residential	66	60	62	2	No
R-1442	C-6	B-Residential	66	57	63	6	No
R-1443	C-7	B-Residential	66	60	67	7	Yes
R-1444	C-4	B-Residential	66	52	60	8	No
R-1445	C-6	B-Residential	66	60	65	5	No
R-1446	C-7	B-Residential	66	60	69	9	Yes
R-1447	C-6	B-Residential	66	60	67	7	Yes
R-1448	C-6	B-Residential	66	60	65	5	No
R-1449	C-5	B-Residential	66	57	65	8	No
R-1450	C-5	B-Residential	66	57	63	6	No
R-1451	C-6	B-Residential	66	60	64	4	No
R-1452	C-5	B-Residential	66	57	58	1	No
R-1453	C-5	B-Residential	66	57	60	3	No
R-1454	C-5	B-Residential	66	57	58	1	No
R-1455	C-5	B-Residential	66	57	59	2	No
R-1456	C-7	B-Residential	66	60	67	7	Yes
R-1457	C-7	B-Residential	66	60	65	5	No
R-1458	C-7	B-Residential	66	60	69	9	Yes
R-1459	C-10	B-Residential	66	69	77	8	Yes
R-1461	C-9	B-Residential	66	60	74	14	Yes

Traffic Noise Analysis Report Addendum – Preferred Alternative

Table 5. Segment C Traffic Noise Levels dB(A) Leq

Segment C Representative Receiver	Figure	NAC Category	NAC Level	Existing	Predicted 2050	Change (+/-)	Noise Impact (Yes/No)
R-1463	C-9	B-Residential	66	60	74	14	Yes
R-1465	C-9	B-Residential	66	60	74	14	Yes
R-1467	C-9	B-Residential	66	60	73	13	Yes
R-1469	C-9	B-Residential	66	60	70	10	Yes
R-1471	C-9	B-Residential	66	60	74	14	Yes
R-1473	C-9	B-Residential	66	60	77	17	Yes
R-1475	C-9	B-Residential	66	60	75	15	Yes
R-1477	C-9	B-Residential	66	60	73	13	Yes
R-1479	C-9	B-Residential	66	60	82	22	Yes
R-1481	C-9	B-Residential	66	60	77	17	Yes
R-1483	C-9	B-Residential	66	60	80	20	Yes
R-1485	C-9	B-Residential	66	60	78	18	Yes
R-1487	C-9	B-Residential	66	60	78	18	Yes
R-1489	C-9	B-Residential	66	60	76	16	Yes
R-1491	C-10	B-Residential	66	69	83	14	Yes
R-1493	C-9	B-Residential	66	69	80	11	Yes
R-1495	C-10	B-Residential	66	69	70	1	Yes
R-1497	C-10	B-Residential	66	69	67	-2	Yes
R-1499	C-9	B-Residential	66	69	74	5	Yes
R-1501	C-9	B-Residential	66	69	79	10	Yes
R-1503	C-10	B-Residential	66	69	76	7	Yes
R-1505	C-9	B-Residential	66	69	69	0	Yes
R-1507	C-9	B-Residential	66	69	68	-1	Yes
R-1509	C-11	B-Residential	66	69	66	-3	Yes
R-1511	C-11	B-Residential	66	69	67	-2	Yes
R-1513	C-11	B-Residential	66	69	67	-2	Yes
R-1515	C-11	B-Residential	66	69	67	-2	Yes
R-1517	C-11	B-Residential	66	69	68	-1	Yes
R-1519	C-11	B-Residential	66	69	72	3	Yes
R-1524	C-11	B-Residential	66	69	66	-3	Yes
R-2678	C-11	B-Residential	66	69	70	1	Yes
R-2679	C-11	B-Residential	66	69	69	0	Yes

Abbreviations: NAC, Noise Abatement Criteria; dB(A), A-weighted decibel; Leq, average/equivalent sound level.

As indicated in **Table 5**, the proposed project would result in a traffic noise impact at one or more representative receiver locations. Noise abatement measures were considered for each location with predicted noise impacts.

Traffic Noise Analysis Report Addendum – Preferred Alternative

Abatement Analysis – Segment C

No barriers were found to be feasible or reasonable.

Barriers Analyzed But Not Proposed –

Noise barriers would not be feasible and reasonable for any of the following impacted receptors, and therefore, are not proposed for incorporation into the project:

R-1433 is a separate, isolated residence, which is not associated with a neighborhood or subdivision. Because a noise abatement measure must potentially benefit a minimum of two impacted receptors, noise abatement for this location is not feasible.

Barrier C03: R-1438, R-1440, R-1443, R-1446, and R-1447 (Figure C-6, and Figure C-7)– These receivers represent a total of 5 (five) equivalent dwelling units between STA 2051+50 and STA 2060+00 along the Preferred Alternative. Based on preliminary calculations, a noise barrier 877 feet in length, 20 feet in height, and located along the proposed ROW would not be sufficient to achieve the minimum, feasible reduction of 5 dB(A) for a majority of impacted receptors or the noise reduction design goal of 7 dB(A).

Barrier C04: R-1456, and R-1458 (Figure C-6, and Figure C-7)– These receivers represent a total of 2 (two) equivalent dwelling units between STA 2054+00 and STA 2062+00 along the Preferred Alternative. Based on preliminary calculations, a noise barrier 847 feet in length, 20 feet in height, and located along the proposed ROW would not be sufficient to achieve the minimum, feasible reduction of 5 dB(A) for a majority of impacted receptors or the noise reduction design goal of 7 dB(A).

Barrier C05: R-1509, R-1511, R-1513, R-1515, R-1517, R-1519, R-1524, R-2678, and R-2679 (Figure C-9)– These receivers represent a total of 9 (nine) equivalent dwelling units between STA 2114+50 and STA 2122+00 along the Preferred Alternative. Based on preliminary calculations, a noise barrier 1,642 feet in length, 20 feet in height, and located along the proposed ROW would not be sufficient to achieve the minimum, feasible reduction of 5 dB(A) for a majority of impacted receptors or the noise reduction design goal of 7 dB(A).

Barrier C06: R-1461, R-1463, R-1465, R-1467, R-1469, R-1471, R-1473, R-1475, R-1477, R-1479, R-1481, R-1483, R-1485, R-1487, R-1489 (Figure C-7, Figure C-8, and Figure C-9)– These receivers represent a total of 15 (fifteen) equivalent dwelling units between STA 2068+50 and STA 2092+00 along the Preferred Alternative. Based on preliminary calculations, a noise barrier 2,187 feet in length, 20 feet in height, and located along the proposed ROW would not be sufficient to achieve the minimum, feasible reduction of 5 dB(A) for a majority of impacted receptors or the noise reduction design goal of 7 dB(A).

Barrier C07: R-1491, R-1493, R-1495, R-1497, R-1499, R-1501, R-1503, R-1505, and R-1507 (Figure C-9)– These receivers represent a total of 9 (nine) equivalent dwelling units between STA 2104+50 and STA 2114+00 along the Preferred Alternative. Based on preliminary calculations, a noise barrier 1,118 feet in length, 20 feet in height, and located between the proposed roadway and the proposed ROW would not be sufficient to achieve the minimum, feasible reduction of 5 dB(A) for a majority of impacted receptors or the noise reduction design goal of 7 dB(A).

Barrier C08: R-1434 and R-1459 (Figure C-8)– These receivers represent a total of 776 (seven hundred and seventy-six) equivalent dwelling units at McKinney Park Land along the Preferred Alternative. Based on preliminary calculations, a noise barrier 9,510 feet in length, 20 feet in height, and located along the proposed ROW would not be sufficient to achieve the minimum, feasible reduction of 5 dB(A) for a majority of impacted receptors or the noise reduction design goal of 7 dB(A).

Traffic Noise Analysis Report Addendum – Preferred Alternative

Segment E

Segment E serves as the central portion of the Preferred Alternative. Segment E extends roughly along the alignment of existing Bloomdale Road through north McKinney beginning at the proposed intersection of Ridge Road and Bloomdale Road on the west and SH 5 on the east. This segment includes a new interchange connection with US 75 and SH 5.

Results – Segment E

Table 6 provides of summary of the traffic noise impacts for Segment E according to evaluated land-use receptors.

Table 6. Summary of Traffic Noise Impacts for Segment E

NAC	RECEPTORS	IMPACTS
A	0	0
B	736	336
C	4	3
D	0	0
E	1	0
Total	741	339

Existing and predicted traffic noise levels for Segment E were modeled at receiver locations listed in **Table 7** that represent the land use activity areas adjacent to the proposed project that might be impacted by traffic noise and potentially benefit from feasible and reasonable noise abatement.

Table 7. Segment E Traffic Noise Levels dB(A) Leq

Segment E Representative Receiver	Figure	NAC Category	NAC Level	Existing	Predicted 2050	Change (+/-)	Noise Impact (Yes/No)
R-859	E-1	B-Residential	66	55	49	-6	No
R-861	E-1	B-Residential	66	55	48	-7	No
R-862	E-1	B-Residential	66	55	48	-7	No
R-864	E-1	B-Residential	66	55	48	-7	No
R-865	E-1	B-Residential	66	55	50	-5	No
R-866	E-1	B-Residential	66	55	48	-7	No
R-868	E-1	B-Residential	66	55	50	-5	No
R-869	E-1	B-Residential	66	55	48	-7	No
R-871	E-1	B-Residential	66	55	50	-5	No
R-872	E-1	B-Residential	66	55	50	-5	No
R-874	E-1	B-Residential	66	55	48	-7	No
R-875	E-1	B-Residential	66	55	52	-3	No
R-876	E-1	B-Residential	66	55	47	-8	No
R-878	E-1	B-Residential	66	55	47	-8	No
R-879	E-1	B-Residential	66	55	47	-8	No

Traffic Noise Analysis Report Addendum – Preferred Alternative

Table 7. Segment E Traffic Noise Levels dB(A) Leq

Segment E Representative Receiver	Figure	NAC Category	NAC Level	Existing	Predicted 2050	Change (+/-)	Noise Impact (Yes/No)
R-880	E-1	B-Residential	66	55	47	-8	No
R-882	E-1	B-Residential	66	55	47	-8	No
R-883	E-1	B-Residential	66	55	47	-8	No
R-885	E-1	B-Residential	66	55	47	-8	No
R-886	E-1	B-Residential	66	55	46	-9	No
R-888	E-1	B-Residential	66	55	46	-9	No
R-889	E-1	B-Residential	66	55	46	-9	No
R-890	E-1	B-Residential	66	55	50	-5	No
R-891	E-1	B-Residential	66	55	46	-9	No
R-892	E-1	B-Residential	66	55	49	-6	No
R-893	E-1	B-Residential	66	55	45	-10	No
R-896	E-1	B-Residential	66	55	51	-4	No
R-897	E-1	B-Residential	66	55	48	-7	No
R-898	E-1	B-Residential	66	55	45	-10	No
R-899	E-1	B-Residential	66	55	50	-5	No
R-902	E-1	B-Residential	66	55	53	-2	No
R-903	E-1	B-Residential	66	55	49	-6	No
R-904	E-1	B-Residential	66	55	48	-7	No
R-905	E-1	B-Residential	66	55	51	-4	No
R-906	E-1	B-Residential	66	55	46	-9	No
R-907	E-1	B-Residential	66	55	47	-8	No
R-908	E-1	B-Residential	66	55	53	-2	No
R-909	E-1	B-Residential	66	55	49	-6	No
R-910	E-1	B-Residential	66	55	50	-5	No
R-911	E-1	B-Residential	66	55	51	-4	No
R-914	E-1	B-Residential	66	55	48	-7	No
R-915	E-1	B-Residential	66	55	47	-8	No
R-916	E-1	B-Residential	66	55	54	-1	No
R-917	E-1	B-Residential	66	55	49	-6	No
R-920	E-1	B-Residential	66	55	51	-4	No
R-921	E-1	B-Residential	66	55	52	-3	No
R-922	E-1	B-Residential	66	55	47	-8	No
R-923	E-1	B-Residential	66	55	48	-7	No
R-924	E-1	B-Residential	66	55	55	0	No
R-926	E-1	B-Residential	66	55	50	-5	No
R-927	E-1	B-Residential	66	55	52	-3	No
R-928	E-1	B-Residential	66	55	53	-2	No
R-929	E-1	B-Residential	66	55	48	-7	No
R-930	E-1	B-Residential	66	55	49	-6	No

Traffic Noise Analysis Report Addendum – Preferred Alternative

Table 7. Segment E Traffic Noise Levels dB(A) Leq

Segment E Representative Receiver	Figure	NAC Category	NAC Level	Existing	Predicted 2050	Change (+/-)	Noise Impact (Yes/No)
R-931	E-1	B-Residential	66	55	55	0	No
R-932	E-1	B-Residential	66	55	50	-5	No
R-933	E-1	B-Residential	66	55	52	-3	No
R-934	E-1	B-Residential	66	55	54	-1	No
R-935	E-1	B-Residential	66	55	48	-7	No
R-936	E-1	B-Residential	66	55	49	-6	No
R-937	E-1	B-Residential	66	55	56	1	No
R-938	E-1	B-Residential	66	55	51	-4	No
R-940	E-1	B-Residential	66	55	53	-2	No
R-941	E-1	B-Residential	66	55	55	0	No
R-942	E-1	B-Residential	66	55	49	-6	No
R-943	E-1	B-Residential	66	55	50	-5	No
R-944	E-1	B-Residential	66	55	57	2	No
R-945	E-1	B-Residential	66	55	51	-4	No
R-947	E-1	B-Residential	66	55	50	-5	No
R-949	E-1	B-Residential	66	55	52	-3	No
R-950	E-1	B-Residential	66	55	51	-4	No
R-951	E-1	B-Residential	66	55	58	3	No
R-952	E-1	B-Residential	66	55	46	-9	No
R-953	E-1	B-Residential	66	55	47	-8	No
R-954	E-1	B-Residential	66	55	52	-3	No
R-955	E-1	B-Residential	66	55	47	-8	No
R-956	E-1	B-Residential	66	55	53	-2	No
R-957	E-1	B-Residential	66	55	47	-8	No
R-958	E-1	B-Residential	66	55	48	-7	No
R-959	E-1	B-Residential	66	55	49	-6	No
R-960	E-1	B-Residential	66	55	51	-4	No
R-961	E-1	B-Residential	66	55	51	-4	No
R-962	E-1	B-Residential	66	55	50	-5	No
R-963	E-1	B-Residential	66	55	50	-5	No
R-964	E-1	B-Residential	66	55	50	-5	No
R-965	E-1	B-Residential	66	55	54	-1	No
R-966	E-1	B-Residential	66	55	55	0	No
R-967	E-1	B-Residential	66	55	56	1	No
R-968	E-1	B-Residential	66	55	56	1	No
R-969	E-1	B-Residential	66	55	58	3	No
R-970	E-1	B-Residential	66	55	57	2	No
R-972	E-1	B-Residential	66	55	54	-1	No
R-973	E-1	B-Residential	66	55	54	-1	No

Traffic Noise Analysis Report Addendum – Preferred Alternative

Table 7. Segment E Traffic Noise Levels dB(A) Leq

Segment E Representative Receiver	Figure	NAC Category	NAC Level	Existing	Predicted 2050	Change (+/-)	Noise Impact (Yes/No)
R-974	E-1	B-Residential	66	55	46	-9	No
R-976	E-1	B-Residential	66	55	47	-8	No
R-977	E-1	B-Residential	66	55	49	-6	No
R-978	E-1	B-Residential	66	55	49	-6	No
R-979	E-1	B-Residential	66	55	50	-5	No
R-980	E-1	B-Residential	66	55	49	-6	No
R-981	E-1	B-Residential	66	55	49	-6	No
R-982	E-1	B-Residential	66	55	48	-7	No
R-983	E-1	B-Residential	66	55	56	1	No
R-984	E-1	B-Residential	66	55	56	1	No
R-985	E-1	B-Residential	66	55	55	0	No
R-986	E-1	B-Residential	66	55	57	2	No
R-987	E-1	B-Residential	66	55	56	1	No
R-988	E-1	B-Residential	66	55	57	2	No
R-989	E-1	B-Residential	66	55	57	2	No
R-990	E-1	B-Residential	66	55	48	-7	No
R-991	E-1	B-Residential	66	55	57	2	No
R-992	E-1	B-Residential	66	55	57	2	No
R-993	E-1	E-Commercial	71	55	63	8	No
R-994	E-3	B-Residential	66	55	57	2	No
R-995	E-3	B-Residential	66	55	55	0	No
R-996	E-3	B-Residential	66	55	53	-2	No
R-997	E-3	B-Residential	66	55	52	-3	No
R-998	E-3	B-Residential	66	55	52	-3	No
R-999	E-3	B-Residential	66	55	58	3	No
R-1000	E-3	B-Residential	66	55	58	3	No
R-1001	E-3	B-Residential	66	55	55	0	No
R-1002	E-3	B-Residential	66	55	54	-1	No
R-1003	E-2	B-Residential	66	55	57	2	No
R-1004	E-3	B-Residential	66	55	57	2	No
R-1005	E-3	B-Residential	66	55	55	0	No
R-1006	E-3	B-Residential	66	55	54	-1	No
R-1007	E-3	B-Residential	66	55	57	2	No
R-1008	E-3	B-Residential	66	55	55	0	No
R-1009	E-3	B-Residential	66	55	54	-1	No
R-1010	E-3	B-Residential	66	55	56	1	No
R-1011	E-3	B-Residential	66	55	55	0	No
R-1012	E-3	B-Residential	66	55	54	-1	No
R-1013	E-3	B-Residential	66	55	56	1	No

Traffic Noise Analysis Report Addendum – Preferred Alternative

Table 7. Segment E Traffic Noise Levels dB(A) Leq

Segment E Representative Receiver	Figure	NAC Category	NAC Level	Existing	Predicted 2050	Change (+/-)	Noise Impact (Yes/No)
R-1014	E-3	B-Residential	66	55	54	-1	No
R-1015	E-3	B-Residential	66	55	56	1	No
R-1016	E-3	B-Residential	66	55	60	5	No
R-1017	E-3	B-Residential	66	55	60	5	No
R-1018	E-3	B-Residential	66	55	60	5	No
R-1019	E-3	B-Residential	66	55	59	4	No
R-1020	E-3	B-Residential	66	55	58	3	No
R-1021	E-3	B-Residential	66	55	58	3	No
R-1022	E-3	B-Residential	66	55	57	2	No
R-1023	E-3	B-Residential	66	55	60	5	No
R-1024	E-3	B-Residential	66	55	62	7	No
R-1025	E-3	B-Residential	66	55	61	6	No
R-1026	E-3	B-Residential	66	55	59	4	No
R-1027	E-3	B-Residential	66	55	62	7	No
R-1028	E-3	B-Residential	66	55	61	6	No
R-1029	E-3	B-Residential	66	55	59	4	No
R-1030	E-2	B-Residential	66	55	59	4	No
R-1031	E-3	B-Residential	66	55	62	7	No
R-1032	E-3	B-Residential	66	55	61	6	No
R-1033	E-3	B-Residential	66	55	60	5	No
R-1034	E-3	B-Residential	66	55	61	6	No
R-1035	E-3	B-Residential	66	55	61	6	No
R-1036	E-3	B-Residential	66	55	60	5	No
R-1037	E-3	B-Residential	66	55	61	6	No
R-1038	E-3	B-Residential	66	55	61	6	No
R-1039	E-3	B-Residential	66	55	60	5	No
R-1040	E-3	B-Residential	66	55	60	5	No
R-1041	E-3	B-Residential	66	55	61	6	No
R-1042	E-3	B-Residential	66	55	60	5	No
R-1043	E-3	B-Residential	66	55	60	5	No
R-1044	E-3	B-Residential	66	55	61	6	No
R-1045	E-3	B-Residential	66	55	59	4	No
R-1046	E-3	B-Residential	66	55	59	4	No
R-1047	E-3	B-Residential	66	55	61	6	No
R-1048	E-3	B-Residential	66	55	59	4	No
R-1049	E-2	B-Residential	66	55	59	4	No
R-1050	E-3	B-Residential	66	55	60	5	No
R-1051	E-3	B-Residential	66	55	59	4	No
R-1052	E-3	B-Residential	66	55	58	3	No

Traffic Noise Analysis Report Addendum – Preferred Alternative

Table 7. Segment E Traffic Noise Levels dB(A) Leq

Segment E Representative Receiver	Figure	NAC Category	NAC Level	Existing	Predicted 2050	Change (+/-)	Noise Impact (Yes/No)
R-1053	E-3	B-Residential	66	55	57	2	No
R-1054	E-2	B-Residential	66	55	60	5	No
R-1055	E-3	B-Residential	66	55	58	3	No
R-1056	E-3	B-Residential	66	55	58	3	No
R-1057	E-3	B-Residential	66	57	61	4	No
R-1058	E-3	B-Residential	66	55	59	4	No
R-1059	E-3	B-Residential	66	55	58	3	No
R-1060	E-3	B-Residential	66	55	59	4	No
R-1061	E-3	B-Residential	66	58	60	2	No
R-1062	E-3	B-Residential	66	55	58	3	No
R-1063	E-3	B-Residential	66	55	59	4	No
R-1064	E-3	B-Residential	66	58	60	2	No
R-1065	E-3	B-Residential	66	55	58	3	No
R-1066	E-3	B-Residential	66	55	59	4	No
R-1067	E-3	B-Residential	66	58	60	2	No
R-1068	E-3	B-Residential	66	55	57	2	No
R-1069	E-3	B-Residential	66	55	59	4	No
R-1070	E-3	B-Residential	66	58	60	2	No
R-1071	E-3	B-Residential	66	55	57	2	No
R-1072	E-3	B-Residential	66	55	59	4	No
R-1073	E-3	B-Residential	66	58	60	2	No
R-1074	E-3	B-Residential	66	55	57	2	No
R-1075	E-3	B-Residential	66	55	59	4	No
R-1076	E-3	B-Residential	66	57	60	3	No
R-1077	E-3	B-Residential	66	55	57	2	No
R-1078	E-2	B-Residential	66	55	61	6	No
R-1079	E-3	B-Residential	66	55	59	4	No
R-1080	E-3	B-Residential	66	57	60	3	No
R-1081	E-3	B-Residential	66	55	57	2	No
R-1082	E-3	B-Residential	66	55	59	4	No
R-1083	E-3	B-Residential	66	58	58	0	No
R-1084	E-3	B-Residential	66	55	56	1	No
R-1085	E-3	B-Residential	66	55	59	4	No
R-1086	E-3	B-Residential	66	58	57	-1	No
R-1087	E-3	B-Residential	66	55	55	0	No
R-1088	E-3	B-Residential	66	55	59	4	No
R-1089	E-3	B-Residential	66	58	58	0	No
R-1090	E-3	B-Residential	66	55	55	0	No
R-1091	E-3	B-Residential	66	55	60	5	No

Traffic Noise Analysis Report Addendum – Preferred Alternative

Table 7. Segment E Traffic Noise Levels dB(A) Leq

Segment E Representative Receiver	Figure	NAC Category	NAC Level	Existing	Predicted 2050	Change (+/-)	Noise Impact (Yes/No)
R-1092	E-3	B-Residential	66	58	58	0	No
R-1093	E-3	B-Residential	66	55	55	0	No
R-1094	E-3	B-Residential	66	55	60	5	No
R-1095	E-3	B-Residential	66	58	57	-1	No
R-1096	E-3	B-Residential	66	55	55	0	No
R-1097	E-3	B-Residential	66	55	60	5	No
R-1098	E-3	B-Residential	66	58	57	-1	No
R-1099	E-3	B-Residential	66	55	55	0	No
R-1100	E-3	B-Residential	66	55	60	5	No
R-1101	E-3	B-Residential	66	58	58	0	No
R-1102	E-3	B-Residential	66	55	55	0	No
R-1103	E-3	B-Residential	66	55	60	5	No
R-1104	E-3	B-Residential	66	58	58	0	No
R-1105	E-3	B-Residential	66	55	56	1	No
R-1106	E-3	B-Residential	66	55	60	5	No
R-1107	E-3	B-Residential	66	58	57	-1	No
R-1108	E-3	B-Residential	66	55	56	1	No
R-1109	E-5	B-Residential	66	55	59	4	No
R-1110	E-3	B-Residential	66	58	58	0	No
R-1111	E-3	B-Residential	66	55	56	1	No
R-1112	E-5	B-Residential	66	55	59	4	No
R-1113	E-5	B-Residential	66	57	58	1	No
R-1114	E-3	B-Residential	66	55	56	1	No
R-1115	E-5	B-Residential	66	55	59	4	No
R-1116	E-5	B-Residential	66	58	57	-1	No
R-1117	E-5	B-Residential	66	55	56	1	No
R-1118	E-5	B-Residential	66	55	60	5	No
R-1119	E-5	B-Residential	66	58	58	0	No
R-1120	E-5	B-Residential	66	55	57	2	No
R-1121	E-5	B-Residential	66	56	59	3	No
R-1122	E-5	B-Residential	66	60	58	-2	No
R-1123	E-5	B-Residential	66	55	57	2	No
R-1124	E-5	B-Residential	66	55	60	5	No
R-1125	E-5	B-Residential	66	55	58	3	No
R-1126	E-5	B-Residential	66	59	59	0	No
R-1127	E-5	B-Residential	66	55	60	5	No
R-1128	E-5	B-Residential	66	55	58	3	No
R-1129	E-5	B-Residential	66	57	59	2	No
R-1130	E-5	B-Residential	66	55	60	5	No

Traffic Noise Analysis Report Addendum – Preferred Alternative

Table 7. Segment E Traffic Noise Levels dB(A) Leq

Segment E Representative Receiver	Figure	NAC Category	NAC Level	Existing	Predicted 2050	Change (+/-)	Noise Impact (Yes/No)
R-1131	E-5	B-Residential	66	55	59	4	No
R-1132	E-5	B-Residential	66	56	59	3	No
R-1133	E-5	B-Residential	66	55	60	5	No
R-1134	E-5	B-Residential	66	55	59	4	No
R-1135	E-5	B-Residential	66	56	59	3	No
R-1136	E-5	B-Residential	66	55	60	5	No
R-1137	E-5	B-Residential	66	55	59	4	No
R-1138	E-4	B-Residential	66	55	64	9	No
R-1139	E-5	B-Residential	66	56	59	3	No
R-1140	E-5	B-Residential	66	55	61	6	No
R-1141	E-5	B-Residential	66	55	60	5	No
R-1142	E-5	B-Residential	66	56	60	4	No
R-1143	E-5	B-Residential	66	55	61	6	No
R-1144	E-5	B-Residential	66	55	60	5	No
R-1145	E-5	B-Residential	66	56	60	4	No
R-1146	E-5	B-Residential	66	55	61	6	No
R-1147	E-5	B-Residential	66	55	61	6	No
R-1148	E-5	B-Residential	66	55	61	6	No
R-1149	E-5	B-Residential	66	55	62	7	No
R-1150	E-5	B-Residential	66	55	61	6	No
R-1151	E-5	B-Residential	66	55	62	7	No
R-1152	E-4	B-Residential	66	55	59	4	No
R-1153	E-5	B-Residential	66	55	62	7	No
R-1154	E-5	B-Residential	66	55	62	7	No
R-1155	E-5	B-Residential	66	56	62	6	No
R-1156	E-5	B-Residential	66	55	63	8	No
R-1157	E-5	B-Residential	66	55	62	7	No
R-1158	E-5	B-Residential	66	56	63	7	No
R-1159	E-5	B-Residential	66	55	63	8	No
R-1160	E-5	B-Residential	66	55	63	8	No
R-1161	E-5	B-Residential	66	56	64	8	No
R-1162	E-5	B-Residential	66	55	63	8	No
R-1163	E-5	B-Residential	66	55	63	8	No
R-1164	E-5	B-Residential	66	56	64	8	No
R-1165	E-5	B-Residential	66	55	63	8	No
R-1166	E-5	B-Residential	66	55	63	8	No
R-1167	E-5	B-Residential	66	56	64	8	No
R-1168	E-5	B-Residential	66	55	63	8	No
R-1169	E-5	B-Residential	66	55	63	8	No

Traffic Noise Analysis Report Addendum – Preferred Alternative

Table 7. Segment E Traffic Noise Levels dB(A) Leq

Segment E Representative Receiver	Figure	NAC Category	NAC Level	Existing	Predicted 2050	Change (+/-)	Noise Impact (Yes/No)
R-1170	E-4	B-Residential	66	55	66	11	Yes
R-1171	E-5	B-Residential	66	56	64	8	No
R-1172	E-5	B-Residential	66	55	64	9	No
R-1173	E-5	B-Residential	66	55	64	9	No
R-1174	E-5	B-Residential	66	56	65	9	No
R-1175	E-4	B-Residential	66	55	70	15	Yes
R-1176	E-5	B-Residential	66	55	64	9	No
R-1177	E-5	B-Residential	66	55	64	9	No
R-1178	E-5	B-Residential	66	56	66	10	Yes
R-1179	E-5	B-Residential	66	55	64	9	No
R-1180	E-5	B-Residential	66	55	62	7	No
R-1181	E-5	B-Residential	66	55	66	11	Yes
R-1182	E-5	B-Residential	66	55	67	12	Yes
R-1183	E-5	B-Residential	66	55	66	11	Yes
R-1184	E-5	B-Residential	66	55	66	11	Yes
R-1185	E-5	B-Residential	66	55	65	10	No
R-1186	E-5	B-Residential	66	55	64	9	No
R-1187	E-4	B-Residential	66	55	71	16	Yes
R-1188	E-4	B-Residential	66	55	70	15	Yes
R-1189	E-4	B-Residential	66	55	64	9	No
R-1190	E-7	B-Residential	66	55	65	10	No
R-1191	E-7	C-Park	66	39	57	18	Yes
R-1192	E-6	B-Residential	66	55	51	-4	No
R-1193	E-8	B-Residential	66	55	60	5	No
R-1194	E-9	B-Residential	66	51	60	9	No
R-1195	E-9	B-Residential	66	51	59	8	No
R-1196	E-9	B-Residential	66	51	62	11	Yes
R-1197	E-9	B-Residential	66	51	62	11	Yes
R-1198	E-9	B-Residential	66	51	62	11	Yes
R-1199	E-9	B-Residential	66	51	62	11	Yes
R-1200	E-9	B-Residential	66	51	62	11	Yes
R-1201	E-9	B-Residential	66	51	60	9	No
R-1202	E-9	B-Residential	66	51	62	11	Yes
R-1203	E-9	B-Residential	66	51	62	11	Yes
R-1204	E-9	B-Residential	66	51	62	11	Yes
R-1205	E-9	B-Residential	66	51	63	12	Yes
R-1206	E-9	B-Residential	66	51	61	10	No
R-1207	E-9	B-Residential	66	51	62	11	Yes
R-1208	E-9	B-Residential	66	51	63	12	Yes

Traffic Noise Analysis Report Addendum – Preferred Alternative

Table 7. Segment E Traffic Noise Levels dB(A) Leq

Segment E Representative Receiver	Figure	NAC Category	NAC Level	Existing	Predicted 2050	Change (+/-)	Noise Impact (Yes/No)
R-1209	E-9	B-Residential	66	51	62	11	Yes
R-1210	E-9	B-Residential	66	51	63	12	Yes
R-1211	E-9	B-Residential	66	51	62	11	Yes
R-1212	E-9	B-Residential	66	51	63	12	Yes
R-1213	E-9	B-Residential	66	51	63	12	Yes
R-1214	E-9	B-Residential	66	51	65	14	Yes
R-1215	E-9	B-Residential	66	51	62	11	Yes
R-1216	E-9	B-Residential	66	51	65	14	Yes
R-1217	E-9	B-Residential	66	51	64	13	Yes
R-1218	E-9	B-Residential	66	51	63	12	Yes
R-1219	E-9	B-Residential	66	51	64	13	Yes
R-1220	E-9	B-Residential	66	51	62	11	Yes
R-1221	E-9	B-Residential	66	51	64	13	Yes
R-1222	E-9	B-Residential	66	51	64	13	Yes
R-1223	E-9	B-Residential	66	51	60	9	No
R-1224	E-9	B-Residential	66	51	63	12	Yes
R-1225	E-9	C-Mountain Bike Trail	66	51	68	17	Yes
R-1226	E-9	B-Residential	66	51	61	10	No
R-1227	E-8	C-Picnic areas	66	51	53	2	No
R-1228	E-9	B-Residential	66	51	62	11	Yes
R-1229	E-9	B-Residential	66	51	64	13	Yes
R-1230	E-9	B-Residential	66	51	63	12	Yes
R-1231	E-9	B-Residential	66	51	62	11	Yes
R-1232	E-9	B-Residential	66	51	62	11	Yes
R-1234	E-9	B-Residential	66	51	61	10	No
R-1235	E-9	B-Residential	66	51	61	10	No
R-1236	E-10	C-Mountain Bike Trail	66	51	67	16	Yes
R-1297	E-11	B-Residential	66	51	60	9	No
R-1298	E-11	B-Residential	66	51	59	8	No
R-1304	E-11	B-Residential	66	51	58	7	No
R-1322	E-11	B-Residential	66	51	59	8	No
R-1323	E-11	B-Residential	66	51	58	7	No
R-1329	E-11	B-Residential	66	51	58	7	No
R-1330	E-11	B-Residential	66	51	59	8	No
R-1335	E-11	B-Residential	66	51	58	7	No
R-1336	E-11	B-Residential	66	51	57	6	No
R-1337	E-11	B-Residential	66	51	58	7	No

Traffic Noise Analysis Report Addendum – Preferred Alternative

Table 7. Segment E Traffic Noise Levels dB(A) Leq

Segment E Representative Receiver	Figure	NAC Category	NAC Level	Existing	Predicted 2050	Change (+/-)	Noise Impact (Yes/No)
R-1338	E-11	B-Residential	66	51	59	8	No
R-1339	E-11	B-Residential	66	51	60	9	No
R-1342	E-11	B-Residential	66	51	57	6	No
R-1343	E-11	B-Residential	66	51	58	7	No
R-1344	E-11	B-Residential	66	51	57	6	No
R-1345	E-11	B-Residential	66	51	61	10	No
R-1347	E-11	B-Residential	66	51	61	10	No
R-1348	E-11	B-Residential	66	51	57	6	No
R-1350	E-11	B-Residential	66	51	61	10	No
R-1351	E-11	B-Residential	66	51	60	9	No
R-1353	E-11	B-Residential	66	51	60	9	No
R-1355	E-11	B-Residential	66	51	60	9	No
R-1357	E-11	B-Residential	66	51	60	9	No
R-1359	E-11	B-Residential	66	51	60	9	No
R-1361	E-11	B-Residential	66	51	59	8	No
R-1363	E-11	B-Residential	66	51	59	8	No
R-1365	E-11	B-Residential	66	51	58	7	No
R-1370	E-11	B-Residential	66	51	54	3	No
R-1371	E-11	B-Residential	66	51	55	4	No
R-1374	E-14	B-Residential	66	51	65	14	Yes
R-2144	E-15	B-Residential	66	66	71	5	Yes
R-2145	E-10	B-Residential	66	51	61	10	No
R-2146	E-10	B-Residential	66	51	61	10	No
R-2147	E-10	B-Residential	66	51	67	16	Yes
R-2148	E-10	B-Residential	66	51	67	16	Yes
R-2149	E-10	B-Residential	66	51	60	9	No
R-2150	E-10	B-Residential	66	51	59	8	No
R-2151	E-10	B-Residential	66	51	60	9	No
R-2152	E-10	B-Residential	66	51	66	15	Yes
R-2153	E-10	B-Residential	66	51	66	15	Yes
R-2154	E-10	B-Residential	66	51	59	8	No
R-2155	E-10	B-Residential	66	51	59	8	No
R-2156	E-10	B-Residential	66	51	67	16	Yes
R-2157	E-10	B-Residential	66	51	59	8	No
R-2158	E-10	B-Residential	66	51	59	8	No
R-2159	E-10	B-Residential	66	51	67	16	Yes
R-2160	E-10	B-Residential	66	51	60	9	No
R-2161	E-10	B-Residential	66	51	59	8	No
R-2162	E-10	B-Residential	66	51	67	16	Yes

Traffic Noise Analysis Report Addendum – Preferred Alternative

Table 7. Segment E Traffic Noise Levels dB(A) Leq

Segment E Representative Receiver	Figure	NAC Category	NAC Level	Existing	Predicted 2050	Change (+/-)	Noise Impact (Yes/No)
R-2163	E-10	B-Residential	66	51	66	15	Yes
R-2164	E-10	B-Residential	66	51	66	15	Yes
R-2165	E-10	B-Residential	66	51	66	15	Yes
R-2166	E-10	B-Residential	66	51	60	9	No
R-2167	E-10	B-Residential	66	51	60	9	No
R-2168	E-10	B-Residential	66	51	60	9	No
R-2169	E-10	B-Residential	66	51	61	10	No
R-2170	E-10	B-Residential	66	51	62	11	Yes
R-2171	E-10	B-Residential	66	51	66	15	Yes
R-2172	E-10	B-Residential	66	51	62	11	Yes
R-2173	E-10	B-Residential	66	51	66	15	Yes
R-2174	E-10	B-Residential	66	51	66	15	Yes
R-2175	E-10	B-Residential	66	51	66	15	Yes
R-2176	E-10	B-Residential	66	51	66	15	Yes
R-2177	E-10	B-Residential	66	51	66	15	Yes
R-2178	E-10	B-Residential	66	51	62	11	Yes
R-2179	E-10	B-Residential	66	51	63	12	Yes
R-2180	E-10	B-Residential	66	51	62	11	Yes
R-2181	E-10	B-Residential	66	51	63	12	Yes
R-2182	E-10	B-Residential	66	51	62	11	Yes
R-2183	E-10	B-Residential	66	51	63	12	Yes
R-2184	E-10	B-Residential	66	51	62	11	Yes
R-2185	E-10	B-Residential	66	51	63	12	Yes
R-2186	E-10	B-Residential	66	51	62	11	Yes
R-2187	E-10	B-Residential	66	51	63	12	Yes
R-2188	E-10	B-Residential	66	51	70	19	Yes
R-2189	E-10	B-Residential	66	51	62	11	Yes
R-2190	E-10	B-Residential	66	51	63	12	Yes
R-2191	E-10	B-Residential	66	51	69	18	Yes
R-2192	E-10	B-Residential	66	51	62	11	Yes
R-2193	E-10	B-Residential	66	51	62	11	Yes
R-2194	E-10	B-Residential	66	51	70	19	Yes
R-2195	E-10	B-Residential	66	51	62	11	Yes
R-2196	E-10	B-Residential	66	51	63	12	Yes
R-2197	E-10	B-Residential	66	51	70	19	Yes
R-2198	E-10	B-Residential	66	51	70	19	Yes
R-2199	E-10	B-Residential	66	51	71	20	Yes
R-2200	E-10	B-Residential	66	51	71	20	Yes
R-2201	E-10	B-Residential	66	51	71	20	Yes

Traffic Noise Analysis Report Addendum – Preferred Alternative

Table 7. Segment E Traffic Noise Levels dB(A) Leq

Segment E Representative Receiver	Figure	NAC Category	NAC Level	Existing	Predicted 2050	Change (+/-)	Noise Impact (Yes/No)
R-2202	E-10	B-Residential	66	51	72	21	Yes
R-2203	E-10	B-Residential	66	51	60	9	No
R-2204	E-10	B-Residential	66	51	60	9	No
R-2205	E-10	B-Residential	66	51	61	10	No
R-2206	E-10	B-Residential	66	51	61	10	No
R-2207	E-10	B-Residential	66	51	62	11	Yes
R-2208	E-10	B-Residential	66	51	62	11	Yes
R-2209	E-10	B-Residential	66	51	64	13	Yes
R-2210	E-10	B-Residential	66	51	64	13	Yes
R-2211	E-10	B-Residential	66	51	66	15	Yes
R-2212	E-10	B-Residential	66	51	66	15	Yes
R-2213	E-10	B-Residential	66	51	69	18	Yes
R-2214	E-10	B-Residential	66	51	68	17	Yes
R-2215	E-10	B-Residential	66	51	70	19	Yes
R-2216	E-10	B-Residential	66	51	72	21	Yes
R-2217	E-10	B-Residential	66	51	59	8	No
R-2218	E-10	B-Residential	66	51	60	9	No
R-2219	E-10	B-Residential	66	51	61	10	No
R-2220	E-10	B-Residential	66	51	62	11	Yes
R-2221	E-12	B-Residential	66	51	64	13	Yes
R-2222	E-12	B-Residential	66	51	65	14	Yes
R-2223	E-12	B-Residential	66	51	68	17	Yes
R-2224	E-12	B-Residential	66	51	71	20	Yes
R-2225	E-12	B-Residential	66	51	60	9	No
R-2226	E-12	B-Residential	66	51	61	10	No
R-2227	E-12	B-Residential	66	51	63	12	Yes
R-2228	E-12	B-Residential	66	51	65	14	Yes
R-2229	E-12	B-Residential	66	51	67	16	Yes
R-2230	E-12	B-Residential	66	51	71	20	Yes
R-2231	E-12	B-Residential	66	51	60	9	No
R-2232	E-12	B-Residential	66	51	61	10	No
R-2233	E-12	B-Residential	66	51	62	11	Yes
R-2234	E-12	B-Residential	66	51	64	13	Yes
R-2235	E-12	B-Residential	66	51	66	15	Yes
R-2236	E-12	B-Residential	66	51	68	17	Yes
R-2237	E-12	B-Residential	66	51	71	20	Yes
R-2238	E-12	B-Residential	66	51	60	9	No
R-2239	E-12	B-Residential	66	51	63	12	Yes
R-2240	E-12	B-Residential	66	51	65	14	Yes

Traffic Noise Analysis Report Addendum – Preferred Alternative

Table 7. Segment E Traffic Noise Levels dB(A) Leq

Segment E Representative Receiver	Figure	NAC Category	NAC Level	Existing	Predicted 2050	Change (+/-)	Noise Impact (Yes/No)
R-2241	E-12	B-Residential	66	51	67	16	Yes
R-2242	E-12	B-Residential	66	51	68	17	Yes
R-2243	E-12	B-Residential	66	51	70	19	Yes
R-2244	E-12	B-Residential	66	51	62	11	Yes
R-2245	E-12	B-Residential	66	51	62	11	Yes
R-2246	E-12	B-Residential	66	51	63	12	Yes
R-2247	E-12	B-Residential	66	51	63	12	Yes
R-2248	E-12	B-Residential	66	51	64	13	Yes
R-2249	E-12	B-Residential	66	51	65	14	Yes
R-2250	E-12	B-Residential	66	51	65	14	Yes
R-2251	E-12	B-Residential	66	51	66	15	Yes
R-2252	E-12	B-Residential	66	51	66	15	Yes
R-2253	E-12	B-Residential	66	51	68	17	Yes
R-2254	E-12	B-Residential	66	51	67	16	Yes
R-2255	E-12	B-Residential	66	51	69	18	Yes
R-2256	E-12	B-Residential	66	51	69	18	Yes
R-2258	E-12	B-Residential	66	51	71	20	Yes
R-2259	E-12	B-Residential	66	51	66	15	Yes
R-2260	E-12	B-Residential	66	51	65	14	Yes
R-2261	E-12	B-Residential	66	51	65	14	Yes
R-2262	E-12	B-Residential	66	51	72	21	Yes
R-2263	E-12	B-Residential	66	51	65	14	Yes
R-2264	E-12	B-Residential	66	51	65	14	Yes
R-2265	E-12	B-Residential	66	51	64	13	Yes
R-2266	E-12	B-Residential	66	51	65	14	Yes
R-2267	E-12	B-Residential	66	51	63	12	Yes
R-2269	E-12	B-Residential	66	51	64	13	Yes
R-2270	E-12	B-Residential	66	51	63	12	Yes
R-2271	E-12	B-Residential	66	51	63	12	Yes
R-2272	E-12	B-Residential	66	51	71	20	Yes
R-2273	E-12	B-Residential	66	51	71	20	Yes
R-2274	E-12	B-Residential	66	51	71	20	Yes
R-2275	E-12	B-Residential	66	51	71	20	Yes
R-2276	E-12	B-Residential	66	51	71	20	Yes
R-2277	E-12	B-Residential	66	51	70	19	Yes
R-2278	E-12	B-Residential	66	51	69	18	Yes
R-2279	E-12	B-Residential	66	51	68	17	Yes
R-2280	E-12	B-Residential	66	51	67	16	Yes
R-2281	E-12	B-Residential	66	51	66	15	Yes

Traffic Noise Analysis Report Addendum – Preferred Alternative

Table 7. Segment E Traffic Noise Levels dB(A) Leq

Segment E Representative Receiver	Figure	NAC Category	NAC Level	Existing	Predicted 2050	Change (+/-)	Noise Impact (Yes/No)
R-2282	E-12	B-Residential	66	51	65	14	Yes
R-2283	E-12	B-Residential	66	51	64	13	Yes
R-2284	E-12	B-Residential	66	51	63	12	Yes
R-2285	E-11	B-Residential	66	51	63	12	Yes
R-2286	E-9	B-Residential	66	51	59	8	No
R-2287	E-9	B-Residential	66	51	57	6	No
R-2288	E-9	B-Residential	66	51	57	6	No
R-2289	E-9	B-Residential	66	51	57	6	No
R-2290	E-9	B-Residential	66	51	57	6	No
R-2291	E-9	B-Residential	66	51	57	6	No
R-2292	E-9	B-Residential	66	51	57	6	No
R-2293	E-9	B-Residential	66	51	57	6	No
R-2294	E-9	B-Residential	66	51	57	6	No
R-2295	E-9	B-Residential	66	51	58	7	No
R-2296	E-9	B-Residential	66	51	58	7	No
R-2297	E-9	B-Residential	66	51	58	7	No
R-2298	E-9	B-Residential	66	51	59	8	No
R-2299	E-9	B-Residential	66	51	59	8	No
R-2300	E-9	B-Residential	66	51	59	8	No
R-2301	E-9	B-Residential	66	51	60	9	No
R-2302	E-9	B-Residential	66	51	60	9	No
R-2303	E-9	B-Residential	66	51	59	8	No
R-2304	E-9	B-Residential	66	51	57	6	No
R-2305	E-9	B-Residential	66	51	57	6	No
R-2306	E-9	B-Residential	66	51	57	6	No
R-2307	E-9	B-Residential	66	51	56	5	No
R-2308	E-9	B-Residential	66	51	56	5	No
R-2309	E-9	B-Residential	66	51	56	5	No
R-2310	E-9	B-Residential	66	51	56	5	No
R-2311	E-9	B-Residential	66	51	57	6	No
R-2312	E-9	B-Residential	66	51	57	6	No
R-2313	E-9	B-Residential	66	51	58	7	No
R-2314	E-9	B-Residential	66	51	60	9	No
R-2315	E-9	B-Residential	66	51	58	7	No
R-2316	E-9	B-Residential	66	51	58	7	No
R-2317	E-9	B-Residential	66	51	57	6	No
R-2496	E-13	B-Residential	66	51	70	19	Yes
R-2497	E-13	B-Residential	66	51	68	17	Yes
R-2498	E-13	B-Residential	66	51	70	19	Yes

Traffic Noise Analysis Report Addendum – Preferred Alternative

Table 7. Segment E Traffic Noise Levels dB(A) Leq

Segment E Representative Receiver	Figure	NAC Category	NAC Level	Existing	Predicted 2050	Change (+/-)	Noise Impact (Yes/No)
R-2499	E-13	B-Residential	66	51	70	19	Yes
R-2500	E-13	B-Residential	66	51	70	19	Yes
R-2501	E-13	B-Residential	66	51	68	17	Yes
R-2502	E-13	B-Residential	66	51	70	19	Yes
R-2503	E-13	B-Residential	66	51	70	19	Yes
R-2504	E-13	B-Residential	66	51	68	17	Yes
R-2505	E-13	B-Residential	66	51	68	17	Yes
R-2506	E-14	B-Residential	66	51	71	20	Yes
R-2507	E-14	B-Residential	66	51	71	20	Yes
R-2508	E-14	B-Residential	66	51	68	17	Yes
R-2509	E-14	B-Residential	66	51	70	19	Yes
R-2510	E-14	B-Residential	66	51	67	16	Yes
R-2511	E-14	B-Residential	66	51	69	18	Yes
R-2512	E-14	B-Residential	66	51	68	17	Yes
R-2513	E-14	B-Residential	66	51	68	17	Yes
R-2514	E-14	B-Residential	66	51	70	19	Yes
R-2515	E-14	B-Residential	66	51	70	19	Yes
R-2516	E-14	B-Residential	66	51	70	19	Yes
R-2517	E-14	B-Residential	66	51	70	19	Yes
R-2518	E-14	B-Residential	66	51	69	18	Yes
R-2519	E-14	B-Residential	66	51	69	18	Yes
R-2520	E-14	B-Residential	66	51	71	20	Yes
R-2521	E-14	B-Residential	66	51	71	20	Yes
R-2522	E-14	B-Residential	66	51	67	16	Yes
R-2523	E-14	B-Residential	66	51	70	19	Yes
R-2524	E-14	B-Residential	66	51	68	17	Yes
R-2525	E-14	B-Residential	66	51	69	18	Yes
R-2526	E-14	B-Residential	66	51	70	19	Yes
R-2527	E-14	B-Residential	66	51	71	20	Yes
R-2528	E-14	B-Residential	66	51	69	18	Yes
R-2529	E-14	B-Residential	66	51	70	19	Yes
R-2530	E-14	B-Residential	66	51	68	17	Yes
R-2531	E-14	B-Residential	66	51	71	20	Yes
R-2532	E-14	B-Residential	66	51	70	19	Yes
R-2533	E-14	B-Residential	66	51	67	16	Yes
R-2534	E-14	B-Residential	66	51	70	19	Yes
R-2535	E-14	B-Residential	66	51	69	18	Yes
R-2536	E-14	B-Residential	66	51	69	18	Yes
R-2537	E-14	B-Residential	66	51	67	16	Yes

Traffic Noise Analysis Report Addendum – Preferred Alternative

Table 7. Segment E Traffic Noise Levels dB(A) Leq

Segment E Representative Receiver	Figure	NAC Category	NAC Level	Existing	Predicted 2050	Change (+/-)	Noise Impact (Yes/No)
R-2538	E-14	B-Residential	66	51	68	17	Yes
R-2539	E-14	B-Residential	66	51	68	17	Yes
R-2540	E-14	B-Residential	66	51	65	14	Yes
R-2541	E-14	B-Residential	66	51	66	15	Yes
R-2542	E-14	B-Residential	66	51	66	15	Yes
R-2543	E-14	B-Residential	66	51	66	15	Yes
R-2544	E-14	B-Residential	66	51	66	15	Yes
R-2545	E-14	B-Residential	66	51	66	15	Yes
R-2546	E-14	B-Residential	66	51	66	15	Yes
R-2547	E-14	B-Residential	66	51	66	15	Yes
R-2548	E-14	B-Residential	66	51	66	15	Yes
R-2549	E-14	B-Residential	66	51	66	15	Yes
R-2550	E-14	B-Residential	66	51	66	15	Yes
R-2551	E-14	B-Residential	66	51	67	16	Yes
R-2552	E-14	B-Residential	66	51	66	15	Yes
R-2553	E-14	B-Residential	66	51	67	16	Yes
R-2554	E-14	B-Residential	66	51	67	16	Yes
R-2555	E-14	B-Residential	66	51	67	16	Yes
R-2556	E-14	B-Residential	66	51	67	16	Yes
R-2557	E-14	B-Residential	66	51	67	16	Yes
R-2558	E-14	B-Residential	66	51	67	16	Yes
R-2559	E-14	B-Residential	66	51	67	16	Yes
R-2560	E-14	B-Residential	66	51	67	16	Yes
R-2561	E-14	B-Residential	66	51	67	16	Yes
R-2562	E-14	B-Residential	66	51	67	16	Yes
R-2563	E-14	B-Residential	66	51	67	16	Yes
R-2564	E-14	B-Residential	66	51	68	17	Yes
R-2565	E-14	B-Residential	66	51	67	16	Yes
R-2566	E-14	B-Residential	66	51	67	16	Yes
R-2567	E-14	B-Residential	66	51	67	16	Yes
R-2568	E-14	B-Residential	66	51	67	16	Yes
R-2569	E-14	B-Residential	66	51	67	16	Yes
R-2570	E-14	B-Residential	66	51	67	16	Yes
R-2571	E-14	B-Residential	66	51	67	16	Yes
R-2572	E-14	B-Residential	66	51	68	17	Yes
R-2573	E-14	B-Residential	66	51	67	16	Yes
R-2574	E-14	B-Residential	66	51	67	16	Yes
R-2575	E-14	B-Residential	66	51	67	16	Yes
R-2576	E-14	B-Residential	66	51	67	16	Yes

Traffic Noise Analysis Report Addendum – Preferred Alternative

Table 7. Segment E Traffic Noise Levels dB(A) Leq

Segment E Representative Receiver	Figure	NAC Category	NAC Level	Existing	Predicted 2050	Change (+/-)	Noise Impact (Yes/No)
R-2577	E-14	B-Residential	66	51	67	16	Yes
R-2578	E-14	B-Residential	66	51	67	16	Yes
R-2579	E-14	B-Residential	66	51	67	16	Yes
R-2580	E-14	B-Residential	66	51	67	16	Yes
R-2581	E-14	B-Residential	66	51	67	16	Yes
R-2582	E-14	B-Residential	66	51	67	16	Yes
R-2583	E-14	B-Residential	66	51	66	15	Yes
R-2584	E-14	B-Residential	66	51	67	16	Yes
R-2585	E-14	B-Residential	66	51	67	16	Yes
R-2586	E-14	B-Residential	66	51	67	16	Yes
R-2587	E-14	B-Residential	66	51	66	15	Yes
R-2588	E-14	B-Residential	66	51	66	15	Yes
R-2589	E-14	B-Residential	66	51	66	15	Yes
R-2590	E-14	B-Residential	66	51	66	15	Yes
R-2591	E-14	B-Residential	66	51	64	13	Yes
R-2592	E-14	B-Residential	66	51	66	15	Yes
R-2593	E-14	B-Residential	66	51	65	14	Yes
R-2594	E-14	B-Residential	66	51	66	15	Yes
R-2595	E-14	B-Residential	66	51	65	14	Yes
R-2596	E-14	B-Residential	66	51	65	14	Yes
R-2597	E-14	B-Residential	66	51	65	14	Yes
R-2598	E-14	B-Residential	66	51	64	13	Yes
R-2599	E-14	B-Residential	66	51	64	13	Yes
R-2600	E-14	B-Residential	66	51	66	15	Yes
R-2601	E-14	B-Residential	66	51	67	16	Yes
R-2602	E-14	B-Residential	66	51	67	16	Yes
R-2603	E-14	B-Residential	66	51	67	16	Yes
R-2604	E-14	B-Residential	66	51	67	16	Yes
R-2605	E-14	B-Residential	66	51	67	16	Yes
R-2606	E-14	B-Residential	66	51	67	16	Yes
R-2607	E-14	B-Residential	66	51	67	16	Yes
R-2608	E-14	B-Residential	66	51	67	16	Yes
R-2609	E-14	B-Residential	66	51	67	16	Yes
R-2610	E-14	B-Residential	66	51	67	16	Yes
R-2611	E-14	B-Residential	66	51	68	17	Yes
R-2612	E-14	B-Residential	66	51	67	16	Yes
R-2613	E-14	B-Residential	66	51	68	17	Yes
R-2614	E-14	B-Residential	66	51	68	17	Yes
R-2615	E-14	B-Residential	66	51	68	17	Yes

Traffic Noise Analysis Report Addendum – Preferred Alternative

Table 7. Segment E Traffic Noise Levels dB(A) Leq

Segment E Representative Receiver	Figure	NAC Category	NAC Level	Existing	Predicted 2050	Change (+/-)	Noise Impact (Yes/No)
R-2616	E-14	B-Residential	66	51	68	17	Yes
R-2617	E-14	B-Residential	66	51	68	17	Yes
R-2618	E-14	B-Residential	66	51	68	17	Yes
R-2619	E-14	B-Residential	66	51	68	17	Yes
R-2620	E-14	B-Residential	66	51	69	18	Yes
R-2621	E-14	B-Residential	66	51	69	18	Yes
R-2622	E-14	B-Residential	66	51	69	18	Yes
R-2623	E-14	B-Residential	66	51	69	18	Yes
R-2624	E-14	B-Residential	66	51	69	18	Yes
R-2625	E-14	B-Residential	66	51	69	18	Yes
R-2626	E-14	B-Residential	66	51	70	19	Yes
R-2627	E-14	B-Residential	66	51	69	18	Yes
R-2628	E-14	B-Residential	66	51	69	18	Yes
R-2629	E-14	B-Residential	66	51	69	18	Yes
R-2630	E-14	B-Residential	66	51	69	18	Yes
R-2631	E-14	B-Residential	66	51	69	18	Yes
R-2632	E-14	B-Residential	66	51	69	18	Yes
R-2633	E-14	B-Residential	66	51	69	18	Yes
R-2634	E-14	B-Residential	66	51	69	18	Yes
R-2635	E-14	B-Residential	66	51	69	18	Yes
R-2636	E-14	B-Residential	66	51	69	18	Yes
R-2637	E-14	B-Residential	66	51	69	18	Yes
R-2638	E-14	B-Residential	66	51	69	18	Yes
R-2639	E-14	B-Residential	66	51	69	18	Yes
R-2640	E-14	B-Residential	66	51	69	18	Yes
R-2641	E-14	B-Residential	66	51	69	18	Yes
R-2642	E-14	B-Residential	66	51	69	18	Yes
R-2643	E-14	B-Residential	66	51	69	18	Yes
R-2644	E-14	B-Residential	66	51	69	18	Yes
R-2645	E-14	B-Residential	66	51	68	17	Yes
R-2646	E-14	B-Residential	66	51	69	18	Yes
R-2647	E-14	B-Residential	66	51	68	17	Yes
R-2648	E-14	B-Residential	66	51	68	17	Yes
R-2649	E-14	B-Residential	66	51	68	17	Yes
R-2650	E-14	B-Residential	66	51	67	16	Yes
R-2651	E-14	B-Residential	66	51	66	15	Yes
R-2652	E-14	B-Residential	66	51	68	17	Yes
R-2653	E-14	B-Residential	66	51	67	16	Yes
R-2654	E-14	B-Residential	66	51	68	17	Yes

Traffic Noise Analysis Report Addendum – Preferred Alternative

Table 7. Segment E Traffic Noise Levels dB(A) Leq

Segment E Representative Receiver	Figure	NAC Category	NAC Level	Existing	Predicted 2050	Change (+/-)	Noise Impact (Yes/No)
R-2655	E-14	B-Residential	66	51	67	16	Yes
R-2656	E-14	B-Residential	66	51	67	16	Yes
R-2657	E-14	B-Residential	66	51	67	16	Yes
R-2658	E-14	B-Residential	66	51	66	15	Yes
R-2659	E-14	B-Residential	66	51	66	15	Yes
R-2660	E-14	B-Residential	66	51	67	16	Yes
R-2661	E-14	B-Residential	66	51	67	16	Yes
R-2662	E-14	B-Residential	66	51	68	17	Yes
R-2663	E-14	B-Residential	66	51	68	17	Yes
R-2664	E-14	B-Residential	66	51	68	17	Yes
R-2665	E-14	B-Residential	66	51	69	18	Yes
R-2666	E-14	B-Residential	66	51	71	20	Yes
R-2667	E-14	B-Residential	66	51	67	16	Yes
R-2668	E-14	B-Residential	66	51	67	16	Yes
R-2669	E-14	B-Residential	66	51	67	16	Yes
R-2670	E-14	B-Residential	66	51	67	16	Yes
R-2671	E-14	B-Residential	66	51	67	16	Yes
R-2672	E-14	B-Residential	66	51	71	20	Yes
R-2673	E-14	B-Residential	66	51	69	18	Yes
R-2674	E-14	B-Residential	66	51	68	17	Yes
R-2675	E-14	B-Residential	66	51	69	18	Yes
R-2676	E-12	B-Residential	66	51	58	7	No
R-2677	E-12	B-Residential	66	51	58	7	No
R-2680	E-11	B-Residential	66	51	67	16	Yes
R-2681	E-11	B-Residential	66	51	61	10	No
R-2682	E-13	B-Residential	66	51	62	11	Yes

Abbreviations: NAC, Noise Abatement Criteria; dB(A), A-weighted decibel; Leq, average/equivalent sound level.

As indicated in **Table 7**, the proposed project would result in a traffic noise impact at one or more representative receiver locations. Noise abatement measures were considered for each location with predicted noise impacts.

Abatement Analysis – Segment E

Feasible and Reasonable Barriers

Noise barriers would be feasible and reasonable for the following impacted receptors, and therefore, are proposed for incorporation into the project. **Table 8** summarizes the proposed noise barriers.

Traffic Noise Analysis Report Addendum – Preferred Alternative

Table 8. Segment E Proposed Noise Barriers

Barrier	Locations	Impacted Receptor Number (Type)	Number of Benefited Receptors	Length (feet)	Height (feet)	Total Barrier Area (ft ²)	Sq. Ft. / Benefited Receptor (ft ²)
E04	Erwin Park	R-1225 and R-1236 (Park)	2 (40 Dwelling Unit Equivalents)	2,481	17	42,177	1,054
E05	Erwin Farms*	R-1196 to R-1200, R-1202 to R-1205, R-1207 to R-1222, R-1224, R-1228 to R-1232, and R-2285 (Residential)	34	2,450	19	46,550	1,369
E08	New Development Horizons*	R-2147, R-2148, R-2152, R-2153, R-2156, R-2159, R-2162 to R-2165, R-2170 to R-2202, R-2207 to R-2216, R-2220 to R-2224, R-2227 to R-2230, R-2233 to R-2237, R-2239 to R-2256, R-2258 to R-2267, R-2269 to R-2284, R-2680, and R-2682 (Residential)	60	3,872	11	42,592	710

*Note: This development is either under construction or permitted for development. At the time the noise model was conducted, none of the receptors in the development were present.

Barrier E04: R-1225 and R-1236 (Figure E-9, Figure E-10, and Figure E-11) - These receivers represent a total of 40 (forty) equivalent dwelling units at Erwin Park along the Preferred Alternative. Based on preliminary calculations, a noise barrier 2,481 feet in length, 17 feet in height, and located along the proposed ROW would reduce noise levels by at least 5 dB(A) for 40 (forty) benefited receptors and meet the noise reduction design goal of 7 dB(A) for at least one of those receptors. With a total area of abatement of 42,177 square feet or 1,054 square feet per benefited receptor, the barrier would be cost reasonable. Therefore, Barrier E04 is considered acoustically feasible and cost effective.

Barrier E05: R-1196 to R-1200, R-1202 to R-1205, R-1207 to R-1222, R-1224, R-1228 to R-1232, and R-2285 (Figure E-10, and Figure E-11) - These receivers represent a total of 32 (thirty-two) impacted residences at the Erwin Farms neighborhood along the Preferred Alternative. Based on preliminary calculations, a noise barrier 2,450 feet in length, 19 feet in height, and located along the proposed ROW would reduce noise levels by at least 5 dB(A) for 34 (thirty-four) benefited receptors and meet the noise reduction design goal of 7 dB(A) for at least one of those receptors. With a total area of abatement of 46,550 square feet or 1,369 square feet per benefited receptor, the barrier would be cost reasonable. Therefore, Barrier E05 is considered acoustically feasible and cost effective.

Barrier E08: R-2147, R-2148, R-2152, R-2153, R-2156, R-2159, R-2162 to R-2165, R-2170 to R-2202, R-2207 to R-2216, R-2220 to R-2224, R-2227 to R-2230, R-2233 to R-2237, R-2239 to R-2256, R-2258 to R-2267, R-2269 to R-2284, R-2680, and R-2682 (Figure E-11, and Figure E-13) - These receivers represent a total of 113 (one hundred and thirteen) impacted residences at the new development at Horizons neighborhood along the Preferred Alternative. Based on preliminary calculations, a noise barrier

Traffic Noise Analysis Report Addendum – Preferred Alternative

3,872 feet in length, 11 feet in height, and located along the proposed ROW would reduce noise levels by at least 5 dB(A) for 60 (sixty) benefited receptors and meet the noise reduction design goal of 7 dB(A) for at least one of those receptors. With a total area of abatement of 42,592 square feet or 710 square feet per benefited receptor, the barrier would be cost reasonable. Therefore, Barrier E08 is considered acoustically feasible and cost effective.

Barriers Analyzed But Not Proposed

Noise barriers would not be feasible and reasonable for any of the following impacted receptors, and therefore, are not proposed for incorporation into the project:

R-1187, R-1188, R-1374, and R-2144- These receptors are separate, isolated residences, which are not associated with a neighborhood or subdivision. Because a noise abatement measure must potentially benefit a minimum of two impacted receptors, noise abatement for these locations is not feasible.

Barrier E03: R-1191 (Figure E-6, Figure E-7 and Figure E-8) - This receiver represents a total of 102 (one hundred and two) equivalent dwelling units at City Parkland along the Preferred Alternative. Based on preliminary calculations, a noise barrier 2,268 feet in length, 20 feet in height, and located along the proposed ROW would not be sufficient to achieve the minimum, feasible reduction of 5 dB(A) for a majority of impacted receptors or the noise reduction design goal of 7 dB(A).

Barrier E06: R-1178 and R-1181 to R-1184 (Figure E-4 and Figure E-5) – An existing barrier is located in front of the Heatherwood neighborhood, where noise impacts at the sides of the barrier occur at locations where the existing barrier cannot adequately address the increase in traffic noise under the build condition. While the existing neighborhood wall does provide some noise reduction, the existing wall does not wrap around the ends or sides of the barrier and therefore does not provide enough acoustical shielding to homes deeper into the neighborhood due to flanking.

These receivers represent a total of 5 (five) equivalent dwelling units in the Heatherwood neighborhood along the Preferred Alternative. Based on preliminary calculations, a noise barrier 1,897 feet in length, 20 feet in height, and located along the ROW would not be sufficient to achieve the minimum, feasible reduction of 5 dB(A) for a majority of impacted receptors or the noise reduction design goal of 7 dB(A).

Barrier E07: R-1170 and R-1175 (Figure E-4 and Figure E-5) – These receivers represent a total of 2 (two) equivalent dwelling units from STA 1635+20 to STA 1635+80 along the Preferred Alternative. Based on preliminary calculations, a noise barrier 284 feet in length, 20 feet in height, and located along the ROW would not be sufficient to achieve the minimum, feasible reduction of 5 dB(A) for a majority of impacted receptors or the noise reduction design goal of 7 dB(A).

Barrier E09: R-2496 to R-2675 (Figure E-13 and Figure E-14)– These receivers represent a total of 540 (five hundred and forty) equivalent dwelling units at the new development at Modera McKinney Ridge along the Preferred Alternative. Based on preliminary calculations, a noise barrier 1,786 feet in length, 20 feet in height, and located along the ROW would not be sufficient to achieve the minimum, feasible reduction of 5 dB(A) for a majority of impacted receptors or the noise reduction design goal of 7 dB(A).

Table 9 summarizes the number of receptors that exceed the NAC, proposed barriers, and benefited receivers for the Preferred Alternative.

Table 9. Summary of Results

Traffic Noise Analysis Report Addendum – Preferred Alternative

Statistics	Type of Receptor	Preferred Alternative		
		Segment A	Segment C	Segment E
Summary of Traffic Noise Impacts	Cat B	568	42	577
	Cat C	11	1	6
	Cat E	0	0	0
	Total:	579	43	583
Barriers Proposed	Total:	5 (Barrier A01, A07-2, A-10, A11, and A12)		3 (Barrier E04, E05, and E08)
Benefited Receivers	Cat B	223	0	94
	Cat C	0	0	2
	Cat E	0	0	0
	Total:	223	0	96

Statement of Likelihood

Any subsequent project design changes may require a reevaluation of this preliminary noise barrier proposal. The final decision to construct the proposed noise barrier will not be made until completion of the project design, utility evaluation, and polling of all benefited and adjacent property owners and residents.

Noise Contours for Land Use Planning

To avoid noise impacts that may result from future development of properties adjacent to the project, local officials responsible for land use control programs must ensure, to the maximum extent possible, that no new activities are planned or constructed along or within the following (Table 10) predicted (2050) noise impact contours.

Table 10. Noise Contours for Land Use Planning

Segment	Land Use	Impact Contour	Distance from Right of Way
A	NAC categories B & C	66 dB(A)	≈ 300 feet
	NAC category E	71 dB(A)	≈ 114 feet
C	NAC categories B & C	66 dB(A)	≈ 425 feet
	NAC category E	71 dB(A)	≈ 124 feet
E	NAC categories B & C	66 dB(A)	≈ 333 feet
	NAC category E	71 dB(A)	≈ 124 feet

Source: Guidelines for Analysis and Abatement of Roadway Traffic Noise (TxDOT 2019)

Construction Noise

Traffic Noise Analysis Report Addendum – Preferred Alternative

Noise associated with the construction of the project is difficult to predict. Heavy machinery, the major source of noise in construction, is constantly moving in unpredictable patterns. However, construction normally occurs during daylight hours when occasional loud noises are more tolerable. None of the receptors is expected to be exposed to construction noise for a long duration; therefore, any extended disruption of normal activities is not expected. Provisions will be included in the plans and specifications that require the contractor to make every reasonable effort to minimize construction noise through abatement measures such as work-hour controls and proper maintenance of muffler systems.

Local Official Notification and Date of Public Knowledge Statement

A copy of this traffic noise analysis will be available to local officials. On the date of the environmental decision for this project (Date of Public Knowledge), FHWA and TxDOT are no longer responsible for providing noise abatement for new development adjacent to the project.

List of Attachments

Map figures

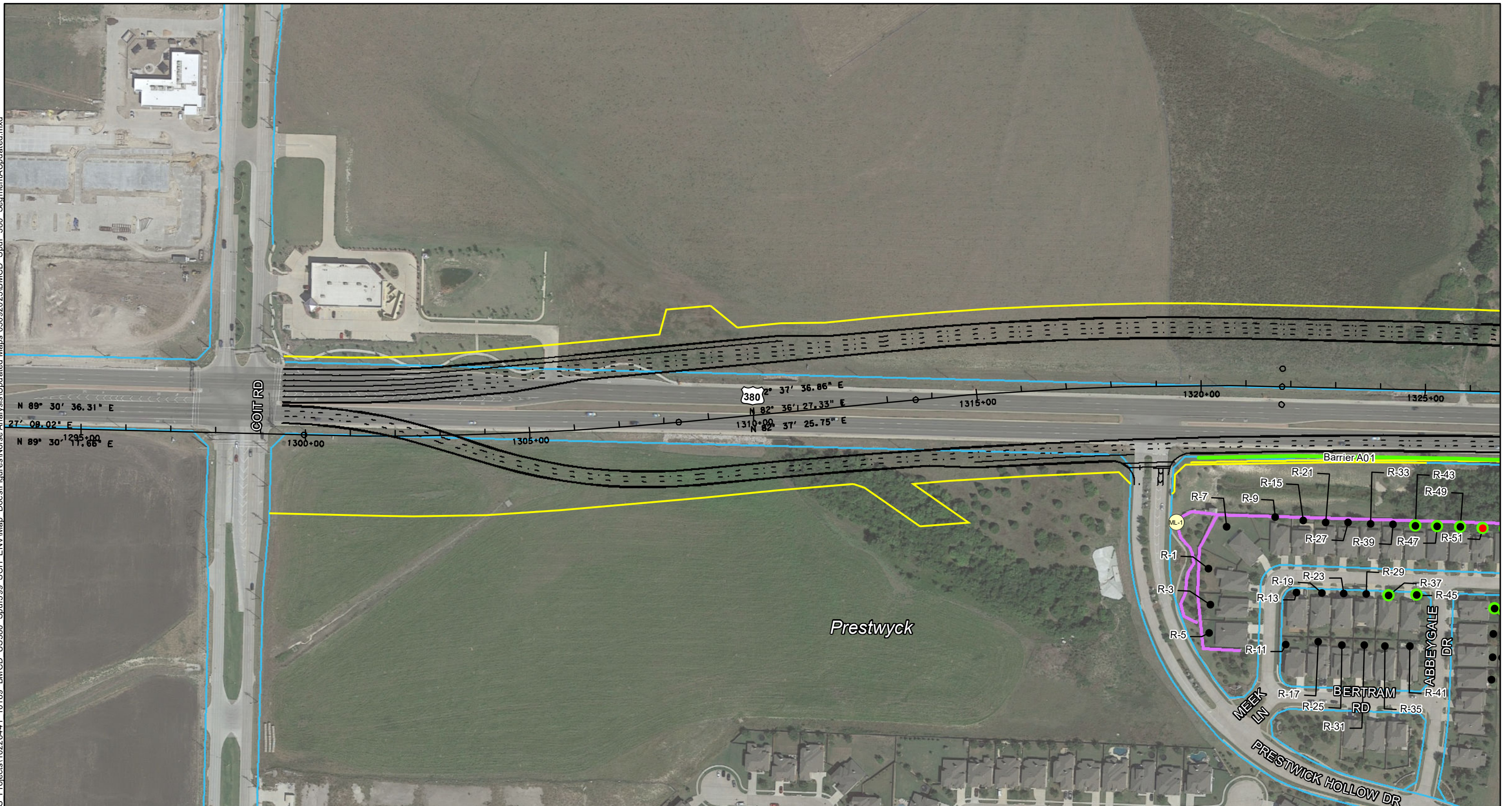
Traffic data

Existing Model Validation Study

Ambient Noise Measurement

Traffic Noise Analysis Report Addendum – Preferred Alternative

Attachment A – Map Figures



Legend

- PROPOSED BARRIER
- BARRIER ANALYZED BUT NOT PROPOSED
- IMPACTED RECEIVER
- NON-IMPACTED RECEIVER
- BENEFITED RECEIVER
- RESIDENTIAL DISPLACEMENT
- COMMERCIAL DISPLACEMENT
- EXISTING ROW
- PROPOSED IMPROVEMENTS
- PROPOSED ROW
- EXISTING NEIGHBORHOOD WALLS
- VALIDATION LOCATIONS
- AMBIENT MEASUREMENT SITES

NOISE IMPACTS AND RECEIVERS

US 380
SEGMENT A

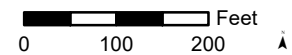
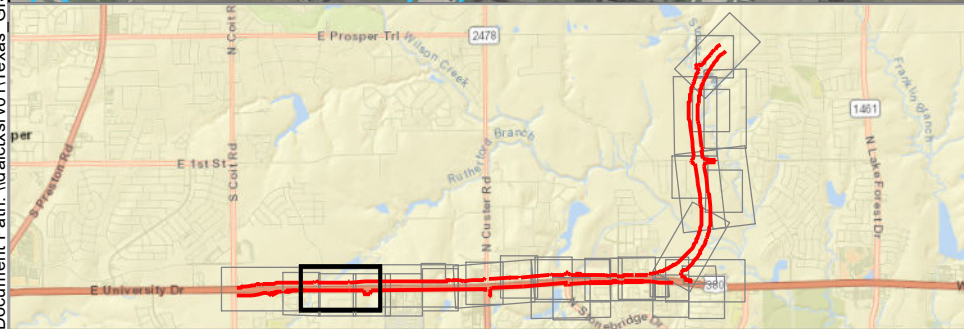
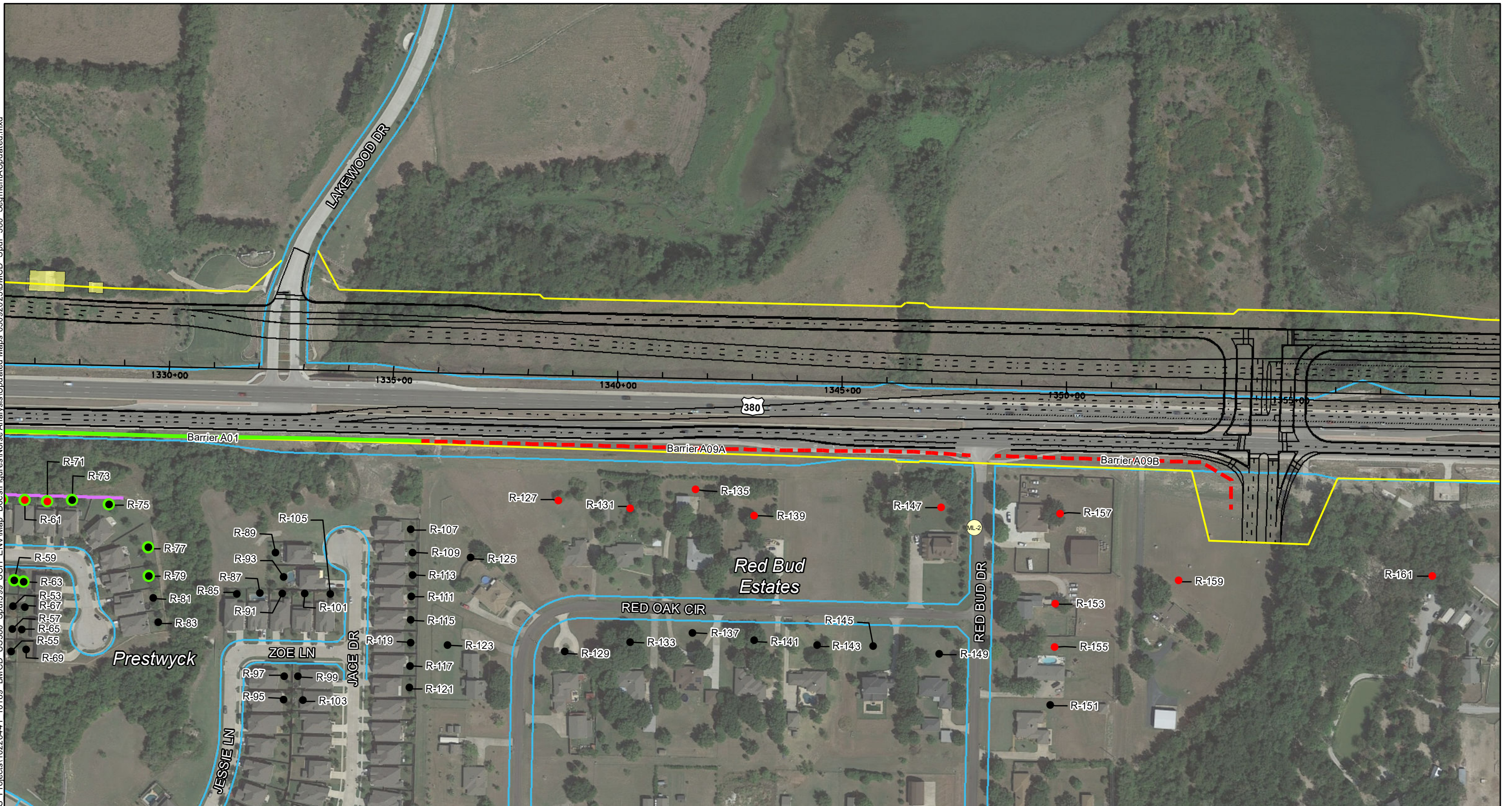


FIGURE A-1
JUNE 2023



Legend

- PROPOSED BARRIER
- - - BARRIER ANALYZED BUT NOT PROPOSED
- IMPACTED RECEIVER
- NON-IMPACTED RECEIVER
- BENEFITED RECEIVER
- RESIDENTIAL DISPLACEMENT
- COMMERCIAL DISPLACEMENT
- EXISTING ROW
- PROPOSED IMPROVEMENTS
- PROPOSED ROW
- EXISTING NEIGHBORHOOD WALLS
- VALIDATION LOCATIONS
- AMBIENT MEASUREMENT SITES

NOISE IMPACTS AND RECEIVERS

US 380
SEGMENT A

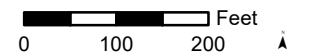
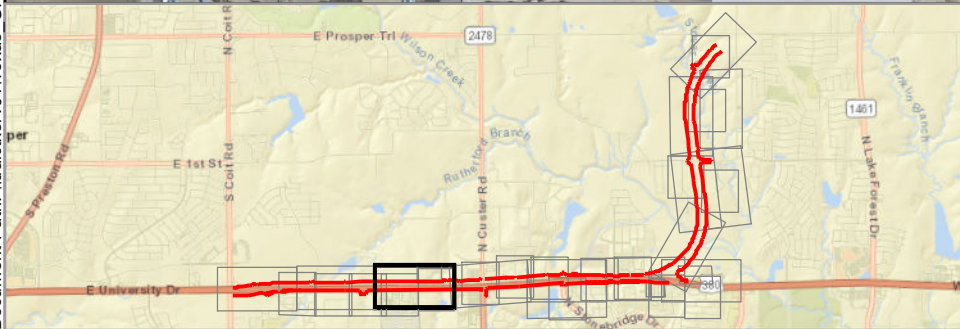


FIGURE A-2
JUNE 2023



Legend

- PROPOSED BARRIER
- - - BARRIER ANALYZED BUT NOT PROPOSED
- IMPACTED RECEIVER
- NON-IMPACTED RECEIVER
- BENEFITED RECEIVER
- RESIDENTIAL DISPLACEMENT
- COMMERCIAL DISPLACEMENT
- EXISTING ROW
- PROPOSED IMPROVEMENTS
- PROPOSED ROW
- EXISTING NEIGHBORHOOD WALLS
- VALIDATION LOCATIONS
- AMBIENT MEASUREMENT SITES

NOISE IMPACTS AND RECEIVERS

US 380
SEGMENT A

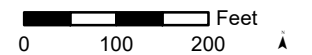
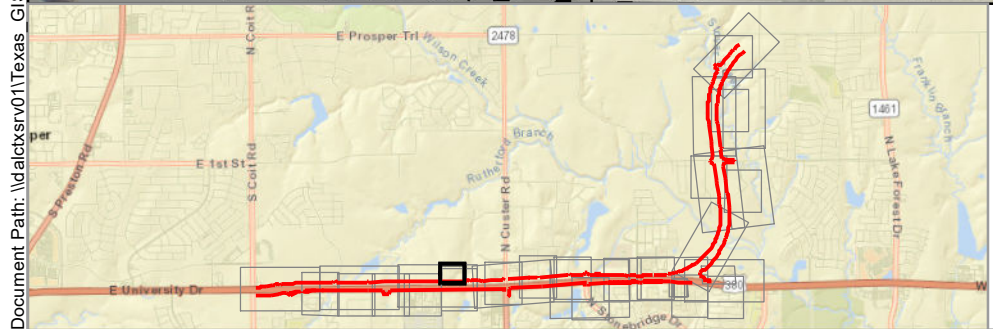
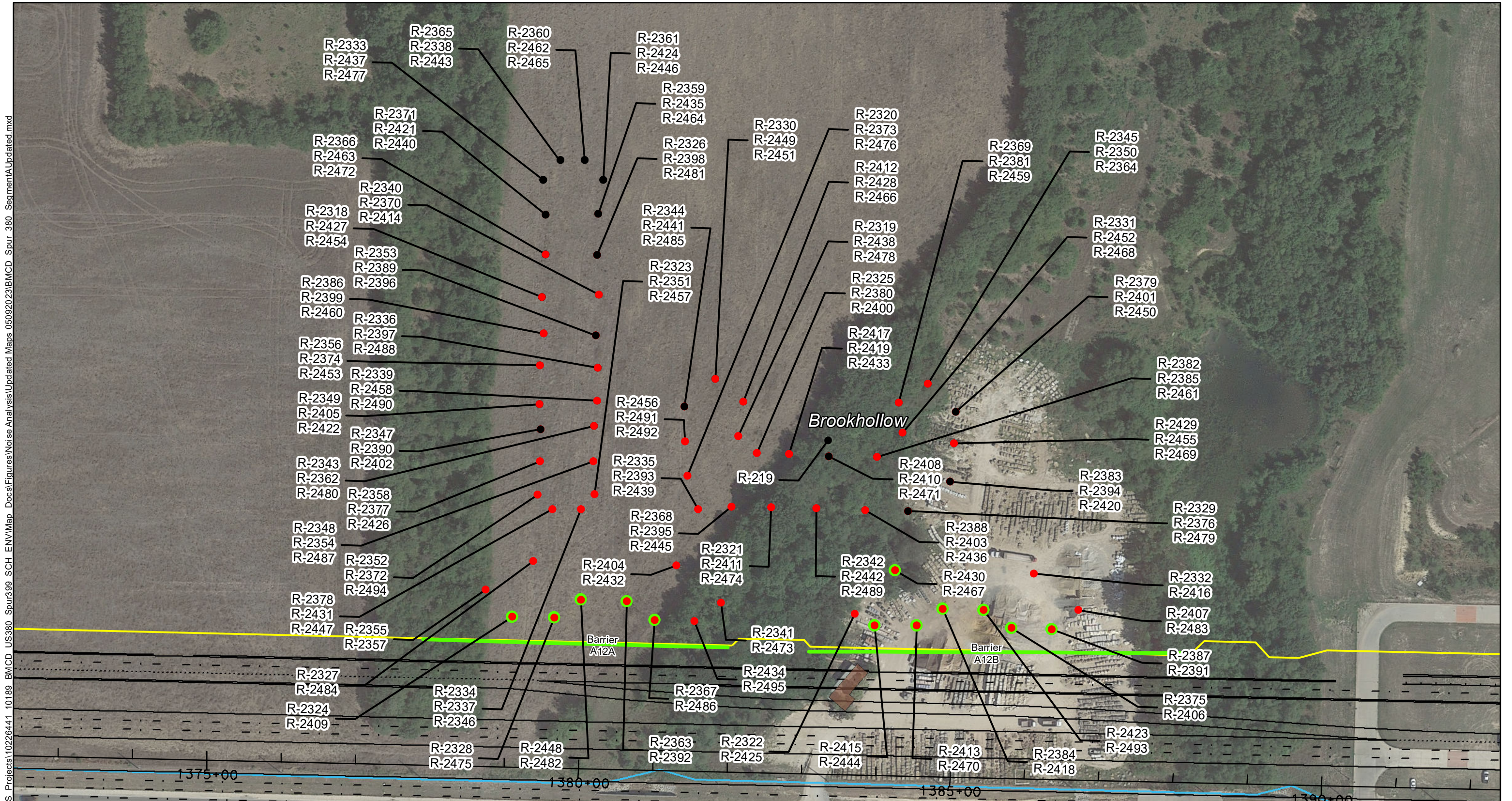


FIGURE A-3
JUNE 2023



Legend

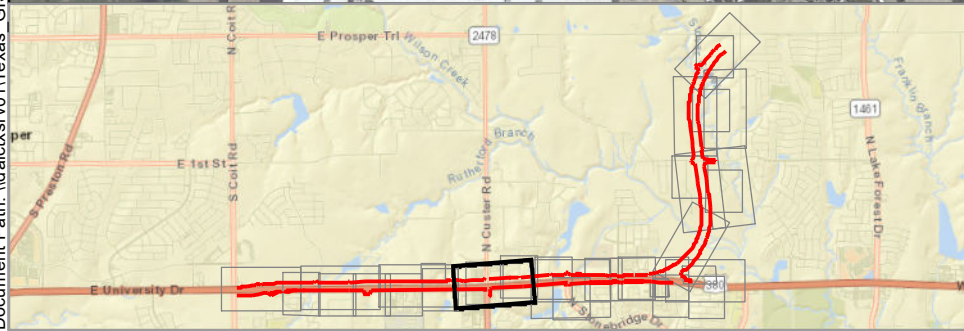
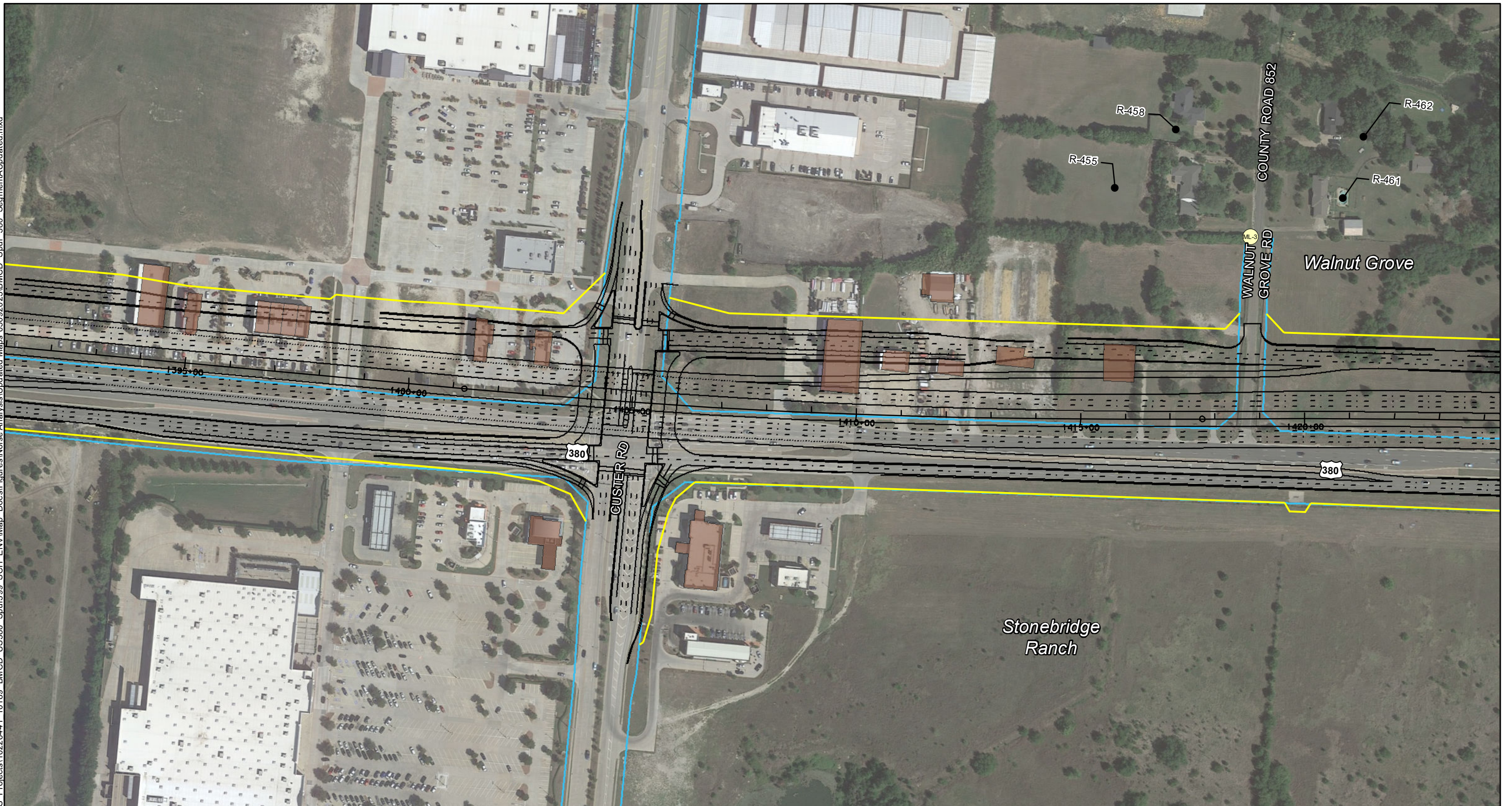
PROPOSED BARRIER	EXISTING ROW
BARRIER ANALYZED BUT NOT PROPOSED	PROPOSED IMPROVEMENTS
IMPACTED RECEIVER	PROPOSED ROW
NON-IMPACTED RECEIVER	EXISTING NEIGHBORHOOD WALLS
BENEFITED RECEIVER	VALIDATION LOCATIONS
RESIDENTIAL DISPLACEMENT	AMBIENT MEASUREMENT SITES
COMMERCIAL DISPLACEMENT	

NOISE IMPACTS AND RECEIVERS

US 380
SEGMENT A

0 60 120 Feet

FIGURE A-4
JUNE 2023



Legend

- PROPOSED BARRIER
- - - BARRIER ANALYZED BUT NOT PROPOSED
- IMPACTED RECEIVER
- NON-IMPACTED RECEIVER
- BENEFITED RECEIVER
- RESIDENTIAL DISPLACEMENT
- COMMERCIAL DISPLACEMENT
- EXISTING ROW
- PROPOSED IMPROVEMENTS
- PROPOSED ROW
- EXISTING NEIGHBORHOOD WALLS
- VALIDATION LOCATIONS
- AMBIENT MEASUREMENT SITES

NOISE IMPACTS AND RECEIVERS

US 380
SEGMENT A

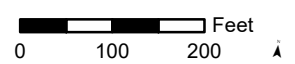
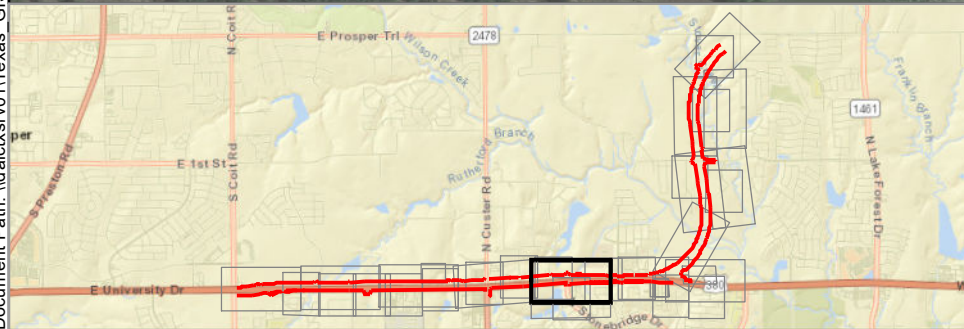
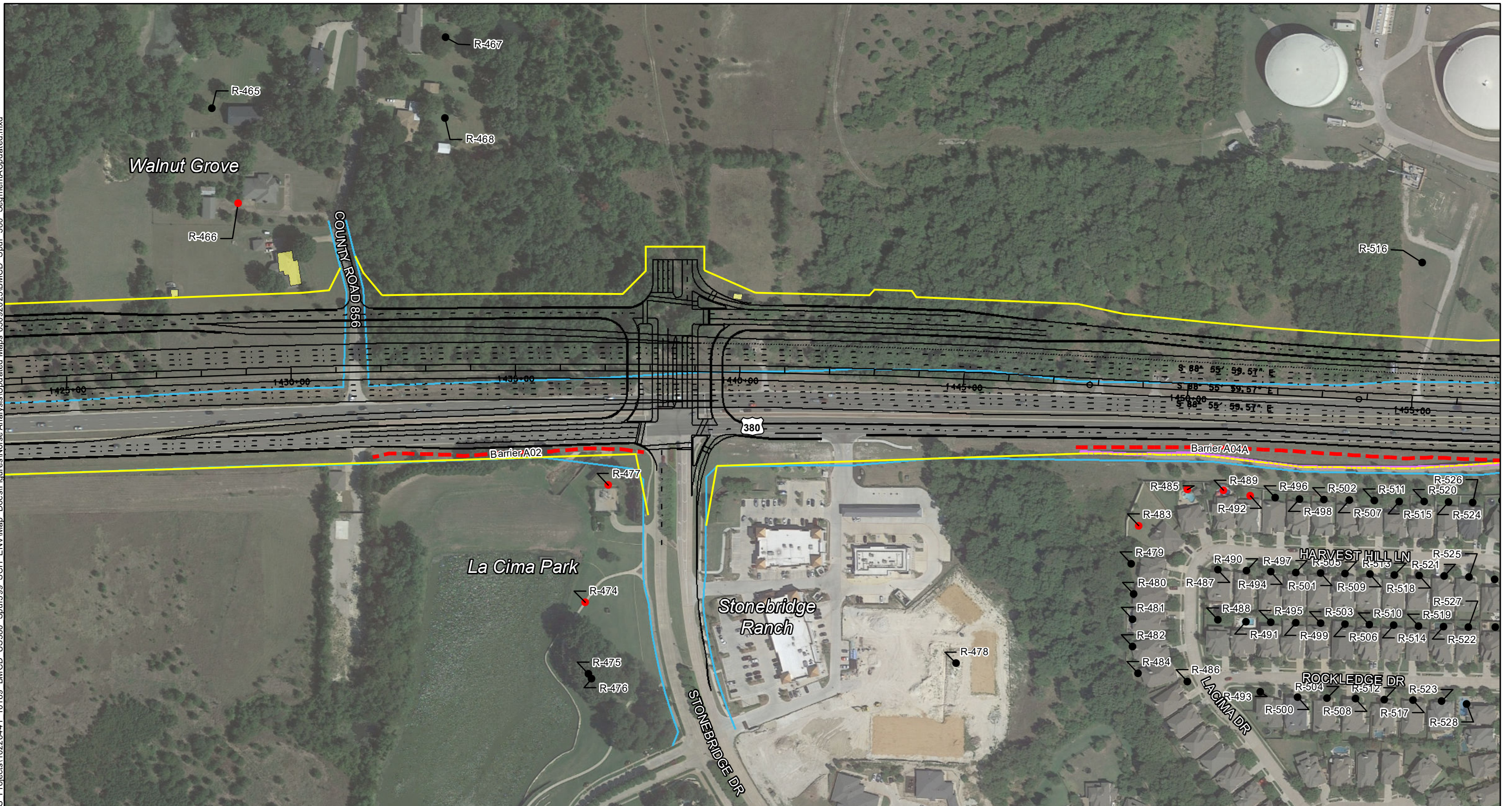


FIGURE A-5
JUNE 2023



Legend

- PROPOSED BARRIER
- - - BARRIER ANALYZED BUT NOT PROPOSED
- IMPACTED RECEIVER
- NON-IMPACTED RECEIVER
- BENEFITED RECEIVER
- RESIDENTIAL DISPLACEMENT
- COMMERCIAL DISPLACEMENT
- EXISTING ROW
- PROPOSED IMPROVEMENTS
- PROPOSED ROW
- EXISTING NEIGHBORHOOD WALLS
- VALIDATION LOCATIONS
- AMBIENT MEASUREMENT SITES

NOISE IMPACTS AND RECEIVERS

US 380
SEGMENT A

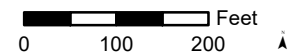
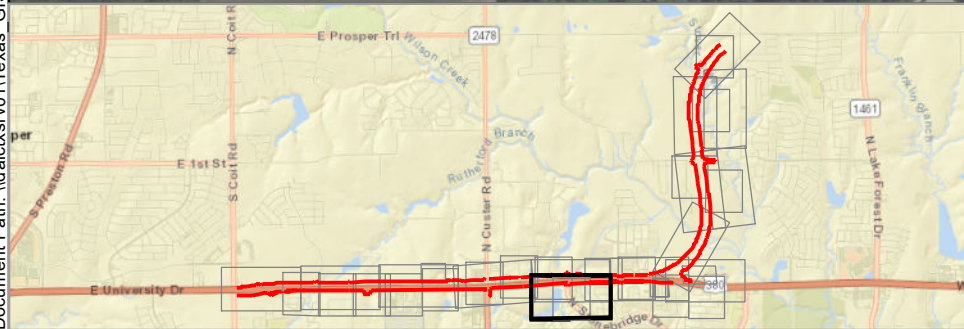
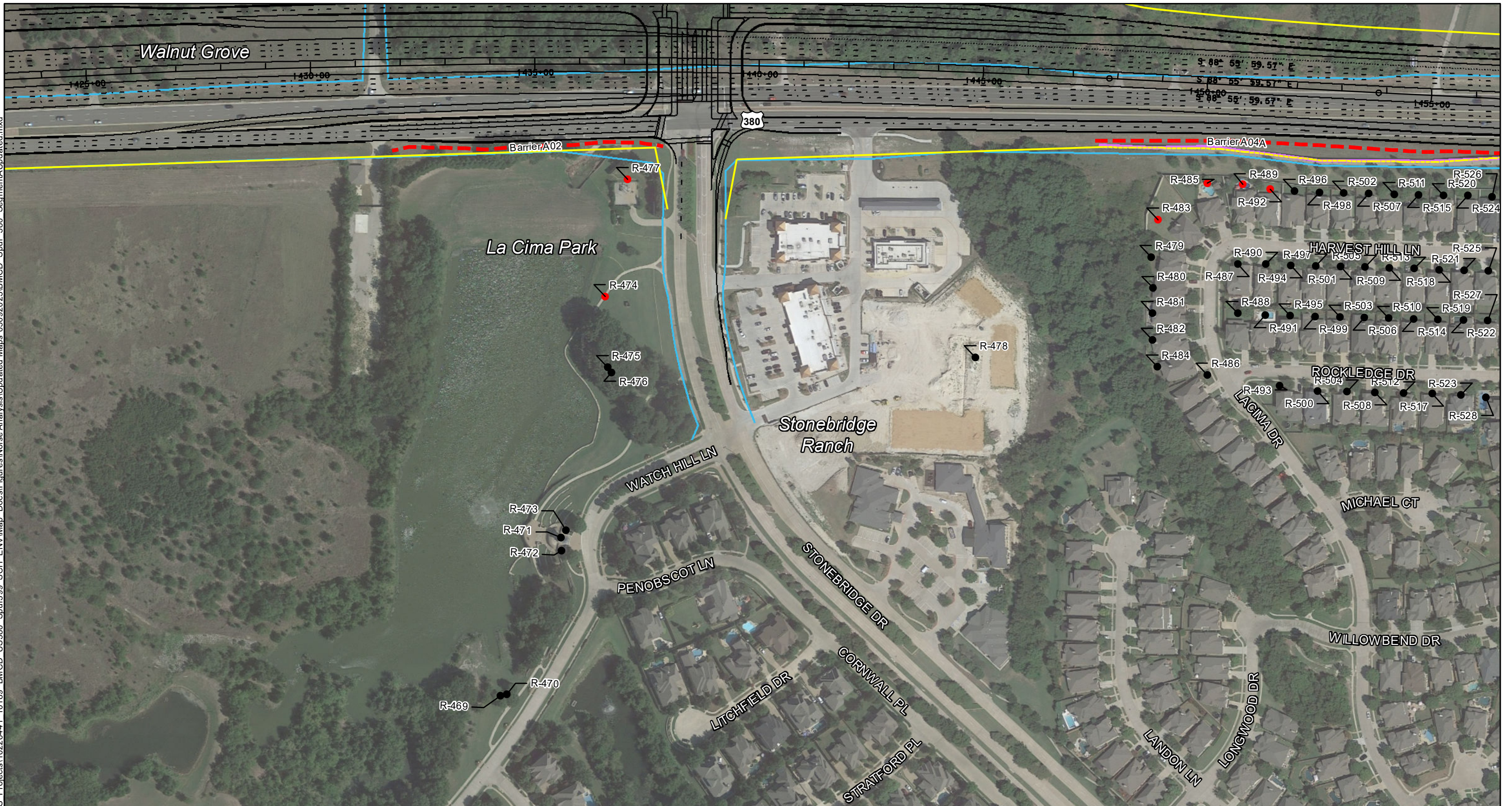


FIGURE A-6
JUNE 2023



Legend

- PROPOSED BARRIER
- - - BARRIER ANALYZED BUT NOT PROPOSED
- IMPACTED RECEIVER
- NON-IMPACTED RECEIVER
- BENEFITED RECEIVER
- RESIDENTIAL DISPLACEMENT
- COMMERCIAL DISPLACEMENT
- EXISTING ROW
- PROPOSED IMPROVEMENTS
- PROPOSED ROW
- EXISTING NEIGHBORHOOD WALLS
- VALIDATION LOCATIONS
- AMBIENT MEASUREMENT SITES

NOISE IMPACTS AND RECEIVERS

US 380
SEGMENT A

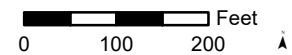
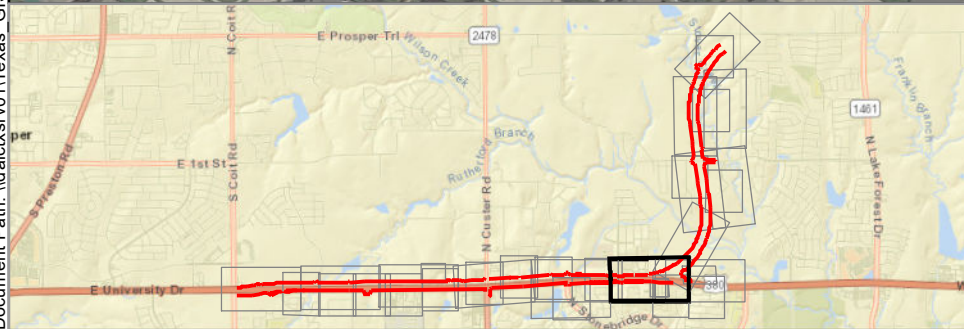
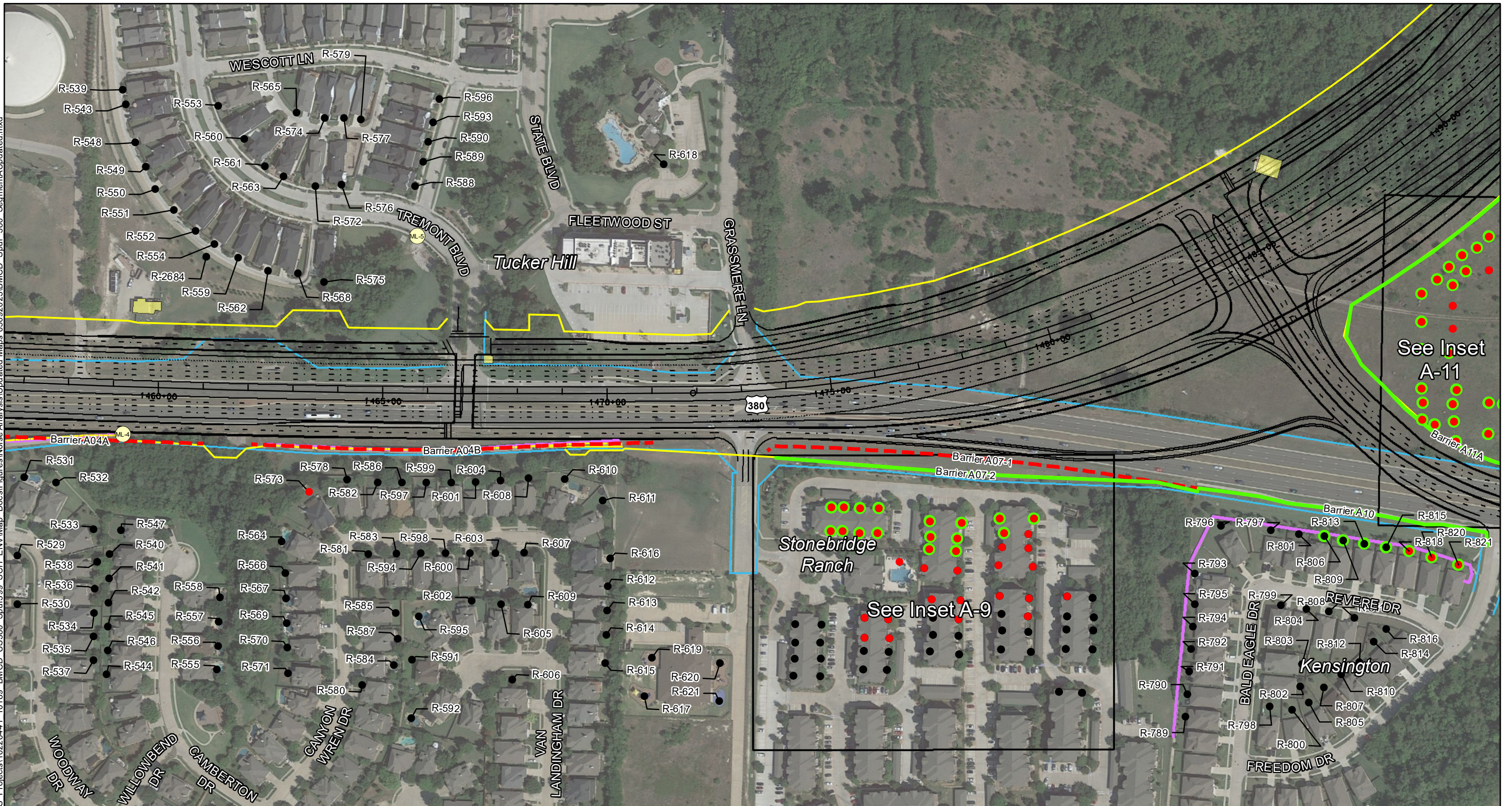


FIGURE A-7
JUNE 2023



Legend

- PROPOSED BARRIER
- - - BARRIER ANALYZED BUT NOT PROPOSED
- IMPACTED RECEIVER
- NON-IMPACTED RECEIVER
- BENEFITED RECEIVER
- RESIDENTIAL DISPLACEMENT
- COMMERCIAL DISPLACEMENT
- EXISTING ROW
- PROPOSED IMPROVEMENTS
- PROPOSED ROW
- EXISTING NEIGHBORHOOD WALLS
- VALIDATION LOCATIONS
- AMBIENT MEASUREMENT SITES

NOISE IMPACTS AND RECEIVERS

US 380
SEGMENT A

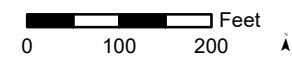
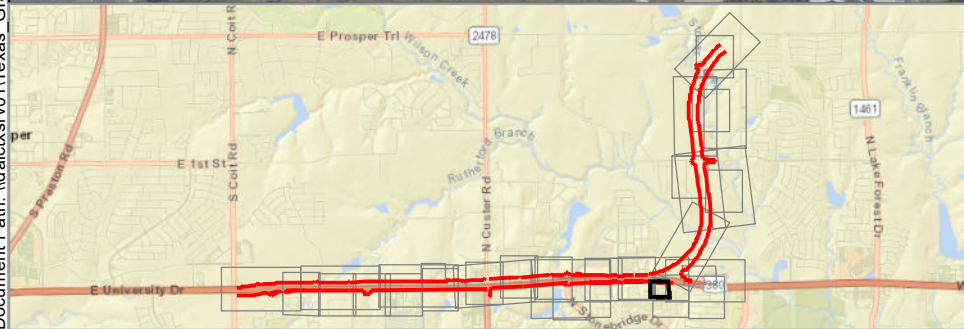
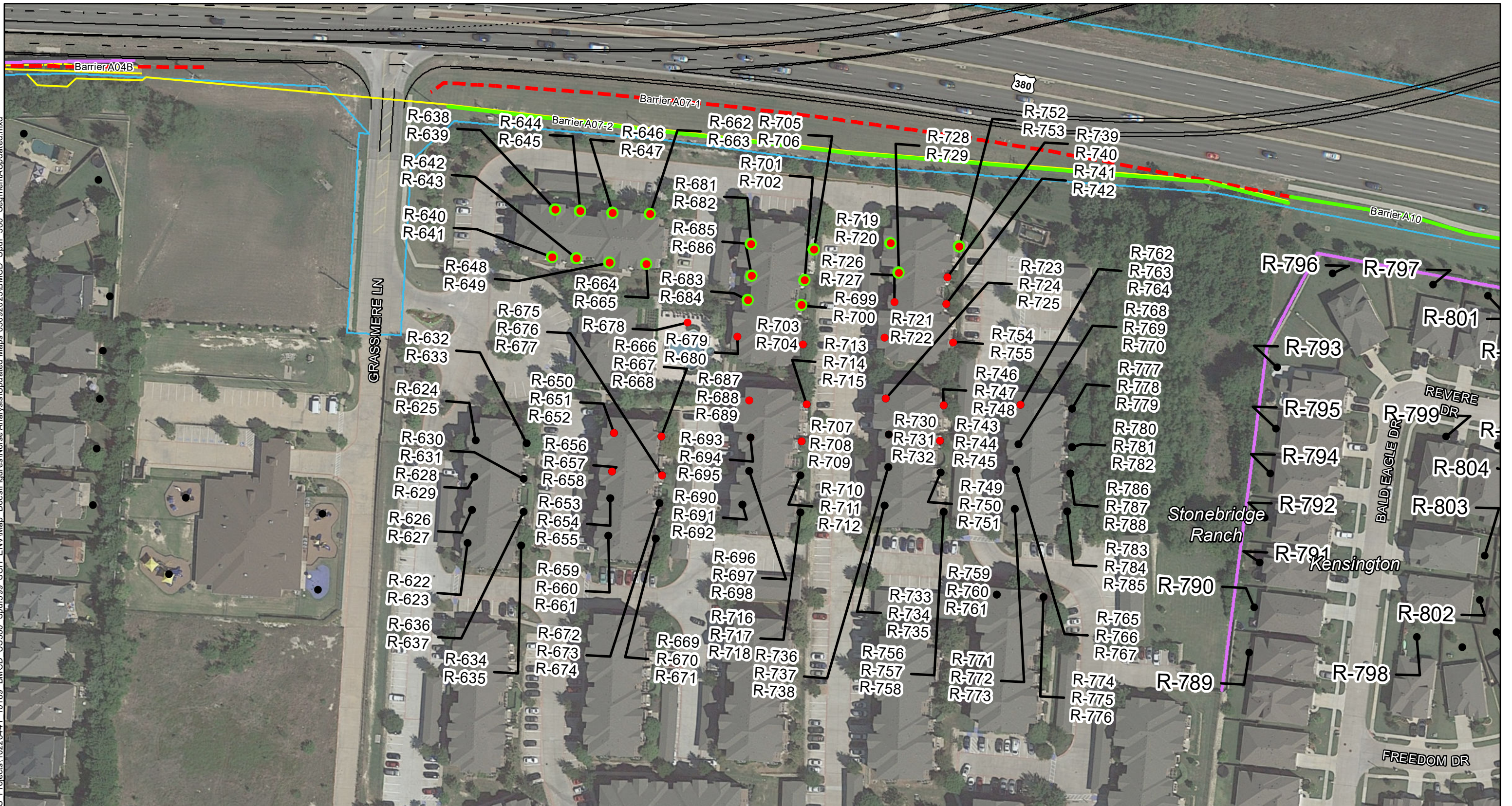


FIGURE A-8
JUNE 2023



Legend

- PROPOSED BARRIER
- - - BARRIER ANALYZED BUT NOT PROPOSED
- IMPACTED RECEIVER
- NON-IMPACTED RECEIVER
- BENEFITED RECEIVER
- RESIDENTIAL DISPLACEMENT
- COMMERCIAL DISPLACEMENT
- EXISTING ROW
- PROPOSED IMPROVEMENTS
- PROPOSED ROW
- EXISTING NEIGHBORHOOD WALLS
- VALIDATION LOCATIONS
- AMBIENT MEASUREMENT SITES

NOISE IMPACTS AND RECEIVERS

US 380
SEGMENT A

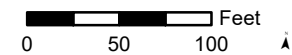
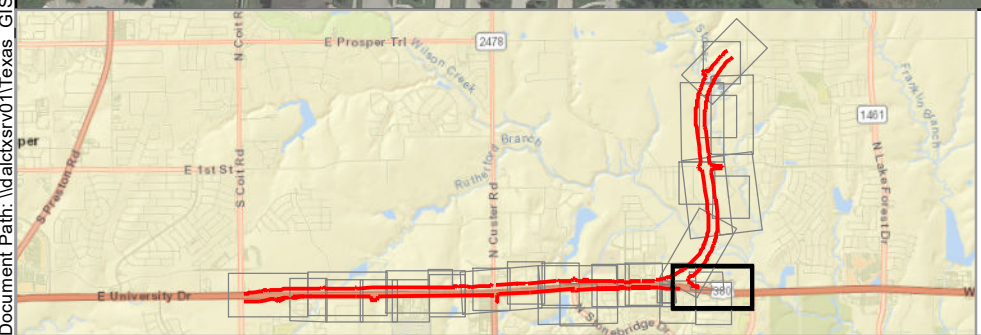
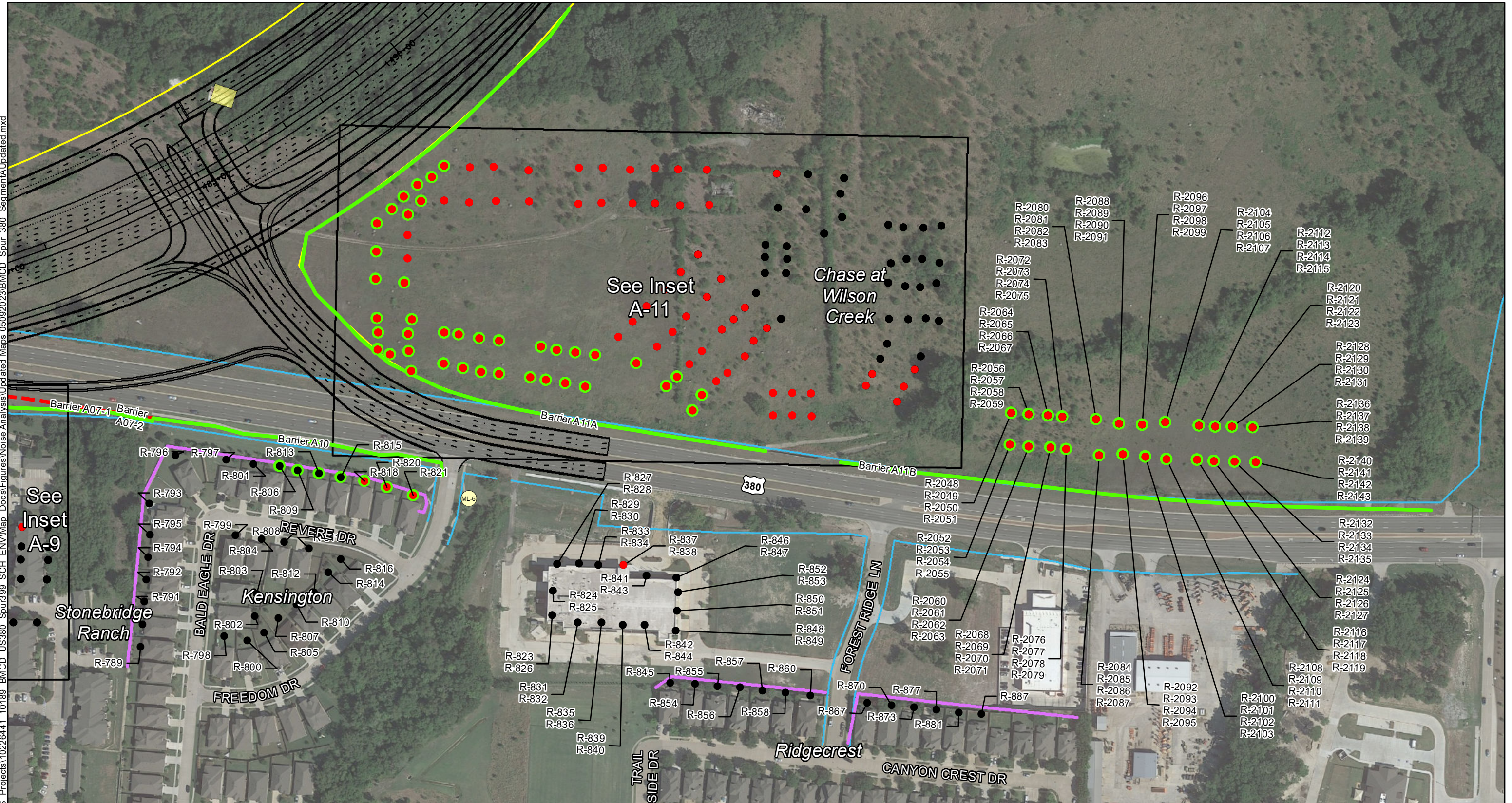


FIGURE A-9
JUNE 2023



Legend

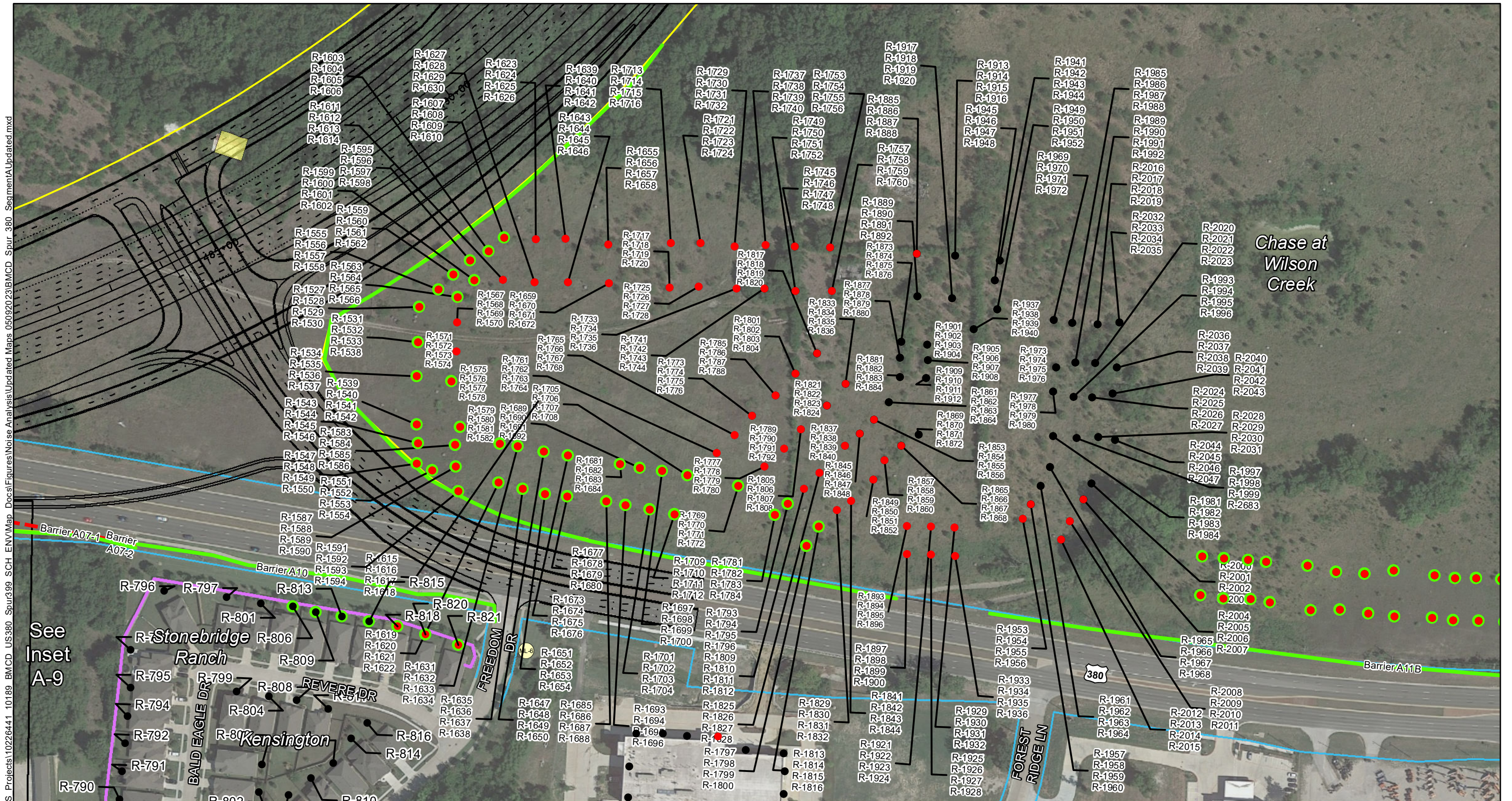
- PROPOSED BARRIER
- - - BARRIER ANALYZED BUT NOT PROPOSED
- IMPACTED RECEIVER
- NON-IMPACTED RECEIVER
- BENEFITED RECEIVER
- RESIDENTIAL DISPLACEMENT
- COMMERCIAL DISPLACEMENT
- EXISTING ROW
- PROPOSED IMPROVEMENTS
- PROPOSED ROW
- EXISTING NEIGHBORHOOD WALLS
- VALIDATION LOCATIONS
- AMBIENT MEASUREMENT SITES

NOISE IMPACTS AND RECEIVERS

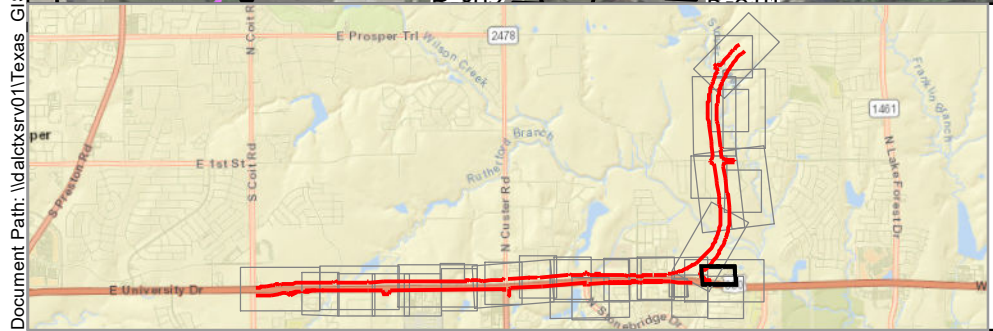
US 380
SEGMENT A

0 100 200 Feet

FIGURE A-10
JUNE 2023



See Inset A-9



Legend

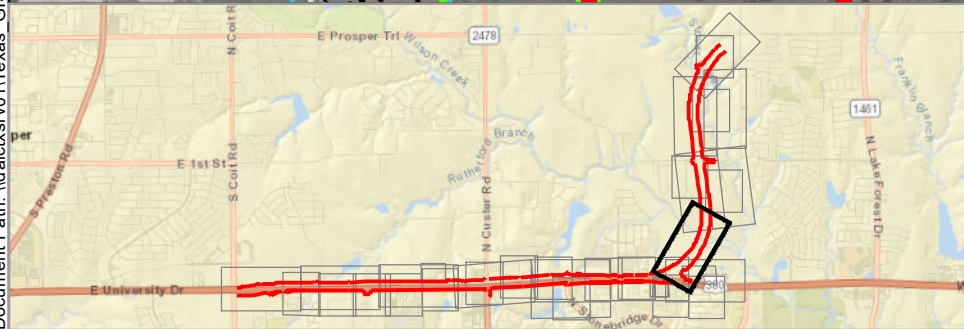
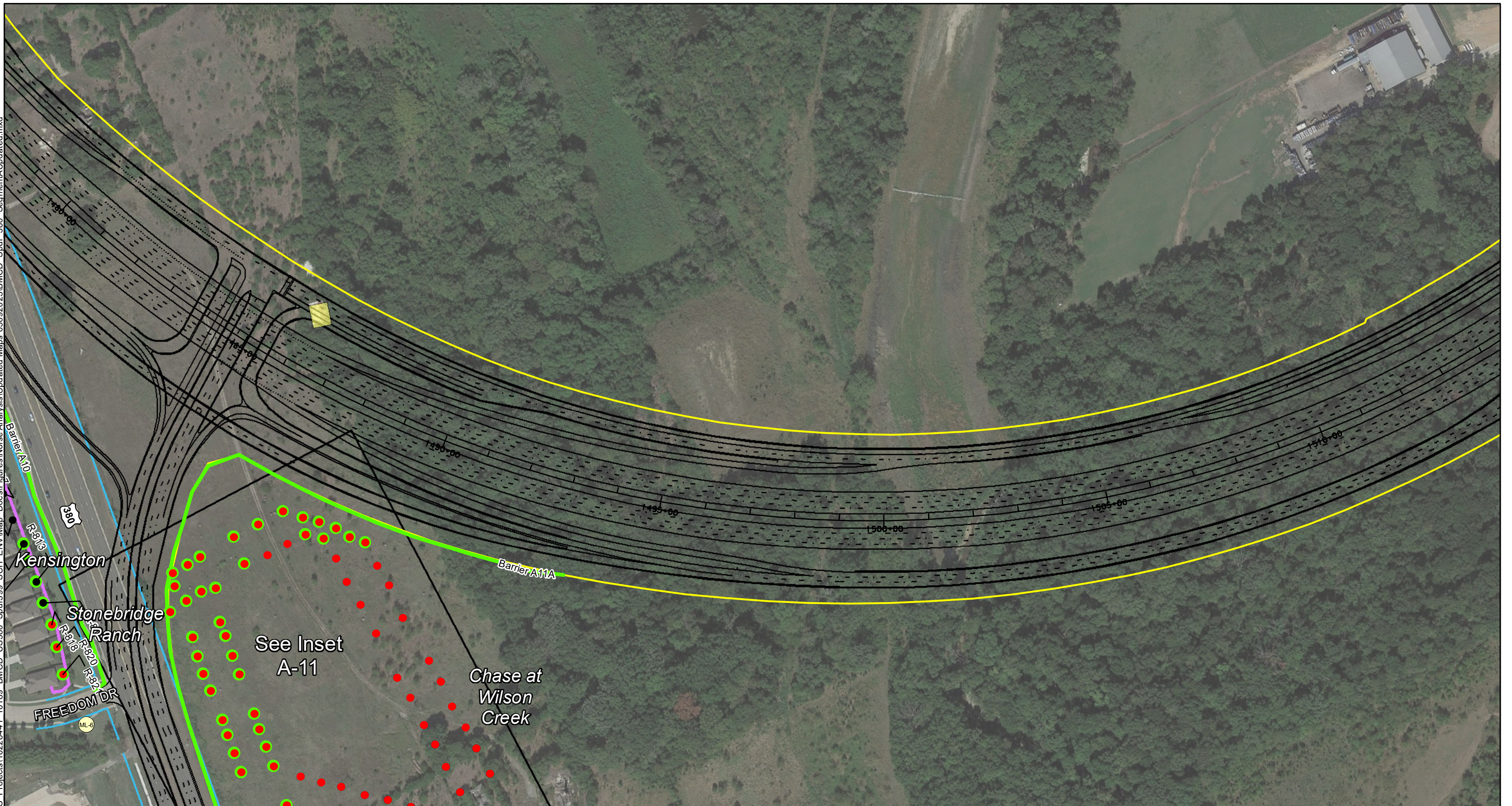
— PROPOSED BARRIER	— EXISTING ROW
- - - BARRIER ANALYZED BUT NOT PROPOSED	— PROPOSED IMPROVEMENTS
● IMPACTED RECEIVER	— PROPOSED ROW
● NON-IMPACTED RECEIVER	— EXISTING NEIGHBORHOOD WALLS
● BENEFITED RECEIVER	● VALIDATION LOCATIONS
 RESIDENTIAL DISPLACEMENT	● AMBIENT MEASUREMENT SITES
 COMMERCIAL DISPLACEMENT	

NOISE IMPACTS AND RECEIVERS

US 380
SEGMENT A

0 80 160 Feet

FIGURE A-11
JUNE 2023



Legend

- PROPOSED BARRIER
- - - BARRIER ANALYZED BUT NOT PROPOSED
- IMPACTED RECEIVER
- NON-IMPACTED RECEIVER
- BENEFITED RECEIVER
- RESIDENTIAL DISPLACEMENT
- COMMERCIAL DISPLACEMENT
- EXISTING ROW
- PROPOSED IMPROVEMENTS
- PROPOSED ROW
- EXISTING NEIGHBORHOOD WALLS
- VALIDATION LOCATIONS
- AMBIENT MEASUREMENT SITES

NOISE IMPACTS AND RECEIVERS

US 380
SEGMENT A

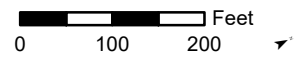
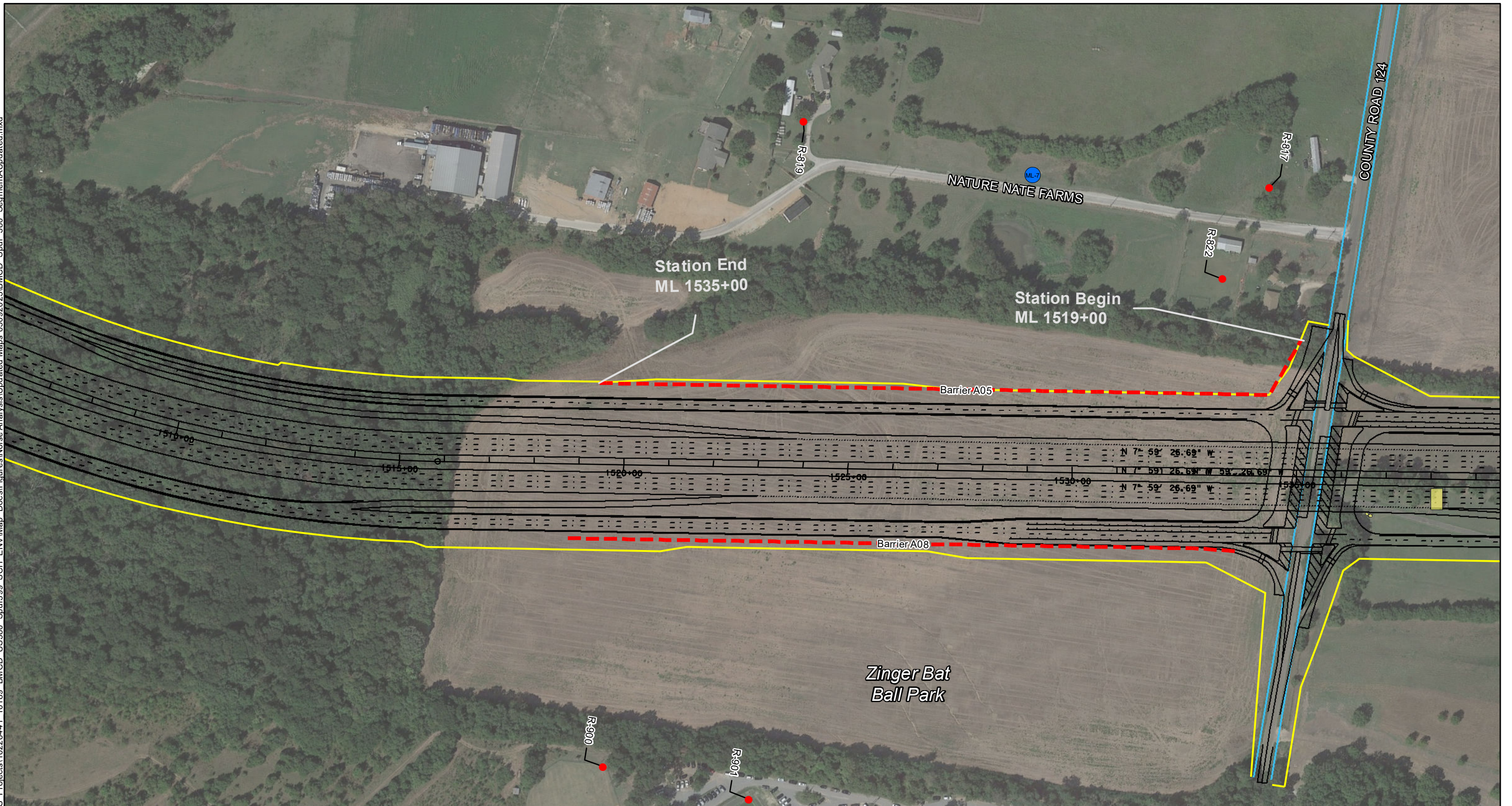


FIGURE A-12
JUNE 2023



Legend

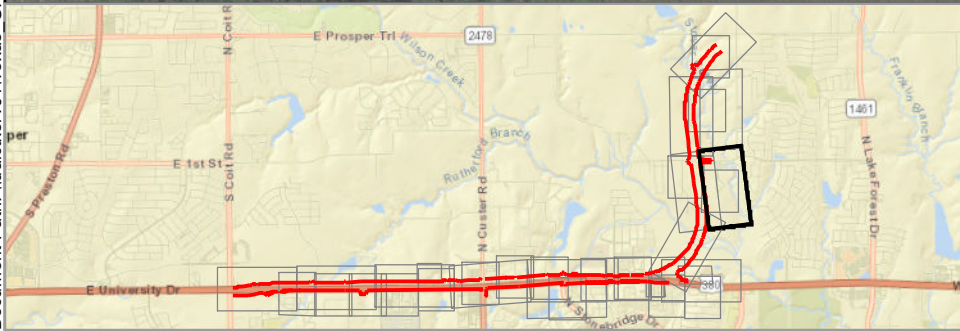
- PROPOSED BARRIER
- - - BARRIER ANALYZED BUT NOT PROPOSED
- IMPACTED RECEIVER
- NON-IMPACTED RECEIVER
- BENEFITED RECEIVER
- RESIDENTIAL DISPLACEMENT
- COMMERCIAL DISPLACEMENT
- EXISTING ROW
- PROPOSED IMPROVEMENTS
- PROPOSED ROW
- EXISTING NEIGHBORHOOD WALLS
- VALIDATION LOCATIONS
- AMBIENT MEASUREMENT SITES

NOISE IMPACTS AND RECEIVERS

US 380
SEGMENT A



FIGURE A-13
JUNE 2023



Legend

- PROPOSED BARRIER
- - - BARRIER ANALYZED BUT NOT PROPOSED
- IMPACTED RECEIVER
- NON-IMPACTED RECEIVER
- BENEFITED RECEIVER
- RESIDENTIAL DISPLACEMENT
- COMMERCIAL DISPLACEMENT
- EXISTING ROW
- PROPOSED IMPROVEMENTS
- PROPOSED ROW
- EXISTING NEIGHBORHOOD WALLS
- VALIDATION LOCATIONS
- AMBIENT MEASUREMENT SITES

NOISE IMPACTS AND RECEIVERS

US 380
SEGMENT A

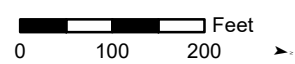
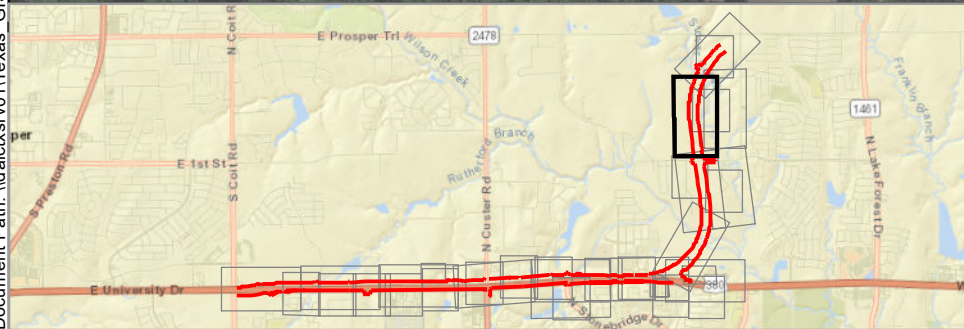
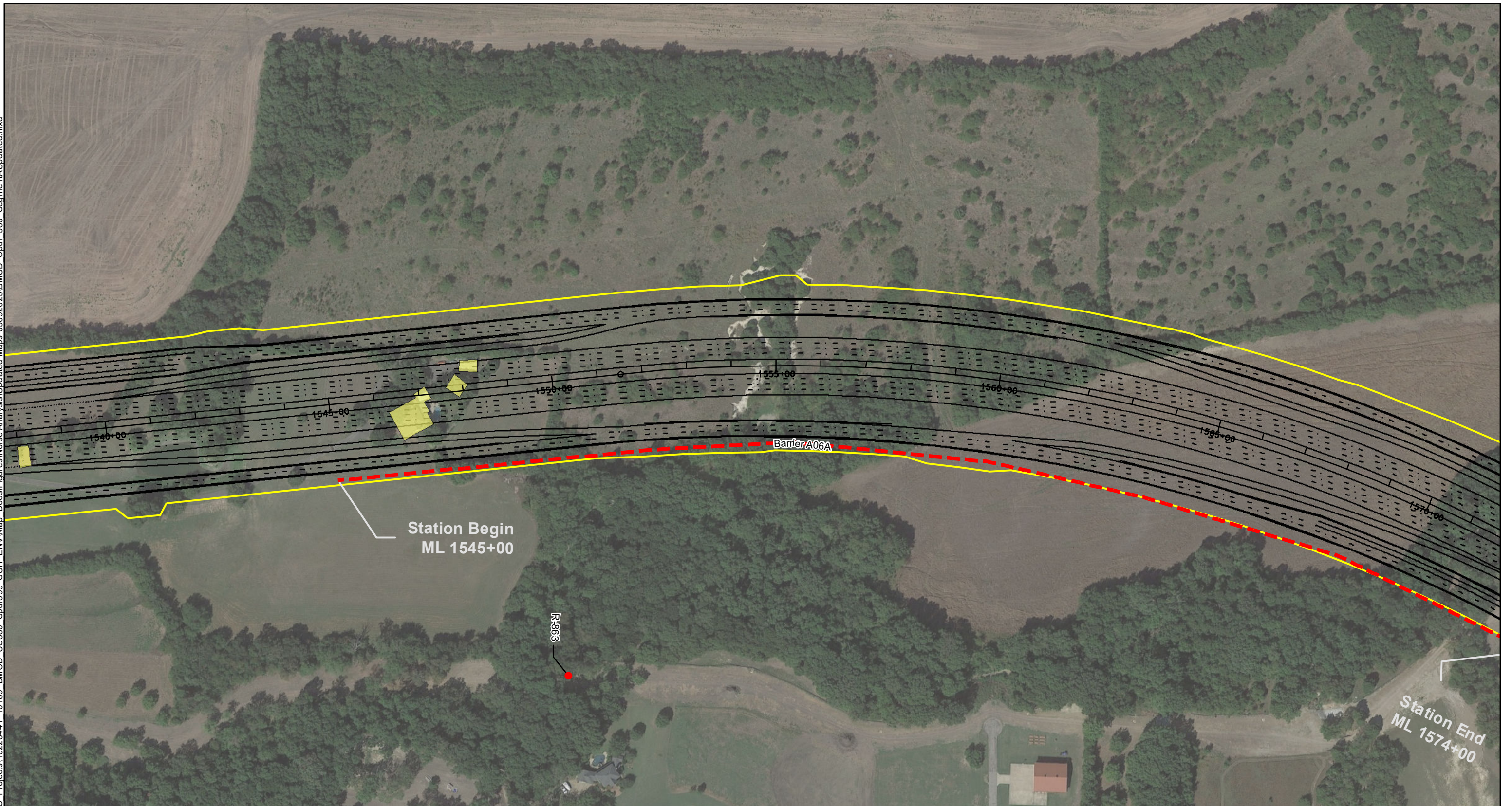


FIGURE A-14
JUNE 2023



Legend

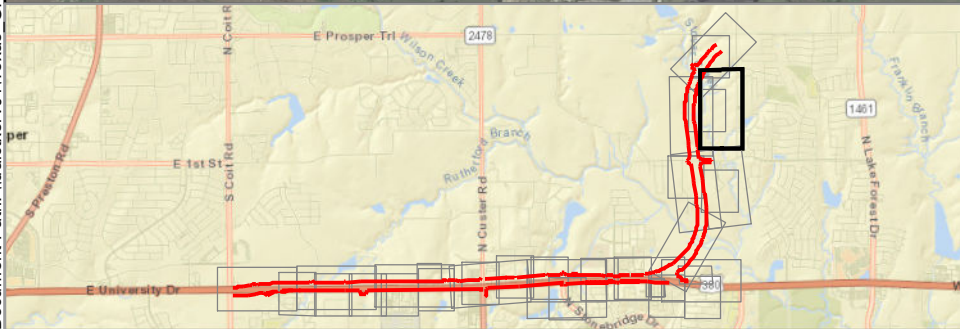
- PROPOSED BARRIER
- - - BARRIER ANALYZED BUT NOT PROPOSED
- IMPACTED RECEIVER
- NON-IMPACTED RECEIVER
- BENEFITED RECEIVER
- RESIDENTIAL DISPLACEMENT
- COMMERCIAL DISPLACEMENT
- EXISTING ROW
- PROPOSED IMPROVEMENTS
- PROPOSED ROW
- EXISTING NEIGHBORHOOD WALLS
- VALIDATION LOCATIONS
- AMBIENT MEASUREMENT SITES

NOISE IMPACTS AND RECEIVERS

US 380
SEGMENT A



FIGURE A-15
JUNE 2023



Legend	
	PROPOSED BARRIER
	BARRIER ANALYZED BUT NOT PROPOSED
	IMPACTED RECEIVER
	NON-IMPACTED RECEIVER
	BENEFITED RECEIVER
	RESIDENTIAL DISPLACEMENT
	COMMERCIAL DISPLACEMENT
	EXISTING ROW
	PROPOSED IMPROVEMENTS
	PROPOSED ROW
	EXISTING NEIGHBORHOOD WALLS
	VALIDATION LOCATIONS
	AMBIENT MEASUREMENT SITES

NOISE IMPACTS AND RECEIVERS

US 380
SEGMENT A

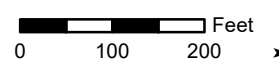
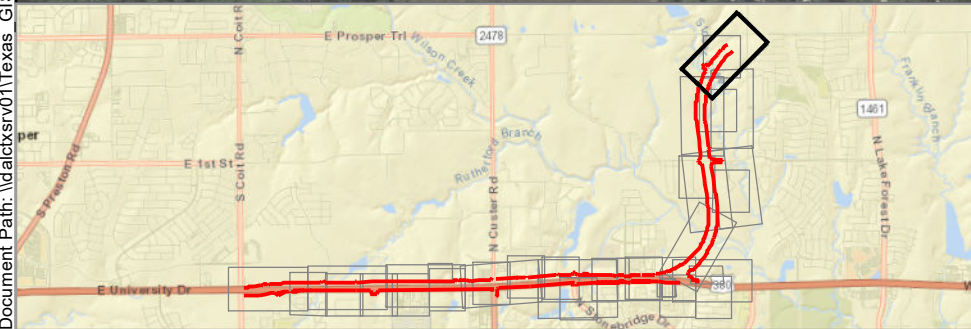
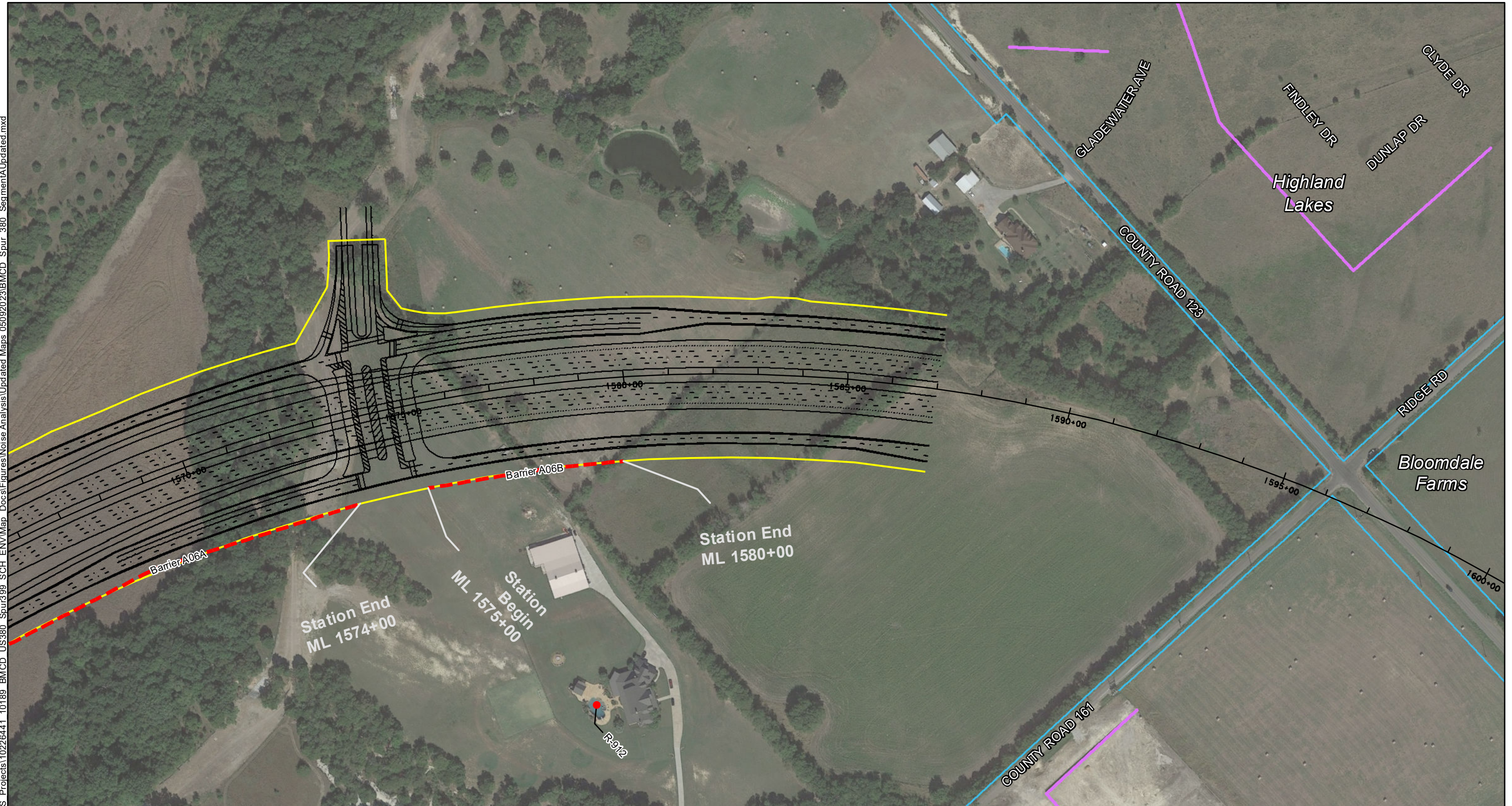


FIGURE A-16
JUNE 2023



Legend

- PROPOSED BARRIER
- BARRIER ANALYZED BUT NOT PROPOSED
- IMPACTED RECEIVER
- NON-IMPACTED RECEIVER
- BENEFITED RECEIVER
- RESIDENTIAL DISPLACEMENT
- COMMERCIAL DISPLACEMENT
- EXISTING ROW
- PROPOSED IMPROVEMENTS
- PROPOSED ROW
- EXISTING NEIGHBORHOOD WALLS
- VALIDATION LOCATIONS
- AMBIENT MEASUREMENT SITES

NOISE IMPACTS AND RECEIVERS

US 380
SEGMENT A

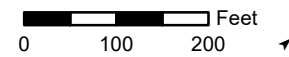
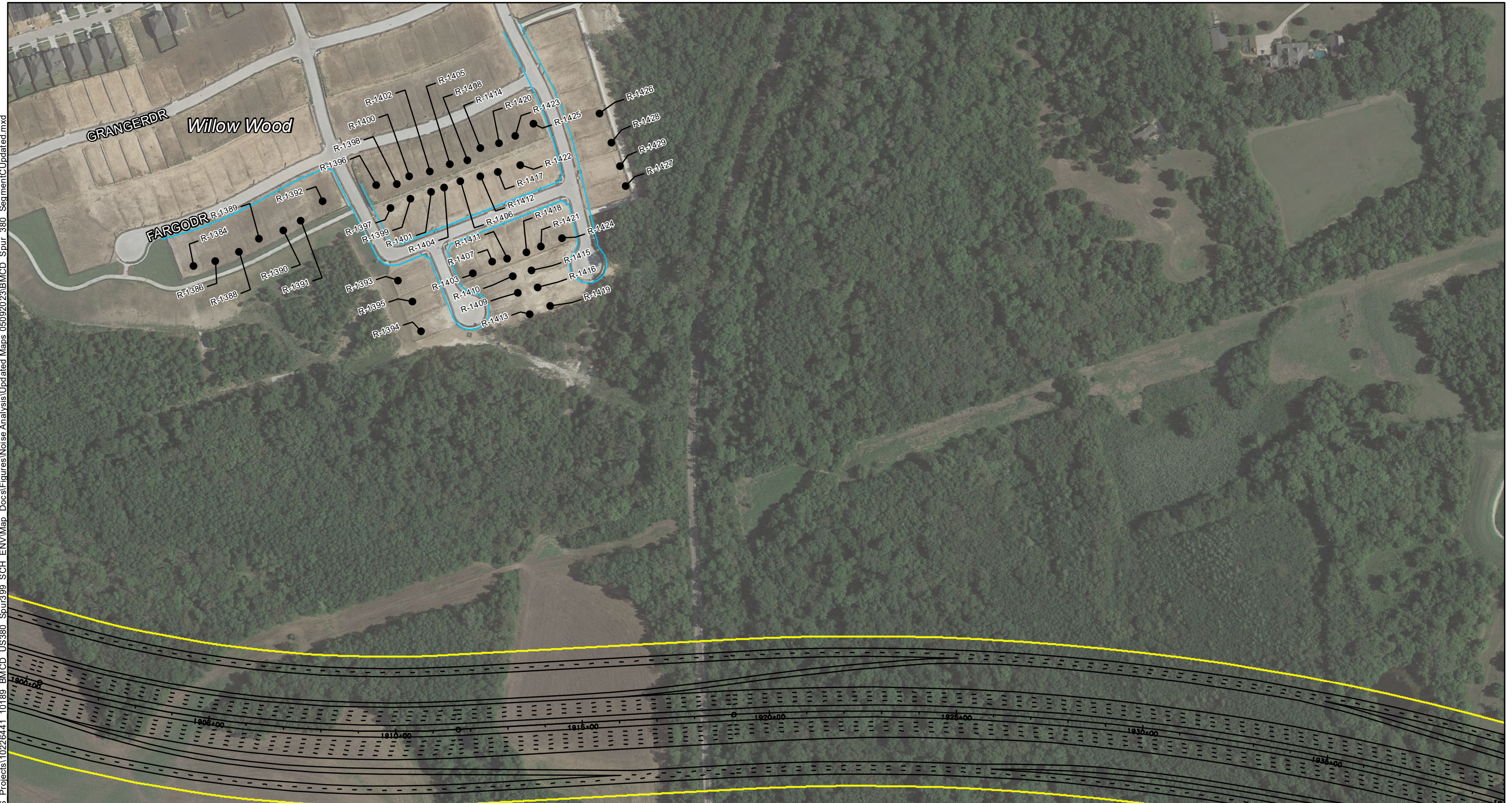


FIGURE A-17
JUNE 2023



Legend

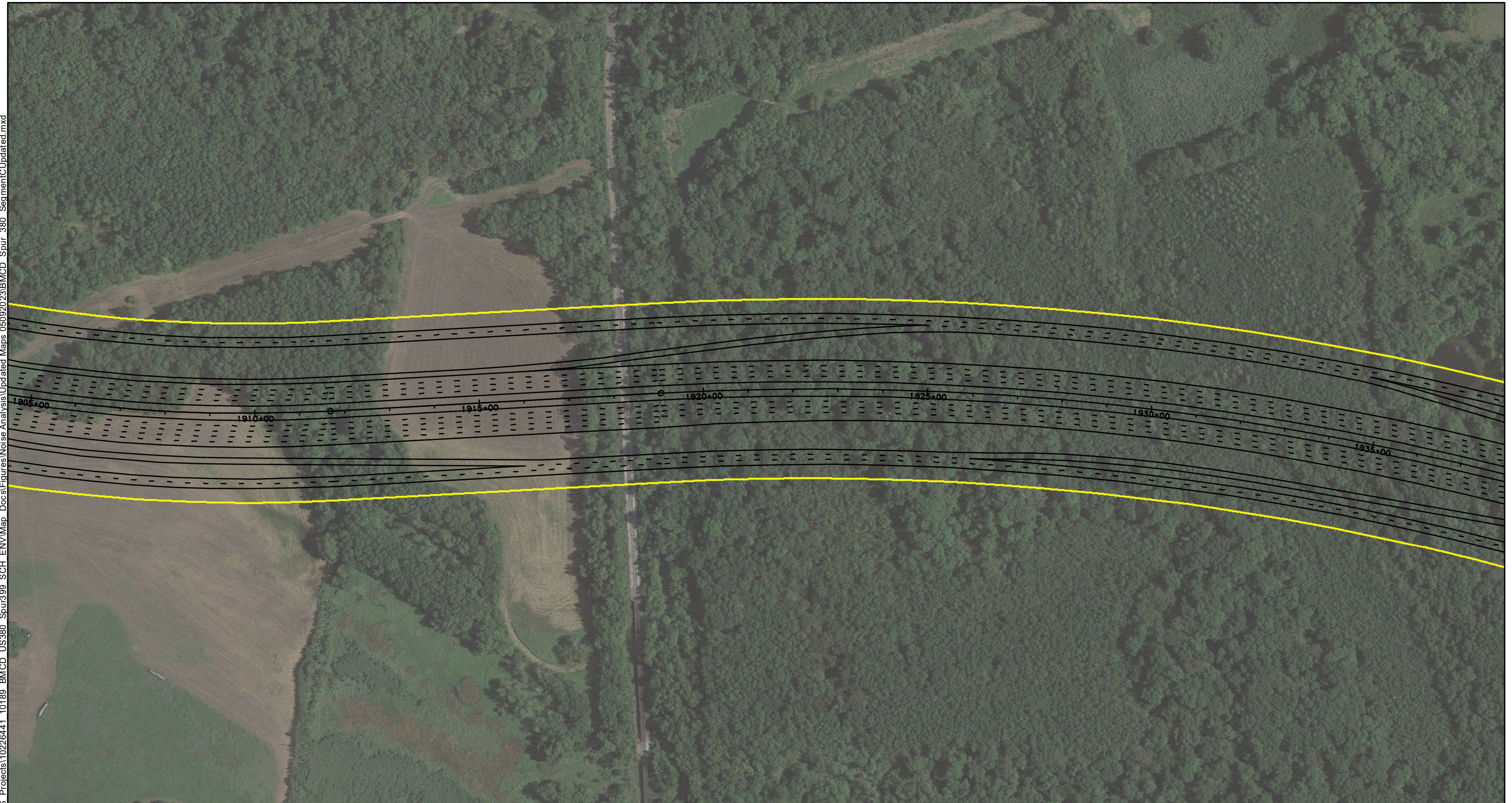
PROPOSED BARRIER	EXISTING ROW
BARRIER ANALYZED BUT NOT PROPOSED	PROPOSED IMPROVEMENTS
IMPACTED RECEIVER	PROPOSED ROW
NON-IMPACTED RECEIVER	EXISTING NEIGHBORHOOD WALLS
BENEFITED RECEIVER	VALIDATION LOCATIONS
RESIDENTIAL DISPLACEMENT	AMBIENT MEASUREMENT SITES
COMMERCIAL DISPLACEMENT	

NOISE IMPACTS AND RECEIVERS

US 380
SEGMENT C

0 120 240 Feet

FIGURE C-1
JUNE 2023



Legend

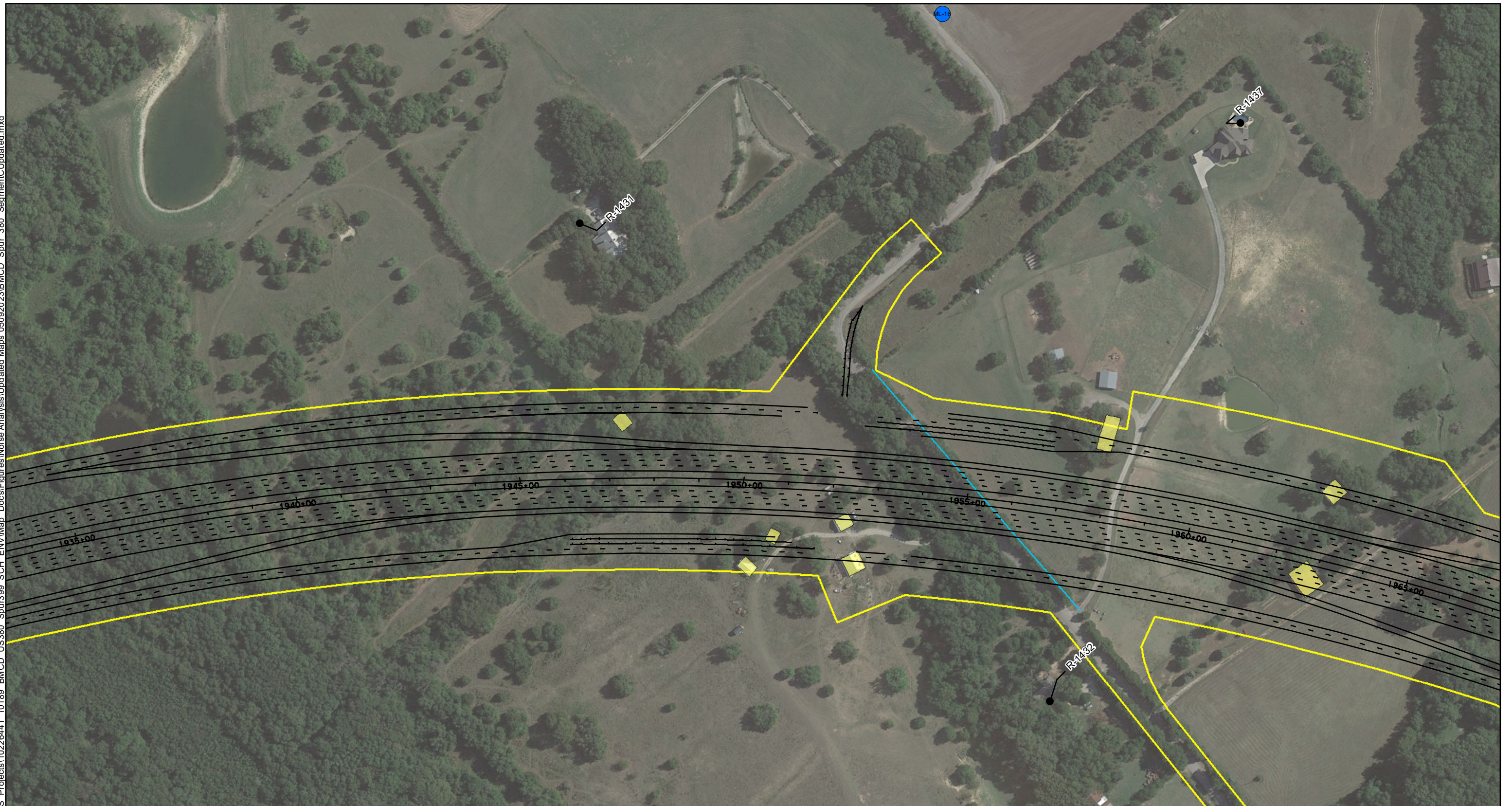
PROPOSED BARRIER	EXISTING ROW
BARRIER ANALYZED BUT NOT PROPOSED	PROPOSED IMPROVEMENTS
IMPACTED RECEIVER	PROPOSED ROW
NON-IMPACTED RECEIVER	EXISTING NEIGHBORHOOD WALLS
BENEFITED RECEIVER	VALIDATION LOCATIONS
RESIDENTIAL DISPLACEMENT	AMBIENT MEASUREMENT SITES
COMMERCIAL DISPLACEMENT	

NOISE IMPACTS AND RECEIVERS

US 380
SEGMENT C

0 100 200 Feet

FIGURE C-2
JUNE 2023



Legend

- PROPOSED BARRIER
- - - BARRIER ANALYZED BUT NOT PROPOSED
- IMPACTED RECEIVER
- NON-IMPACTED RECEIVER
- BENEFITED RECEIVER
- RESIDENTIAL DISPLACEMENT
- COMMERCIAL DISPLACEMENT
- EXISTING ROW
- - - PROPOSED IMPROVEMENTS
- PROPOSED ROW
- EXISTING NEIGHBORHOOD WALLS
- VALIDATION LOCATIONS
- AMBIENT MEASUREMENT SITES

NOISE IMPACTS AND RECEIVERS

US 380
SEGMENT C

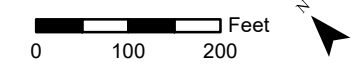


FIGURE C-3
JUNE 2023



Legend

PROPOSED BARRIER	EXISTING ROW
BARRIER ANALYZED BUT NOT PROPOSED	PROPOSED IMPROVEMENTS
IMPACTED RECEIVER	PROPOSED ROW
NON-IMPACTED RECEIVER	EXISTING NEIGHBORHOOD WALLS
BENEFITED RECEIVER	VALIDATION LOCATIONS
RESIDENTIAL DISPLACEMENT	AMBIENT MEASUREMENT SITES
COMMERCIAL DISPLACEMENT	

NOISE IMPACTS AND RECEIVERS

US 380
SEGMENT C

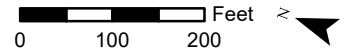


FIGURE C-4
JUNE 2023



Legend

- PROPOSED BARRIER
- BARRIER ANALYZED BUT NOT PROPOSED
- IMPACTED RECEIVER
- NON-IMPACTED RECEIVER
- BENEFITED RECEIVER
- RESIDENTIAL DISPLACEMENT
- COMMERCIAL DISPLACEMENT
- EXISTING ROW
- PROPOSED IMPROVEMENTS
- PROPOSED ROW
- EXISTING NEIGHBORHOOD WALLS
- VALIDATION LOCATIONS
- AMBIENT MEASUREMENT SITES

NOISE IMPACTS AND RECEIVERS

US 380
SEGMENT C

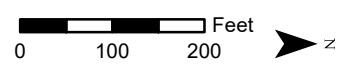
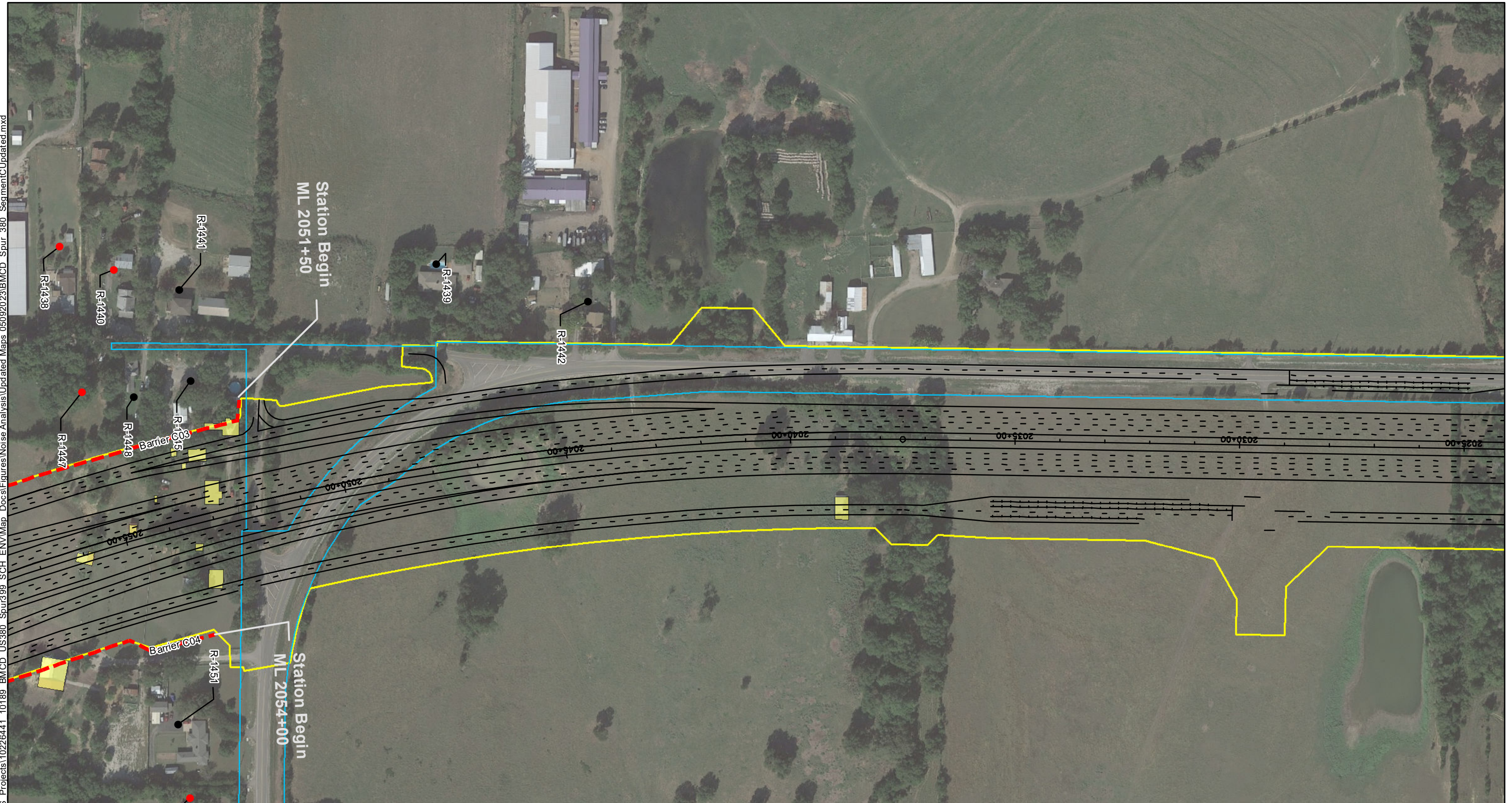


FIGURE C-5
JUNE 2023



Legend	
	PROPOSED BARRIER
	BARRIER ANALYZED BUT NOT PROPOSED
	IMPACTED RECEIVER
	NON-IMPACTED RECEIVER
	BENEFITED RECEIVER
	RESIDENTIAL DISPLACEMENT
	COMMERCIAL DISPLACEMENT
	EXISTING ROW
	PROPOSED IMPROVEMENTS
	PROPOSED ROW
	EXISTING NEIGHBORHOOD WALLS
	VALIDATION LOCATIONS
	AMBIENT MEASUREMENT SITES

NOISE IMPACTS AND RECEIVERS

US 380
SEGMENT C

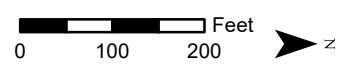
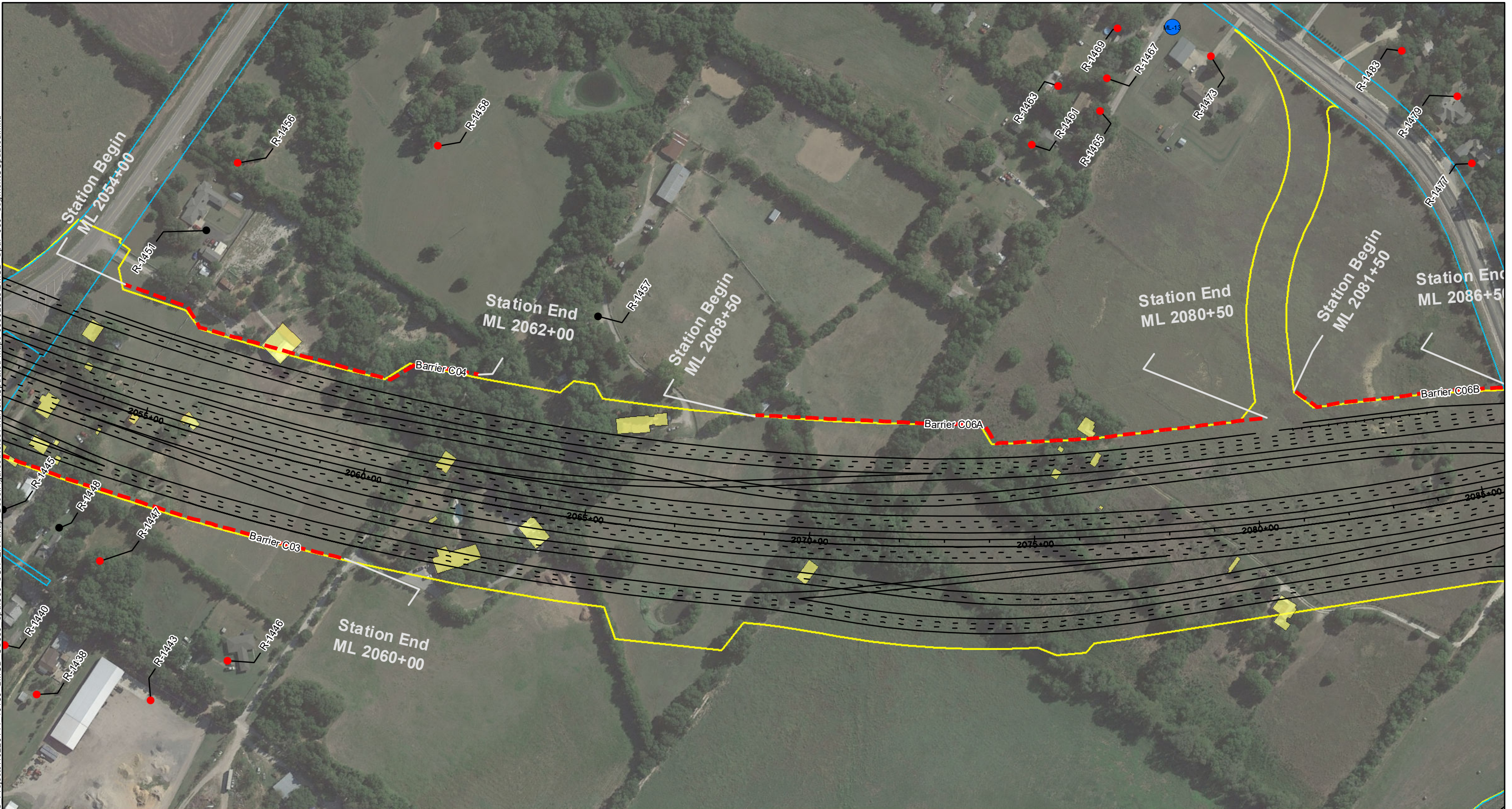


FIGURE C-6
JUNE 2023



Legend

- PROPOSED BARRIER
- - - BARRIER ANALYZED BUT NOT PROPOSED
- IMPACTED RECEIVER
- NON-IMPACTED RECEIVER
- BENEFITED RECEIVER
- RESIDENTIAL DISPLACEMENT
- COMMERCIAL DISPLACEMENT
- EXISTING ROW
- PROPOSED IMPROVEMENTS
- PROPOSED ROW
- EXISTING NEIGHBORHOOD WALLS
- VALIDATION LOCATIONS
- AMBIENT MEASUREMENT SITES

NOISE IMPACTS AND RECEIVERS

US 380
SEGMENT C

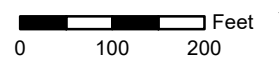


FIGURE C-7
JUNE 2023



Legend

- PROPOSED BARRIER
- - - BARRIER ANALYZED BUT NOT PROPOSED
- IMPACTED RECEIVER
- NON-IMPACTED RECEIVER
- BENEFITED RECEIVER
- RESIDENTIAL DISPLACEMENT
- COMMERCIAL DISPLACEMENT
- EXISTING ROW
- PROPOSED IMPROVEMENTS
- PROPOSED ROW
- EXISTING NEIGHBORHOOD WALLS
- VALIDATION LOCATIONS
- AMBIENT MEASUREMENT SITES

NOISE IMPACTS AND RECEIVERS

US 380
SEGMENT C

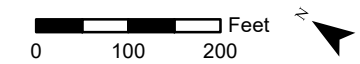


FIGURE C-8
JUNE 2023



Legend

- PROPOSED BARRIER
- BARRIER ANALYZED BUT NOT PROPOSED
- IMPACTED RECEIVER
- NON-IMPACTED RECEIVER
- BENEFITED RECEIVER
- RESIDENTIAL DISPLACEMENT
- COMMERCIAL DISPLACEMENT
- EXISTING ROW
- PROPOSED IMPROVEMENTS
- PROPOSED ROW
- EXISTING NEIGHBORHOOD WALLS
- VALIDATION LOCATIONS
- AMBIENT MEASUREMENT SITES

NOISE IMPACTS AND RECEIVERS

US 380
SEGMENT C

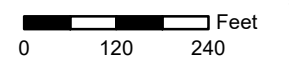
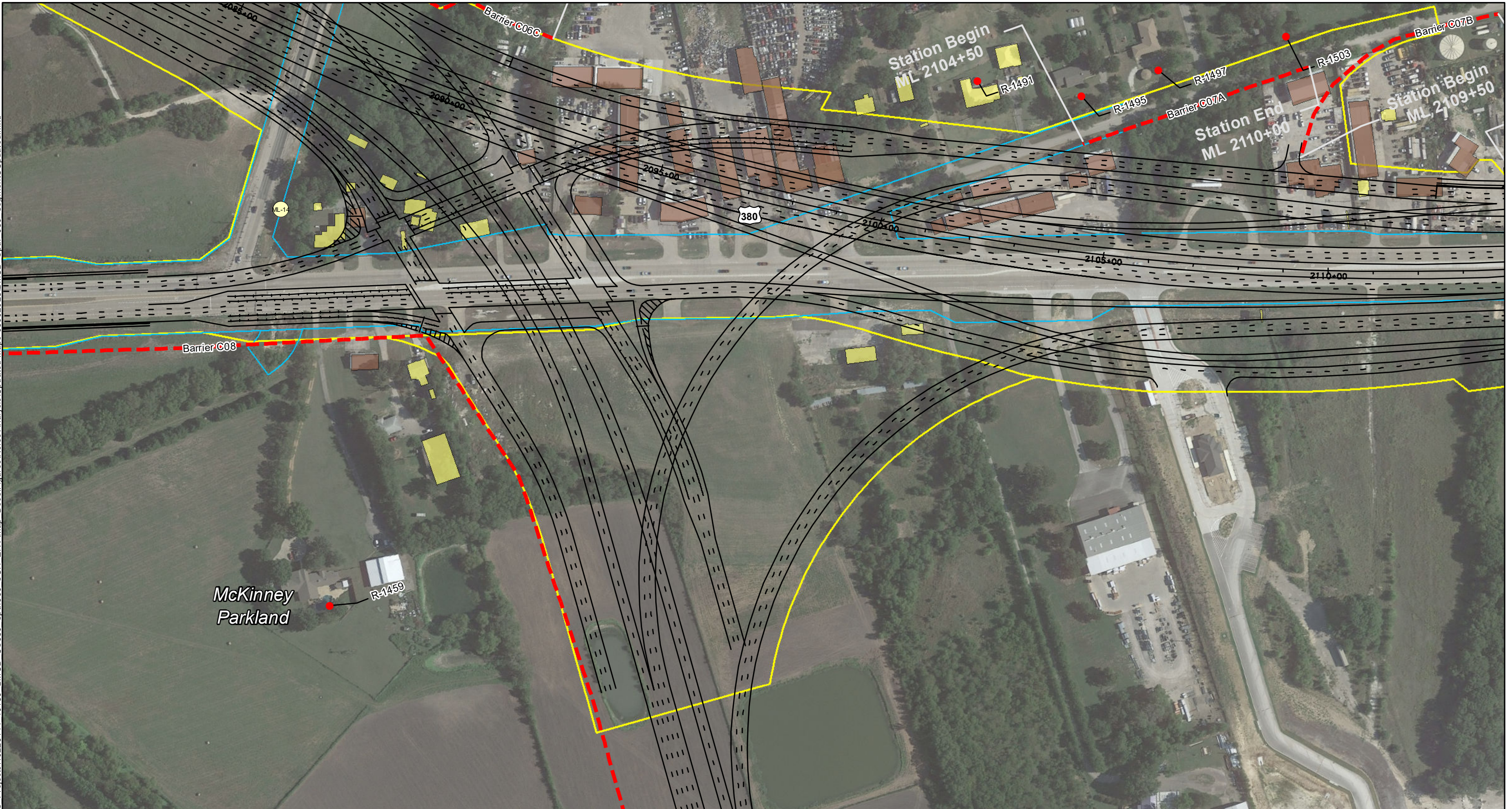


FIGURE C-9
JUNE 2023



Legend

- PROPOSED BARRIER
- - - BARRIER ANALYZED BUT NOT PROPOSED
- IMPACTED RECEIVER
- NON-IMPACTED RECEIVER
- BENEFITED RECEIVER
- RESIDENTIAL DISPLACEMENT
- COMMERCIAL DISPLACEMENT
- EXISTING ROW
- PROPOSED IMPROVEMENTS
- PROPOSED ROW
- EXISTING NEIGHBORHOOD WALLS
- VALIDATION LOCATIONS
- AMBIENT MEASUREMENT SITES

NOISE IMPACTS AND RECEIVERS

US 380
SEGMENT C

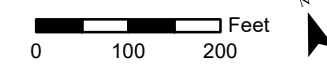


FIGURE C-10
JUNE 2023

Document Path: \\dalctskv01\Texas_GIS_Projects\10226441_10189_BMCD_US380_Spur399_SCH_ENV\Map_Docs\Figures\Noise Analysis\Updated Maps_06092023\BMCD_Spur_380_SegmentC_Updated.mxd



Legend

- PROPOSED BARRIER
- - - BARRIER ANALYZED BUT NOT PROPOSED
- IMPACTED RECEIVER
- NON-IMPACTED RECEIVER
- BENEFITED RECEIVER
- RESIDENTIAL DISPLACEMENT
- COMMERCIAL DISPLACEMENT
- EXISTING ROW
- PROPOSED IMPROVEMENTS
- PROPOSED ROW
- EXISTING NEIGHBORHOOD WALLS
- VALIDATION LOCATIONS
- AMBIENT MEASUREMENT SITES

NOISE IMPACTS AND RECEIVERS

US 380
SEGMENT C

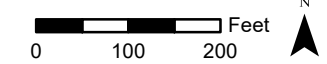
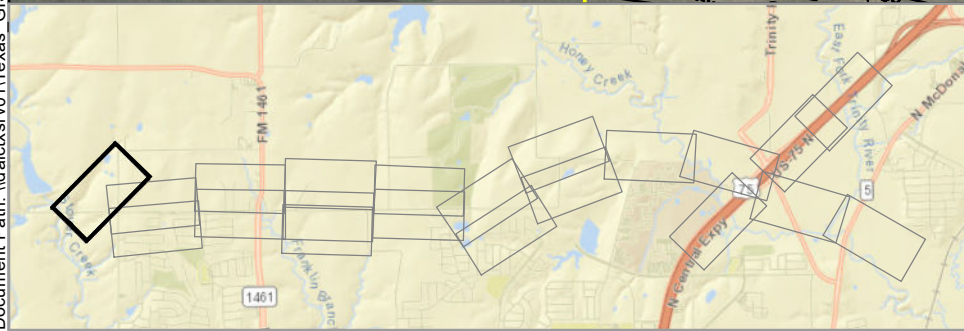


FIGURE C-11
JUNE 2023



Legend

- PROPOSED BARRIER
- - - BARRIER ANALYZED BUT NOT PROPOSED
- IMPACTED RECEIVER
- NON-IMPACTED RECEIVER
- BENEFITED RECEIVER
- RESIDENTIAL DISPLACEMENT
- COMMERCIAL DISPLACEMENT
- EXISTING ROW
- PROPOSED IMPROVEMENTS
- PROPOSED ROW
- EXISTING NEIGHBORHOOD WALLS
- VALIDATION LOCATIONS
- AMBIENT MEASUREMENT SITES

NOISE IMPACTS AND RECEIVERS

US 380
SEGMENT E

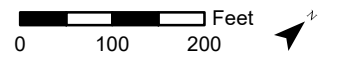
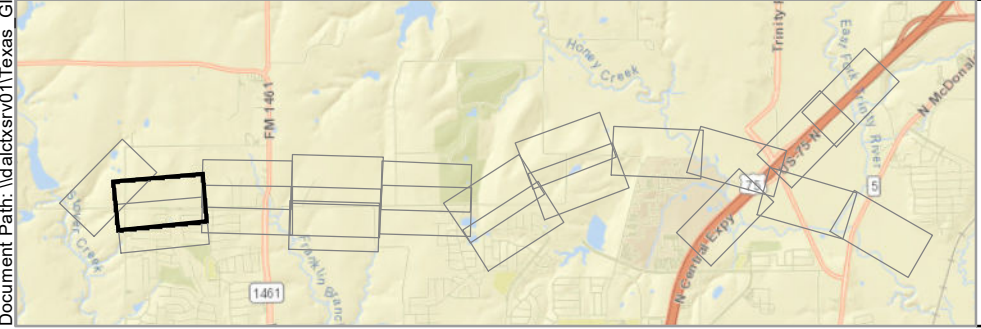
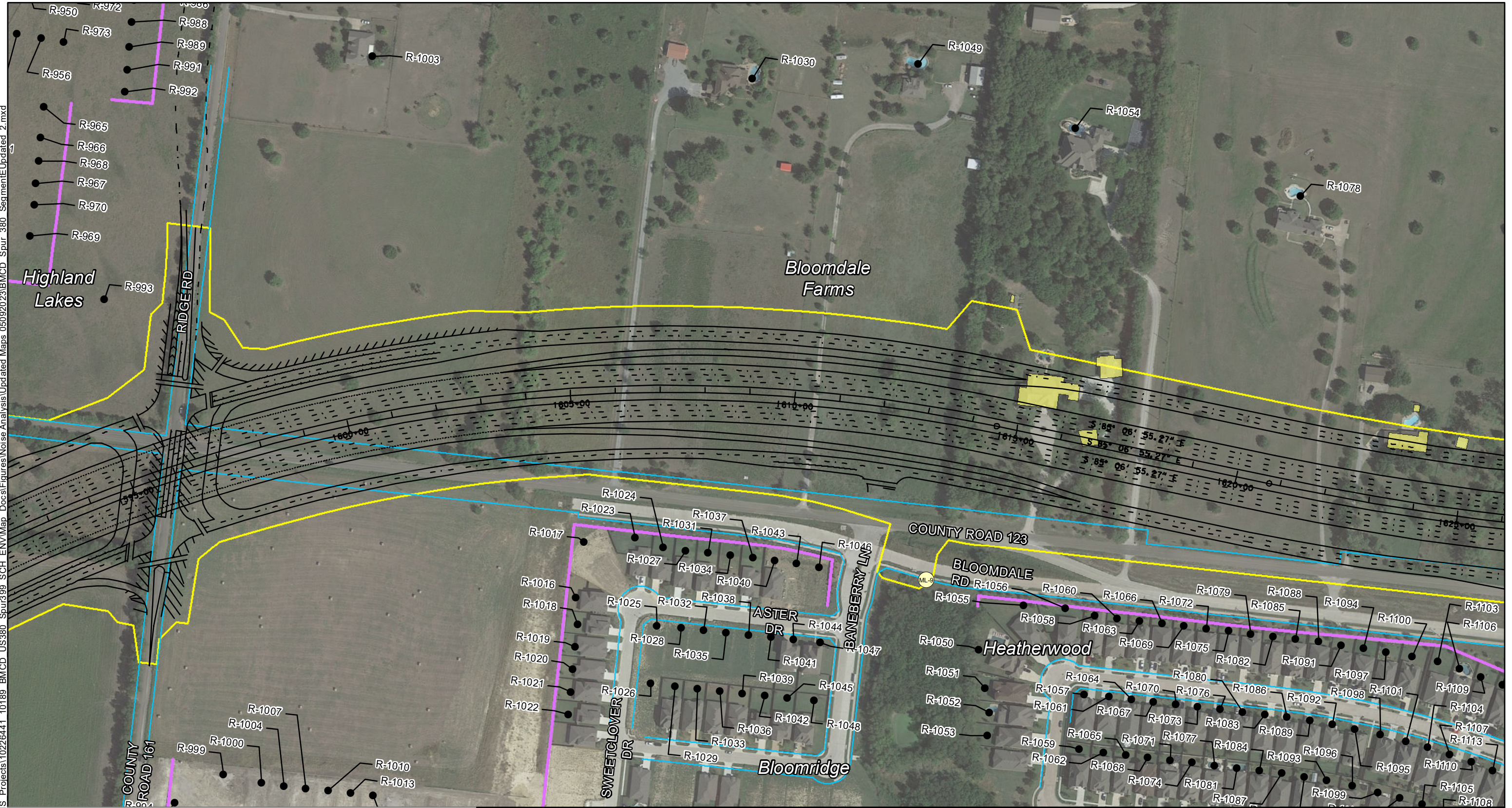


FIGURE E-1
JUNE 2023

Document Path: \\dalctsr\01\Texas GIS Projects\10226441_10189_BMCD_US380_Spur399_SCH_ENV\Map_Docs\Figures\Noise Analysis\Updated Maps_06092023\BMCD_Spur_380_SegmentEUpdated_2.mxd



Legend

- PROPOSED BARRIER
- BARRIER ANALYZED BUT NOT PROPOSED
- IMPACTED RECEIVER
- NON-IMPACTED RECEIVER
- BENEFITED RECEIVER
- RESIDENTIAL DISPLACEMENT
- COMMERCIAL DISPLACEMENT
- EXISTING ROW
- PROPOSED IMPROVEMENTS
- PROPOSED ROW
- EXISTING NEIGHBORHOOD WALLS
- VALIDATION LOCATIONS
- AMBIENT MEASUREMENT SITES

NOISE IMPACTS AND RECEIVERS

US 380
SEGMENT E

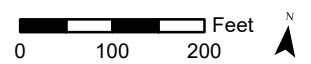
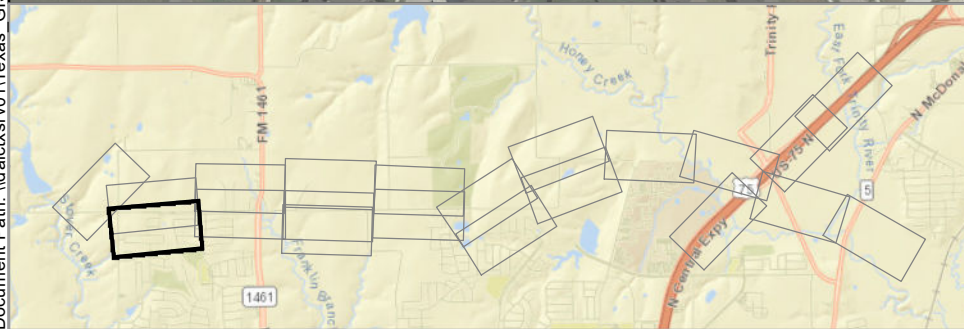


FIGURE E-2
JUNE 2023



Legend

- PROPOSED BARRIER
- BARRIER ANALYZED BUT NOT PROPOSED
- IMPACTED RECEIVER
- NON-IMPACTED RECEIVER
- BENEFITED RECEIVER
- RESIDENTIAL DISPLACEMENT
- COMMERCIAL DISPLACEMENT
- EXISTING ROW
- PROPOSED IMPROVEMENTS
- PROPOSED ROW
- EXISTING NEIGHBORHOOD WALLS
- VALIDATION LOCATIONS
- AMBIENT MEASUREMENT SITES

NOISE IMPACTS AND RECEIVERS

US 380
SEGMENT E

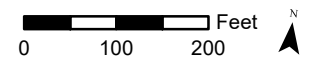
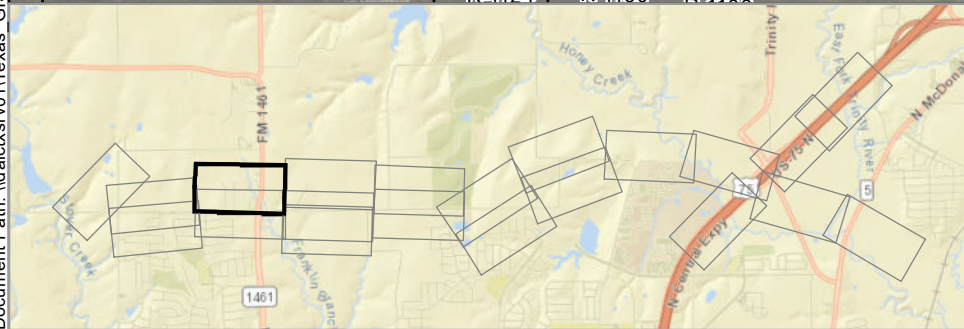
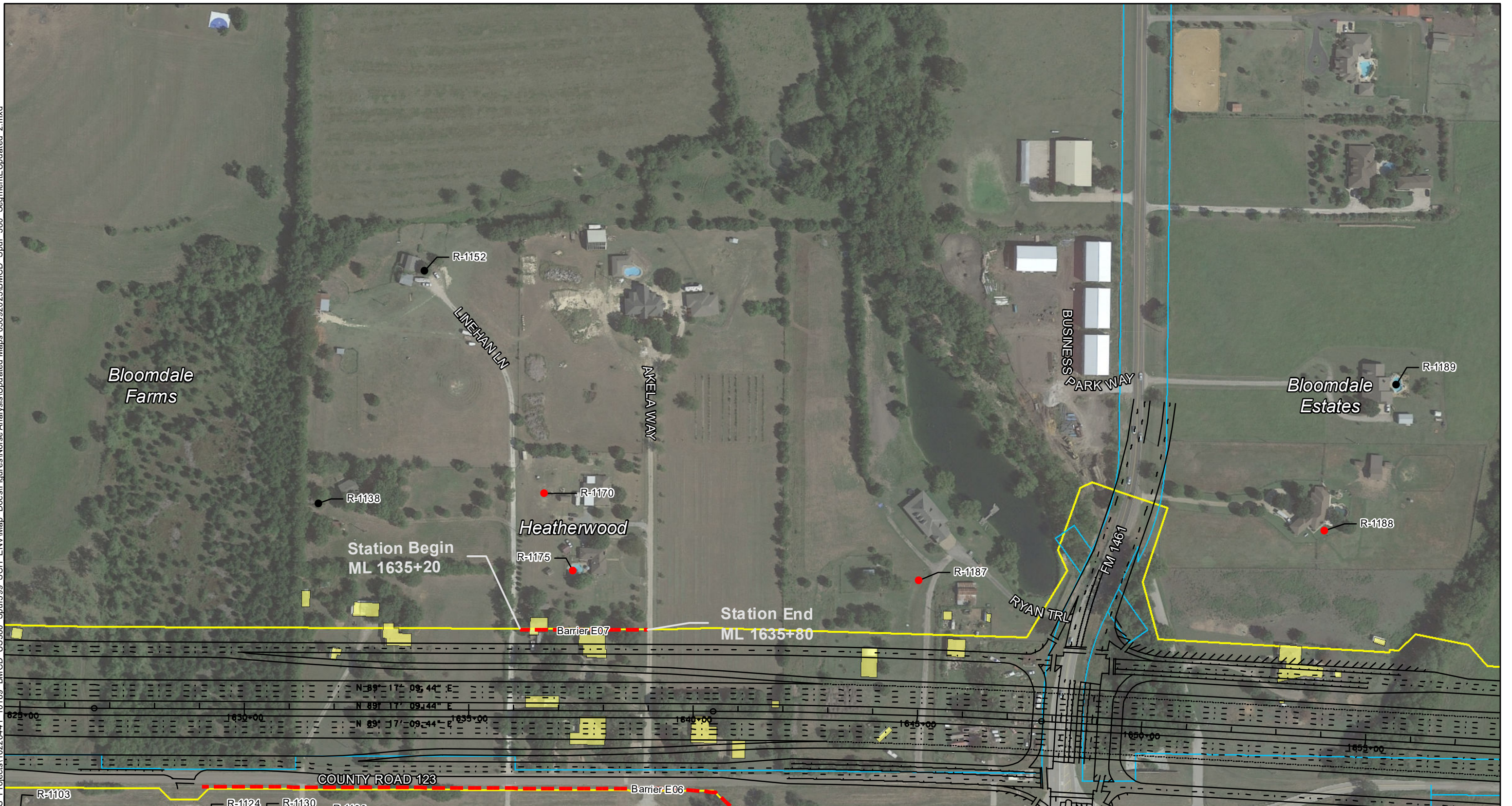


FIGURE E-3
JUNE 2023



Legend

- PROPOSED BARRIER
- - - BARRIER ANALYZED BUT NOT PROPOSED
- IMPACTED RECEIVER
- NON-IMPACTED RECEIVER
- BENEFITED RECEIVER
- RESIDENTIAL DISPLACEMENT
- COMMERCIAL DISPLACEMENT
- EXISTING ROW
- PROPOSED IMPROVEMENTS
- PROPOSED ROW
- EXISTING NEIGHBORHOOD WALLS
- VALIDATION LOCATIONS
- AMBIENT MEASUREMENT SITES

NOISE IMPACTS AND RECEIVERS

US 380
SEGMENT E

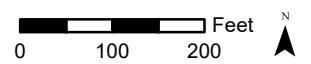
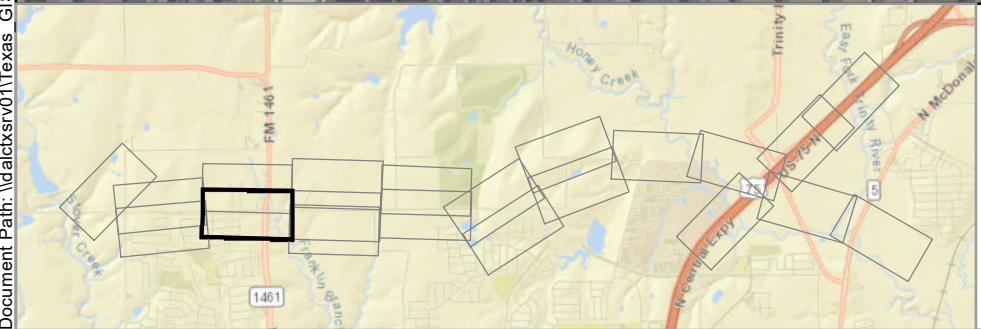
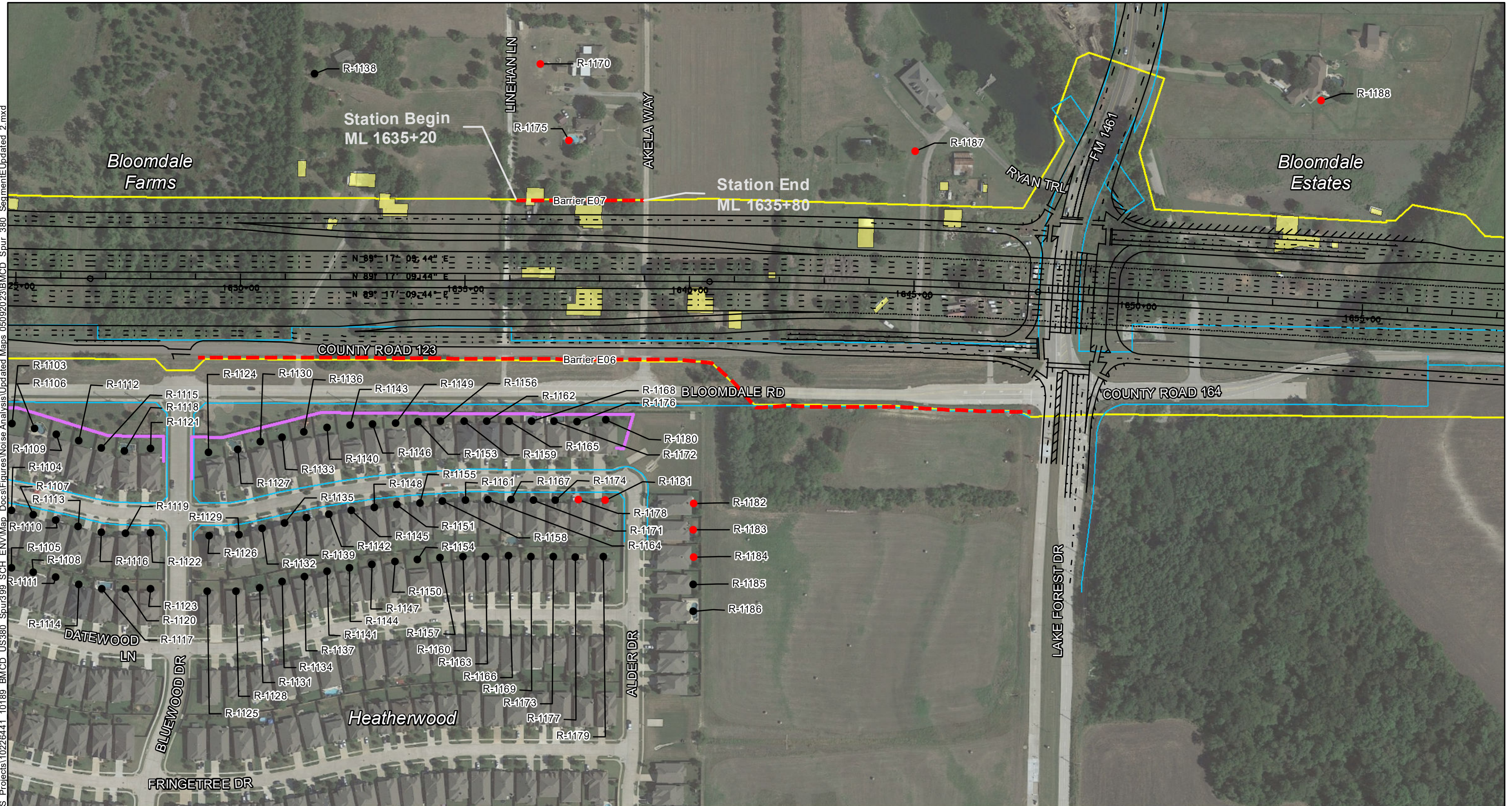


FIGURE E-4
JUNE 2023



Legend

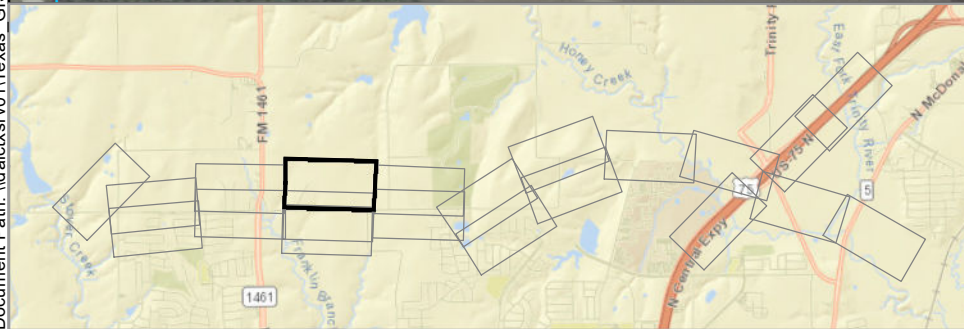
- PROPOSED BARRIER
- - - BARRIER ANALYZED BUT NOT PROPOSED
- IMPACTED RECEIVER
- NON-IMPACTED RECEIVER
- BENEFITED RECEIVER
- RESIDENTIAL DISPLACEMENT
- COMMERCIAL DISPLACEMENT
- EXISTING ROW
- PROPOSED IMPROVEMENTS
- PROPOSED ROW
- EXISTING NEIGHBORHOOD WALLS
- VALIDATION LOCATIONS
- AMBIENT MEASUREMENT SITES

NOISE IMPACTS AND RECEIVERS

US 380
SEGMENT E



FIGURE E-5
JUNE 2023



Legend

- PROPOSED BARRIER
- - - BARRIER ANALYZED BUT NOT PROPOSED
- IMPACTED RECEIVER
- NON-IMPACTED RECEIVER
- BENEFITED RECEIVER
- RESIDENTIAL DISPLACEMENT
- COMMERCIAL DISPLACEMENT
- EXISTING ROW
- PROPOSED IMPROVEMENTS
- PROPOSED ROW
- EXISTING NEIGHBORHOOD WALLS
- VALIDATION LOCATIONS
- AMBIENT MEASUREMENT SITES

NOISE IMPACTS AND RECEIVERS

US 380
SEGMENT E

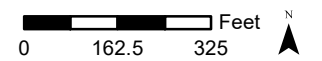
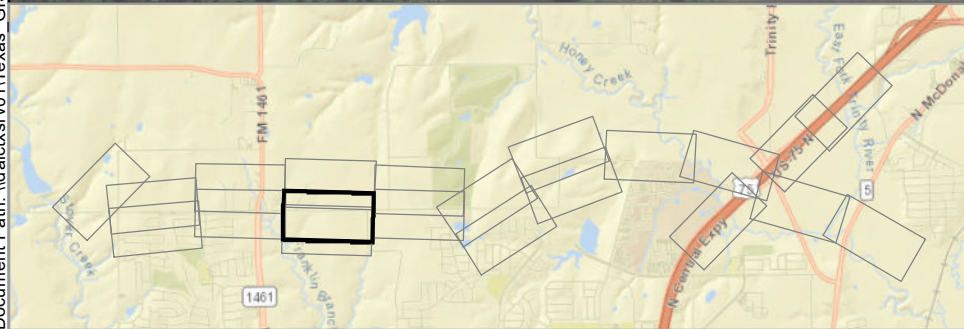


FIGURE E-6
JUNE 2023



Legend

- PROPOSED BARRIER
- - - BARRIER ANALYZED BUT NOT PROPOSED
- IMPACTED RECEIVER
- NON-IMPACTED RECEIVER
- BENEFITED RECEIVER
- RESIDENTIAL DISPLACEMENT
- COMMERCIAL DISPLACEMENT
- EXISTING ROW
- PROPOSED IMPROVEMENTS
- PROPOSED ROW
- EXISTING NEIGHBORHOOD WALLS
- VALIDATION LOCATIONS
- AMBIENT MEASUREMENT SITES

NOISE IMPACTS AND RECEIVERS

US 380
SEGMENT E

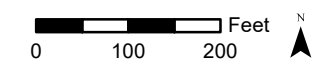
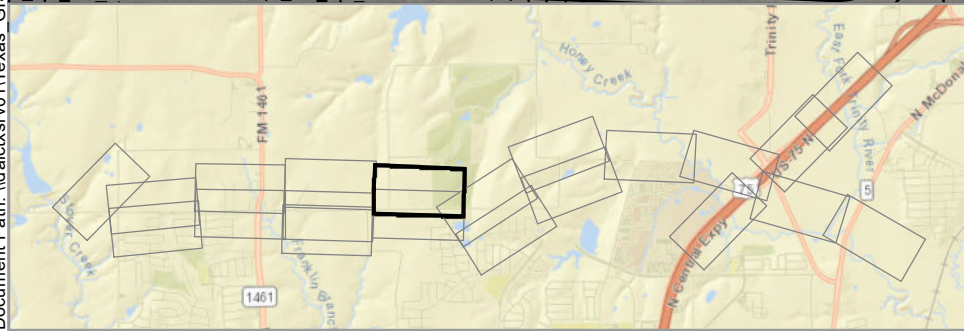


FIGURE E-7
JUNE 2023



Legend

- PROPOSED BARRIER
- - - BARRIER ANALYZED BUT NOT PROPOSED
- IMPACTED RECEIVER
- NON-IMPACTED RECEIVER
- BENEFITED RECEIVER
- RESIDENTIAL DISPLACEMENT
- COMMERCIAL DISPLACEMENT
- EXISTING ROW
- PROPOSED IMPROVEMENTS
- PROPOSED ROW
- EXISTING NEIGHBORHOOD WALLS
- VALIDATION LOCATIONS
- AMBIENT MEASUREMENT SITES

NOISE IMPACTS AND RECEIVERS

US 380
SEGMENT E

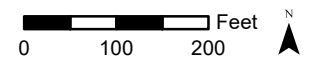
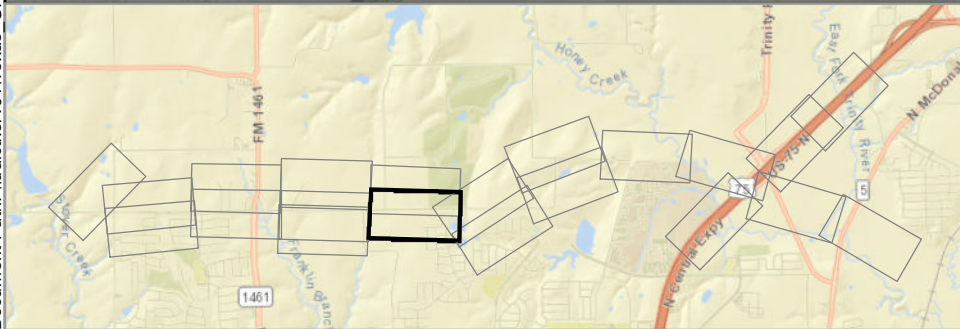
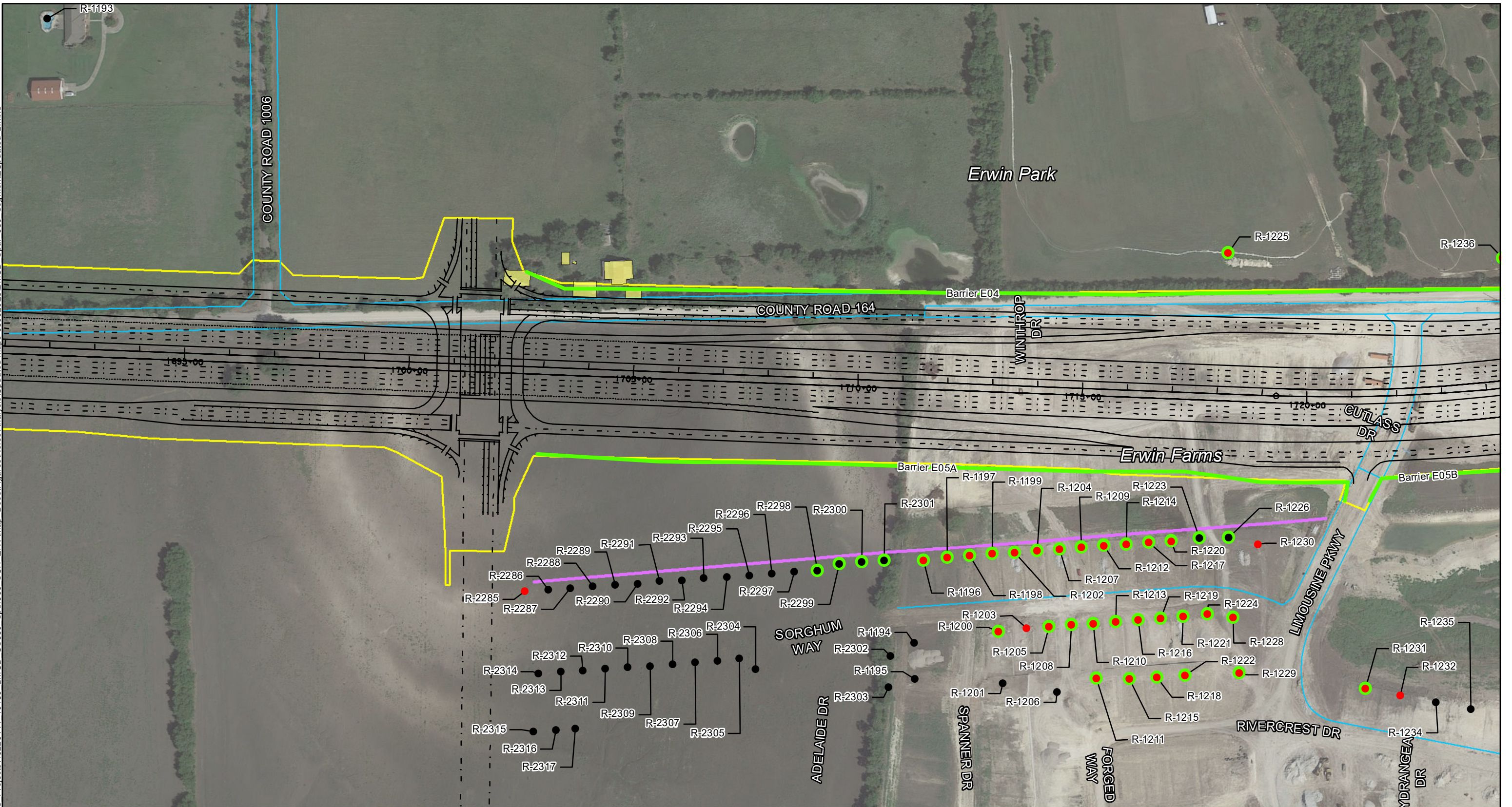


FIGURE E-8
JUNE 2023



Legend

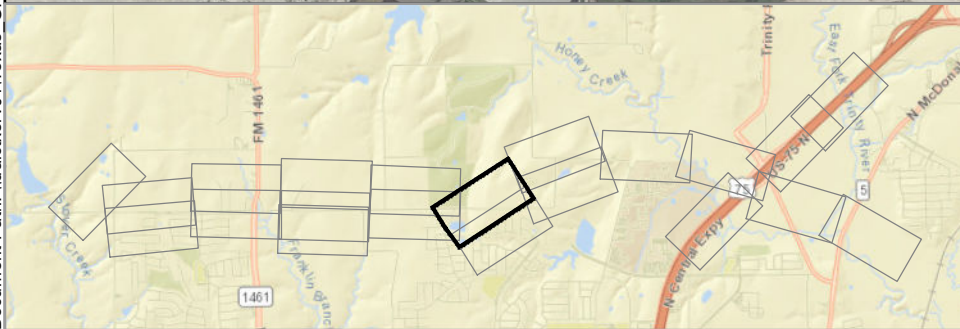
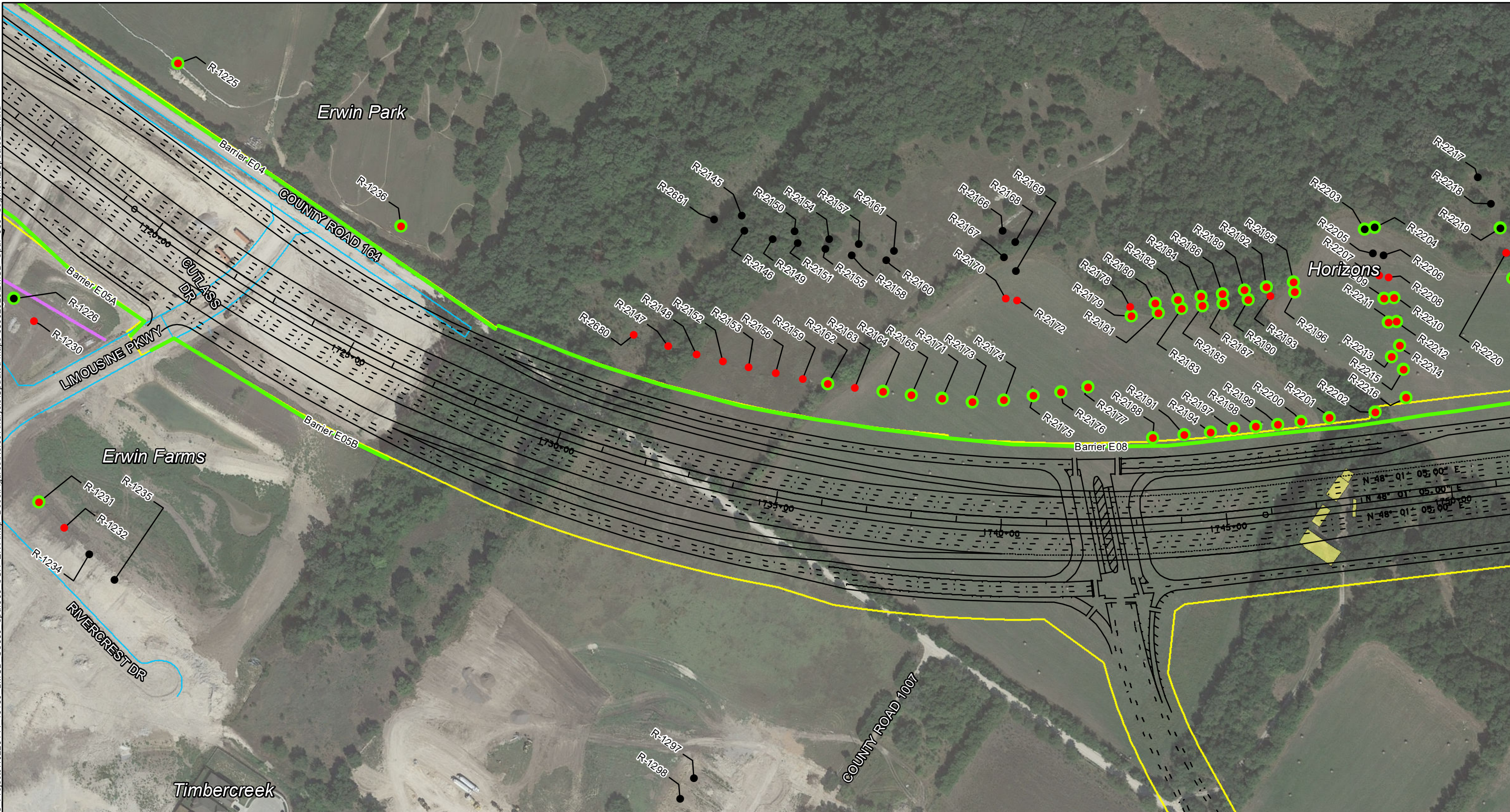
- PROPOSED BARRIER
- BARRIER ANALYZED BUT NOT PROPOSED
- IMPACTED RECEIVER
- NON-IMPACTED RECEIVER
- BENEFITED RECEIVER
- RESIDENTIAL DISPLACEMENT
- COMMERCIAL DISPLACEMENT
- EXISTING ROW
- PROPOSED IMPROVEMENTS
- PROPOSED ROW
- EXISTING NEIGHBORHOOD WALLS
- VALIDATION LOCATIONS
- AMBIENT MEASUREMENT SITES

NOISE IMPACTS AND RECEIVERS

US 380
SEGMENT E



FIGURE E-9
JUNE 2023



Legend

- PROPOSED BARRIER
- BARRIER ANALYZED BUT NOT PROPOSED
- IMPACTED RECEIVER
- NON-IMPACTED RECEIVER
- BENEFITED RECEIVER
- RESIDENTIAL DISPLACEMENT
- COMMERCIAL DISPLACEMENT
- EXISTING ROW
- PROPOSED IMPROVEMENTS
- PROPOSED ROW
- EXISTING NEIGHBORHOOD WALLS
- VALIDATION LOCATIONS
- AMBIENT MEASUREMENT SITES

NOISE IMPACTS AND RECEIVERS

US 380
SEGMENT E

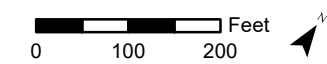
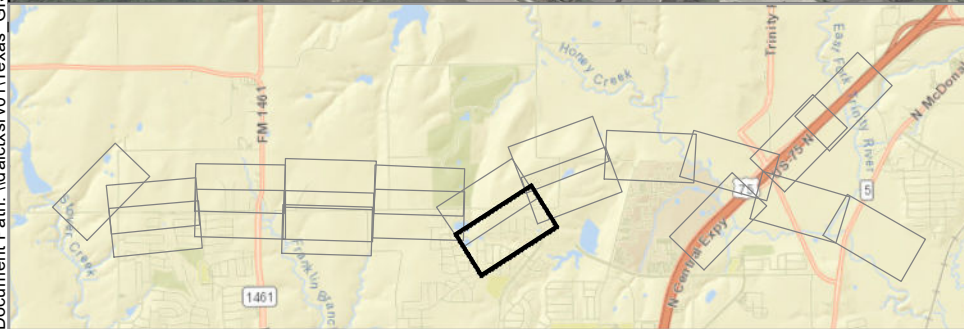
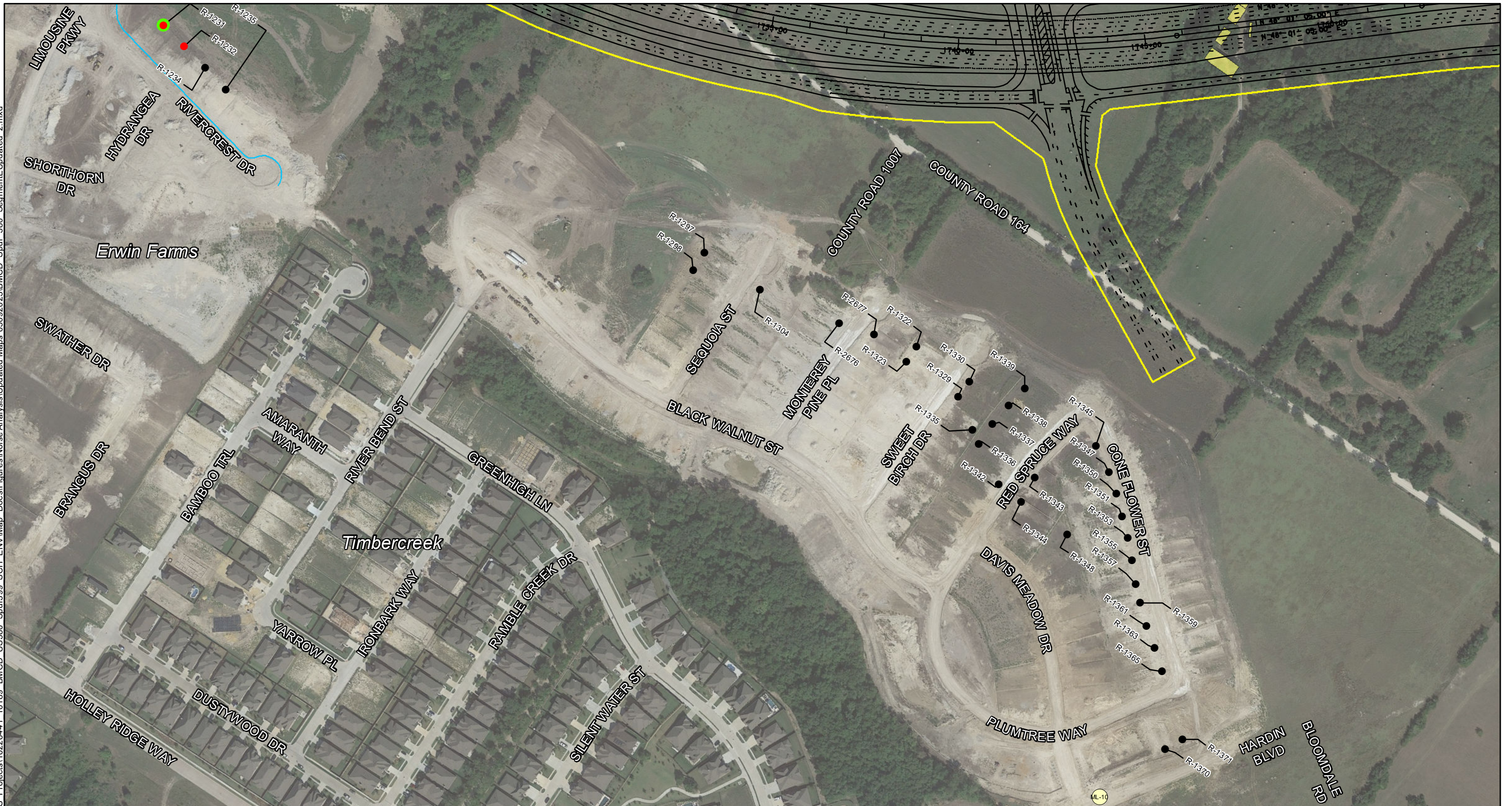


FIGURE E-10
JUNE 2023



Legend

- PROPOSED BARRIER
- BARRIER ANALYZED BUT NOT PROPOSED
- IMPACTED RECEIVER
- NON-IMPACTED RECEIVER
- BENEFITED RECEIVER
- RESIDENTIAL DISPLACEMENT
- COMMERCIAL DISPLACEMENT
- EXISTING ROW
- PROPOSED IMPROVEMENTS
- PROPOSED ROW
- EXISTING NEIGHBORHOOD WALLS
- VALIDATION LOCATIONS
- AMBIENT MEASUREMENT SITES

NOISE IMPACTS AND RECEIVERS

US 380
SEGMENT E

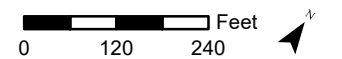
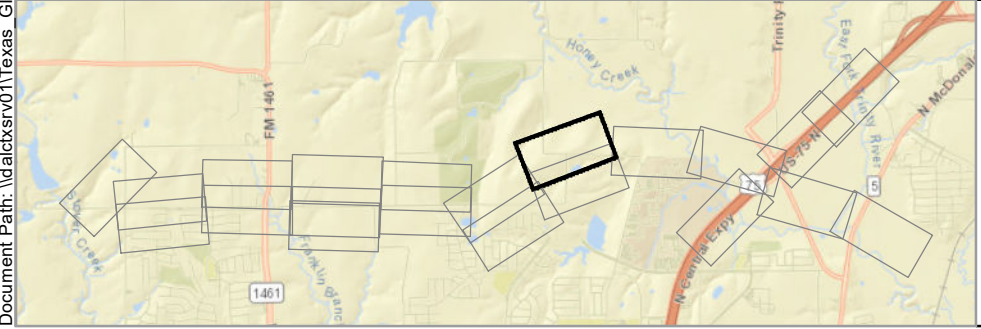
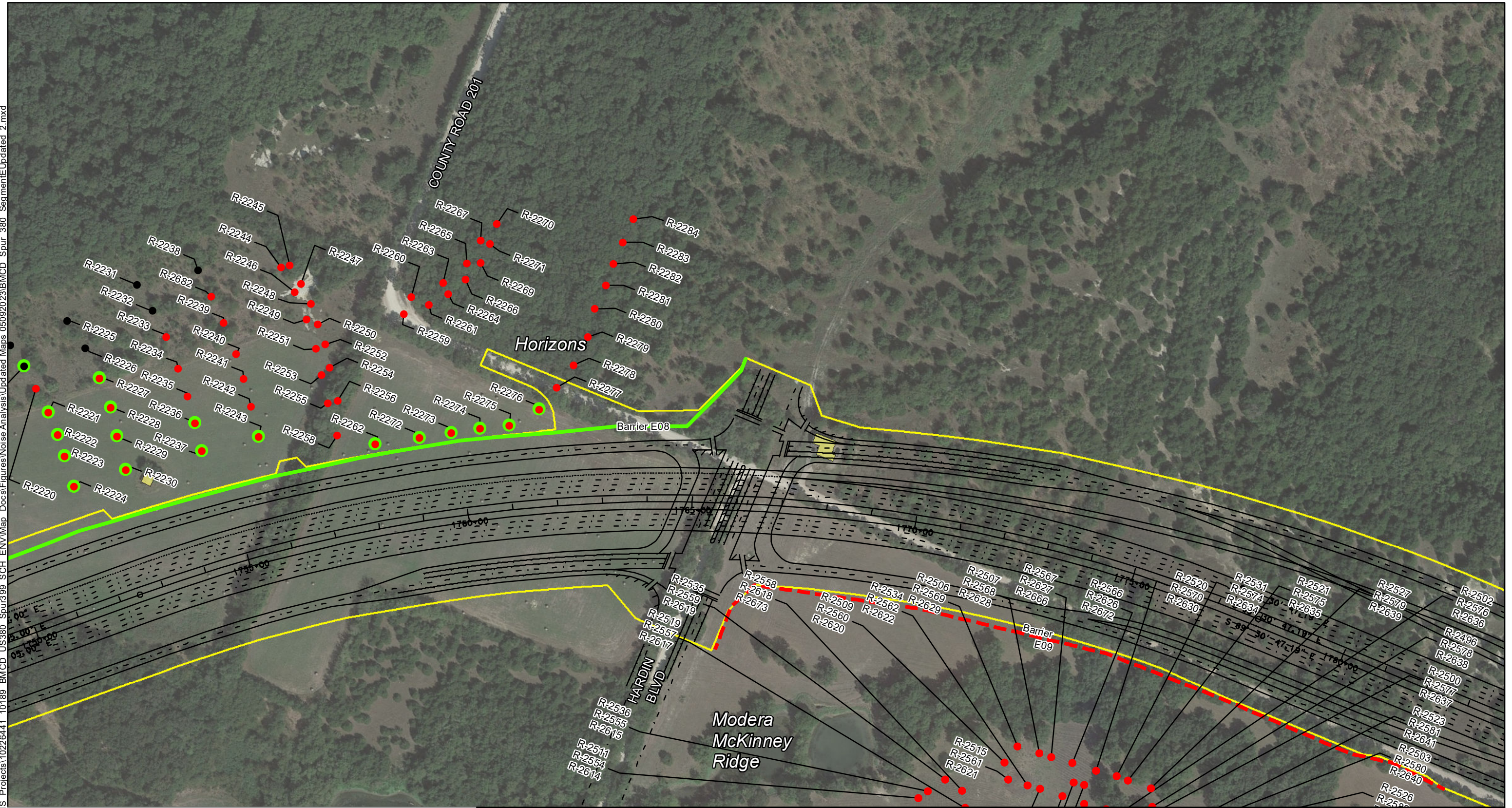
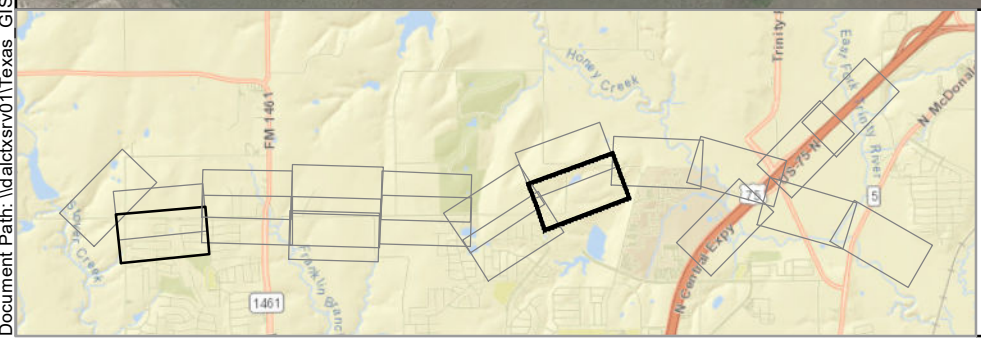
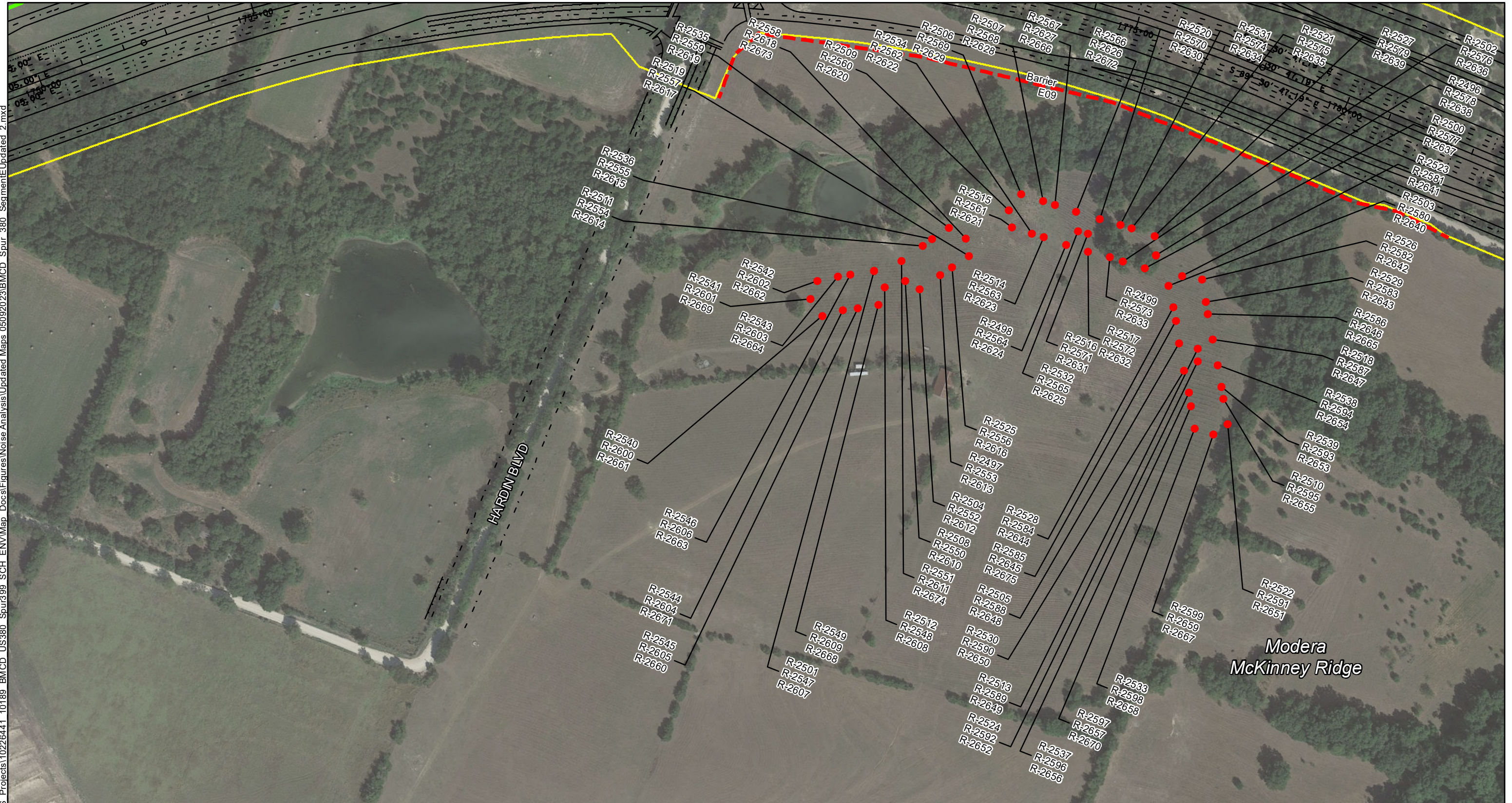


FIGURE E-11
JUNE 2023
















<p>Legend</p> <ul style="list-style-type: none"> — PROPOSED BARRIER - - - BARRIER ANALYZED BUT NOT PROPOSED ● IMPACTED RECEIVER ● NON-IMPACTED RECEIVER ● BENEFITED RECEIVER RESIDENTIAL DISPLACEMENT COMMERCIAL DISPLACEMENT — EXISTING ROW — PROPOSED IMPROVEMENTS — PROPOSED ROW — EXISTING NEIGHBORHOOD WALLS VALIDATION LOCATIONS AMBIENT MEASUREMENT SITES 		<p>NOISE IMPACTS AND RECEIVERS</p> <p>US 380 SEGMENT E</p> <p>0 100 200 Feet</p>	
		<p>FIGURE E-12 JUNE 2023</p>	

Document Path: \\dalctskv01\Texas GIS Projects\10226441_10189_BMCD_US380_Spur399_SCH_ENV\Map_Docs\Figures\Noise Analysis\Updated Maps_06092023\BMCD_Spur_380_SegmentEUpdated_2.mxd




Legend


 PROPOSED BARRIER	 EXISTING ROW
 BARRIER ANALYZED BUT NOT PROPOSED	 PROPOSED IMPROVEMENTS
 IMPACTED RECEIVER	 PROPOSED ROW
 NON-IMPACTED RECEIVER	 EXISTING NEIGHBORHOOD WALLS
 BENEFITED RECEIVER	 VALIDATION LOCATIONS
 RESIDENTIAL DISPLACEMENT	 AMBIENT MEASUREMENT SITES
 COMMERCIAL DISPLACEMENT	

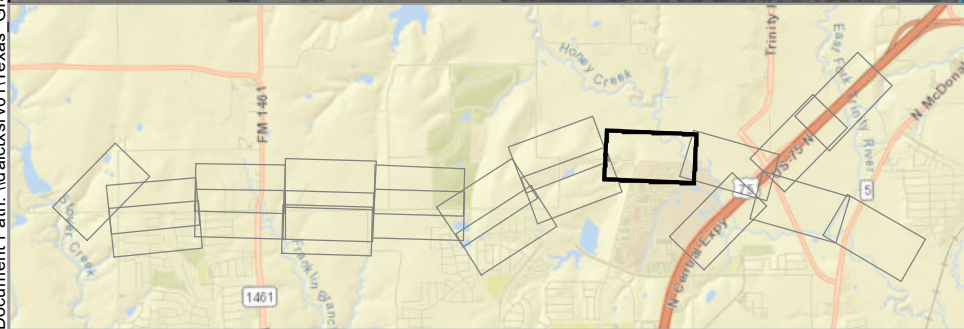
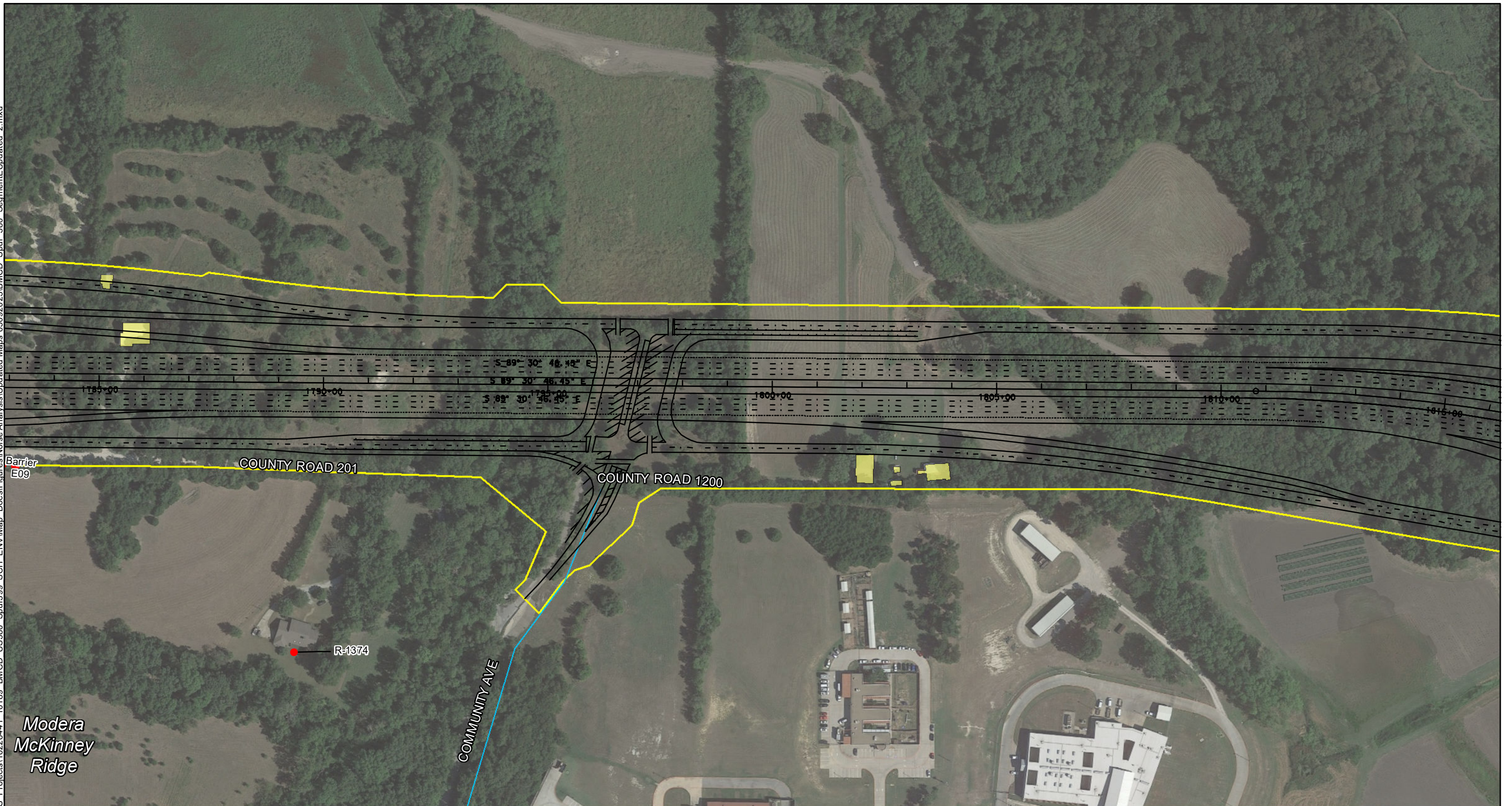
NOISE IMPACTS AND RECEIVERS

US 380
SEGMENT E

0 100 200 Feet



 **FIGURE E-13**
JUNE 2023



Legend

- PROPOSED BARRIER
- - - BARRIER ANALYZED BUT NOT PROPOSED
- IMPACTED RECEIVER
- NON-IMPACTED RECEIVER
- BENEFITED RECEIVER
- RESIDENTIAL DISPLACEMENT
- COMMERCIAL DISPLACEMENT
- EXISTING ROW
- PROPOSED IMPROVEMENTS
- PROPOSED ROW
- EXISTING NEIGHBORHOOD WALLS
- VALIDATION LOCATIONS
- AMBIENT MEASUREMENT SITES

NOISE IMPACTS AND RECEIVERS

US 380
SEGMENT E

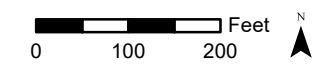
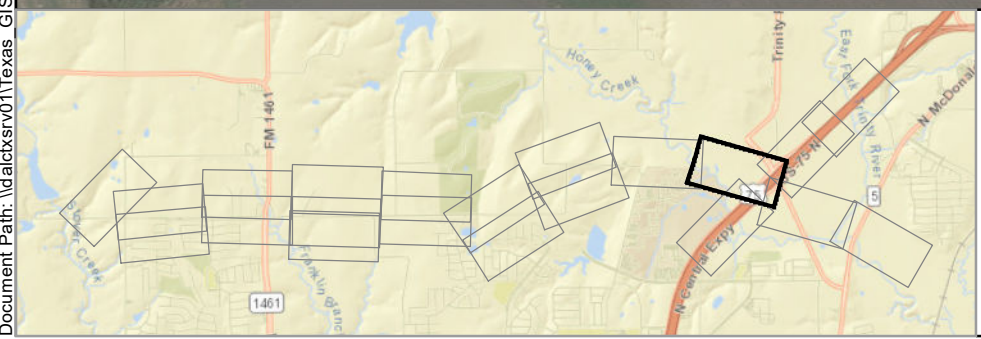


FIGURE E-14
JUNE 2023



Legend

PROPOSED BARRIER	EXISTING ROW
BARRIER ANALYZED BUT NOT PROPOSED	PROPOSED IMPROVEMENTS
IMPACTED RECEIVER	PROPOSED ROW
NON-IMPACTED RECEIVER	EXISTING NEIGHBORHOOD WALLS
BENEFITED RECEIVER	VALIDATION LOCATIONS
RESIDENTIAL DISPLACEMENT	AMBIENT MEASUREMENT SITES
COMMERCIAL DISPLACEMENT	

NOISE IMPACTS AND RECEIVERS

US 380
SEGMENT E

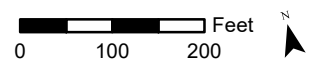
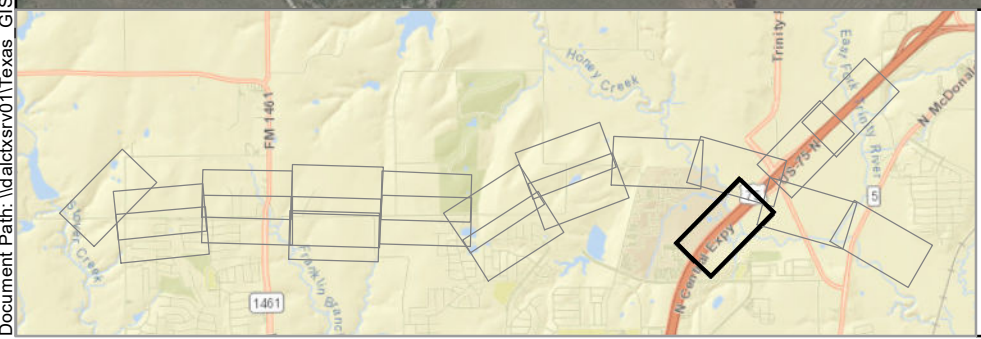
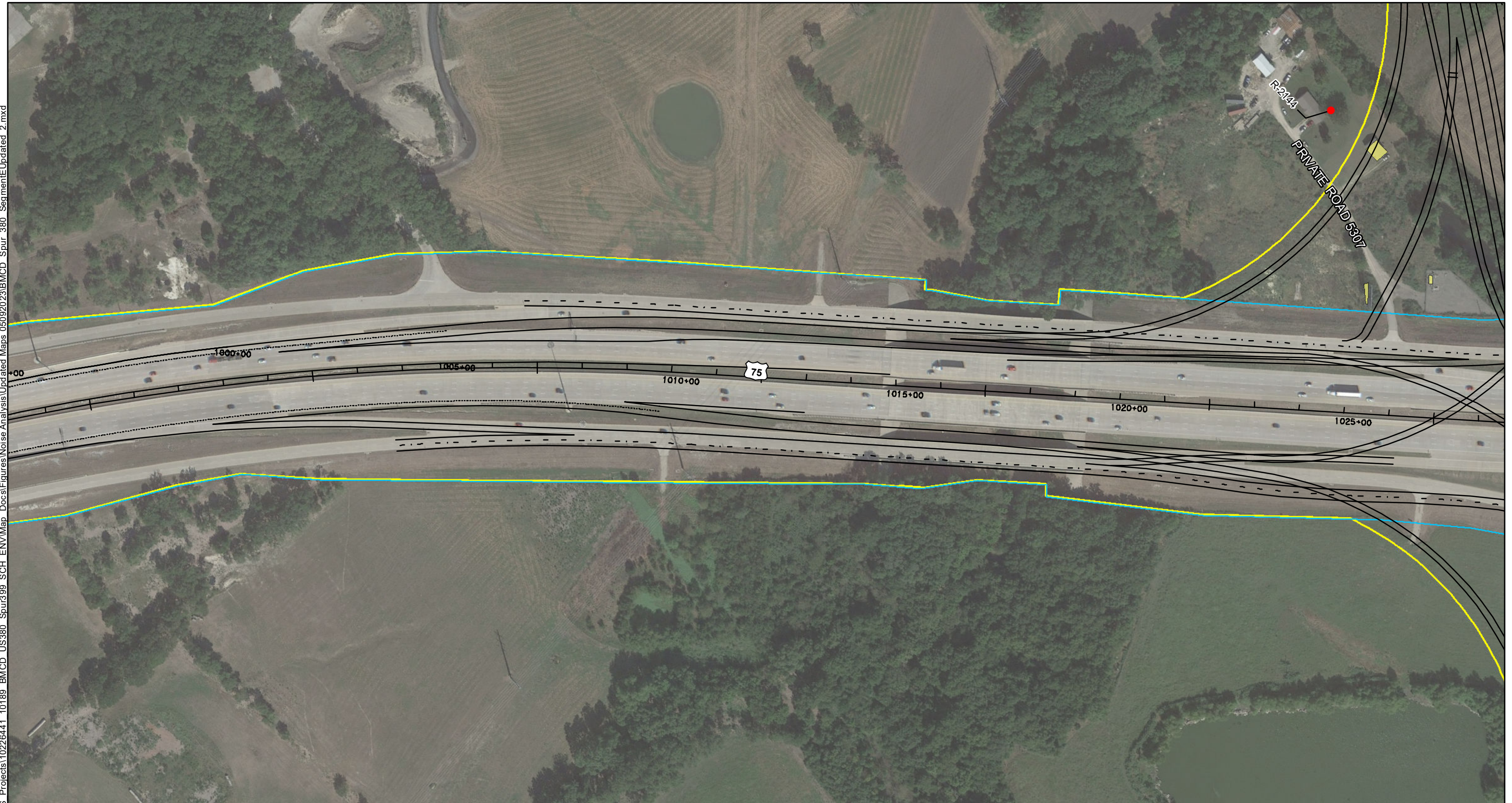


FIGURE E-15
JUNE 2023



Legend

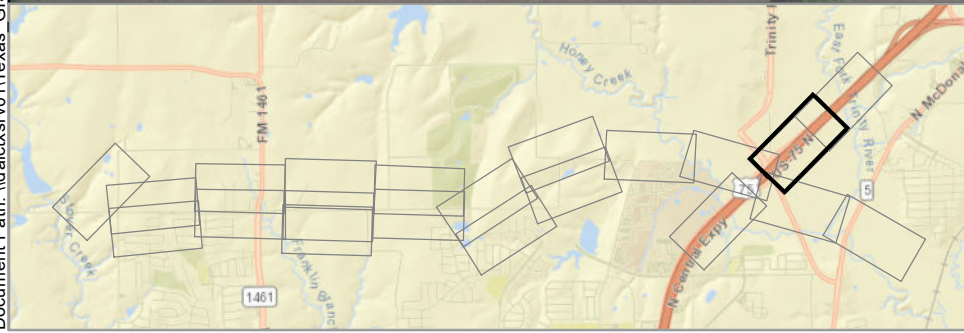
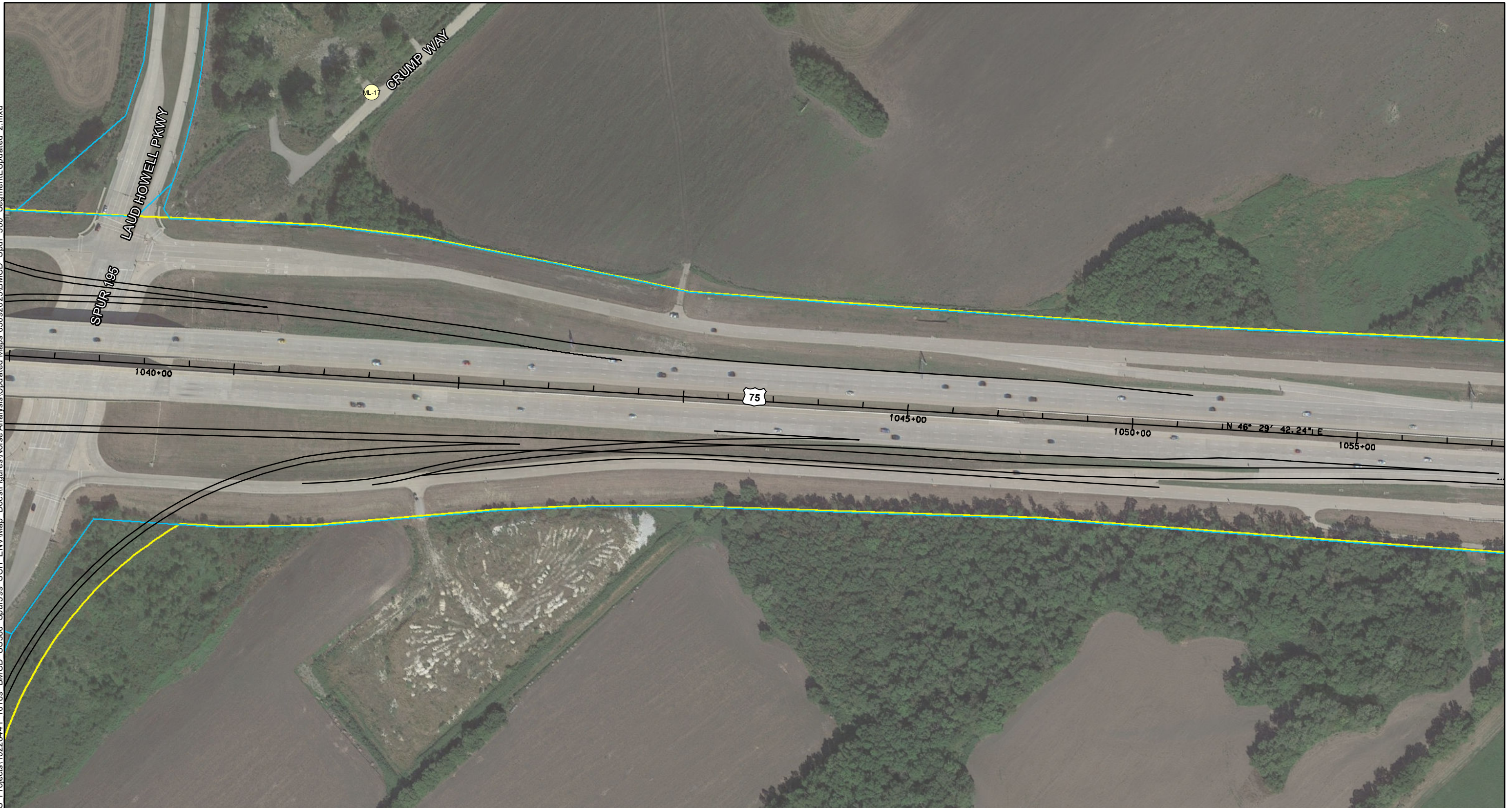
PROPOSED BARRIER	EXISTING ROW
BARRIER ANALYZED BUT NOT PROPOSED	PROPOSED IMPROVEMENTS
IMPACTED RECEIVER	PROPOSED ROW
NON-IMPACTED RECEIVER	EXISTING NEIGHBORHOOD WALLS
BENEFITED RECEIVER	VALIDATION LOCATIONS
RESIDENTIAL DISPLACEMENT	AMBIENT MEASUREMENT SITES
COMMERCIAL DISPLACEMENT	

NOISE IMPACTS AND RECEIVERS

US 380
SEGMENT E

0 100 200 Feet

FIGURE E-16
JUNE 2023



Legend

- PROPOSED BARRIER
- - - BARRIER ANALYZED BUT NOT PROPOSED
- IMPACTED RECEIVER
- NON-IMPACTED RECEIVER
- BENEFITED RECEIVER
- RESIDENTIAL DISPLACEMENT
- COMMERCIAL DISPLACEMENT
- EXISTING ROW
- PROPOSED IMPROVEMENTS
- PROPOSED ROW
- EXISTING NEIGHBORHOOD WALLS
- VALIDATION LOCATIONS
- AMBIENT MEASUREMENT SITES

NOISE IMPACTS AND RECEIVERS

US 380
SEGMENT E

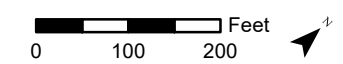
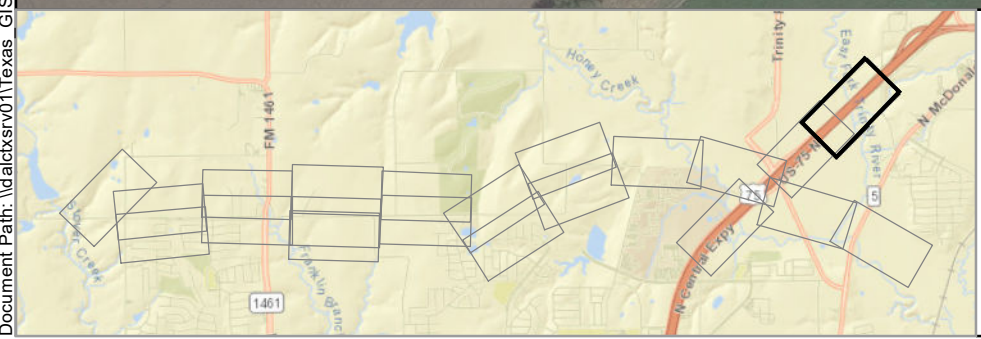
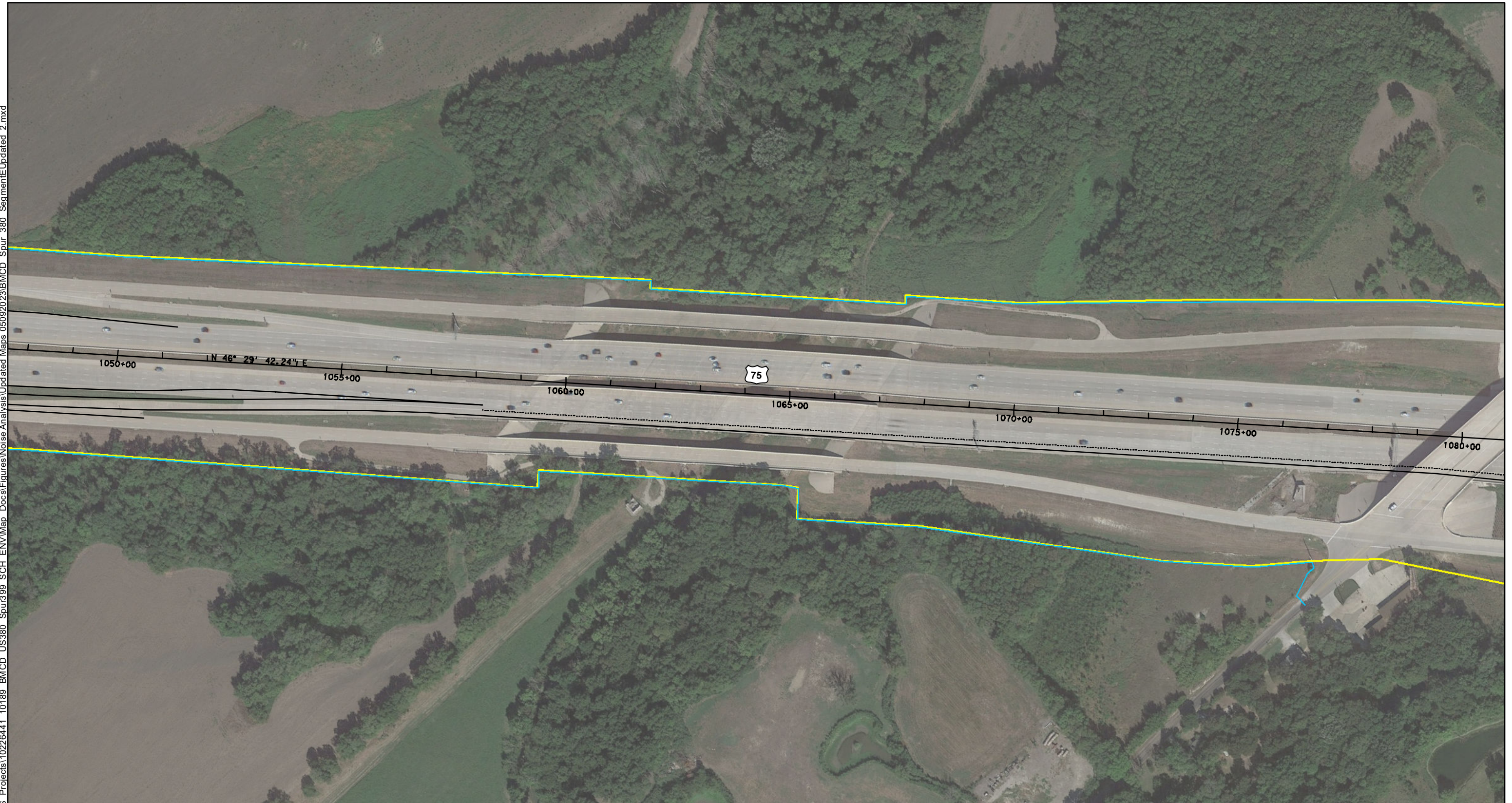


FIGURE E-17
JUNE 2023



Legend

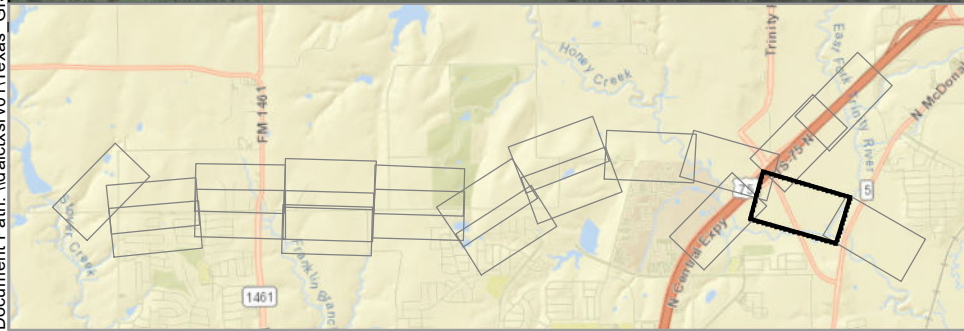
PROPOSED BARRIER	EXISTING ROW
BARRIER ANALYZED BUT NOT PROPOSED	PROPOSED IMPROVEMENTS
IMPACTED RECEIVER	PROPOSED ROW
NON-IMPACTED RECEIVER	EXISTING NEIGHBORHOOD WALLS
BENEFITED RECEIVER	VALIDATION LOCATIONS
RESIDENTIAL DISPLACEMENT	AMBIENT MEASUREMENT SITES
COMMERCIAL DISPLACEMENT	

NOISE IMPACTS AND RECEIVERS

US 380
SEGMENT E

0 100 200 Feet

FIGURE E-18
JUNE 2023



Legend

- PROPOSED BARRIER
- - - BARRIER ANALYZED BUT NOT PROPOSED
- IMPACTED RECEIVER
- NON-IMPACTED RECEIVER
- BENEFITED RECEIVER
- RESIDENTIAL DISPLACEMENT
- COMMERCIAL DISPLACEMENT
- EXISTING ROW
- PROPOSED IMPROVEMENTS
- PROPOSED ROW
- EXISTING NEIGHBORHOOD WALLS
- VALIDATION LOCATIONS
- AMBIENT MEASUREMENT SITES

NOISE IMPACTS AND RECEIVERS

US 380
SEGMENT E

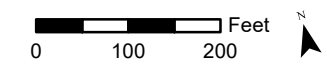
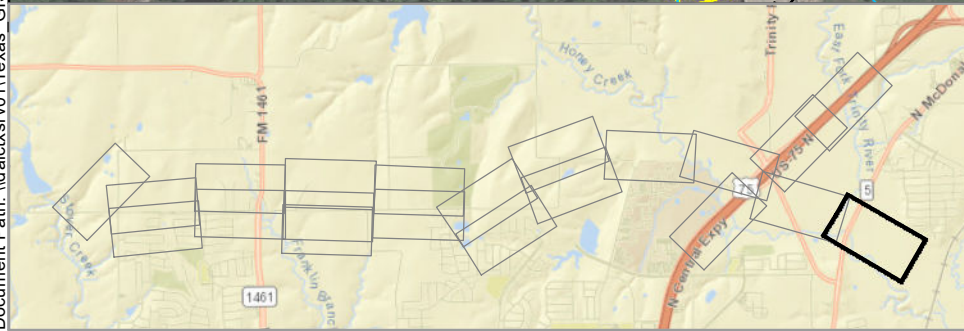
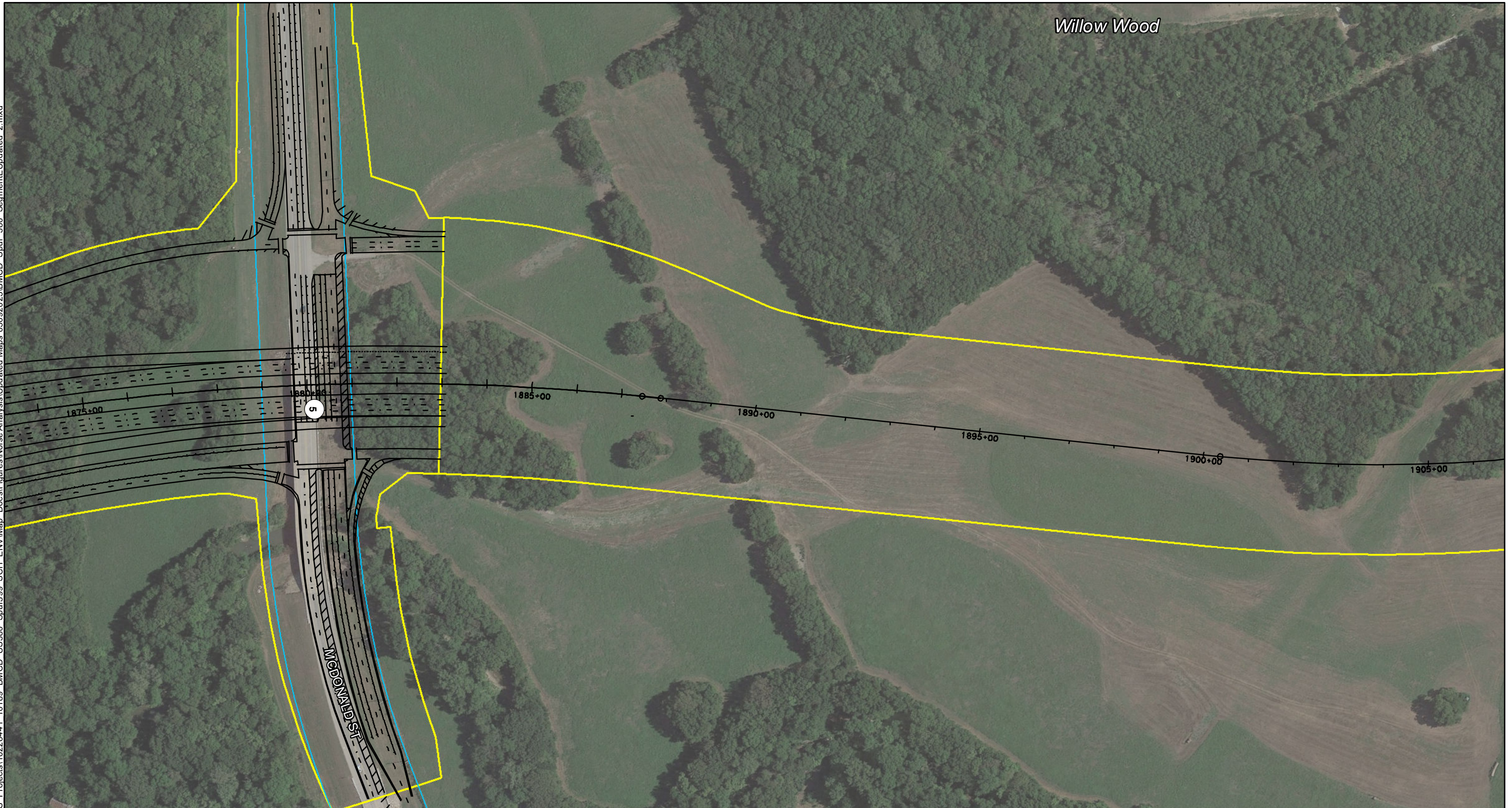


FIGURE E-19
JUNE 2023



Legend

- PROPOSED BARRIER
- - - BARRIER ANALYZED BUT NOT PROPOSED
- IMPACTED RECEIVER
- NON-IMPACTED RECEIVER
- BENEFITED RECEIVER
- RESIDENTIAL DISPLACEMENT
- COMMERCIAL DISPLACEMENT
- EXISTING ROW
- PROPOSED IMPROVEMENTS
- PROPOSED ROW
- EXISTING NEIGHBORHOOD WALLS
- VALIDATION LOCATIONS
- AMBIENT MEASUREMENT SITES

NOISE IMPACTS AND RECEIVERS

US 380
SEGMENT E

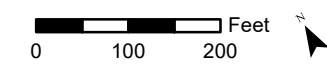


FIGURE E-20
JUNE 2023

Traffic Noise Analysis Report Addendum – Preferred Alternative

Attachment B – Traffic Figures

TRAFFIC ANALYSIS FOR HIGHWAY DESIGN (Option C)

Dallas District

February 15, 2022

										Total Number of Equivalent 18k Single Axle Load Applications One Direction Expected for a 20 Year Period (2030 to 2050)											
Description of Location	Average Daily Traffic		Dir Dist %	K Factor	Percent Trucks		ATHWLD	Percent Tandem Axles in ATHWLD	Flexible Pavement	S N	Rigid Pavement	SLAB									
	2030	2050			ADT	DHV															
	Base Year				Base Year																
<u>US 380 Proposed Mainlanes</u> From Coit Road to FM 1827 Segment A - Section #1 From Coit Road To Exit to Coit Road Collin County										93,000	142,900	58 - 42	8.5	4.9	2.9	12,500	30	17,659,000	3	23,776,000	8"
Data for Use in Air & Noise Analysis																					
Vehicle Class	Base Year																				
	% of ADT		% of DHV																		
Light Duty	95.1		97.1																		
Medium Duty	1.8		1.1																		
Heavy Duty	3.1		1.8																		
										Total Number of Equivalent 18k Single Axle Load Applications One Direction Expected for a 30 Year Period (2030 to 2060)											
Description of Location	Average Daily Traffic		Dir Dist %	K Factor	Percent Trucks		ATHWLD	Percent Tandem Axles in ATHWLD	Flexible Pavement	S N	Rigid Pavement	SLAB									
	2030	2060			ADT	DHV															
	Base Year				Base Year																
<u>US 380 Proposed Mainlanes</u> From Coit Road to FM 1827 Segment A - Section #1 From Coit Road To Exit to Coit Road Collin County										93,000	162,500	58 - 42	8.5	4.9	2.9	12,600	30	28,689,000	3	38,627,500	8"

NOT INTENDED FOR CONSTRUCTION
 BIDDING OR PERMIT PURPOSES
 Dan Perge, P.E.
 Serial Number 77159

TRAFFIC ANALYSIS FOR HIGHWAY DESIGN (Option C)

Dallas District

February 15, 2022

										Total Number of Equivalent 18k Single Axle Load Applications One Direction Expected for a 20 Year Period (2030 to 2050)													
Description of Location	Average Daily Traffic		Dir Dist %	K Factor	Base Year Percent Trucks		ATHWLD	Percent Tandem Axles in ATHWLD	Flexible Pavement	S N	Rigid Pavement	SLAB											
	2030	2050			ADT	DHV																	
<u>US 380 Proposed Mainlanes</u> From Coit Road to FM 1827 Segment A - Section #2 From Exit to Coit Road To Future Bloomdale Road Collin County												75,400	115,900	58 - 42	8.5	5.2	3.1	12,400	40	15,183,500	3	20,452,500	8"
Data for Use in Air & Noise Analysis																							
Vehicle Class	Base Year																						
	% of ADT		% of DHV																				
Light Duty	94.8		96.9																				
Medium Duty	1.9		1.1																				
Heavy Duty	3.3		2.0																				
										Total Number of Equivalent 18k Single Axle Load Applications One Direction Expected for a 30 Year Period (2030 to 2060)													
Description of Location	Average Daily Traffic		Dir Dist %	K Factor	Base Year Percent Trucks		ATHWLD	Percent Tandem Axles in ATHWLD	Flexible Pavement	S N	Rigid Pavement	SLAB											
	2030	2060			ADT	DHV																	
<u>US 380 Proposed Mainlanes</u> From Coit Road to FM 1827 Segment A - Section #2 From Exit to Coit Road To Future Bloomdale Road Collin County												75,400	131,700	58 - 42	8.5	5.2	3.1	12,500	40	24,656,500	3	33,213,000	8"

NOT INTENDED FOR CONSTRUCTION
 BIDDING OR PERMIT PURPOSES
 Dan Perge, P.E.
 Serial Number 77159

TRAFFIC ANALYSIS FOR HIGHWAY DESIGN (Option C)

Dallas District

February 15, 2022

									Total Number of Equivalent 18k Single Axle Load Applications One Direction Expected for a 20 Year Period (2030 to 2050)			
Description of Location	Average Daily Traffic		Dir Dist %	K Factor	Percent Trucks		ATHWLD	Percent Tandem Axles in ATHWLD	Flexible Pavement	S N	Rigid Pavement	SLAB
	2030	2050			ADT	DHV						
	Base Year				Base Year							
Data for Use in Air & Noise Analysis												
Vehicle Class	Base Year											
	% of ADT		% of DHV									
Light Duty	95.1		97.1									
Medium Duty	1.8		1.1									
Heavy Duty	3.1		1.8									
									Total Number of Equivalent 18k Single Axle Load Applications One Direction Expected for a 30 Year Period (2030 to 2060)			
Description of Location	Average Daily Traffic		Dir Dist %	K Factor	Percent Trucks		ATHWLD	Percent Tandem Axles in ATHWLD	Flexible Pavement	S N	Rigid Pavement	SLAB
	2030	2060			ADT	DHV						
	Base Year				Base Year							
<u>US 380 Proposed Mainlanes</u> From Coit Road to FM 1827 Segment B - Section #1 From Coit Road To Exit to Coit Road Collin County	93,000	162,500	58 - 42	8.5	4.9	2.9	12,600	30	28,689,000	3	38,627,500	8"

NOT INTENDED FOR CONSTRUCTION
 BIDDING OR PERMIT PURPOSES
 Dan Perge, P.E.
 Serial Number 77159

TRAFFIC ANALYSIS FOR HIGHWAY DESIGN (Option C)

Dallas District

February 15, 2022

										Total Number of Equivalent 18k Single Axle Load Applications One Direction Expected for a 20 Year Period (2030 to 2050)			
Description of Location	Average Daily Traffic		Dir Dist %	K Factor	Percent Trucks		ATHWLD	Percent Tandem Axles in ATHWLD	Flexible Pavement	S N	Rigid Pavement	SLAB	
	2030	2050			ADT	DHV							
Data for Use in Air & Noise Analysis													
Vehicle Class	Base Year												
	% of ADT		% of DHV										
Light Duty	94.8		96.9										
Medium Duty	1.9		1.1										
Heavy Duty	3.3		2.0										
										Total Number of Equivalent 18k Single Axle Load Applications One Direction Expected for a 30 Year Period (2030 to 2060)			
Description of Location	Average Daily Traffic		Dir Dist %	K Factor	Percent Trucks		ATHWLD	Percent Tandem Axles in ATHWLD	Flexible Pavement	S N	Rigid Pavement	SLAB	
	2030	2060			ADT	DHV							
<u>US 380 Proposed Mainlanes</u> From Coit Road to FM 1827 Segment B - Section #2 From Exit to Coit Road To Future Bloomdale Road West Collin County													
	76,000	133,000	58 - 42	8.5	5.2	3.1	12,500	40	24,882,500	3	33,517,500	8"	

NOT INTENDED FOR CONSTRUCTION
 BIDDING OR PERMIT PURPOSES
 Dan Perge, P.E.
 Serial Number 77159

TRAFFIC ANALYSIS FOR HIGHWAY DESIGN (Option C)

Dallas District

February 15, 2022

										Total Number of Equivalent 18k Single Axle Load Applications One Direction Expected for a 20 Year Period (2030 to 2050)											
Description of Location	Average Daily Traffic		Dir Dist %	K Factor	Percent Trucks		ATHWLD	Percent Tandem Axles in ATHWLD	Flexible Pavement	S N	Rigid Pavement	SLAB									
	2030	2050			ADT	DHV															
	Base Year				Base Year																
<u>US 380 Proposed Mainlanes</u> From Coit Road to FM 1827 Segment C From McDonald Street To FM 1827 Collin County										70,600	109,000	58 - 42	8.5	5.4	3.2	12,400	40	14,795,000	3	19,935,000	8"
Data for Use in Air & Noise Analysis																					
Vehicle Class	Base Year																				
	% of ADT		% of DHV																		
Light Duty	94.6		96.8																		
Medium Duty	1.9		1.1																		
Heavy Duty	3.5		2.1																		
										Total Number of Equivalent 18k Single Axle Load Applications One Direction Expected for a 30 Year Period (2030 to 2060)											
Description of Location	Average Daily Traffic		Dir Dist %	K Factor	Percent Trucks		ATHWLD	Percent Tandem Axles in ATHWLD	Flexible Pavement	S N	Rigid Pavement	SLAB									
	2030	2060			ADT	DHV															
	Base Year				Base Year																
<u>US 380 Proposed Mainlanes</u> From Coit Road to FM 1827 Segment C From McDonald Street To FM 1827 Collin County										70,600	123,200	58 - 42	8.5	5.4	3.2	12,400	40	23,947,500	3	32,267,000	8"

NOT INTENDED FOR CONSTRUCTION
 BIDDING OR PERMIT PURPOSES
 Dan Perge, P.E.
 Serial Number 77159

TRAFFIC ANALYSIS FOR HIGHWAY DESIGN (Option C)

Dallas District

February 15, 2022

										Total Number of Equivalent 18k Single Axle Load Applications One Direction Expected for a 20 Year Period (2030 to 2050)			
Description of Location	Average Daily Traffic		Dir Dist %	K Factor	Base Year Percent Trucks		ATHWLD	Percent Tandem Axles in ATHWLD	Flexible Pavement	S N	Rigid Pavement	SLAB	
	2030	2050			ADT	DHV							
	<u>US 380 Proposed Mainlanes</u> From Coit Road to FM 1827 Segment D From McDonald Street To FM 1827 Collin County												
	84,600	130,900	58 - 42	8.5	5.0	3.0	12,500	40	16,456,000	3	22,160,000	8"	
Data for Use in Air & Noise Analysis													
Vehicle Class	Base Year												
	% of ADT		% of DHV										
Light Duty	95.0		97.0										
Medium Duty	1.8		1.1										
Heavy Duty	3.2		1.9										
										Total Number of Equivalent 18k Single Axle Load Applications One Direction Expected for a 30 Year Period (2030 to 2060)			
Description of Location	Average Daily Traffic		Dir Dist %	K Factor	Base Year Percent Trucks		ATHWLD	Percent Tandem Axles in ATHWLD	Flexible Pavement	S N	Rigid Pavement	SLAB	
	2030	2060			ADT	DHV							
	<u>US 380 Proposed Mainlanes</u> From Coit Road to FM 1827 Segment D From McDonald Street To FM 1827 Collin County												
	84,600	147,100	58 - 42	8.5	5.0	3.0	12,500	30	26,539,500	3	35,739,000	8"	

NOT INTENDED FOR CONSTRUCTION
 BIDDING OR PERMIT PURPOSES
 Dan Perge, P.E.
 Serial Number 77159

TRAFFIC ANALYSIS FOR HIGHWAY DESIGN (Option C)

Dallas District

February 15, 2022

									Total Number of Equivalent 18k Single Axle Load Applications One Direction Expected for a 20 Year Period (2030 to 2050)			
Description of Location	Average Daily Traffic		Dir Dist %	K Factor	Percent Trucks		ATHWLD	Percent Tandem Axles in ATHWLD	Flexible Pavement	S N	Rigid Pavement	SLAB
	2030	2050			ADT	DHV						
Data for Use in Air & Noise Analysis												
Vehicle Class	Base Year											
	% of ADT	% of DHV										
Light Duty	95.1	97.1										
Medium Duty	1.8	1.1										
Heavy Duty	3.1	1.8										
									Total Number of Equivalent 18k Single Axle Load Applications One Direction Expected for a 30 Year Period (2030 to 2060)			
Description of Location	Average Daily Traffic		Dir Dist %	K Factor	Percent Trucks		ATHWLD	Percent Tandem Axles in ATHWLD	Flexible Pavement	S N	Rigid Pavement	SLAB
	2030	2060			ADT	DHV						
<u>US 380 Proposed Mainlanes</u> From Coit Road to FM 1827												
Segment E From Future Bloomdale Road To McDonald Street Collin County												
89,600	155,800	58 - 42	8.5	4.9	2.9	12,600	30	27,555,000	3	37,100,500	8"	

NOT INTENDED FOR CONSTRUCTION
 BIDDING OR PERMIT PURPOSES
 Dan Perge, P.E.
 Serial Number 77159

TRAFFIC ANALYSIS FOR HIGHWAY DESIGN (Option C)

Dallas District

February 15, 2022

									Total Number of Equivalent 18k Single Axle Load Applications One Direction Expected for a 20 Year Period (2030 to 2050)			
Description of Location	Average Daily Traffic		Dir Dist %	K Factor	Percent Trucks		ATHWLD	Percent Tandem Axles in ATHWLD	Flexible Pavement	S N	Rigid Pavement	SLAB
	2030	2050			ADT	DHV						
	Base Year				Base Year							
Data for Use in Air & Noise Analysis												
Vehicle Class	Base Year											
	% of ADT	% of DHV										
Light Duty	96.3		97.2									
Medium Duty	1.3		1.0									
Heavy Duty	2.4		1.8									
									Total Number of Equivalent 18k Single Axle Load Applications One Direction Expected for a 30 Year Period (2030 to 2060)			
Description of Location	Average Daily Traffic		Dir Dist %	K Factor	Percent Trucks		ATHWLD	Percent Tandem Axles in ATHWLD	Flexible Pavement	S N	Rigid Pavement	SLAB
	2030	2060			ADT	DHV						
	Base Year				Base Year							
<u>US 380 Proposed Frontage Roads</u> From Coit Road to FM 1827 Segment A From Coit Road To Future Bloomdale Road Collin County	30,000	45,900	58 - 42	8.5	3.7	2.8	11,400	30	3,321,500	3	4,057,000	8"
<u>US 380 Proposed Frontage Roads</u> From Coit Road to FM 1827 Segment A From Coit Road To Future Bloomdale Road Collin County	30,000	53,000	58 - 42	8.5	3.7	2.8	11,500	30	5,448,000	3	6,655,000	8"

NOT INTENDED FOR CONSTRUCTION
BIDDING OR PERMIT PURPOSES
Dan Perge, P.E.
Serial Number 77159

TRAFFIC ANALYSIS FOR HIGHWAY DESIGN (Option C)

Dallas District

February 15, 2022

									Total Number of Equivalent 18k Single Axle Load Applications One Direction Expected for a 20 Year Period (2030 to 2050)			
Description of Location	Average Daily Traffic		Dir Dist %	K Factor	Percent Trucks		ATHWLD	Percent Tandem Axles in ATHWLD	Flexible Pavement	S N	Rigid Pavement	SLAB
	2030	2050			ADT	DHV						
	Base Year				Base Year							
Data for Use in Air & Noise Analysis												
Vehicle Class	Base Year											
	% of ADT		% of DHV									
Light Duty	96.3		97.2									
Medium Duty	1.3		1.0									
Heavy Duty	2.4		1.8									
									Total Number of Equivalent 18k Single Axle Load Applications One Direction Expected for a 30 Year Period (2030 to 2060)			
Description of Location	Average Daily Traffic		Dir Dist %	K Factor	Percent Trucks		ATHWLD	Percent Tandem Axles in ATHWLD	Flexible Pavement	S N	Rigid Pavement	SLAB
	2030	2060			ADT	DHV						
	Base Year				Base Year							
<u>US 380 Proposed Frontage Roads</u> From Coit Road to FM 1827 Segment B From Coit Road To Future Bloomdale Road Collin County	21,900	37,900	58 - 42	8.5	3.7	2.8	11,200	40	3,925,500	3	4,795,000	8"

NOT INTENDED FOR CONSTRUCTION
 BIDDING OR PERMIT PURPOSES
 Dan Perge, P.E.
 Serial Number 77159

TRAFFIC ANALYSIS FOR HIGHWAY DESIGN (Option C)

Dallas District

February 15, 2022

										Total Number of Equivalent 18k Single Axle Load Applications One Direction Expected for a 20 Year Period (2030 to 2050)			
Description of Location	Average Daily Traffic		Dir Dist %	K Factor	Percent Trucks		ATHWLD	Percent Tandem Axles in ATHWLD	Flexible Pavement	S N	Rigid Pavement	SLAB	
	Base Year				Trucks								
	2030	2050			ADT	DHV							
Data for Use in Air & Noise Analysis													
Vehicle Class	Base Year												
	% of ADT		% of DHV										
Light Duty	96.3		97.2										
Medium Duty	1.3		1.0										
Heavy Duty	2.4		1.8										
										Total Number of Equivalent 18k Single Axle Load Applications One Direction Expected for a 30 Year Period (2030 to 2060)			
Description of Location	Average Daily Traffic		Dir Dist %	K Factor	Percent Trucks		ATHWLD	Percent Tandem Axles in ATHWLD	Flexible Pavement	S N	Rigid Pavement	SLAB	
	Base Year				Trucks								
	2030	2060			ADT	DHV							
<u>US 380 Proposed Frontage Roads</u> From Coit Road to FM 1827 Segment C From McDonald Street To FM 1827 Collin County	21,700	32,300	58 - 42	8.5	3.7	2.8	11,100	40	2,363,000	3	2,886,500	8"	
<u>US 380 Proposed Frontage Roads</u> From Coit Road to FM 1827 Segment C From McDonald Street To FM 1827 Collin County	21,700	37,300	58 - 42	8.5	3.7	2.8	11,200	40	3,873,000	3	4,730,500	8"	

NOT INTENDED FOR CONSTRUCTION
BIDDING OR PERMIT PURPOSES
Dan Perge, P.E.
Serial Number 77159

TRAFFIC ANALYSIS FOR HIGHWAY DESIGN (Option C)

Dallas District

February 15, 2022

										Total Number of Equivalent 18k Single Axle Load Applications One Direction Expected for a 20 Year Period (2030 to 2050)			
Description of Location	Average Daily Traffic		Dir Dist %	K Factor	Percent Trucks		ATHWLD	Percent Tandem Axles in ATHWLD	Flexible Pavement	S N	Rigid Pavement	SLAB	
	2030	2050			ADT	DHV							
	Base Year				Base Year								
Data for Use in Air & Noise Analysis													
Vehicle Class	Base Year												
	% of ADT		% of DHV										
Light Duty	94.2		95.6										
Medium Duty	2.1		1.6										
Heavy Duty	3.7		2.8										
										Total Number of Equivalent 18k Single Axle Load Applications One Direction Expected for a 30 Year Period (2030 to 2060)			
Description of Location	Average Daily Traffic		Dir Dist %	K Factor	Percent Trucks		ATHWLD	Percent Tandem Axles in ATHWLD	Flexible Pavement	S N	Rigid Pavement	SLAB	
	2030	2060			ADT	DHV							
	Base Year				Base Year								
<u>US 380 Proposed Frontage Roads</u> From Coit Road to FM 1827 Segment D (Section #1) From McDonald Street To Entrance From Airport Drive Collin County	6,900	12,000	58 - 42	8.5	5.8	4.4	10,800	40	1,926,000	3	2,363,000	8"	

NOT INTENDED FOR CONSTRUCTION
 BIDDING OR PERMIT PURPOSES
 Dan Perge, P.E.
 Serial Number 77159

TRAFFIC ANALYSIS FOR HIGHWAY DESIGN (Option C)

Dallas District

February 15, 2022

										Total Number of Equivalent 18k Single Axle Load Applications One Direction Expected for a 20 Year Period (2030 to 2050)											
Description of Location	Average Daily Traffic		Dir Dist %	K Factor	Percent Trucks		ATHWLD	Percent Tandem Axles in ATHWLD	Flexible Pavement	S N	Rigid Pavement	SLAB									
	2030	2050			ADT	DHV															
	Base Year				Base Year																
US 380 Proposed Frontage Roads From Coit Road to FM 1827																					
<u>Segment D (Section #2)</u> From Entrance From Airport Drive To FM 1827										25,100	37,600	58 - 42	8.5	3.6	2.7	11,200	40	2,671,500	3	3,262,000	8"
Collin County																					
Data for Use in Air & Noise Analysis																					
Vehicle Class	Base Year																				
	% of ADT		% of DHV																		
Light Duty	96.4		97.3																		
Medium Duty	1.3		1.0																		
Heavy Duty	2.3		1.7																		
										Total Number of Equivalent 18k Single Axle Load Applications One Direction Expected for a 30 Year Period (2030 to 2060)											
Description of Location	Average Daily Traffic		Dir Dist %	K Factor	Percent Trucks		ATHWLD	Percent Tandem Axles in ATHWLD	Flexible Pavement	S N	Rigid Pavement	SLAB									
	2030	2060			ADT	DHV															
	Base Year				Base Year																
US 380 Proposed Frontage Roads From Coit Road to FM 1827																					
<u>Segment D (Section #2)</u> From Entrance From Airport Drive To FM 1827										25,100	43,000	58 - 42	8.5	3.6	2.7	11,300	30	4,352,500	3	5,315,000	8"
Collin County																					

NOT INTENDED FOR CONSTRUCTION
 BIDDING OR PERMIT PURPOSES
 Dan Perge, P.E.
 Serial Number 77159

TRAFFIC ANALYSIS FOR HIGHWAY DESIGN (Option C)

Dallas District

February 15, 2022

										Total Number of Equivalent 18k Single Axle Load Applications One Direction Expected for a 20 Year Period (2030 to 2050)											
Description of Location	Average Daily Traffic		Dir Dist %	K Factor	Percent Trucks		ATHWLD	Percent Tandem Axles in ATHWLD	Flexible Pavement	S N	Rigid Pavement	SLAB									
	2030	2050			ADT	DHV															
	Base Year				Base Year																
US 380 Proposed Frontage Roads From Coit Road to FM 1827																					
<u>Segment E</u> From Future Bloomdale Road To McDonald Street										30,700	47,500	58 - 42	8.5	3.6	2.7	11,400	30	3,332,000	3	4,068,500	8"
Collin County																					
Data for Use in Air & Noise Analysis																					
Vehicle Class	Base Year																				
	% of ADT		% of DHV																		
Light Duty	96.4		97.3																		
Medium Duty	1.3		1.0																		
Heavy Duty	2.3		1.7																		
										Total Number of Equivalent 18k Single Axle Load Applications One Direction Expected for a 30 Year Period (2030 to 2060)											
Description of Location	Average Daily Traffic		Dir Dist %	K Factor	Percent Trucks		ATHWLD	Percent Tandem Axles in ATHWLD	Flexible Pavement	S N	Rigid Pavement	SLAB									
	2030	2060			ADT	DHV															
	Base Year				Base Year																
US 380 Proposed Frontage Roads From Coit Road to FM 1827																					
<u>Segment E</u> From Future Bloomdale Road To McDonald Street										30,700	53,700	58 - 42	8.5	3.6	2.7	11,500	30	5,394,500	3	6,587,000	8"
Collin County																					

NOT INTENDED FOR CONSTRUCTION
 BIDDING OR PERMIT PURPOSES
 Dan Perge, P.E.
 Serial Number 77159

1 Coit Rd @ US 380

Year	2020
ADT	9300
K-factor	9.4
D-factor	52
Truck%	6.4
SingleUnit'	4.7
ComboUni	1.7

Year	2020
ADT	42900
K-factor	8.5
D-factor	55
Truck%	7.5
SingleUnit'	3.7
ComboUni	3.8

Year	2020
ADT	45700
K-factor	8.5
D-factor	55
Truck%	7.5
SingleUnit'	3.7
ComboUni	3.8

Year	2020
ADT	12100
K-factor	16.4
D-factor	65
Truck%	3.2
SingleUnit'	1.8
ComboUni	1.4

2 Prestwick Hollow Dr @ US 380

Year	2020
ADT	48000
K-factor	8.5
D-factor	55
Truck%	7.5
SingleUnit'	3.7
ComboUni	3.8

Year	2020
ADT	42900
K-factor	8.5
D-factor	55
Truck%	7.5
SingleUnit'	3.7
ComboUni	3.8

Year	2020
ADT	1100
K-factor	14
D-factor	60
Truck%	3.2
SingleUnit'	1.8
ComboUni	1.4

3 Lakewood Dr @ US 380

Year	2020
ADT	800
K-factor	8.5
D-factor	55
Truck%	7.5
SingleUnit'	3.7
ComboUni	3.8

Year	2020
ADT	48000
K-factor	8.5
D-factor	55
Truck%	7.5
SingleUnit'	3.7
ComboUni	3.8

Year	2020
ADT	48000
K-factor	8.5
D-factor	55
Truck%	7.5
SingleUnit'	3.7
ComboUni	3.8

4 Custer Rd @ US 380

Year	2020
ADT	13900
K-factor	8.2
D-factor	52
Truck%	3.7
SingleUnit'	2.6
ComboUni	1.1

Year	2020
ADT	43800
K-factor	8.6
D-factor	53
Truck%	6.5
SingleUnit'	3.3
ComboUni	3.2

Year	2020
ADT	41400
K-factor	8.5
D-factor	55
Truck%	7.5
SingleUnit'	3.7
ComboUni	3.8

Year	2020
ADT	23000
K-factor	8.5
D-factor	51
Truck%	3.7
SingleUnit'	2.5
ComboUni	1.2

5 Stonebridge Dr @ US 380

Year	2020
ADT	40400
K-factor	8.6
D-factor	53
Truck%	6.5
SingleUnit'	3.3
ComboUni	3.2

Year	2020
ADT	43800
K-factor	8.6
D-factor	53
Truck%	6.5
SingleUnit'	3.3
ComboUni	3.2

Year	2020
ADT	7500
K-factor	10.8
D-factor	58
Truck%	3.2
SingleUnit'	1.8
ComboUni	1.4

6 CR 933

Year	2020
ADT	20
K-factor	10.2
D-factor	60
Truck%	3.2
SingleUnit'	1.8
ComboUni	1.4

Year	2020
ADT	20
K-factor	10.2
D-factor	60
Truck%	3.2
SingleUnit'	1.8
ComboUni	1.4

7

Custer Rd @ County Rd

Year	2020
ADT	13900
K-factor	8.2
D-factor	62
Truck%	3.8
SingleUnit'	2.7
ComboUni	1.1

Year	2020
ADT	2700
K-factor	10.9
D-factor	61
Truck%	6
SingleUnit'	3.6
ComboUni	2.4

Year	2020
ADT	13900
K-factor	8.2
D-factor	62
Truck%	3.8
SingleUnit'	2.7
ComboUni	1.1

8

Grassmere Ln @ US 380

Year	2020
ADT	1100
K-factor	10.2
D-factor	60
Truck%	3.2
SingleUnit'	1.8
ComboUni	1.4

Year	2020
ADT	41700
K-factor	8.6
D-factor	53
Truck%	6.5
SingleUnit'	3.3
ComboUni	3.2

Year	2020
ADT	40400
K-factor	8.6
D-factor	53
Truck%	6.5
SingleUnit'	3.3
ComboUni	3.2

Year	2020
ADT	1300
K-factor	10.2
D-factor	60
Truck%	3.2
SingleUnit'	1.8
ComboUni	1.4

Year	2019
ADT	700
K-factor	11.2
D-factor	60
Truck%	3.2
SingleUnit'	1.8
ComboUni	1.4

Year	2019
ADT	700
K-factor	11.2
D-factor	60
Truck%	3.2
SingleUnit'	1.8
ComboUni	1.4

Year	2020
ADT	20
K-factor	11.2
D-factor	60
Truck%	3.2
SingleUnit'	1.8
ComboUni	1.4

Year	2020
ADT	80
K-factor	10.2
D-factor	60
Truck%	3.2
SingleUnit'	1.8
ComboUni	1.4

Year	2020
ADT	2700
K-factor	10.2
D-factor	60
Truck%	3.2
SingleUnit'	1.8
ComboUni	1.4

Year	2020
ADT	2900
K-factor	10.2
D-factor	60
Truck%	3.2
SingleUnit'	1.8
ComboUni	1.4

Year	2020
ADT	400
K-factor	10.2
D-factor	60
Truck%	3.2
SingleUnit'	1.8
ComboUni	1.4

Year	2020
ADT	6900
K-factor	9.7
D-factor	62
Truck%	6.7
SingleUnit'	3.3
ComboUni	3.4

Year	2020
ADT	200
K-factor	10.2
D-factor	60
Truck%	3.2
SingleUnit'	1.8
ComboUni	1.4

Year	2020
ADT	2700
K-factor	10.2
D-factor	60
Truck%	3.2
SingleUnit'	1.8
ComboUni	1.4

Year	2020
ADT	10400
K-factor	8.3
D-factor	50
Truck%	2.8
SingleUnit'	2
ComboUni	0.8

12 CR 164 @ CR 201

Year	2020
ADT	170
K-factor	15
D-factor	60
Truck%	2.9
SingleUnit'	1.7
ComboUni	1.2

Year	2020	Year	2020
ADT	170	ADT	170
K-factor	15	K-factor	10.2
D-factor	60	D-factor	60
Truck%	2.9	Truck%	3.2
SingleUnit'	1.7	SingleUnit'	1.8
ComboUni	1.2	ComboUni	1.4

13 Community Avenue @ CR 201

Year	2020
ADT	170
K-factor	10.2
D-factor	60
Truck%	3.2
SingleUnit'	1.8
ComboUni	1.4

Year	2020	Year	2020
ADT	170	ADT	2700
K-factor	10.2	K-factor	13.3
D-factor	60	D-factor	60
Truck%	3.2	Truck%	3.2
SingleUnit'	1.8	SingleUnit'	1.8
ComboUni	1.4	ComboUni	1.4

14 Bloomdale Rd @ US 75

		US 75 SBFR	US 75 Mainlane	US 75 NBFR	
Year	2020	Year	2020	Year	2020
ADT	5600	ADT	72700	ADT	2600
K-factor	10.8	K-factor	10	K-factor	26.1
D-factor	100	D-factor	66	D-factor	61
Truck%	6.5	Truck%	14	Truck%	3.2
SingleUnit'	4.6	SingleUnit'	3.9	SingleUnit'	1.8
ComboUni	1.9	ComboUni	10.1	ComboUni	1.4
Year 2020		Year 2020		Year 2020	
ADT 3700		ADT 72700		ADT 5600	
K-factor 26.1		K-factor 10		K-factor 10.5	
D-factor 61		D-factor 66		D-factor 100	
Truck% 3.2		Truck% 14		Truck% 6.4	
SingleUnit 1.8		SingleUnit' 3.9		SingleUnit' 4.6	
ComboUni 1.4		ComboUni 10.1		ComboUni 1.9	
US 75 SBFR		US 75 Mainlane		US 75 NBFR	

15 Spur 195 @ US 75

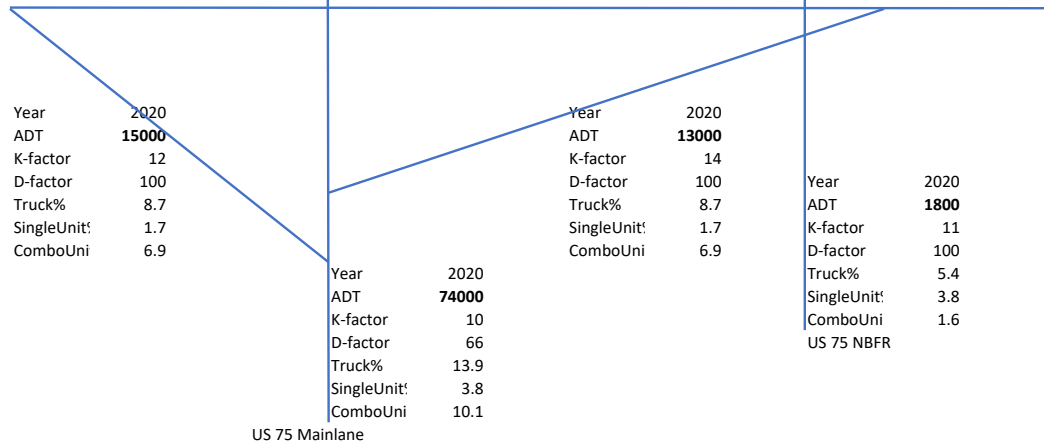
		US 75 SBFR	US 75 Mainlane	US 75 NBFR	
Year	2020	Year	2020	Year	2020
ADT	2300	ADT	72700	ADT	3200
K-factor	10.8	K-factor	10	K-factor	10
D-factor	100	D-factor	66	D-factor	60
Truck%	6.5	Truck%	14	Truck%	8.5
SingleUnit'	4.6	SingleUnit'	3.9	SingleUnit'	7.4
ComboUni	1.9	ComboUni	10.1	ComboUni	1.2
Year 2020		Year 2020		Year 2020	
ADT 11100		ADT 72700		ADT 5600	
K-factor 10.2		K-factor 10		K-factor 10.5	
D-factor 51		D-factor 66		D-factor 100	
Truck% 3.2		Truck% 14		Truck% 6.4	
SingleUnit 1.8		SingleUnit' 3.9		SingleUnit' 4.6	
ComboUni 1.4		ComboUni 10.1		ComboUni 1.9	
US 75 SBFR		US 75 Mainlane		US 75 NBFR	

16 121 @ US 75

US 75 SBFR	
Year	2020
ADT	2200
K-factor	8.2
D-factor	100
Truck%	5.5
SingleUnit [†]	3.9
ComboUni	1.6

US 75 Mainlane	
Year	2020
ADT	51000
K-factor	10
D-factor	66
Truck%	15.3
SingleUnit [†]	3.1
ComboUni	12.2

US 75 NBFR



17 Davis Rd @ US 75

US 75 SBFR	
Year	2020
ADT	2200
K-factor	8.2
D-factor	100
Truck%	5.5
SingleUnit [†]	3.9
ComboUni	1.6

US 75 Mainlane	
Year	2020
ADT	51000
K-factor	10
D-factor	66
Truck%	15.3
SingleUnit [†]	3.1
ComboUni	12.2

US 75 NBFR

US 75 NBFR	
Year	2020
ADT	11300
K-factor	13.5
D-factor	60
Truck%	5.4
SingleUnit [†]	2.7
ComboUni	2.7

US 75 Mainlane	
Year	2020
ADT	51000
K-factor	10
D-factor	66
Truck%	15.3
SingleUnit [†]	3.1
ComboUni	12.2

US 75 NBFR	
Year	2020
ADT	5100
K-factor	10.8
D-factor	60
Truck%	7
SingleUnit [†]	4.9
ComboUni	2

US 75 SBFR

US 75 Mainlane

US 75 NBFR

18

McDonald St (North of Spur 195)

Year	2020
ADT	8200
K-factor	8.5
D-factor	58
Truck%	8.4
SingleUnit%	7.2
ComboUni	1.2

Year	2020
ADT	8200
K-factor	8.5
D-factor	58
Truck%	8.4
SingleUnit%	7.2
ComboUni	1.2

19

CR 338

Year	2020
ADT	480
K-factor	30
D-factor	61
Truck%	5.8
SingleUnit%	3.5
ComboUni	2.3

Year	2020
ADT	480
K-factor	30
D-factor	61
Truck%	5.8
SingleUnit%	3.5
ComboUni	2.3

Year	2020
ADT	3200
K-factor	10.5
D-factor	62
Truck%	10.6
SingleUnit'	3.5
ComboUni	7.1

Year	2020
ADT	2700
K-factor	10.9
D-factor	61
Truck%	6
SingleUnit'	3.6
ComboUni	2.4

Year	2020
ADT	1300
K-factor	10.5
D-factor	62
Truck%	10.6
SingleUnit'	3.5
ComboUni	7.1

Year	2020
ADT	1300
K-factor	11
D-factor	62
Truck%	13.5
SingleUnit'	4.5
ComboUni	9

Year	2020
ADT	10
K-factor	11
D-factor	62
Truck%	13.5
SingleUnit'	4.5
ComboUni	9

Year	2020
ADT	1300
K-factor	11
D-factor	62
Truck%	13.5
SingleUnit'	4.5
ComboUni	9

22 FM 2933 @ CR 335

Year	2020	Year	2020
ADT	1300	ADT	1300
K-factor	11	K-factor	11
D-factor	62	D-factor	62
Truck%	13.5	Truck%	13.5
SingleUnit'	4.5	SingleUnit'	4.5
ComboUni	9	ComboUni	9

Year	2020	Year	2020
ADT	40	ADT	1300
K-factor	17.1	K-factor	11
D-factor	60	D-factor	62
Truck%	2.9	Truck%	13.5
SingleUnit'	2.9	SingleUnit'	4.5
ComboUni	0	ComboUni	9

23 FM 2933 @ CR 332

Year	2020	Year	2020
ADT	1300	ADT	1300
K-factor	11	K-factor	11
D-factor	62	D-factor	62
Truck%	13.5	Truck%	13.5
SingleUnit'	4.5	SingleUnit'	4.5
ComboUni	9	ComboUni	9

Year	2020	Year	2020
ADT	100	ADT	1500
K-factor	10.2	K-factor	11.3
D-factor	60	D-factor	62
Truck%	3.2	Truck%	12.7
SingleUnit'	1.8	SingleUnit'	4.2
ComboUni	1.4	ComboUni	8.5

24 CR 332 @ Peacock Trl

Year	2020
ADT	100
K-factor	10.2
D-factor	60
Truck%	3.2
SingleUnit%	1.8
ComboUni	1.4

25 FM 1827 @ US 380

Year	2020
ADT	5100
K-factor	8.3
D-factor	62
Truck%	5.1
SingleUnit%	3.6
ComboUni	1.5

Year	2020
ADT	40400
K-factor	9.2
D-factor	67
Truck%	4
SingleUnit%	2.5
ComboUni	1.5

Year	2020
ADT	47000
K-factor	8.9
D-factor	61
Truck%	4.5
SingleUnit%	2.8
ComboUni	1.7

26 CR 274

Year	2020
ADT	1800
K-factor	10.9
D-factor	60
Truck%	3.2
SingleUnit%	1.8
ComboUni	1.4

Year	2020
ADT	1800
K-factor	10.9
D-factor	60
Truck%	3.2
SingleUnit%	1.8
ComboUni	1.4

27 Woodlawn Rd

Year	2020
ADT	1200
K-factor	13.3
D-factor	60
Truck%	3.2
SingleUnit%	1.8
ComboUni	1.4

Year	2020
ADT	1200
K-factor	13.3
D-factor	60
Truck%	3.2
SingleUnit%	1.8
ComboUni	1.4

28 Airport Dr @ US 380

Year	2020
ADT	47000
K-factor	8.9
D-factor	61
Truck%	4.5
SingleUnit%	2.8
ComboUni	1.7

Year	2020
ADT	31700
K-factor	8.9
D-factor	61
Truck%	4.5
SingleUnit%	2.8
ComboUni	1.7

Year	2020
ADT	16400
K-factor	8.1
D-factor	60
Truck%	12.9
SingleUnit%	7.3
ComboUni	5.6

29 Privite Road 5092 @ US 380

Year	2020
ADT	40400
K-factor	9.2
D-factor	67
Truck%	4
SingleUnit'	2.5
ComboUni	1.5

Year	2020
ADT	40400
K-factor	9.2
D-factor	67
Truck%	4
SingleUnit'	2.5
ComboUni	1.5

Driveway to McKinney C&D Landfill

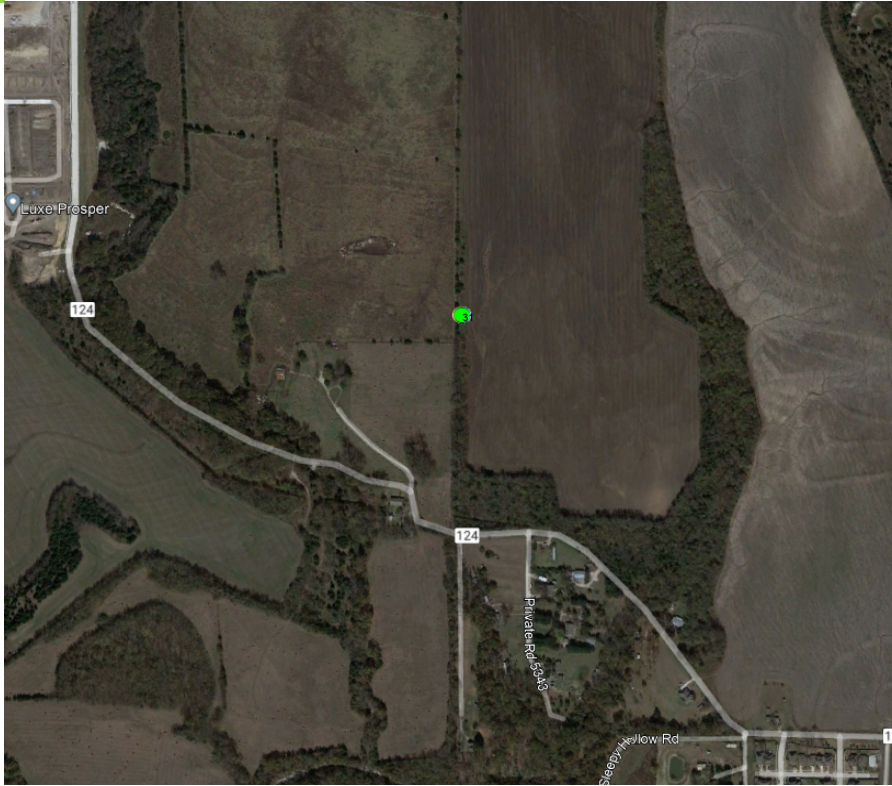
30 Privite Road 5446 @ US 380

Year	2020
ADT	40400
K-factor	9.2
D-factor	67
Truck%	4
SingleUnit'	2.5
ComboUni	1.5

Year	2020
ADT	40400
K-factor	9.2
D-factor	67
Truck%	4
SingleUnit'	2.5
ComboUni	1.5

Year	2020
ADT	300
K-factor	9.2
D-factor	50
Truck%	4
SingleUnit'	2.5
ComboUni	1.5

31 There isn't a road at this location.



32 CR 1006 @ CR 164

Year	2020
ADT	80
K-factor	10.2
D-factor	60
Truck%	3.2
SingleUnit'	1.8
ComboUni	1.4

Year	2020
ADT	500
K-factor	10.3
D-factor	60
Truck%	3.1
SingleUnit'	2.1
ComboUni	1

Year	2020
ADT	500
K-factor	10.3
D-factor	60
Truck%	3.1
SingleUnit'	2.1
ComboUni	1

Year	2020
ADT	500
K-factor	10.2
D-factor	60
Truck%	3.2
SingleUnit'	1.8
ComboUni	1.4

Year	2020
ADT	500
K-factor	10.2
D-factor	60
Truck%	3.2
SingleUnit'	1.8
ComboUni	1.4

a

Red Bud Dr @ University Dr

Year -
 ADT -
 K-factor -
 D-factor -
 Truck% -
 SingleUnit! -
 ComboUni -

Year -
 ADT -
 K-factor -
 D-factor -
 Truck% -
 SingleUnit! -
 ComboUni -

Year	2020
ADT	580
K-factor	9.9
D-factor	60
Truck%	3.2
SingleUnit!	1.8
ComboUni	1.4

b

CR 852 @ University Dr

Year	2020
ADT	200
K-factor	10.2
D-factor	60
Truck%	3.2
SingleUnit!	1.8
ComboUni	1.4

Year -
 ADT -
 K-factor -
 D-factor -
 Truck% -
 SingleUnit! -
 ComboUni -

Year -
 ADT -
 K-factor -
 D-factor -
 Truck% -
 SingleUnit! -
 ComboUni -

c CR 856 @ Univeristy Dr

Year	2020
ADT	170
K-factor	10.2
D-factor	60
Truck%	3.2
SingleUnit!	1.8
ComboUni	1.4

Year	-
ADT	-
K-factor	-
D-factor	-
Truck%	-
SingleUnit!	-
ComboUni	-

Year	-
ADT	-
K-factor	-
D-factor	-
Truck%	-
SingleUnit!	-
ComboUni	-

d Tremont @ University Dr

Year	2020
ADT	2100
K-factor	10.2
D-factor	60
Truck%	3.2
SingleUnit!	1.8
ComboUni	1.4

Year	2020
ADT	40400
K-factor	8.6
D-factor	53
Truck%	6.5
SingleUnit!	3.3
ComboUni	3.2

Year	2020
ADT	40400
K-factor	8.6
D-factor	53
Truck%	6.5
SingleUnit!	3.3
ComboUni	3.2

e Custer Rd @ E. 1st/ Easy Ln
(Same as Point #7)

Year	2020
ADT	13900
K-factor	8.2
D-factor	62
Truck%	3.8
SingleUnit%	2.7
ComboUni	1.1

Year	2020
ADT	100
K-factor	10.2
D-factor	60
Truck%	3.2
SingleUnit%	1.8
ComboUni	1.4

Easy Ln

E. 1st

Year	2020
ADT	2700
K-factor	10.9
D-factor	61
Truck%	6
SingleUnit%	3.6
ComboUni	2.4

Year	2020
ADT	13900
K-factor	8.2
D-factor	62
Truck%	3.8
SingleUnit%	2.7
ComboUni	1.1

All below points volumes are assumed based on ITE Trip Generation. K, D and other factors are assumed from similar points or closet points.

A1 Freedom @ US 380

Year	2020	Year	2020
ADT	41700	ADT	41700
K-factor	8.6	K-factor	8.6
D-factor	53	D-factor	53
Truck%	6.5	Truck%	6.5
SingleUnit%	3.3	SingleUnit%	3.3
ComboUni	3.2	ComboUni	3.2

Year	2020	Year	2020
ADT	800	ADT	800
K-factor	10.8	K-factor	10.8
D-factor	58	D-factor	58
Truck%	3.2	Truck%	3.2
SingleUnit%	1.8	SingleUnit%	1.8
ComboUni	1.4	ComboUni	1.4

A2 Forest Ridge Ln @ US 380

Year	2020	Year	2020
ADT	41700	ADT	41700
K-factor	8.6	K-factor	8.6
D-factor	53	D-factor	53
Truck%	6.5	Truck%	6.5
SingleUnit%	3.3	SingleUnit%	3.3
ComboUni	3.2	ComboUni	3.2

Year	2020	Year	2020
ADT	4200	ADT	4200
K-factor	10.2	K-factor	10.2
D-factor	60	D-factor	60
Truck%	3.2	Truck%	3.2
SingleUnit%	1.8	SingleUnit%	1.8
ComboUni	1.4	ComboUni	1.4

A3 Baneberry Ln @ Bloomdale Rd

Year -
 ADT -
 K-factor -
 D-factor -
 Truck% -
 SingleUnit! -
 ComboUni -

Year	-	Year	2020
ADT	-	ADT	200
K-factor	-	K-factor	10.2
D-factor	-	D-factor	60
Truck%	-	Truck%	3.2
SingleUnit!	-	SingleUnit!	1.8
ComboUni	-	ComboUni	1.4

A4 Bluewood Ln @ Bloomdale Rd

Year -
 ADT -
 K-factor -
 D-factor -
 Truck% -
 SingleUnit! -
 ComboUni -

Year	-	Year	2020
ADT	-	ADT	1600
K-factor	-	K-factor	10.2
D-factor	-	D-factor	60
Truck%	-	Truck%	3.2
SingleUnit!	-	SingleUnit!	1.8
ComboUni	-	ComboUni	1.4

A5 Bluewood Ln @ Grove Cove Dr

Year 2020
 ADT **1600**
 K-factor 10.2
 D-factor 60
 Truck% 3.2
 SingleUnit^s 1.8
 ComboUni 1.4

Year 2020
 ADT **300**
 K-factor 10.2
 D-factor 60
 Truck% 3.2
 SingleUnit^s 1.8
 ComboUni 1.4

Year 2020
 ADT **400**
 K-factor 10.2
 D-factor 60
 Truck% 3.2
 SingleUnit^s 1.8
 ComboUni 1.4

Year 2020
 ADT **1600**
 K-factor 10.2
 D-factor 60
 Truck% 3.2
 SingleUnit^s 1.8
 ComboUni 1.4

A6 CR 943 @ Bloomdale Rd

Year -
 ADT -
 K-factor -
 D-factor -
 Truck% -
 SingleUnit^s -
 ComboUni -

Year -
 ADT -
 K-factor -
 D-factor -
 Truck% -
 SingleUnit^s -
 ComboUni -

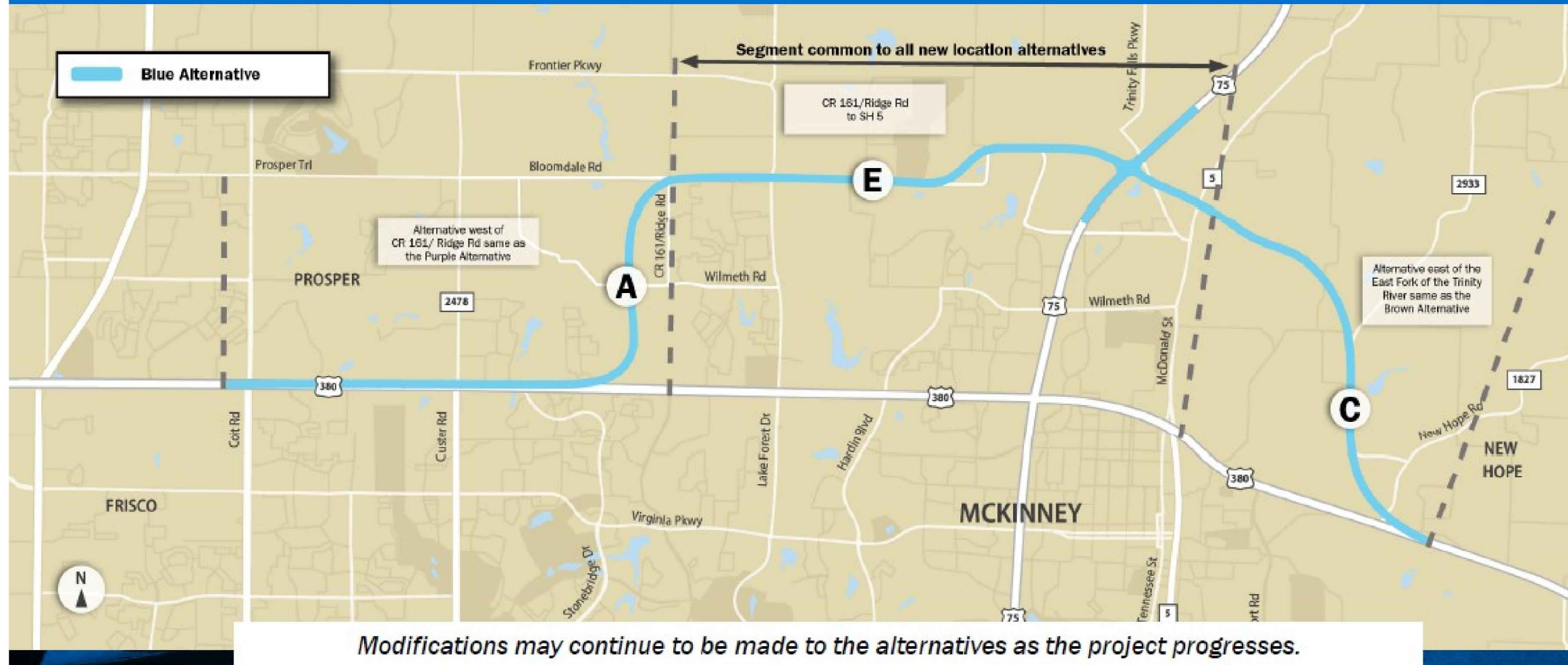
Year 2020
 ADT **400**
 K-factor 10.2
 D-factor 60
 Truck% 3.2
 SingleUnit^s 1.8
 ComboUni 1.4

Year -
ADT -
K-factor -
D-factor -
Truck% -
SingleUnit:-
ComboUni -

Year -
ADT -
K-factor -
D-factor -
Truck% -
SingleUnit:-
ComboUni -

Year 2020
ADT **400**
K-factor 10.2
D-factor 60
Truck% 3.2
SingleUnit: 1.8
ComboUni 1.4

Blue Build Alternative – New Location



US 380 EIS – Coit Road to FM 1827

CSJs: 0135-02-065 and 0135-03-053

January 21, 2021

28

NOT TO SCALE

NOT INTENDED FOR CONSTRUCTION,
BIDDING OR PERMIT PURPOSES
DHURVA LAHON, P.E.
SERIAL NUMBER 102185

US 380 BLUE ALT
KEYMAP

Kimley»Horn
F-928

0135-02-065,
ETC.

SHEET 1 OF 1



COIT ROAD

12,200	↓	11,800
18,800		↑ 18,400
<u>21,300</u>		<u>20,800</u>

3,900
6,200
<u>7,000</u>

39,600
60,400
<u>68,500</u>

3,500
5,500
<u>6,700</u>

47,000
72,100
<u>82,200</u>

WB US 380

47,800
73,100
<u>83,000</u>

WB US 380

3,800	4,300	4,100
5,900	6,500	6,400
<u>6,700</u>	<u>7,100</u>	<u>7,500</u>

EB US 380

46,300
71,400
<u>80,500</u>

3,900
6,100
<u>7,000</u>

38,400
59,100
<u>66,500</u>

4,000
6,200
<u>7,000</u>

4,400	4,000	3,500
6,800	6,100	5,300
<u>7,800</u>	<u>6,800</u>	<u>6,300</u>

EB US 380

46,000
70,800
<u>80,300</u>

SEE SHEET 2 OF 63

NOT TO SCALE

NOT INTENDED FOR CONSTRUCTION,
BIDDING OR PERMIT PURPOSES
DHURVA LAHON, P.E.
SERIAL NUMBER 102185

US 380 BLUE ALT AND
COIT RD
AVERAGE DAILY TRAFFIC
BLUE ALT BUILD VOLUMES

Kimley»Horn
F-928

0135-02-065,
ETC.

SHEET 1 OF 63

LEGEND

- XXXX- 2030 AVERAGE DAILY TRAFFIC VOLUMES
- XXXX- 2050 AVERAGE DAILY TRAFFIC VOLUMES
- XXXX- 2060 AVERAGE DAILY TRAFFIC VOLUMES

DATE: 7/13/2021
FILE: US380_BLUE_TRF_01.dgn



SEE SHEET 1 OF 63

SEE SHEET 3 OF 63

47,000
72,100
82,200

←
 WB US 380

EB US 380

→
 46,000
70,800
80,300

ENTRANCE FROM INDEPENDENCE PARKWAY

←
 47,000
72,100
82,200

→
 46,000
70,800
80,300

EXIT TO INDEPENDENCE PARKWAY

47,000
72,100
82,200

←

WB US 380

EB US 380

→
 46,000
70,800
80,300

NOT TO SCALE

NOT INTENDED FOR CONSTRUCTION,
 BIDDING OR PERMIT PURPOSES
 DHRUVA LAHON, P.E.
 SERIAL NUMBER 102185

US 380 BLUE ALT AND
 RAMPS
 AVERAGE DAILY TRAFFIC
 BLUE ALT BUILD VOLUMES

Kimley»Horn
F-928

0135-02-065,
ETC.

SHEET 2 OF 63

LEGEND

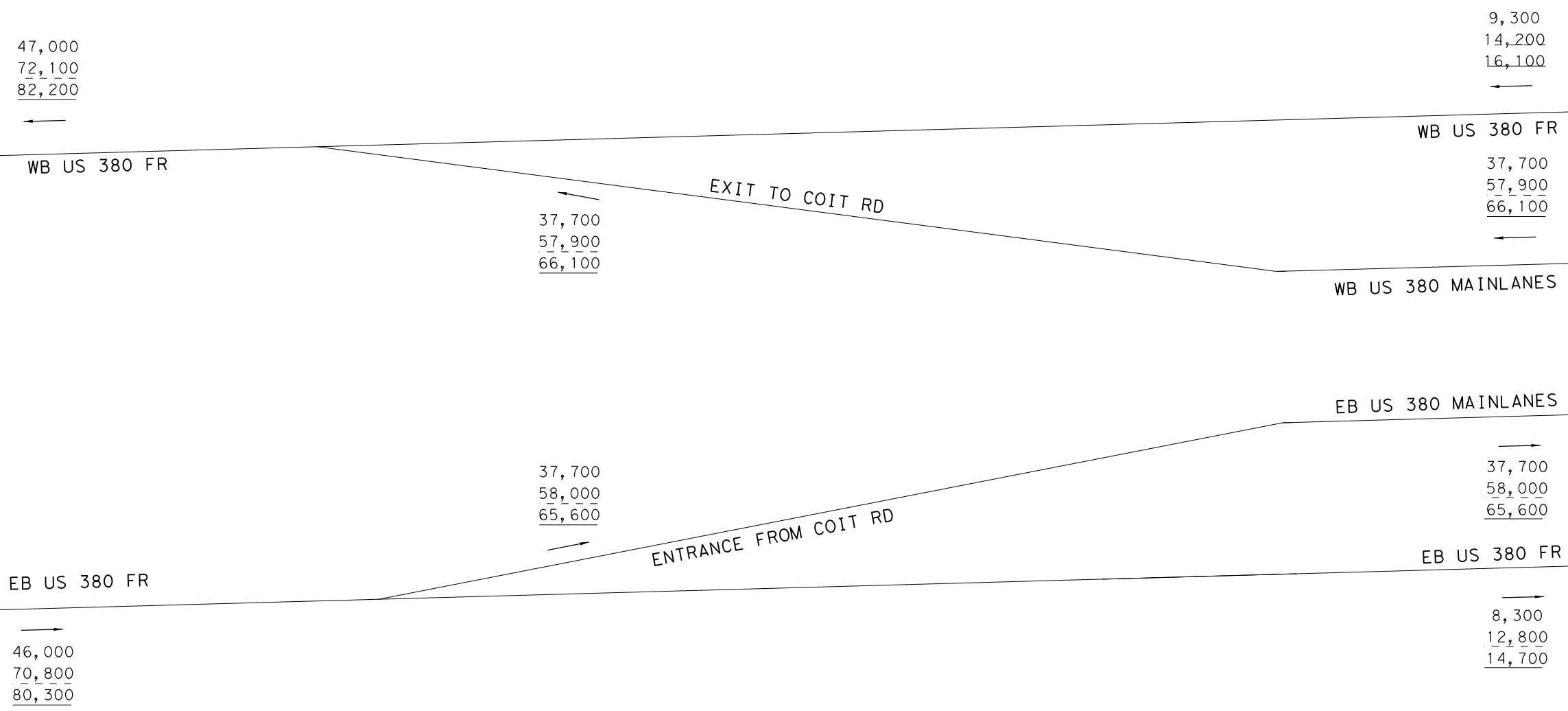
- XXXX- 2030 AVERAGE DAILY TRAFFIC VOLUMES
- XXXX- 2050 AVERAGE DAILY TRAFFIC VOLUMES
- XXXX- 2060 AVERAGE DAILY TRAFFIC VOLUMES

DATE: 7/13/2021
FILE: US380_BLUE_TRF_02.dgn



SEE SHEET 2 OF 63

SEE SHEET 4 OF 63



NOT TO SCALE

NOT INTENDED FOR CONSTRUCTION,
 BIDDING OR PERMIT PURPOSES
 DHRUVA LAHON, P.E.
 SERIAL NUMBER 102185

US 380 BLUE ALT AND
 RAMPS
 AVERAGE DAILY TRAFFIC
 BLUE ALT BUILD VOLUMES



LEGEND

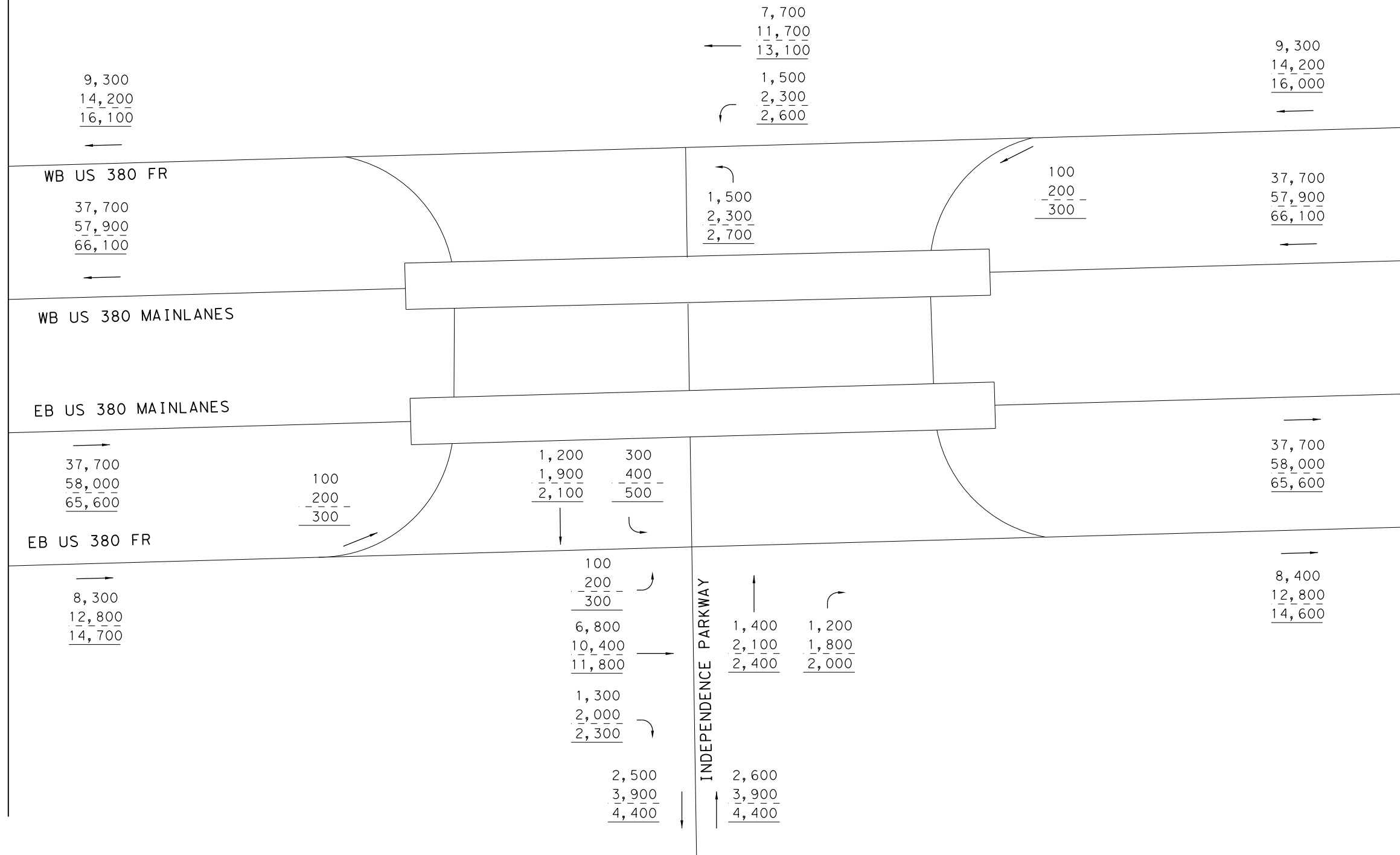
- XXXX- 2030 AVERAGE DAILY TRAFFIC VOLUMES
- XXXX- 2050 AVERAGE DAILY TRAFFIC VOLUMES
- XXXX- 2060 AVERAGE DAILY TRAFFIC VOLUMES

DATE: 7/13/2021
FILE: US380_BLUE_TRF_03.dgn



SEE SHEET 3 OF 63

SEE SHEET 5 OF 63



NOT TO SCALE

NOT INTENDED FOR CONSTRUCTION,
 BIDDING OR PERMIT PURPOSES
 DHRUVA LAHON, P.E.
 SERIAL NUMBER 102185

US 380 BLUE ALT AND
 INDEPENDENCE PKWY
 AVERAGE DAILY TRAFFIC
 BLUE ALT BUILD VOLUMES

Kimley»Horn
F-928

0135-02-065,
 ETC.

SHEET 4 OF 63

LEGEND

- XXXX- 2030 AVERAGE DAILY TRAFFIC VOLUMES
- XXXX- 2050 AVERAGE DAILY TRAFFIC VOLUMES
- XXXX- 2060 AVERAGE DAILY TRAFFIC VOLUMES

DATE: 7/13/2021
 FILE: US380_BLUE_TRF_04.dgn



SEE SHEET 4 OF 63

SEE SHEET 6 OF 63

9,300
14,200
16,000

WB US 380 FR

37,700
57,900
66,100

WB US 380 MAINLANES

EB US 380 MAINLANES

37,700
58,000
65,600

EB US 380 FR

8,400
12,800
14,600

15,200
23,200
26,300

31,800
48,900
55,800

6,400
9,900
12,100

14,800
22,700
26,700

ENTRANCE FROM N CUSTER RD (FM 2478)

5,900
9,000
10,300

EXIT TO N CUSTER RD (FM 2478)

6,400
9,900
12,100

NOT TO SCALE

NOT INTENDED FOR CONSTRUCTION,
BIDDING OR PERMIT PURPOSES
DHURVA LAHON, P.E.
SERIAL NUMBER 102185

US 380 BLUE ALT AND
RAMPS
AVERAGE DAILY TRAFFIC
BLUE ALT BUILD VOLUMES

Kimley»Horn
F-928

0135-02-065,
ETC.

SHEET 5 OF 63

LEGEND

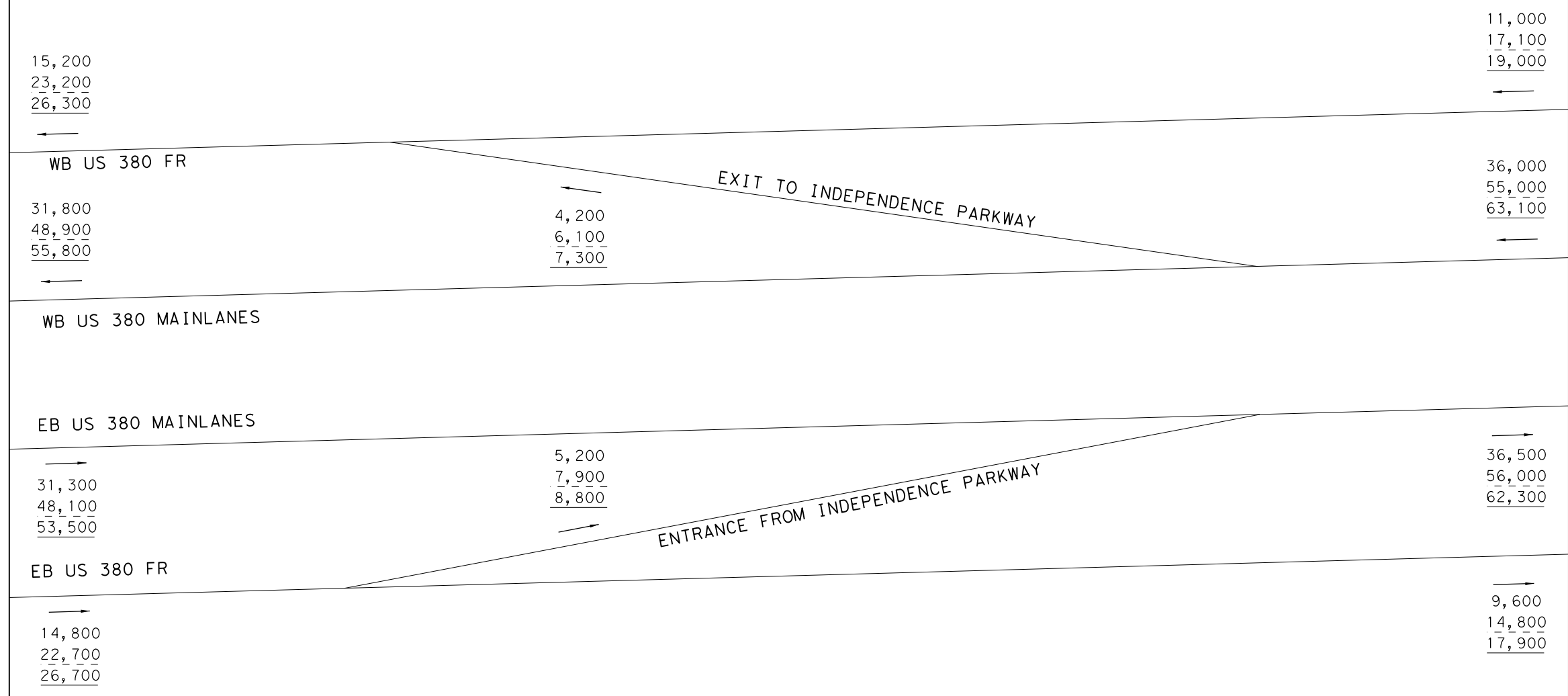
- XXXX- 2030 AVERAGE DAILY TRAFFIC VOLUMES
- XXXX- 2050 AVERAGE DAILY TRAFFIC VOLUMES
- XXXX- 2060 AVERAGE DAILY TRAFFIC VOLUMES

DATE: 7/13/2021
FILE: US380_BLUE_TRF_05.dgn



SEE SHEET 5 OF 63

SEE SHEET 7 OF 63



NOT TO SCALE

NOT INTENDED FOR CONSTRUCTION,
 BIDDING OR PERMIT PURPOSES
 DHRUVA LAHON, P.E.
 SERIAL NUMBER 102185

US 380 BLUE ALT AND
 RAMPS
 AVERAGE DAILY TRAFFIC
 BLUE ALT BUILD VOLUMES



LEGEND

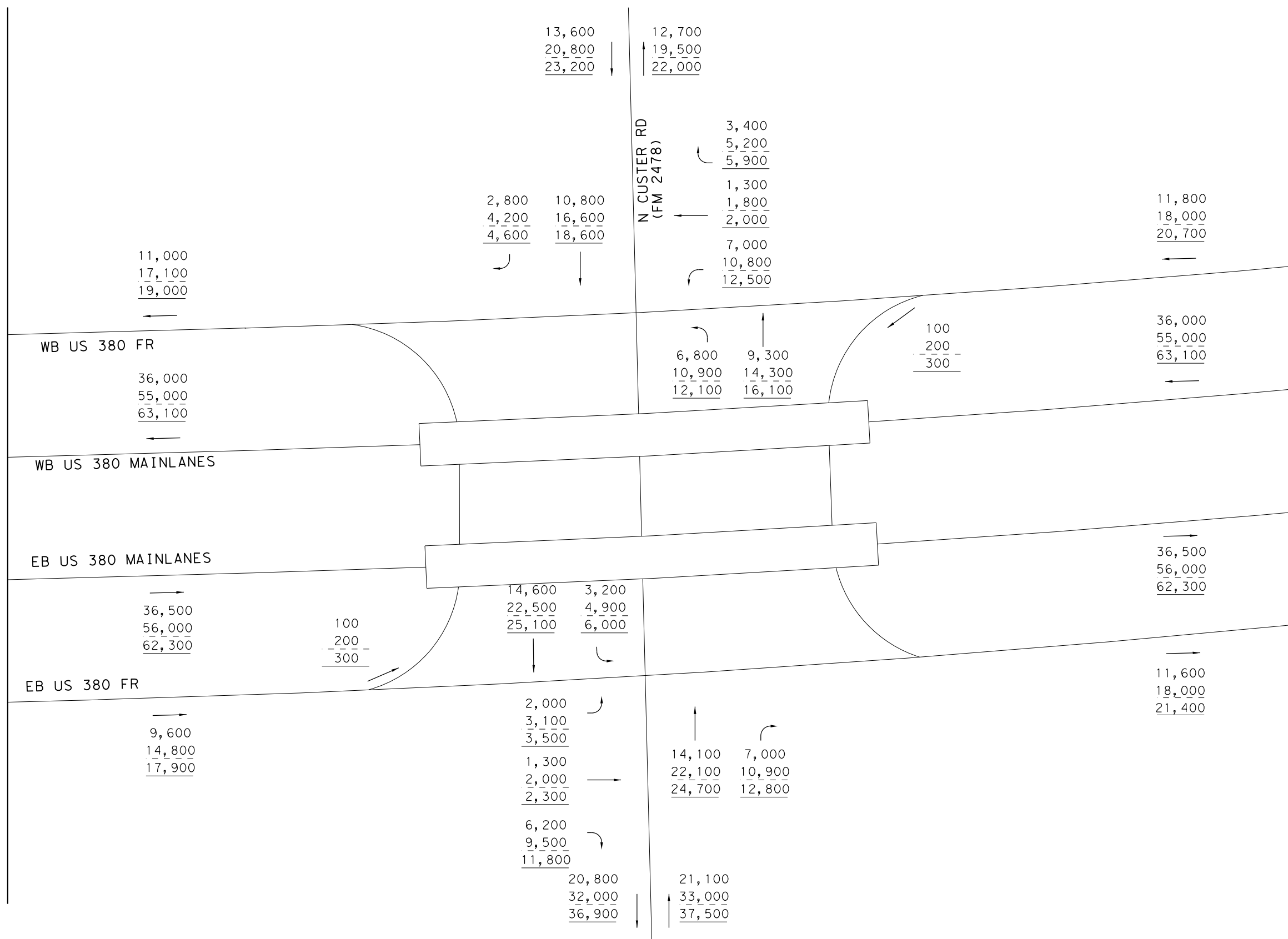
- XXXX- 2030 AVERAGE DAILY TRAFFIC VOLUMES
- XXXX- 2050 AVERAGE DAILY TRAFFIC VOLUMES
- XXXX- 2060 AVERAGE DAILY TRAFFIC VOLUMES

DATE: 7/13/2021
FILE: US380_BLUE_TRF_06.dgn



SEE SHEET 6 OF 63

SEE SHEET 8 OF 63



LEGEND

- XXXX- 2030 AVERAGE DAILY TRAFFIC VOLUMES
- XXX- 2050 AVERAGE DAILY TRAFFIC VOLUMES
- XX- 2060 AVERAGE DAILY TRAFFIC VOLUMES

NOT TO SCALE

NOT INTENDED FOR CONSTRUCTION,
 BIDDING OR PERMIT PURPOSES
 DHRUVA LAHON, P.E.
 SERIAL NUMBER 102185

US 380 BLUE ALT AND
 N CUSTER RD
 AVERAGE DAILY TRAFFIC
 BLUE ALT BUILD VOLUMES

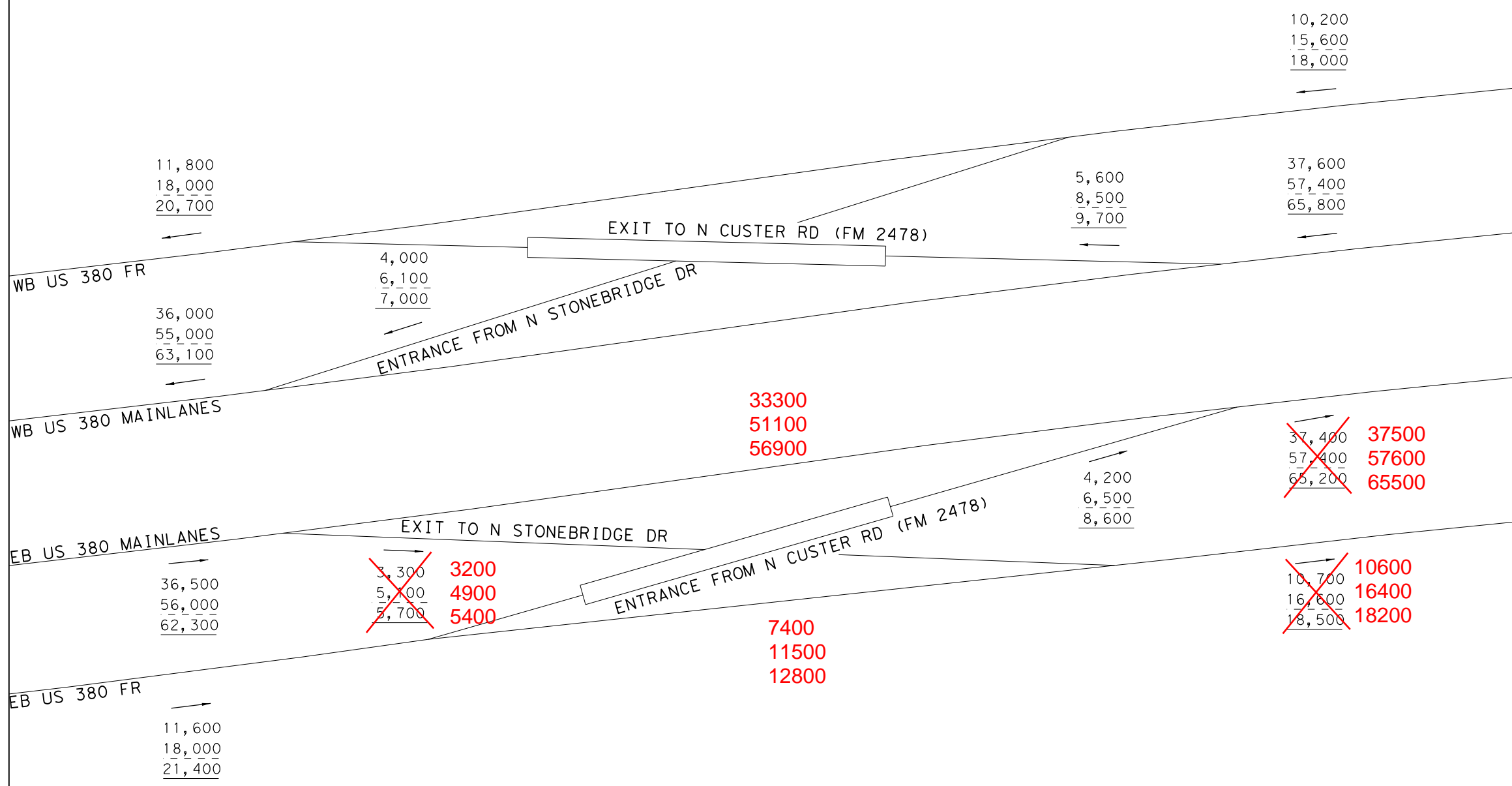


DATE: 7/13/2021
 FILE: US380_BLUE_TRF_07.dgn



SEE SHEET 7 OF 63

SEE SHEET 9 OF 63



NOT TO SCALE

NOT INTENDED FOR CONSTRUCTION,
BIDDING OR PERMIT PURPOSES
DHURVA LAHON, P.E.
SERIAL NUMBER 102185

US 380 BLUE ALT AND
RAMPS
AVERAGE DAILY TRAFFIC
BLUE ALT BUILD VOLUMES

Kimley»Horn
F-928

0135-02-065,
ETC.

SHEET 8 OF 63

LEGEND

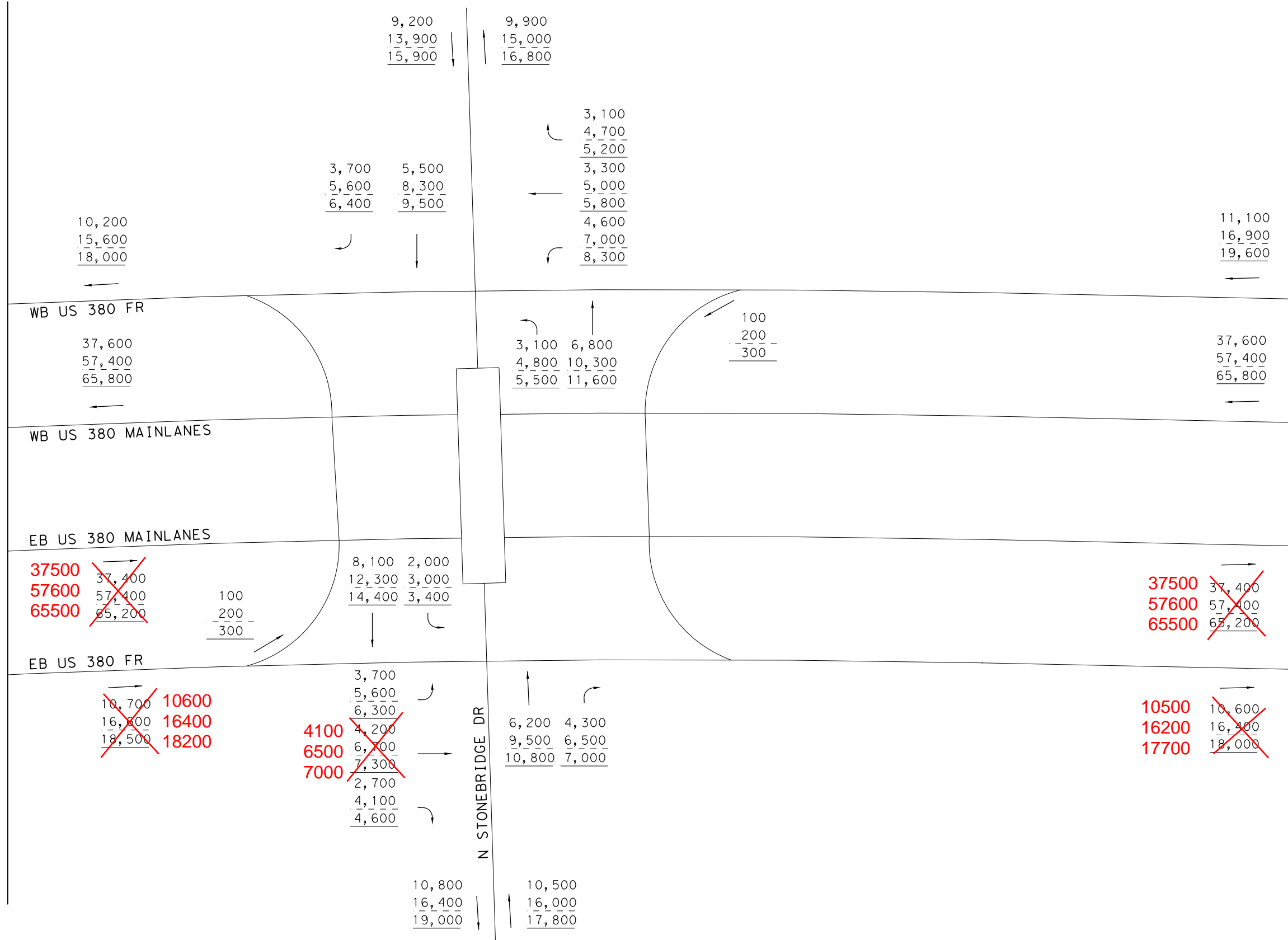
- XXXX- 2030 AVERAGE DAILY TRAFFIC VOLUMES
- XXXX- 2050 AVERAGE DAILY TRAFFIC VOLUMES
- XXXX- 2060 AVERAGE DAILY TRAFFIC VOLUMES

DATE: 7/13/2021
FILE: US380_BLUE_TRF_08.dgn



SEE SHEET 8 OF 63

SEE SHEET 10 OF 63



NOT TO SCALE

NOT INTENDED FOR CONSTRUCTION,
 BIDDING OR PERMIT PURPOSES
 DHRUVA LAHON, P.E.
 SERIAL NUMBER 102185

US 380 BLUE ALT AND
 STONEBRIDGE DR
 AVERAGE DAILY TRAFFIC
 BLUE ALT BUILD VOLUMES

Kimley»Horn
F-928

0135-02-065,
 ETC. SHEET 9 OF 63

LEGEND

- XXXX- 2030 AVERAGE DAILY TRAFFIC VOLUMES
- XXXX- 2050 AVERAGE DAILY TRAFFIC VOLUMES
- XXXX- 2060 AVERAGE DAILY TRAFFIC VOLUMES

DATE: 7/13/2021
 FILE: US380_BLUE_TRF_09.dgn



SEE SHEET 9 OF 63

SEE SHEET 11 OF 63

11,100
16,900
19,600

WB US 380 FR
37,600
57,400
65,800

WB US 380 MAINLANES

EB US 380 MAINLANES

~~37,400~~ 37500
~~57,400~~ 57600
~~65,200~~ 65500

EB US 380 FR

~~10,600~~ 10500
~~16,400~~ 16200
~~18,000~~ 17700

2,500
3,800
4,900

2,400
3,700
4,000

2400
3600
4600

~~2,500~~
~~3,800~~
~~4,900~~

100
200
300

TREMONT BLVD

~~2,400~~
~~3,700~~
~~4,000~~
~~8,600~~
~~13,100~~
~~14,700~~

2300
3500
3700
8100
12400
13900

~~11,000~~
~~16,800~~
~~18,700~~

10500
16100
17900

100
200
300
600 100
900 200
1100 300

200
400
600

700
1100
1400

9800
15100
16300

NOT TO SCALE

NOT INTENDED FOR CONSTRUCTION,
BIDDING OR PERMIT PURPOSES
DHURVA LAHON, P.E.
SERIAL NUMBER 102185

US 380 BLUE ALT AND
TREMONT BLVD
AVERAGE DAILY TRAFFIC
BLUE ALT BUILD VOLUMES

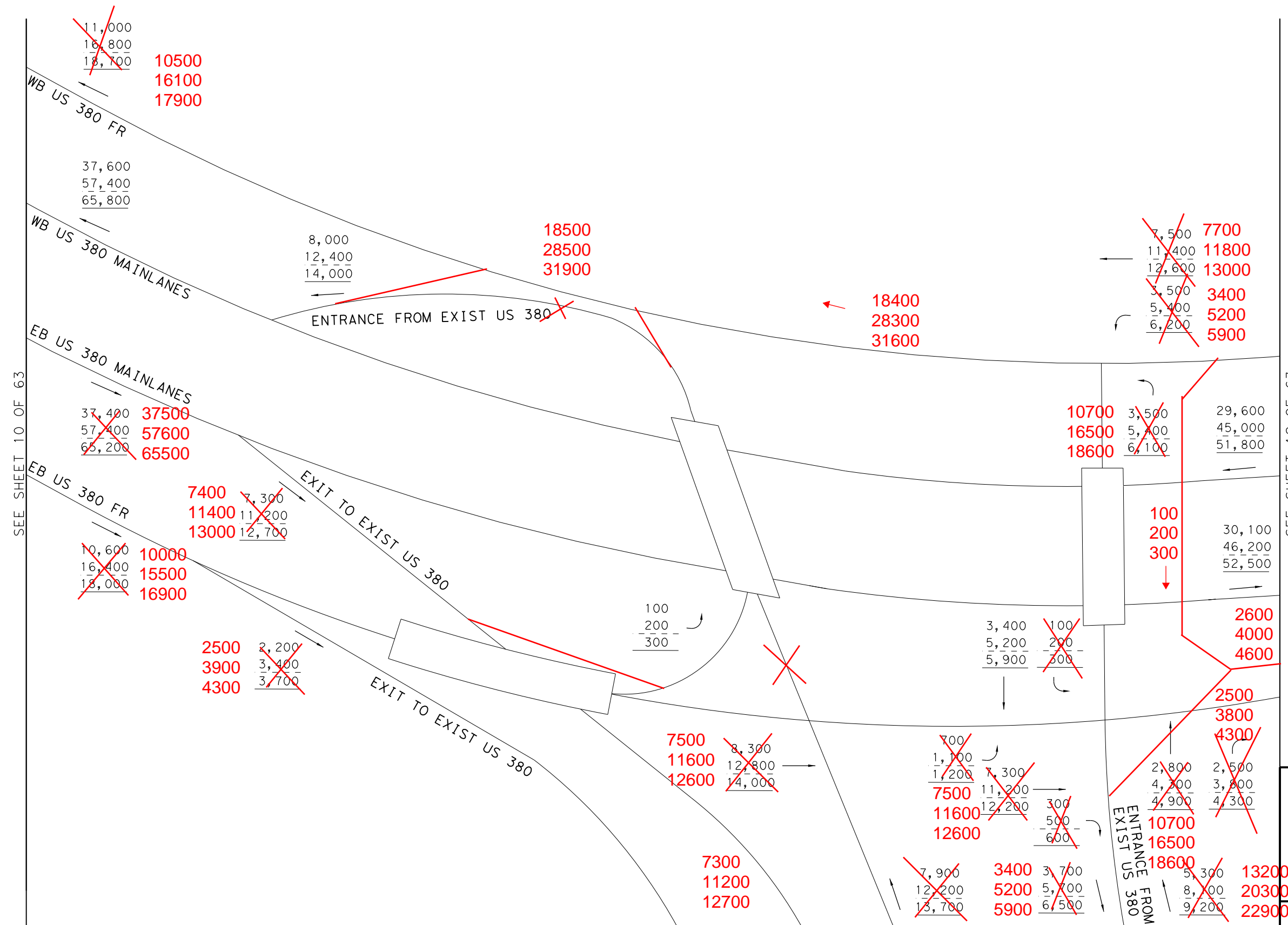
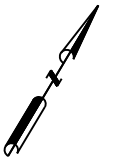
Kimley»Horn
F-928

0135-02-065,
ETC. SHEET 10 OF 63

LEGEND

- XXXX- 2030 AVERAGE DAILY TRAFFIC VOLUMES
- XXXX- 2050 AVERAGE DAILY TRAFFIC VOLUMES
- XXXX- 2060 AVERAGE DAILY TRAFFIC VOLUMES

DATE: 7/13/2021
FILE: US380_BLUE_TRF_10.dgn



SEE SHEET 10 OF 63

SEE SHEET 12 OF 63

SEE SHEET 11A OF 63

NOT TO SCALE

NOT INTENDED FOR CONSTRUCTION,
 BIDDING OR PERMIT PURPOSES
 DHRUVA LAHON, P.E.
 SERIAL NUMBER 102185

US 380 BLUE ALT AND
 RAMPS
 AVERAGE DAILY TRAFFIC
 BLUE ALT BUILD VOLUMES

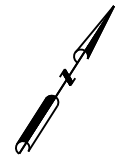
Kimley»Horn
F-928

0135-02-065,
 ETC. SHEET 11 OF 63

LEGEND

- XXXX- 2030 AVERAGE DAILY TRAFFIC VOLUMES
- XXXX- 2050 AVERAGE DAILY TRAFFIC VOLUMES
- XXXX- 2060 AVERAGE DAILY TRAFFIC VOLUMES

DATE: 7/13/2021
 FILE: US380_BLUE_TRF-11.dgn



2500
3900
4300

~~2,200~~
~~3,400~~
~~3,700~~

7,300
11,200
12,700

ENTRANCE FROM
EB US 380 FR

ENTRANCE FROM
EB US 380 MAINLANES

EXIT TO WB US 380
MAINLANES

~~7,900~~
~~12,200~~
~~13,700~~

~~4,700~~
~~5,700~~
~~6,500~~

3400
5200
5900

ENTRANCE FROM
US 380 FR

EXIT TO FR
US 380

~~5,300~~
~~8,100~~
~~9,200~~

13200
20300
22900

~~5,300~~
~~8,100~~
~~9,200~~

13200
20300
22900

~~7,900~~
~~12,200~~
~~13,700~~

13,200
20,300
22,900

WB US 380 EXISTING

EB US 380 EXISTING

13,200
20,300
22,900

SEE SHEET 47 OF 63

NOT TO SCALE

NOT INTENDED FOR CONSTRUCTION,
BIDDING OR PERMIT PURPOSES
DHURVA LAHON, P.E.
SERIAL NUMBER 102185

US 380 BLUE ALT AND
EXISTING US 380
AVERAGE DAILY TRAFFIC
BLUE ALT BUILD VOLUMES

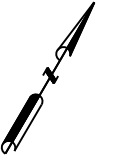
Kimley»Horn
F-928

0135-02-065,
ETC. SHEET 11A OF 63

LEGEND

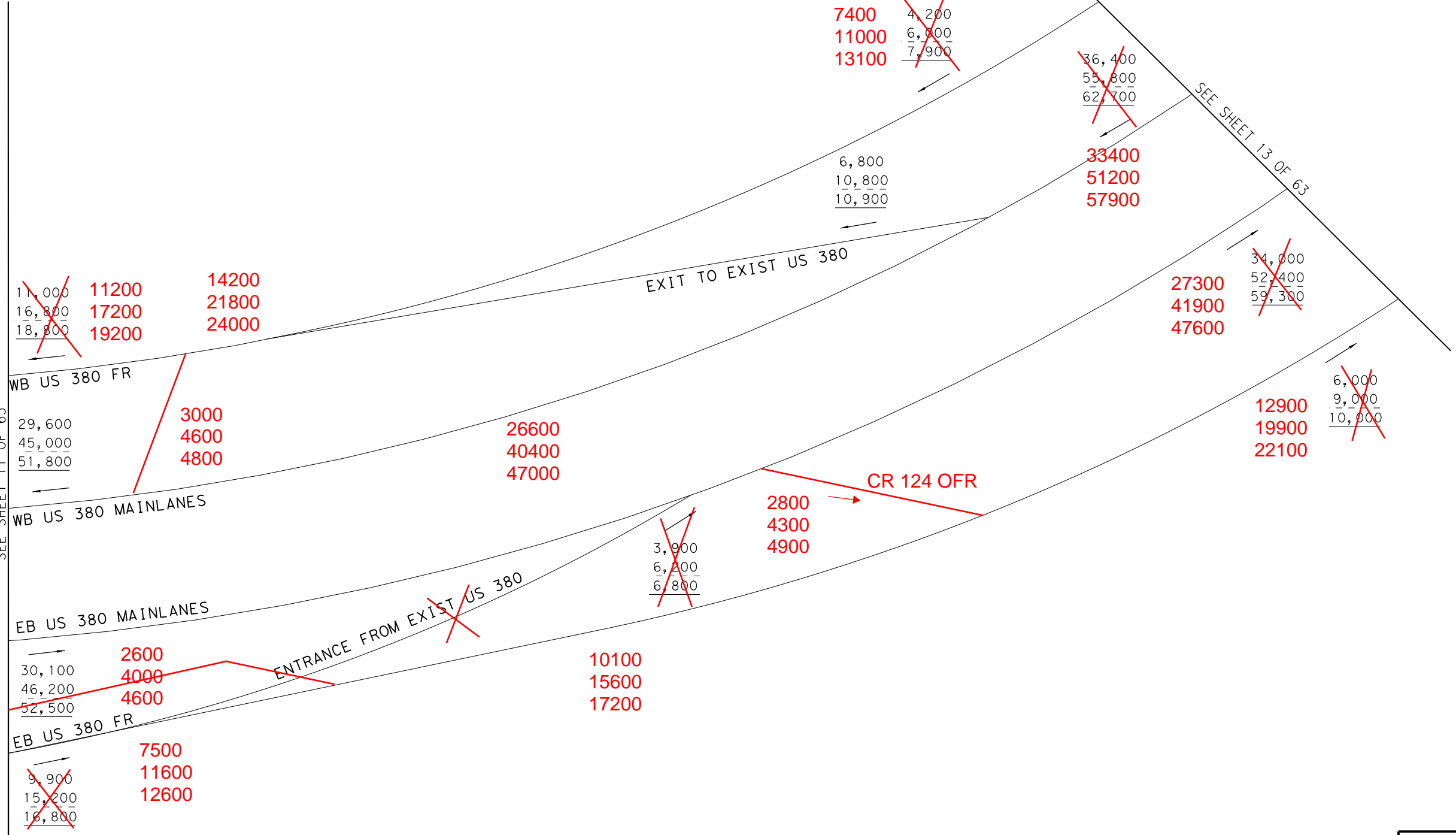
- XXXX- 2030 AVERAGE DAILY TRAFFIC VOLUMES
- XXXX- 2050 AVERAGE DAILY TRAFFIC VOLUMES
- XXXX- 2060 AVERAGE DAILY TRAFFIC VOLUMES

DATE: 7/13/2021
FILE: US380_BLUE_TRF_11a.dgn



SEE SHEET 11 OF 63

SEE SHEET 13 OF 63



LEGEND

- XXXX- 2030 AVERAGE DAILY TRAFFIC VOLUMES
- XXXX- 2050 AVERAGE DAILY TRAFFIC VOLUMES
- XXXX- 2060 AVERAGE DAILY TRAFFIC VOLUMES

NOT TO SCALE

NOT INTENDED FOR CONSTRUCTION,
 BIDDING OR PERMIT PURPOSES
 DHRUVA LAHON, P.E.
 SERIAL NUMBER 102185

US 380 BLUE ALT AND
 RAMPS
 AVERAGE DAILY TRAFFIC
 BLUE ALT BUILD VOLUMES





SEE SHEET 12 OF 63

SEE SHEET 14 OF 63

4,200	7400
6,000	11000
7,900	13100

7,200	7400
10,600	11000
12,700	13100

WB US 380 FR

36,400	33400
55,800	51200
62,700	57900

3,000
4,800
4,800

ENTRANCE FROM CR 124

33,400
51,200
57,900

WB US 380 MAINLANES

EB US 380 MAINLANES

27300	34,000	3900
41900	52,400	6200
47600	59,300	6800

Exist US 380 ONR

2,800
4,800
4,900

EXIT TO CR 124

31,200
48,100
54,400

EB US 380 FR

12900	6,000
19900	9,000
22100	10,000

9000	8,800
13700	13,800
15300	14,900

NOT TO SCALE

NOT INTENDED FOR CONSTRUCTION,
BIDDING OR PERMIT PURPOSES
DHURVA LAHON, P.E.
SERIAL NUMBER 102185

US 380 BLUE ALT AND
RAMPS
AVERAGE DAILY TRAFFIC
BLUE ALT BUILD VOLUMES



0135-02-065,
ETC. SHEET 13 OF 63

LEGEND

- XXXX- 2030 AVERAGE DAILY TRAFFIC VOLUMES
- XXXX- 2050 AVERAGE DAILY TRAFFIC VOLUMES
- XXXX- 2060 AVERAGE DAILY TRAFFIC VOLUMES

DATE: 7/13/2021
FILE: US380_BLUE_TRF_13.dgn



~~7,200~~ **7400**
~~10,600~~ **11000**
~~12,700~~ **13100**

5,200 5,700
7,900 8,400
9,200 9,100

1,200 4,000
1,800 6,100
2,200 7,000

2,100
3,200
3,500
3,700
5,500
6,500
2,100
3,200
3,500

8,000
12,100
13,800

WB US 380 FR

33,400
51,200
57,900

2,200 3,600
3,100 5,200
3,700 5,600

100
200
300

33,400
51,200
57,900

WB US 380 MAINLANES

EB US 380 MAINLANES

31,200
48,100
54,400

300
600
700

~~100~~
~~200~~
~~300~~

3,800 2,300
5,800 3,500
6,400 4,100

31,200
48,100
54,400

EB US 380 FR

~~8,800~~ **9000**
~~13,300~~ **13700**
~~14,900~~ **15300**

1,200
1,700
1,900
5,500
8,300
9,200
2,000
3,100
3,500

4,600 2,600
6,600 4,100
7,400 4,600

10,500
16,100
18,200

CR 124

5,800 7,200
8,900 10,700
9,900 12,000

SEE SHEET 13 OF 63

SEE SHEET 15 OF 63

NOT TO SCALE

NOT INTENDED FOR CONSTRUCTION,
BIDDING OR PERMIT PURPOSES
DHRUVA LAHON, P.E.
SERIAL NUMBER 102185

US 380 BLUE ALT AND
CR 124
AVERAGE DAILY TRAFFIC
BLUE ALT BUILD VOLUMES

Kimley»Horn
F-928

0135-02-065,
ETC. SHEET 14 OF 63

LEGEND

- XXXX- 2030 AVERAGE DAILY TRAFFIC VOLUMES
- XXXX- 2050 AVERAGE DAILY TRAFFIC VOLUMES
- XXXX- 2060 AVERAGE DAILY TRAFFIC VOLUMES

DATE: 7/13/2021
FILE: US380_BLUE_TRF_14.dgn



SEE SHEET 14 OF 63

SEE SHEET 16 OF 63

8,000
12,100
13,800

12,600
19,200
21,800

WB US 380 FR

4,600
7,100
8,000

ENTRANCE FROM BLOOMDALE RD WEST

28,800
44,100
49,900

WB US 380 MAINLANES

EB US 380 MAINLANES

31,200
48,100
54,400

2,500
3,900
4,400

EXIT TO BLOOMDALE RD WEST

28,700
44,200
50,000

EB US 380 FR

10,500
16,100
18,200

13,000
20,000
22,600

NOT TO SCALE

NOT INTENDED FOR CONSTRUCTION,
BIDDING OR PERMIT PURPOSES
DHURVA LAHON, P.E.
SERIAL NUMBER 102185

US 380 BLUE ALT AND
RAMPS
AVERAGE DAILY TRAFFIC
BLUE ALT BUILD VOLUMES



0135-02-065,
ETC. SHEET 15 OF 63

LEGEND

- XXXX- 2030 AVERAGE DAILY TRAFFIC VOLUMES
- XXXX- 2050 AVERAGE DAILY TRAFFIC VOLUMES
- XXXX- 2060 AVERAGE DAILY TRAFFIC VOLUMES

DATE: 7/13/2021
FILE: US380_BLUE_TRF_15.dgn



SEE SHEET 15 OF 63

SEE SHEET 17 OF 63

12,600
19,200
21,800

WB US 380 FR

28,800
44,100
49,900

WB US 380 MAINLANES

EB US 380 MAINLANES

28,700
44,200
50,000

EB US 380 FR

13,000
20,000
22,600

5,700
8,800
9,900

EXIT TO CR 124

6,500
10,000
11,300

ENTRANCE FROM CR 124

6,900
10,400
11,900

34,500
52,900
59,800

35,200
54,200
61,300

6,500
10,000
11,300

NOT TO SCALE

NOT INTENDED FOR CONSTRUCTION,
BIDDING OR PERMIT PURPOSES
DHURVA LAHON, P.E.
SERIAL NUMBER 102185

US 380 BLUE ALT AND
RAMPS
AVERAGE DAILY TRAFFIC
BLUE ALT BUILD VOLUMES

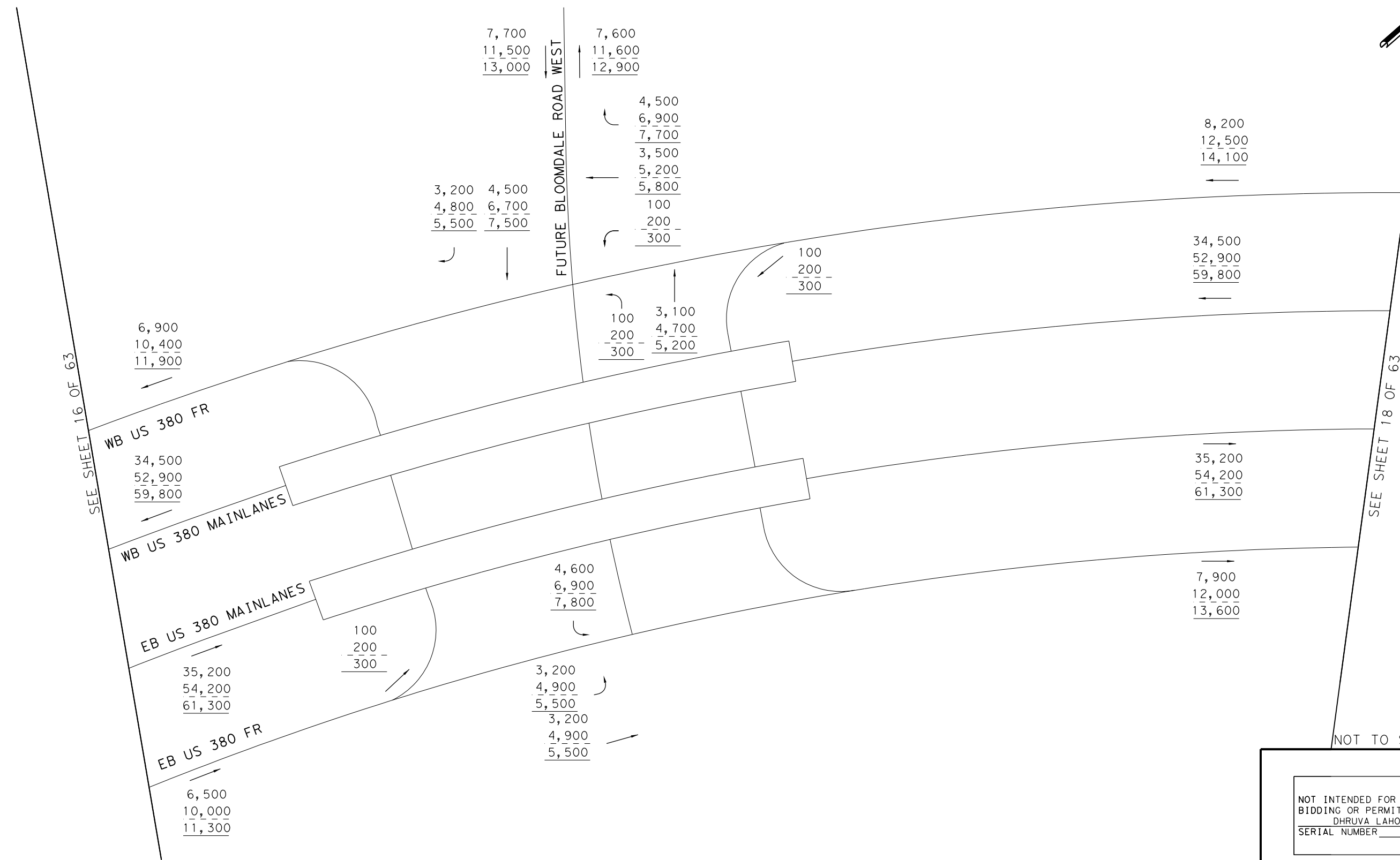
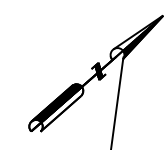
Kimley»Horn
F-928

0135-02-065,
ETC. SHEET 16 OF 63

LEGEND

- XXXX- 2030 AVERAGE DAILY TRAFFIC VOLUMES
- XXXX- 2050 AVERAGE DAILY TRAFFIC VOLUMES
- XXXX- 2060 AVERAGE DAILY TRAFFIC VOLUMES

DATE: 7/13/2021
FILE: US380_BLUE_TRF_16.dgn



SEE SHEET 16 OF 63

SEE SHEET 18 OF 63

NOT TO SCALE

NOT INTENDED FOR CONSTRUCTION,
 BIDDING OR PERMIT PURPOSES
 DHRUVA LAHON, P.E.
 SERIAL NUMBER 102185

US3880 BLUE ALT AND
 W BLOOMDALE RD
 AVERAGE DAILY TRAFFIC
 BLUE ALT BUILD VOLUMES



0135-02-065,
 ETC. SHEET 17 OF 63

LEGEND

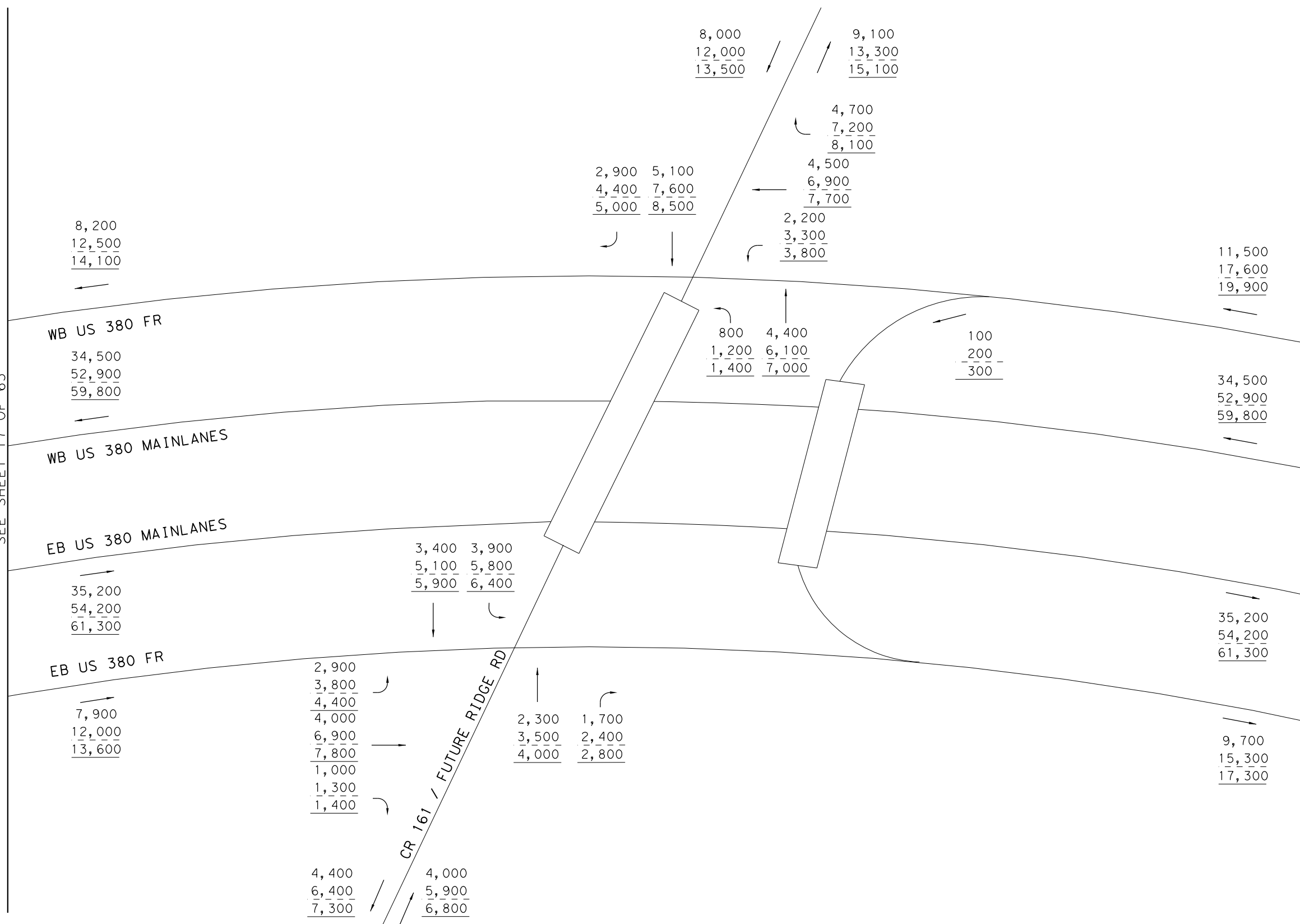
- XXXX- 2030 AVERAGE DAILY TRAFFIC VOLUMES
- XXXX- 2050 AVERAGE DAILY TRAFFIC VOLUMES
- XXXX- 2060 AVERAGE DAILY TRAFFIC VOLUMES

DATE: 7/13/2021
 FILE: US380_BLUE_TRF_17.dgn



SEE SHEET 17 OF 63

SEE SHEET 19 OF 63



LEGEND

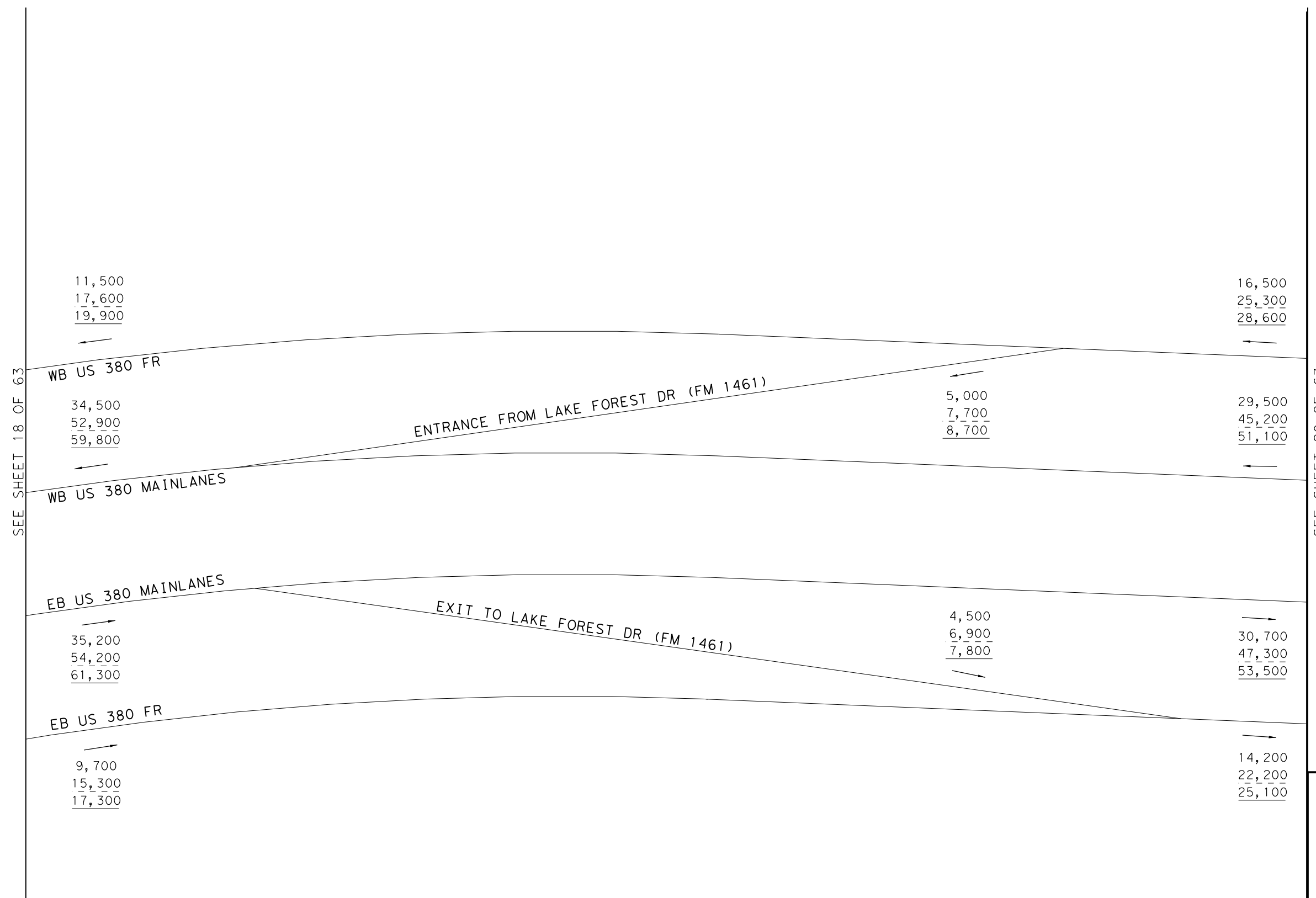
- XXXX- 2030 AVERAGE DAILY TRAFFIC VOLUMES
- XXXX- 2050 AVERAGE DAILY TRAFFIC VOLUMES
- XXXX- 2060 AVERAGE DAILY TRAFFIC VOLUMES

NOT TO SCALE

NOT INTENDED FOR CONSTRUCTION,
 BIDDING OR PERMIT PURPOSES
 DHRUVA LAHON, P.E.
 SERIAL NUMBER 102185

US 380 BLUE ALT AND
 CR 161/FUTURE RIDGE RD
 AVERAGE DAILY TRAFFIC
 BLUE ALT BUILD VOLUMES





SEE SHEET 18 OF 63

SEE SHEET 20 OF 63

NOT TO SCALE

NOT INTENDED FOR CONSTRUCTION,
 BIDDING OR PERMIT PURPOSES
 DHRUVA LAHON, P.E.
 SERIAL NUMBER 102185

US 380 BLUE ALT AND
 RAMPS
 AVERAGE DAILY TRAFFIC
 BLUE ALT BUILD VOLUMES



0135-02-065,
 ETC. SHEET 19 OF 63

LEGEND

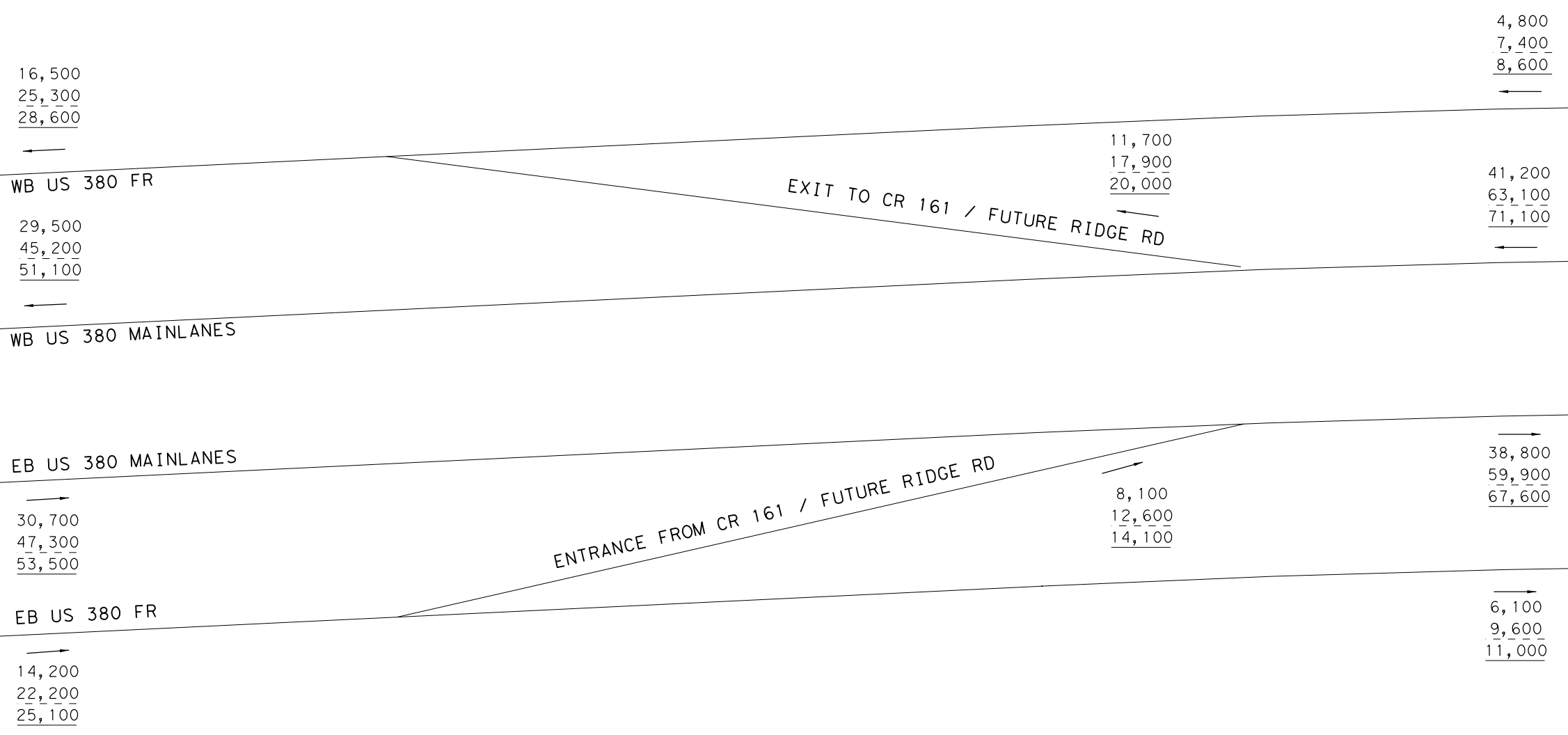
- XXXX- 2030 AVERAGE DAILY TRAFFIC VOLUMES
- XXXX- 2050 AVERAGE DAILY TRAFFIC VOLUMES
- XXXX- 2060 AVERAGE DAILY TRAFFIC VOLUMES

DATE: 7/13/2021
 FILE: US380_BLUE_TRF_19.dgn



SEE SHEET 19 OF 63

SEE SHEET 21 OF 63



LEGEND

- XXXX- 2030 AVERAGE DAILY TRAFFIC VOLUMES
- XXXX- 2050 AVERAGE DAILY TRAFFIC VOLUMES
- XXXX- 2060 AVERAGE DAILY TRAFFIC VOLUMES

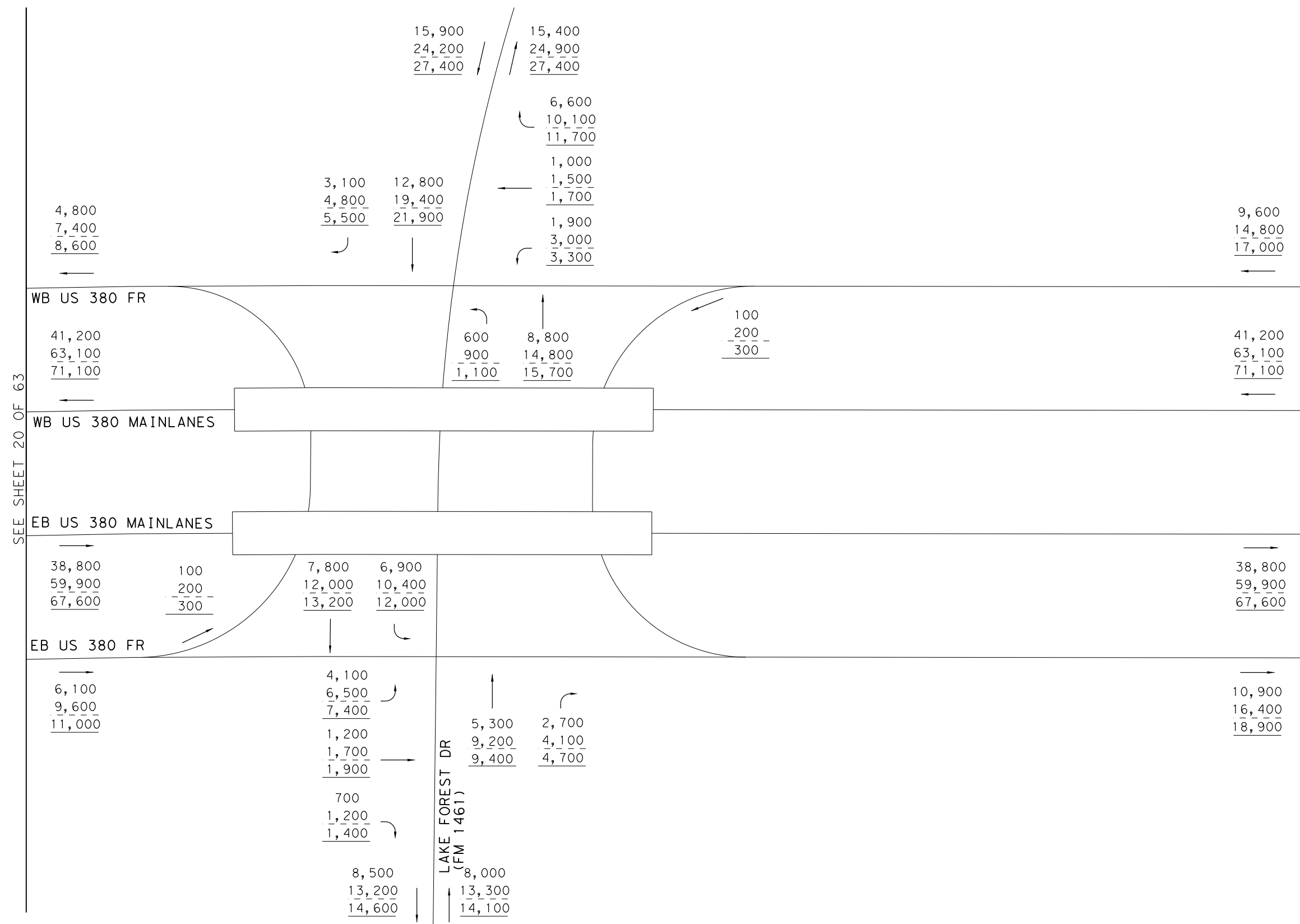
NOT TO SCALE

NOT INTENDED FOR CONSTRUCTION,
 BIDDING OR PERMIT PURPOSES
 DHRUVA LAHON, P.E.
 SERIAL NUMBER 102185

US 380 BLUE ALT AND
 RAMPS
 AVERAGE DAILY TRAFFIC
 BLUE ALT BUILD VOLUMES



DATE: 7/13/2021
 FILE: US380_BLUE_TRF_20.dgn



SEE SHEET 20 OF 63

SEE SHEET 22 OF 63

NOT TO SCALE

NOT INTENDED FOR CONSTRUCTION,
 BIDDING OR PERMIT PURPOSES
 DHRUVA LAHON, P.E.
 SERIAL NUMBER 102185

US 380 BLUE ALT AND
 LAKE FOREST DR
 AVERAGE DAILY TRAFFIC
 BLUE ALT BUILD VOLUMES



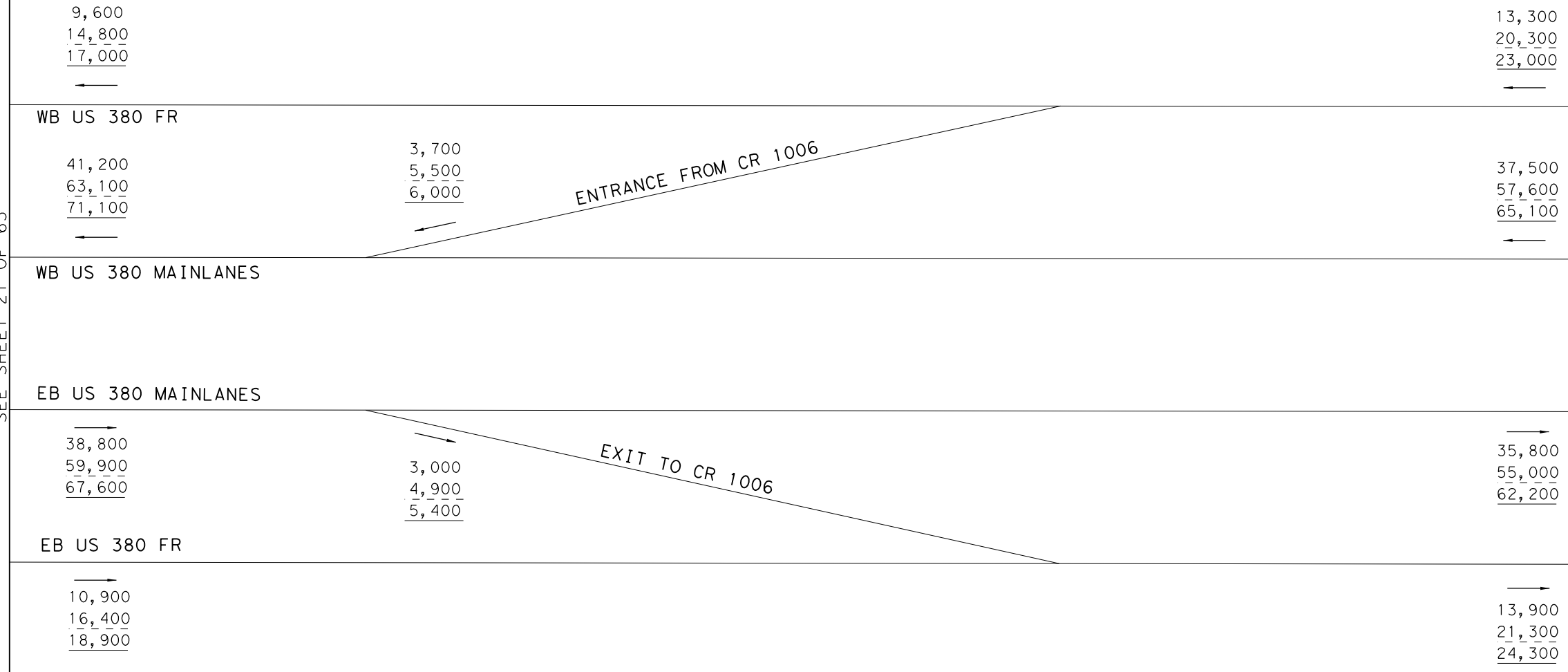
LEGEND

- XXXX- 2030 AVERAGE DAILY TRAFFIC VOLUMES
- XXXX- 2050 AVERAGE DAILY TRAFFIC VOLUMES
- XXXX- 2060 AVERAGE DAILY TRAFFIC VOLUMES



SEE SHEET 21 OF 63

SEE SHEET 23 OF 63



NOT TO SCALE

NOT INTENDED FOR CONSTRUCTION,
 BIDDING OR PERMIT PURPOSES
 DHRUVA LAHON, P.E.
 SERIAL NUMBER 102185

US 380 BLUE ALT AND
 RAMPS
 AVERAGE DAILY TRAFFIC
 BLUE ALT BUILD VOLUMES



0135-02-065,
 ETC. SHEET 22 OF 63

LEGEND

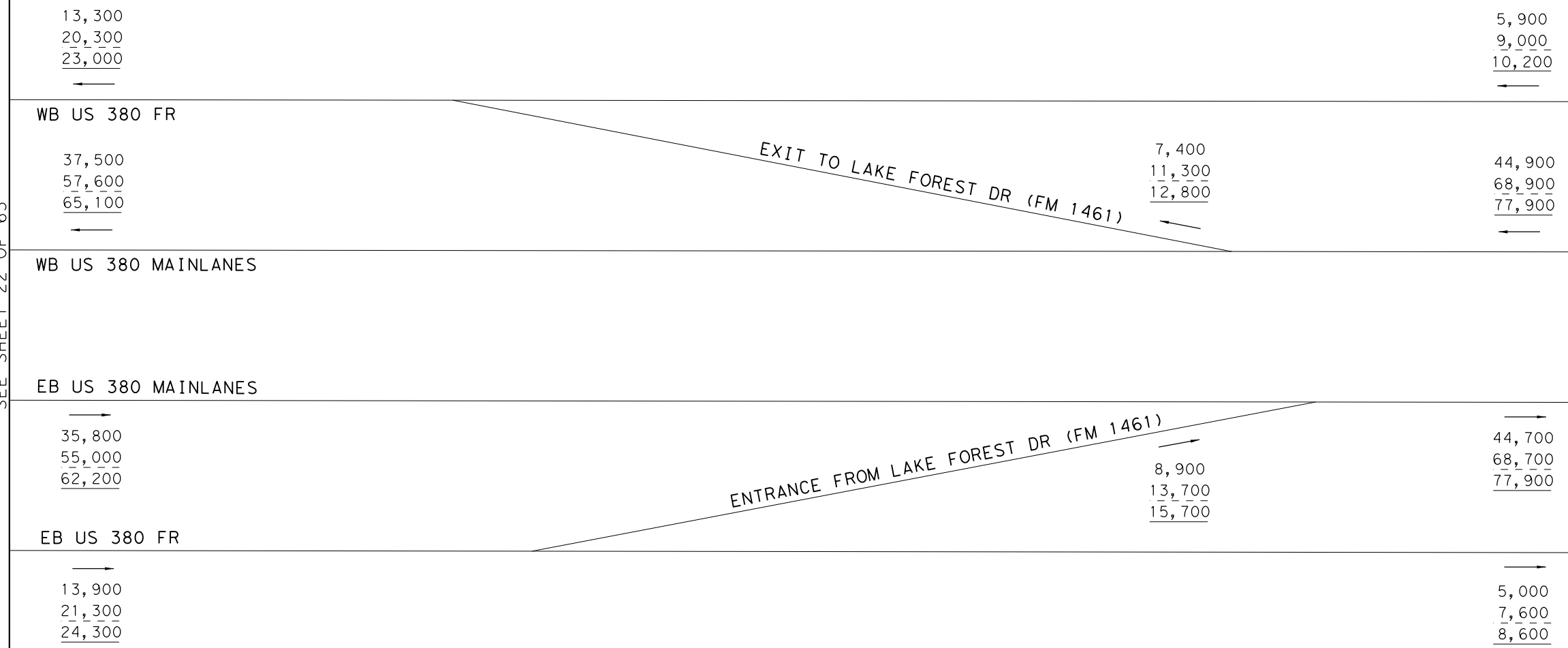
- XXXX- 2030 AVERAGE DAILY TRAFFIC VOLUMES
- XXXX- 2050 AVERAGE DAILY TRAFFIC VOLUMES
- XXXX- 2060 AVERAGE DAILY TRAFFIC VOLUMES

DATE: 7/13/2021
FILE: US380_BLUE_TRF_22.dgn



SEE SHEET 22 OF 63

SEE SHEET 24 OF 63



NOT TO SCALE

NOT INTENDED FOR CONSTRUCTION,
 BIDDING OR PERMIT PURPOSES
 DHRUVA LAHON, P.E.
 SERIAL NUMBER 102185

US 380 BLUE ALT AND
 RAMPS
 AVERAGE DAILY TRAFFIC
 BLUE ALT BUILD VOLUMES



0135-02-065,
 ETC. SHEET 23 OF 63

LEGEND

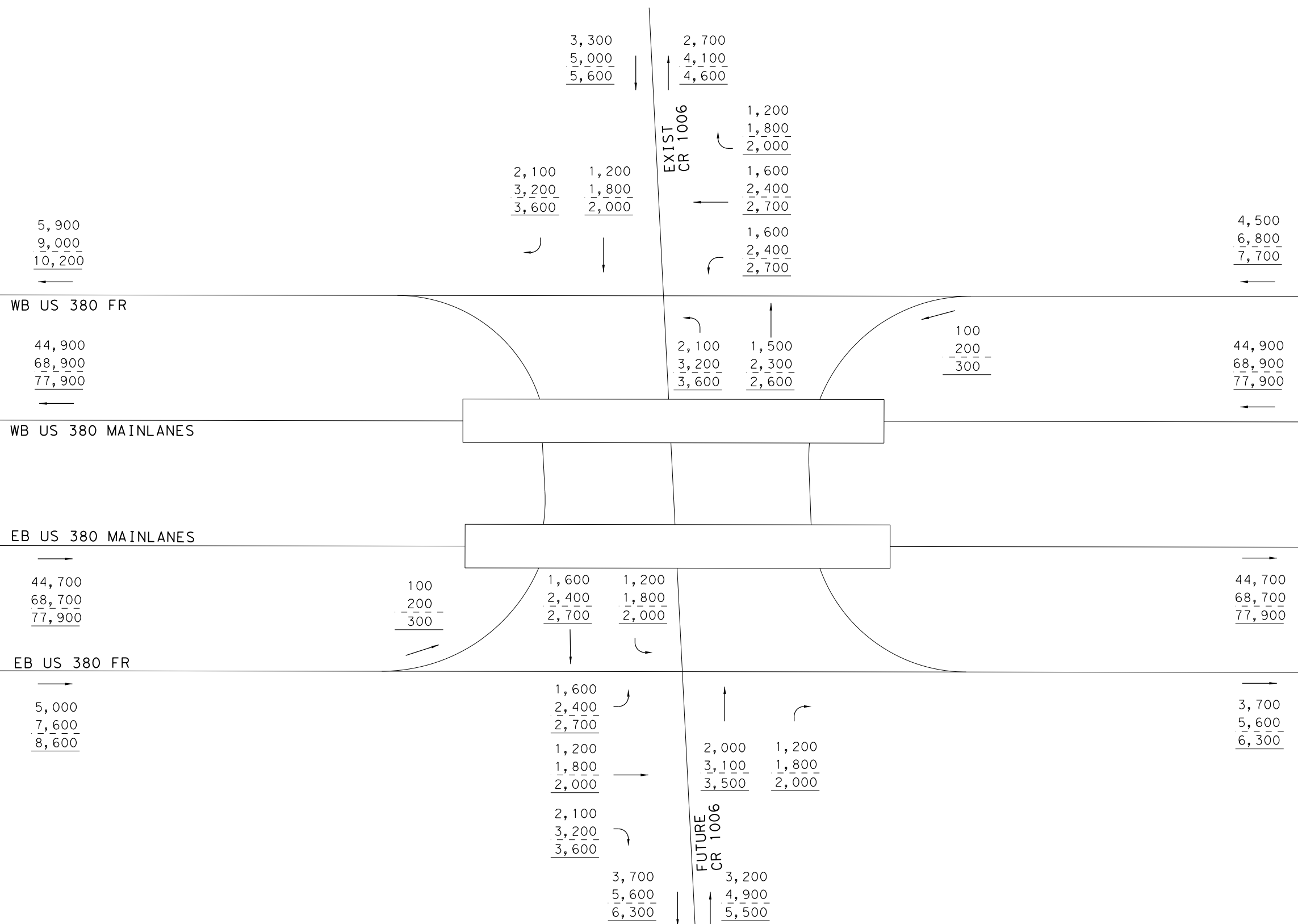
- XXXX- 2030 AVERAGE DAILY TRAFFIC VOLUMES
- XXXX- 2050 AVERAGE DAILY TRAFFIC VOLUMES
- XXXX- 2060 AVERAGE DAILY TRAFFIC VOLUMES

DATE: 7/13/2021
 FILE: US380_BLUE_TRF_23.dgn



SEE SHEET 23 OF 63

SEE SHEET 25 OF 63



LEGEND

- XXXX- 2030 AVERAGE DAILY TRAFFIC VOLUMES
- XXXX- 2050 AVERAGE DAILY TRAFFIC VOLUMES
- XXXX- 2060 AVERAGE DAILY TRAFFIC VOLUMES

NOT TO SCALE

NOT INTENDED FOR CONSTRUCTION,
 BIDDING OR PERMIT PURPOSES
 DHRUVA LAHON, P.E.
 SERIAL NUMBER 102185

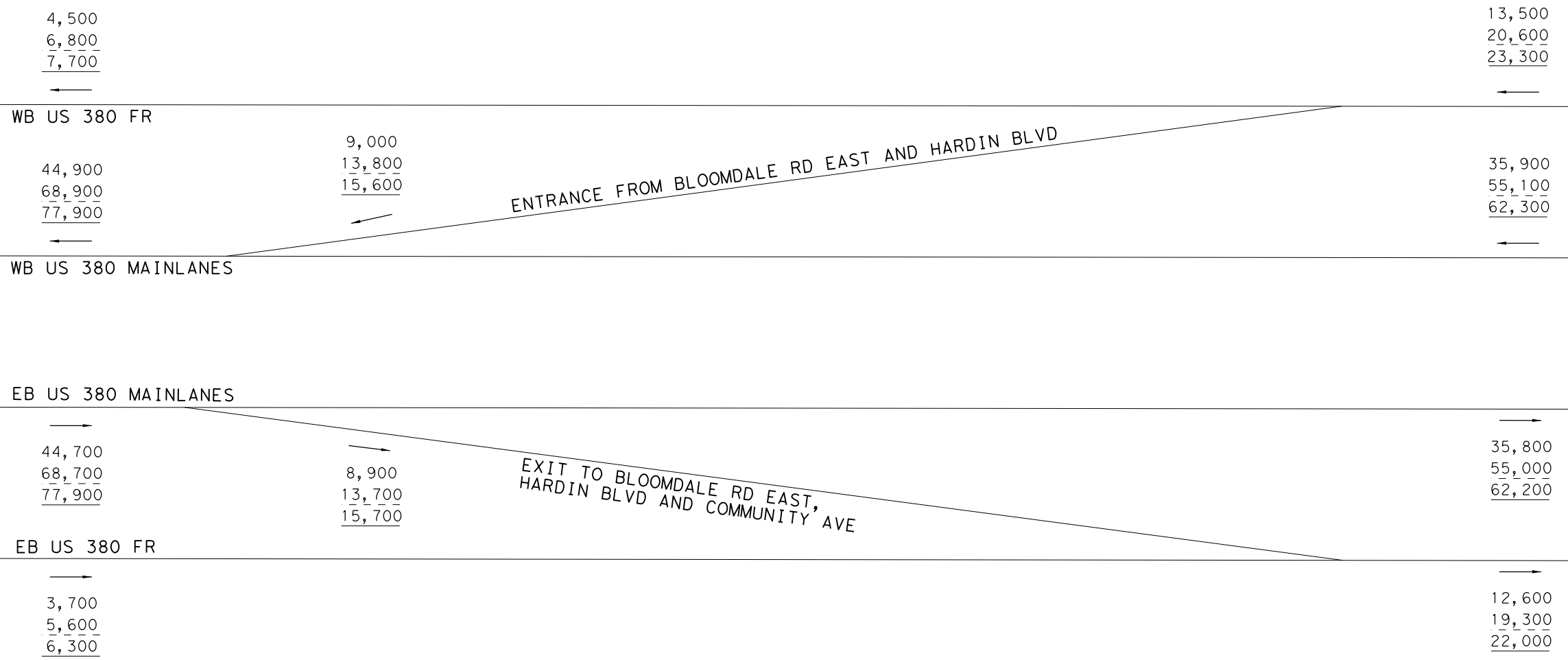
US 380 BLUE ALT AND
 CR 1006
 AVERAGE DAILY TRAFFIC
 BLUE ALT BUILD VOLUMES





SEE SHEET 24 OF 63

SEE SHEET 26 OF 63



NOT TO SCALE

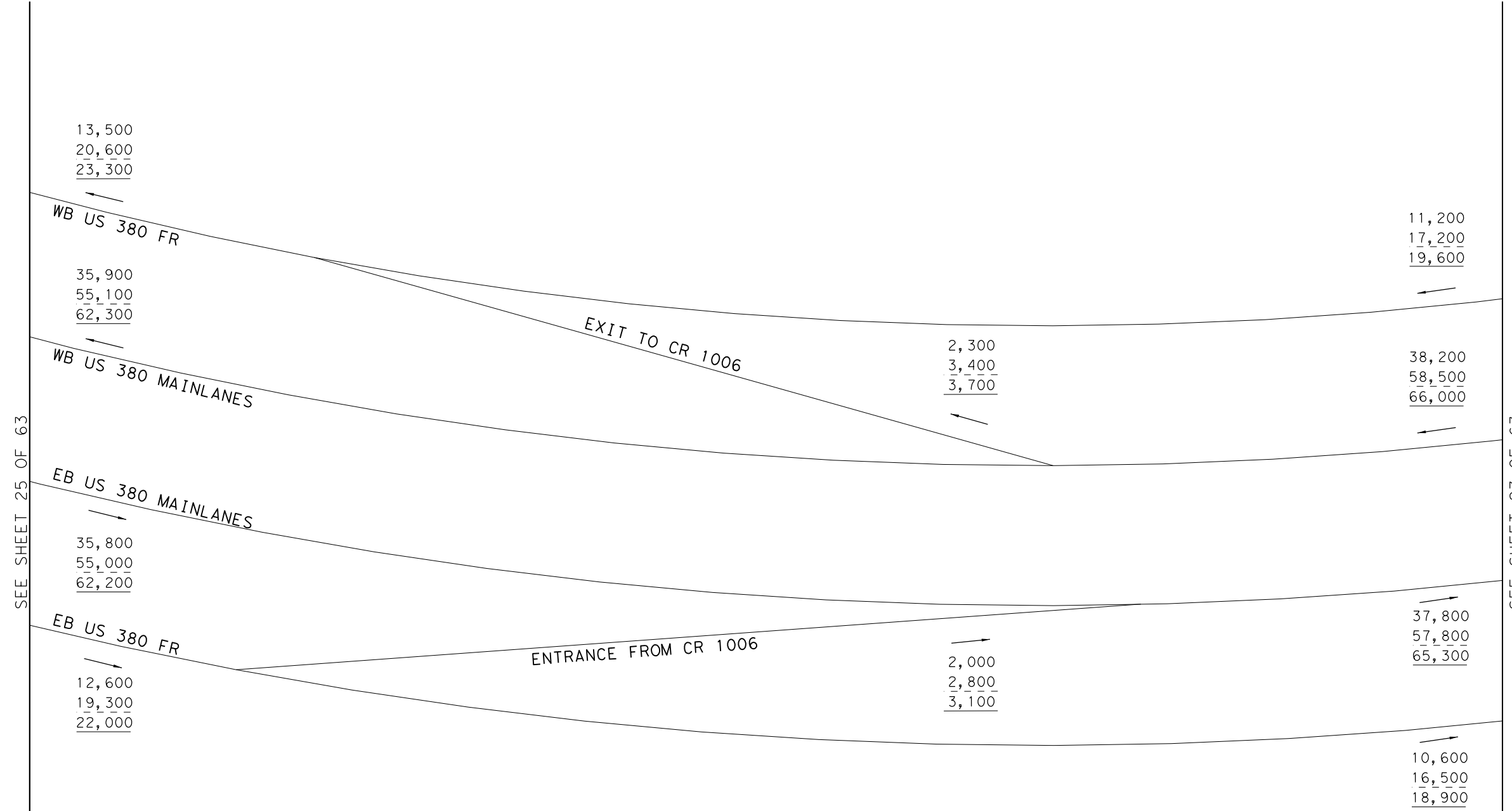
NOT INTENDED FOR CONSTRUCTION,
 BIDDING OR PERMIT PURPOSES
 DHRUVA LAHON, P.E.
 SERIAL NUMBER 102185

US 380 BLUE ALT AND
 RAMPS
 AVERAGE DAILY TRAFFIC
 BLUE ALT BUILD VOLUMES



LEGEND

- XXXX- 2030 AVERAGE DAILY TRAFFIC VOLUMES
- XXXX- 2050 AVERAGE DAILY TRAFFIC VOLUMES
- XXXX- 2060 AVERAGE DAILY TRAFFIC VOLUMES



SEE SHEET 25 OF 63

SEE SHEET 27 OF 63

NOT TO SCALE

NOT INTENDED FOR CONSTRUCTION,
 BIDDING OR PERMIT PURPOSES
 DHRUVA LAHON, P.E.
 SERIAL NUMBER 102185

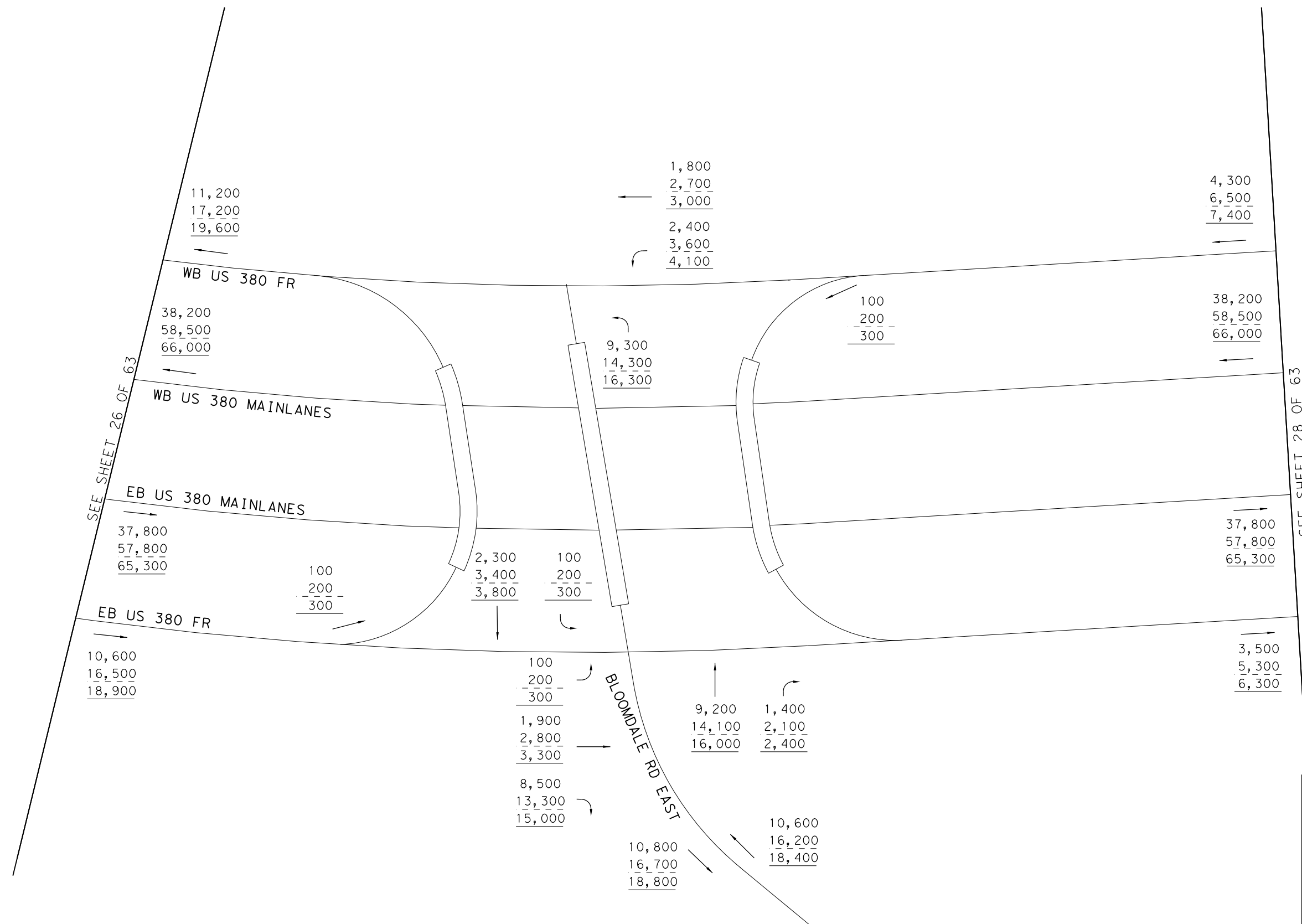
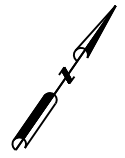
US 380 BLUE ALT AND
 RAMP
 AVERAGE DAILY TRAFFIC
 BLUE ALT BUILD VOLUMES



0135-02-065,
 ETC. SHEET 26 OF 63

LEGEND

- XXXX- 2030 AVERAGE DAILY TRAFFIC VOLUMES
- XXXX- 2050 AVERAGE DAILY TRAFFIC VOLUMES
- XXXX- 2060 AVERAGE DAILY TRAFFIC VOLUMES



SEE SHEET 26 OF 63

SEE SHEET 28 OF 63

NOT TO SCALE

NOT INTENDED FOR CONSTRUCTION,
 BIDDING OR PERMIT PURPOSES
 DHRUVA LAHON, P.E.
 SERIAL NUMBER 102185

US 380 BLUE ALT AND
 E BLOOMDALE RD
 AVERAGE DAILY TRAFFIC
 BLUE ALT BUILD VOLUMES

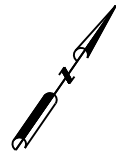


0135-02-065,
 ETC. SHEET 27 OF 63

LEGEND

- XXXX- 2030 AVERAGE DAILY TRAFFIC VOLUMES
- XXXX- 2050 AVERAGE DAILY TRAFFIC VOLUMES
- XXXX- 2060 AVERAGE DAILY TRAFFIC VOLUMES

DATE: 7/13/2021
 FILE: US380_BLUE_TRF_27.dgn



SEE SHEET 27 OF 63

SEE SHEET 29 OF 63

NOT TO SCALE

NOT INTENDED FOR CONSTRUCTION,
 BIDDING OR PERMIT PURPOSES
 DHRUVA LAHON, P.E.
 SERIAL NUMBER 102185

US 380 BLUE ALT

AVERAGE DAILY TRAFFIC
BLUE ALT BUILD VOLUMES

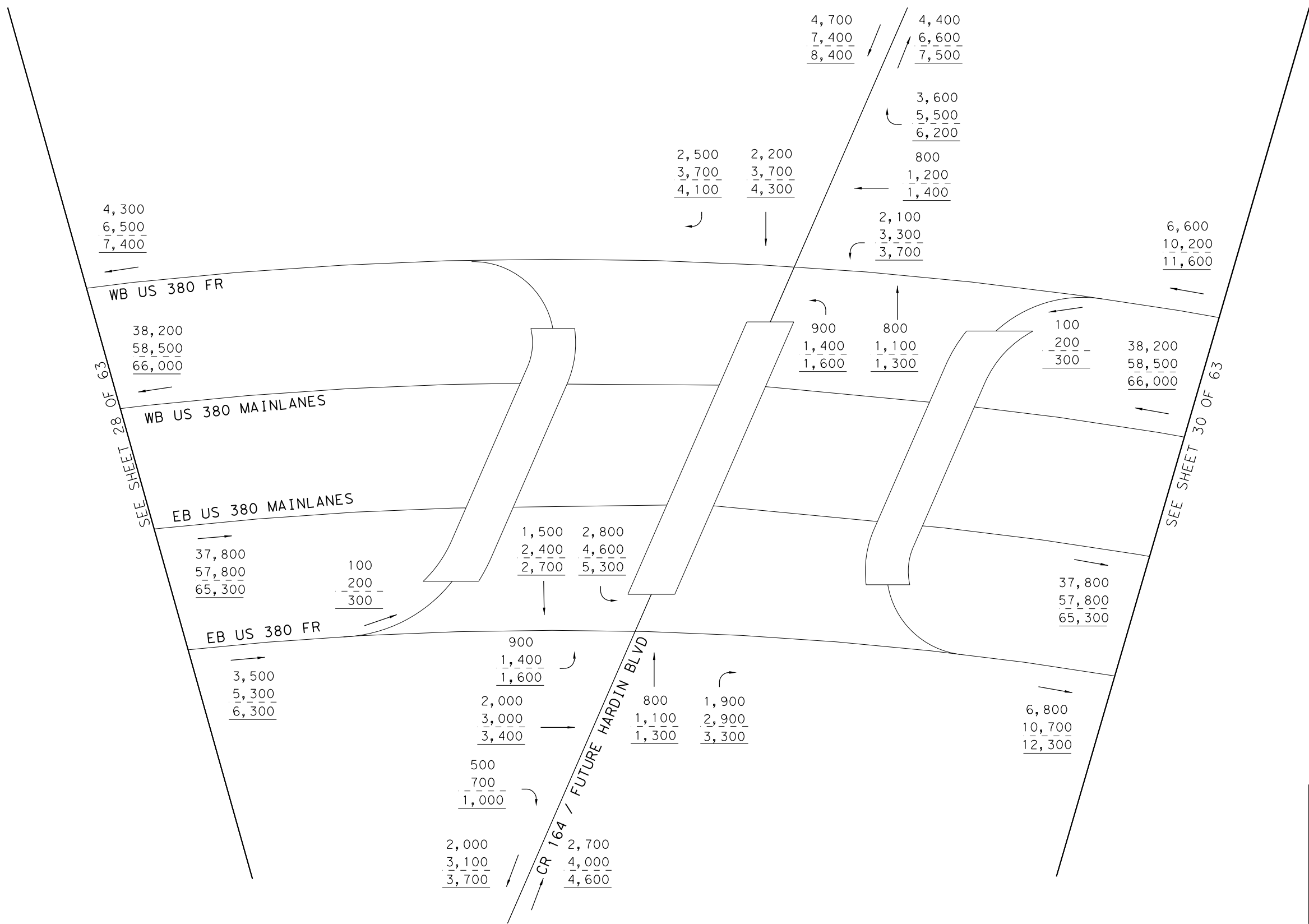


0135-02-065,
ETC.

SHEET 28 OF 63

LEGEND

- XXXX- 2030 AVERAGE DAILY TRAFFIC VOLUMES
- XXXX- 2050 AVERAGE DAILY TRAFFIC VOLUMES
- XXXX- 2060 AVERAGE DAILY TRAFFIC VOLUMES



SEE SHEET 28 OF 63

SEE SHEET 30 OF 63

LEGEND

- XXXX- 2030 AVERAGE DAILY TRAFFIC VOLUMES
- XXXX- 2050 AVERAGE DAILY TRAFFIC VOLUMES
- XXXX- 2060 AVERAGE DAILY TRAFFIC VOLUMES

NOT TO SCALE

NOT INTENDED FOR CONSTRUCTION,
 BIDDING OR PERMIT PURPOSES
 DHRUVA LAHON, P.E.
 SERIAL NUMBER 102185

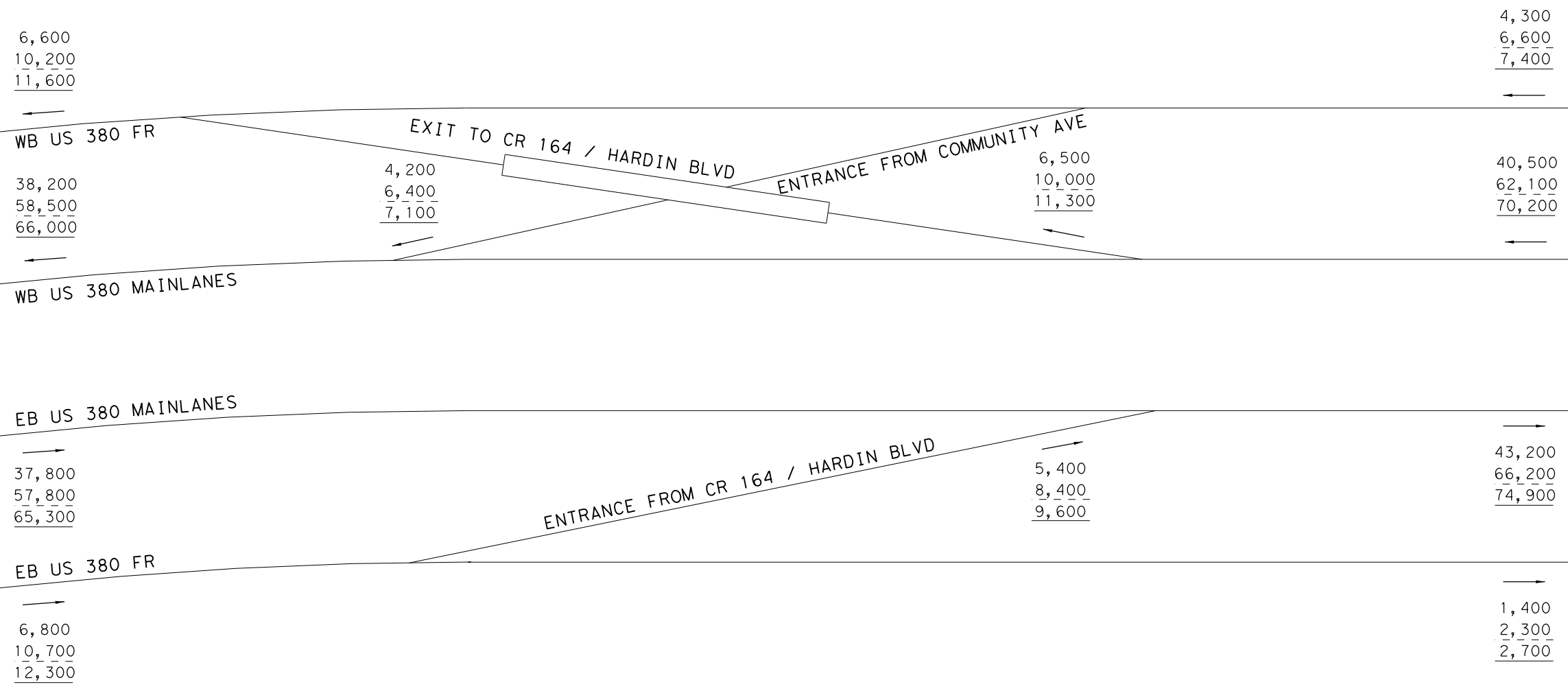
US 380 BLUE ALT AND
 CR 164
 AVERAGE DAILY TRAFFIC
 BLUE ALT BUILD VOLUMES





SEE SHEET 29 OF 63

SEE SHEET 31 OF 63



LEGEND

- XXXX- 2030 AVERAGE DAILY TRAFFIC VOLUMES
- XXXX- 2050 AVERAGE DAILY TRAFFIC VOLUMES
- XXXX- 2060 AVERAGE DAILY TRAFFIC VOLUMES

NOT TO SCALE

NOT INTENDED FOR CONSTRUCTION,
 BIDDING OR PERMIT PURPOSES
 DHRUVA LAHON, P.E.
 SERIAL NUMBER 102185

US 380 BLUE ALT AND
 RAMPS
 AVERAGE DAILY TRAFFIC
 BLUE ALT BUILD VOLUMES

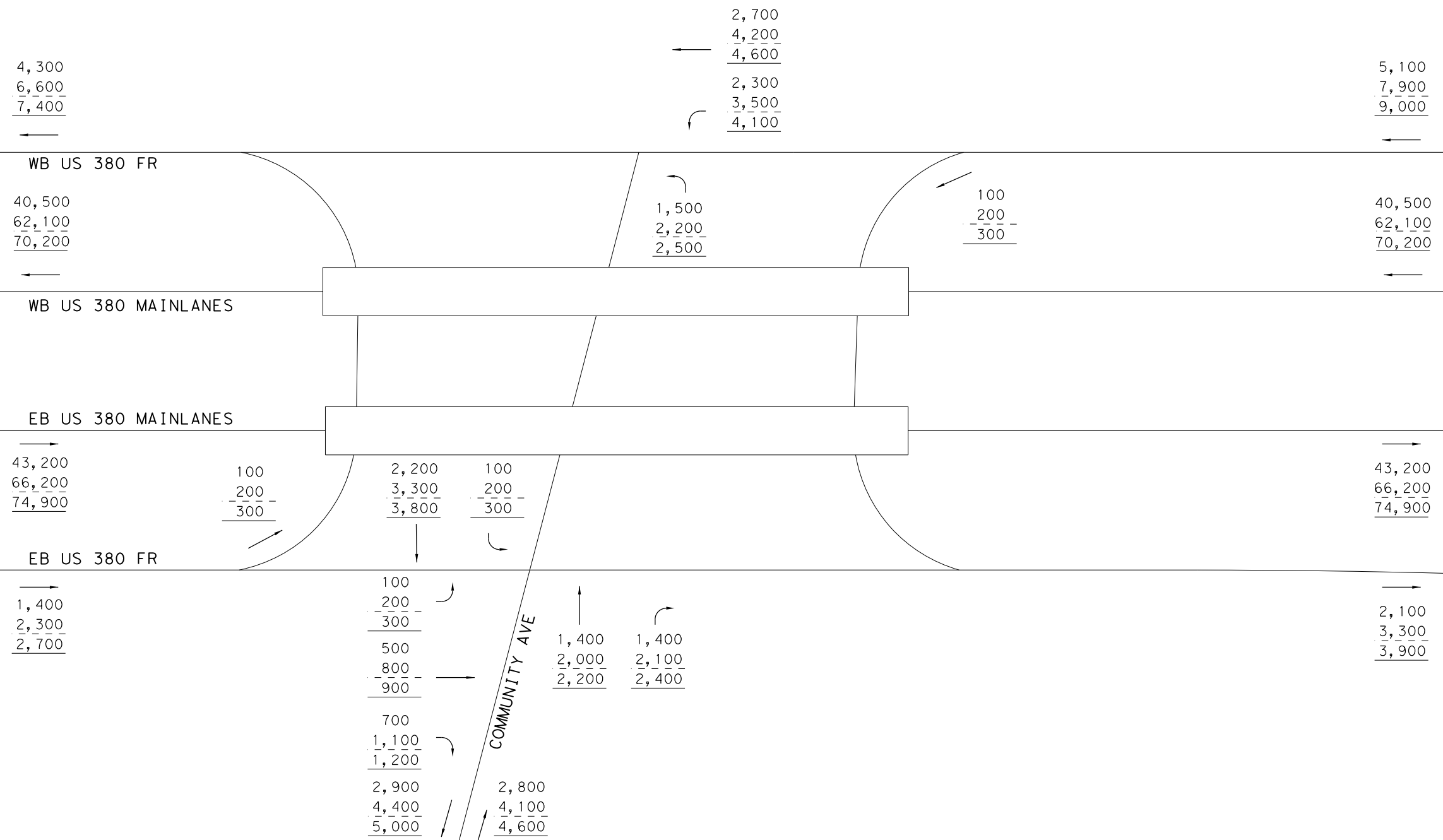


DATE: 7/13/2021
 FILE: US380_BLUE_TRF_30.dgn



SEE SHEET 30 OF 63

SEE SHEET 32 OF 63



NOT TO SCALE

NOT INTENDED FOR CONSTRUCTION,
 BIDDING OR PERMIT PURPOSES
 DHRUVA LAHON, P.E.
 SERIAL NUMBER 102185

US 380 BLUE ALT AND
 COMMUNITY AVE
 AVERAGE DAILY TRAFFIC
 BLUE ALT BUILD VOLUMES

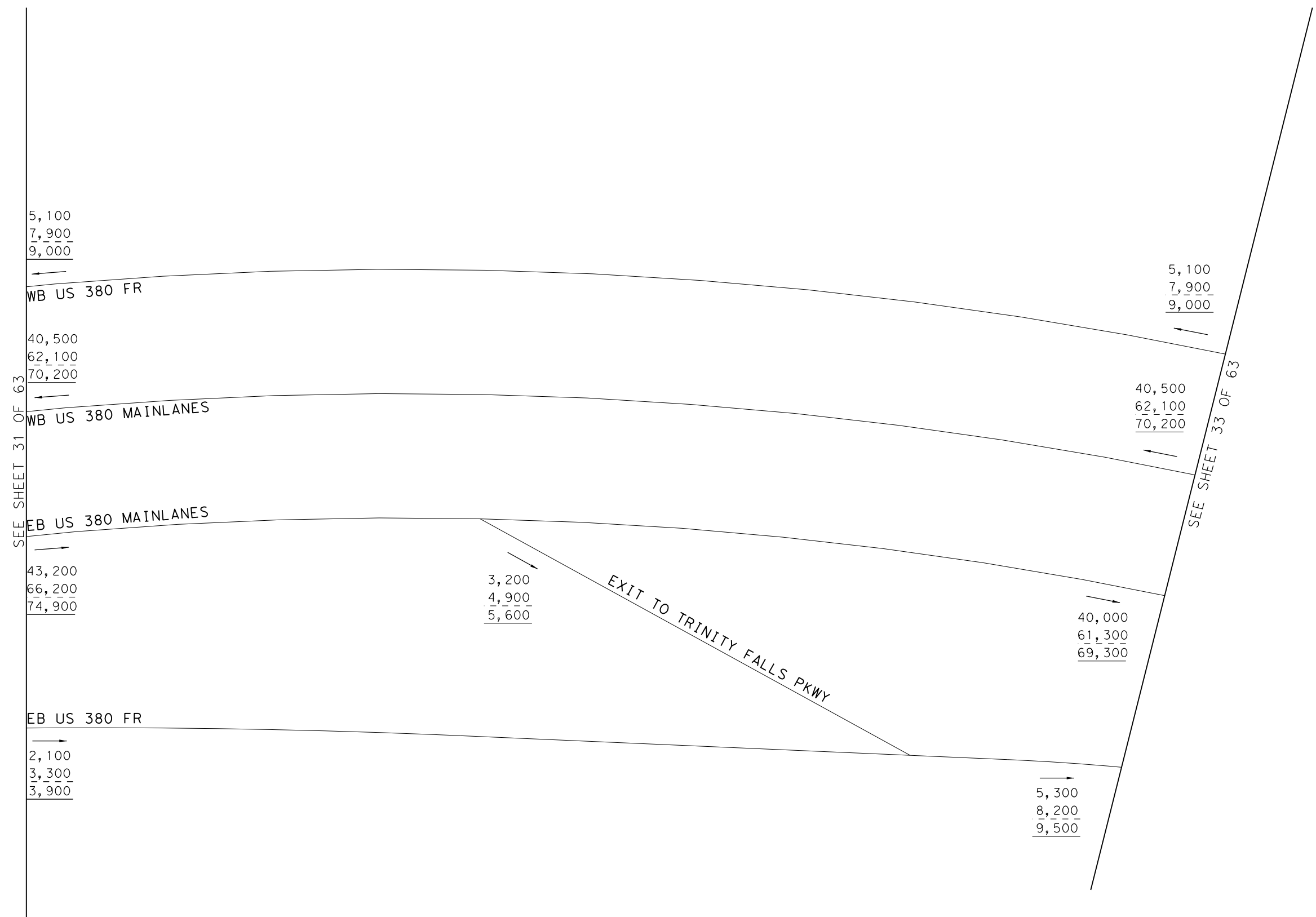


0135-02-065,
 ETC. SHEET 31 OF 63

LEGEND

- XXXX- 2030 AVERAGE DAILY TRAFFIC VOLUMES
- XXXX- 2050 AVERAGE DAILY TRAFFIC VOLUMES
- XXXX- 2060 AVERAGE DAILY TRAFFIC VOLUMES

DATE: 7/13/2021
 FILE: US380_BLUE_TRF_31.dgn



SEE SHEET 31 OF 63

SEE SHEET 33 OF 63

LEGEND

XXXX-	2030	AVERAGE	DAILY	TRAFFIC	VOLUMES
- XXXX-	2050	AVERAGE	DAILY	TRAFFIC	VOLUMES
- XXXX-	2060	AVERAGE	DAILY	TRAFFIC	VOLUMES

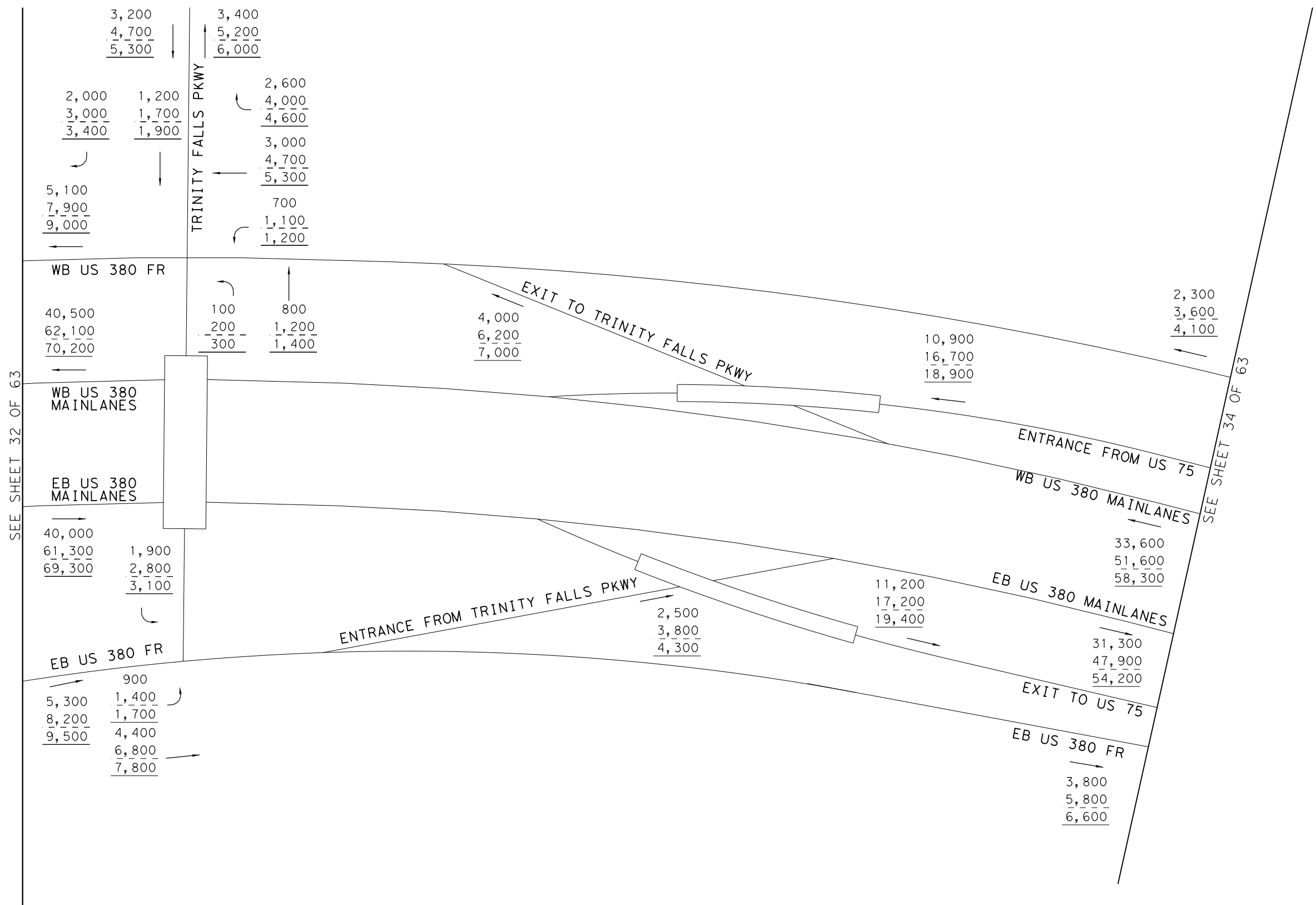
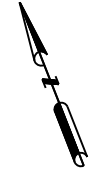
NOT TO SCALE

NOT INTENDED FOR CONSTRUCTION,
 BIDDING OR PERMIT PURPOSES
 DHRUVA LAHON, P.E.
 SERIAL NUMBER 102185

US 380 BLUE ALT AND
 RAMPS
 AVERAGE DAILY TRAFFIC
 BLUE ALT BUILD VOLUMES



DATE: 7/13/2021
 FILE: US380_BLUE_TRF_32.dgn



SEE SHEET 32 OF 63

SEE SHEET 34 OF 63

LEGEND

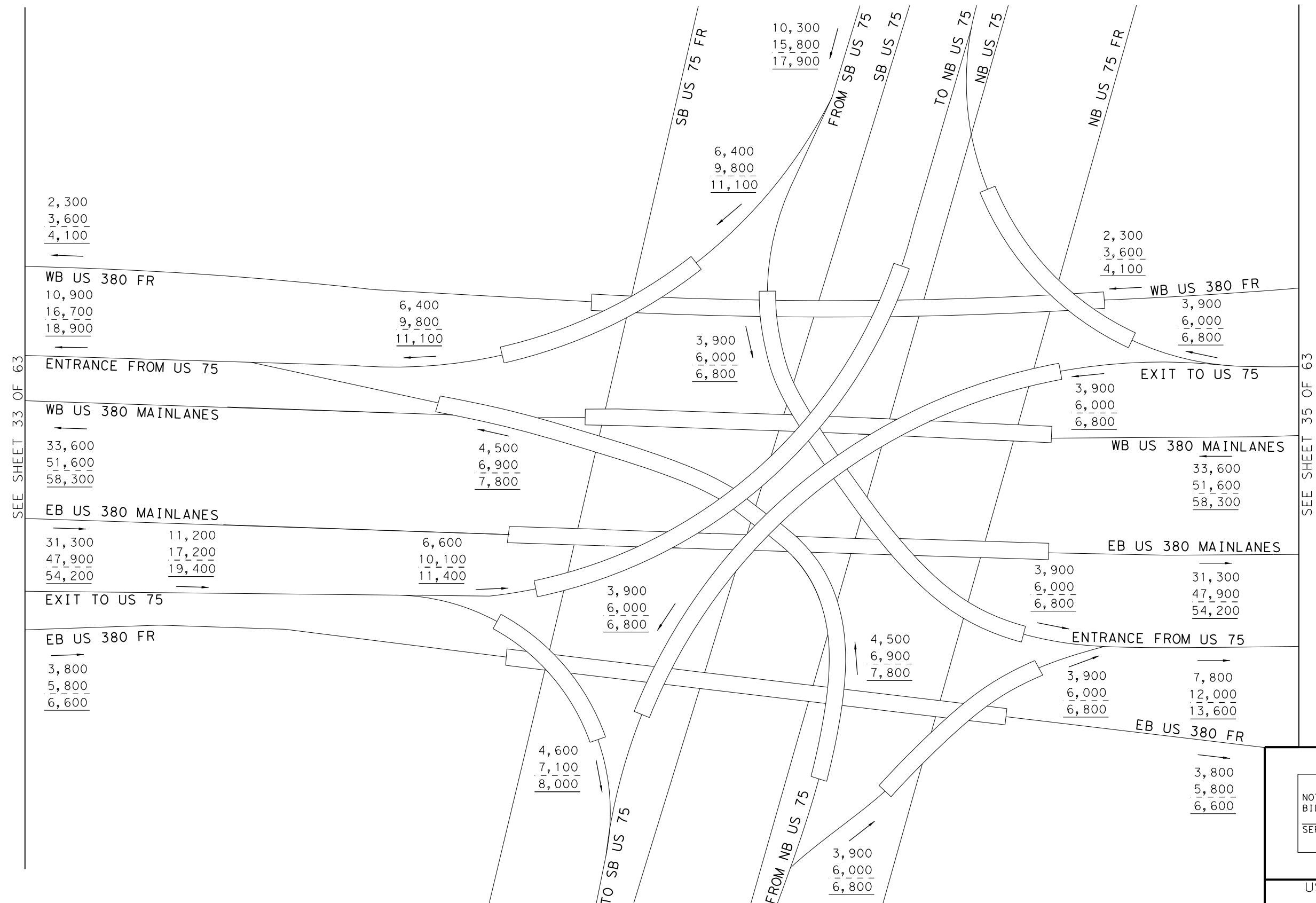
- XXXX- 2030 AVERAGE DAILY TRAFFIC VOLUMES
- XXXX- 2050 AVERAGE DAILY TRAFFIC VOLUMES
- XXXX- 2060 AVERAGE DAILY TRAFFIC VOLUMES

NOT TO SCALE

NOT INTENDED FOR CONSTRUCTION,
BIDDING OR PERMIT PURPOSES
DHURVA LAHON, P.E.
SERIAL NUMBER 102185

US 380 BLUE ALT AND
TRINITY FALLS PKWY
AVERAGE DAILY TRAFFIC
BLUE ALT BUILD VOLUMES





NOT TO SCALE

NOT INTENDED FOR CONSTRUCTION,
 BIDDING OR PERMIT PURPOSES
 DHRUVA LAHON, P.E.
 SERIAL NUMBER 102185

US 380 BLUE ALT AND
 US 75
 AVERAGE DAILY TRAFFIC
 BLUE ALT BUILD VOLUMES

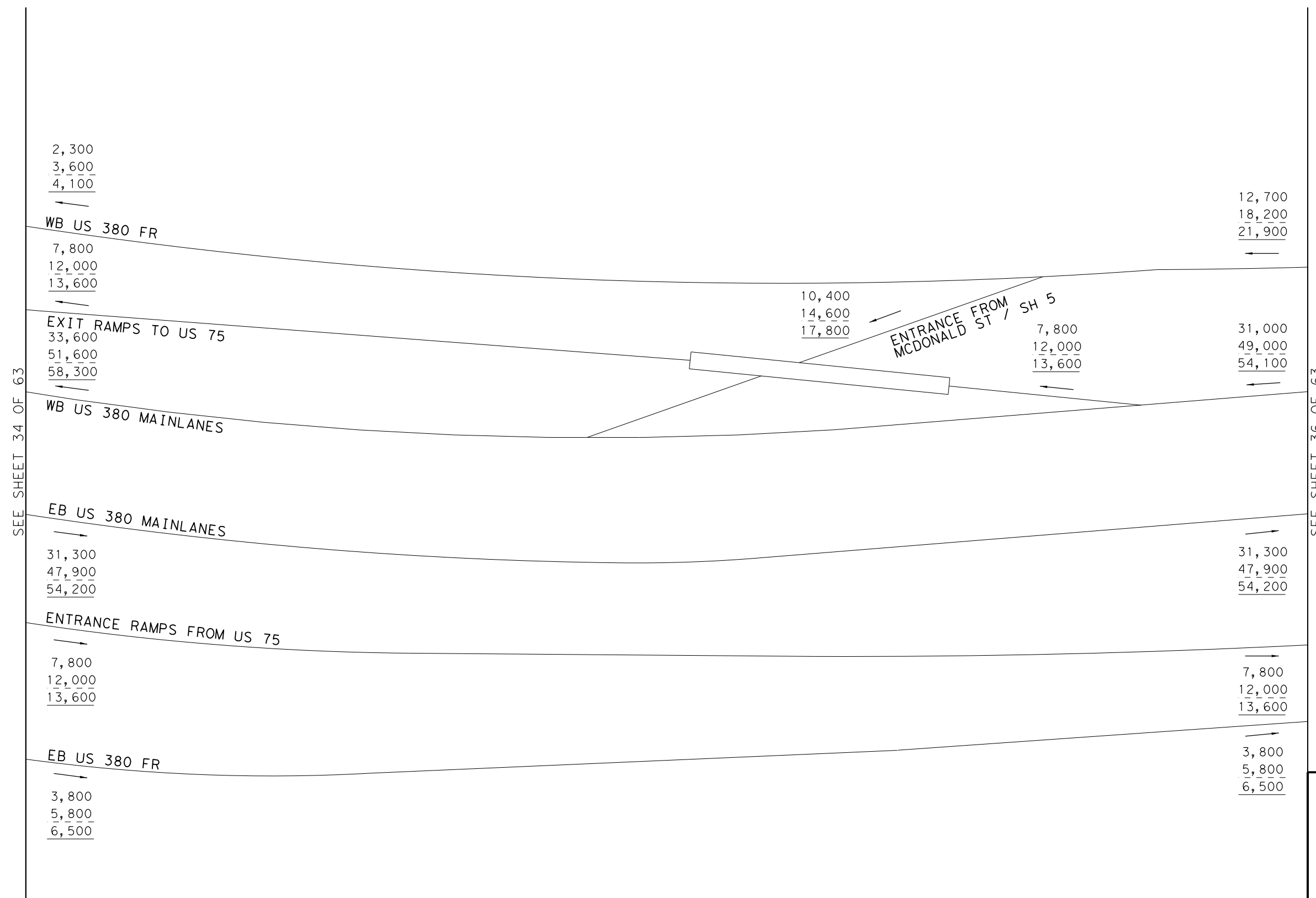
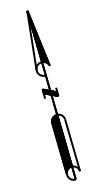


0135-02-065,
 ETC. SHEET 34 OF 63

LEGEND

- XXXX- 2030 AVERAGE DAILY TRAFFIC VOLUMES
- XXXX- 2050 AVERAGE DAILY TRAFFIC VOLUMES
- XXXX- 2060 AVERAGE DAILY TRAFFIC VOLUMES

DATE: 7/13/2021
 FILE: US380_BLUE_TRF_34.dgn



SEE SHEET 34 OF 63

SEE SHEET 36 OF 63

NOT TO SCALE

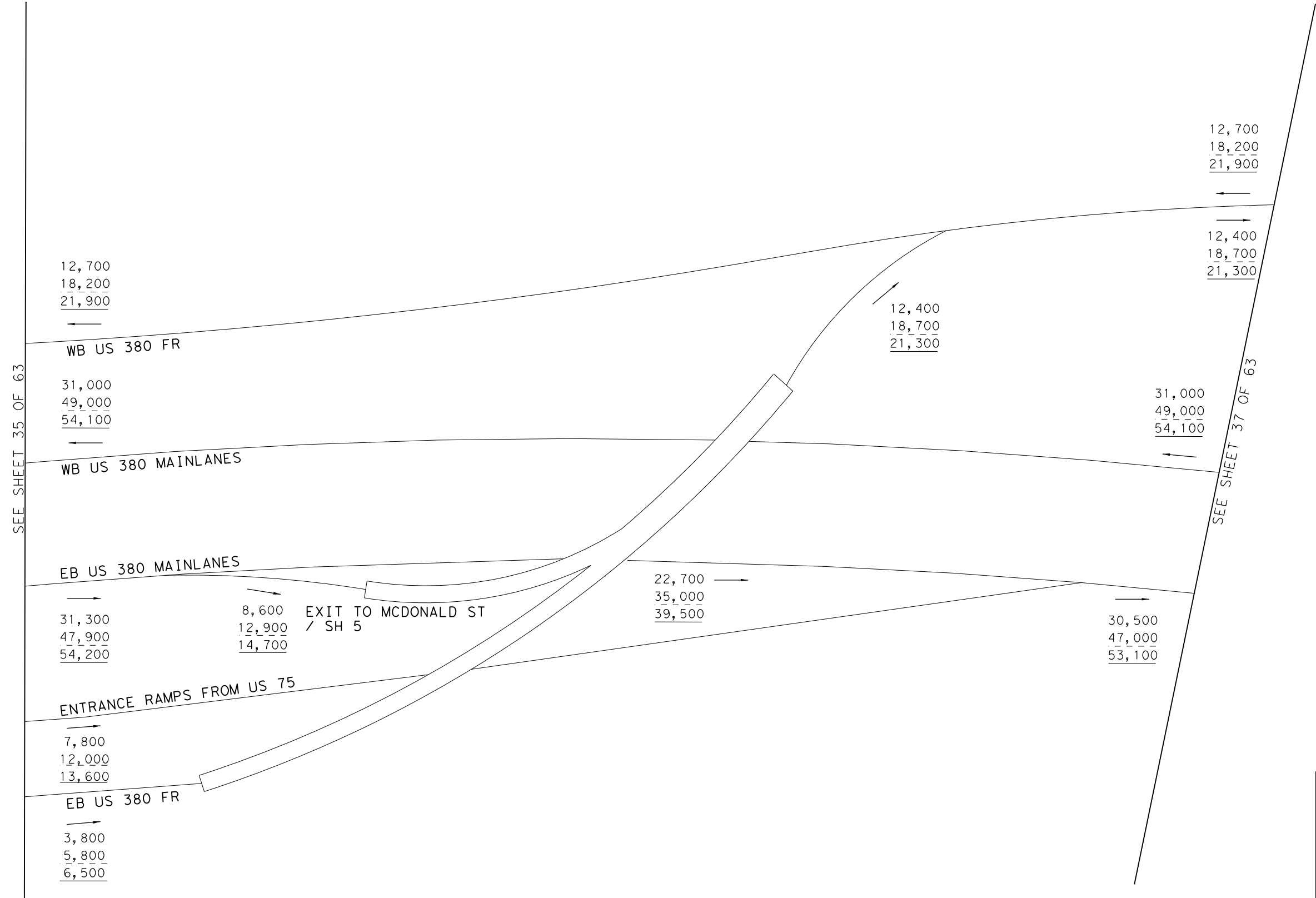
NOT INTENDED FOR CONSTRUCTION,
 BIDDING OR PERMIT PURPOSES
 DHRUVA LAHON, P.E.
 SERIAL NUMBER 102185

US 380 BLUE ALT AND
 WESTON RD
 AVERAGE DAILY TRAFFIC
 BLUE ALT BUILD VOLUMES



LEGEND

- XXXX- 2030 AVERAGE DAILY TRAFFIC VOLUMES
- XXXX- 2050 AVERAGE DAILY TRAFFIC VOLUMES
- XXXX- 2060 AVERAGE DAILY TRAFFIC VOLUMES



SEE SHEET 35 OF 63

SEE SHEET 37 OF 63

NOT TO SCALE

NOT INTENDED FOR CONSTRUCTION,
 BIDDING OR PERMIT PURPOSES
 DHRUVA LAHON, P.E.
 SERIAL NUMBER 102185

US 380 BLUE ALT AND
 RAMPS
 AVERAGE DAILY TRAFFIC
 BLUE ALT BUILD VOLUMES

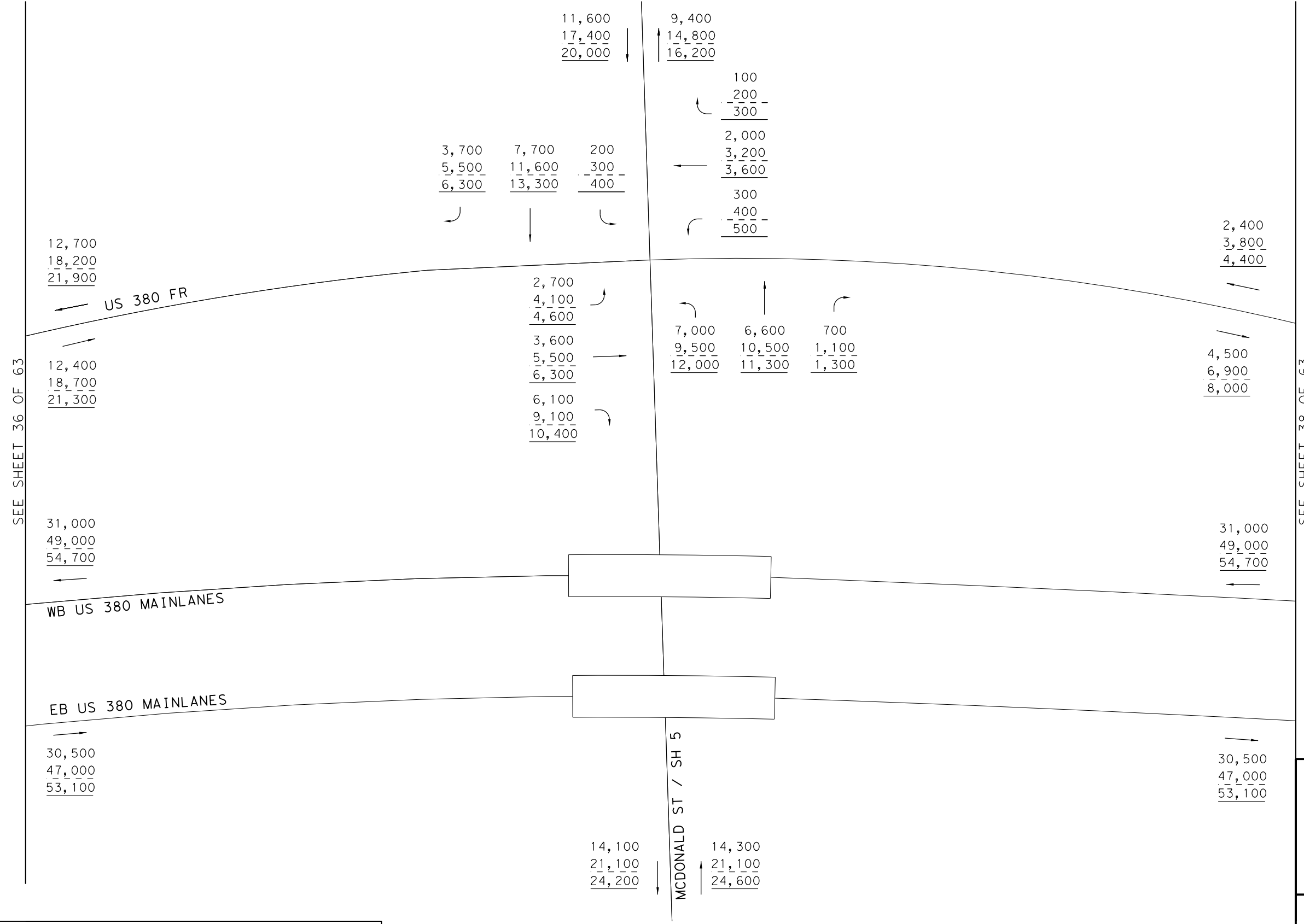
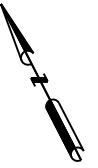


0135-02-065,
 ETC. SHEET 36 OF 63

LEGEND

- XXXX- 2030 AVERAGE DAILY TRAFFIC VOLUMES
- XXXX- 2050 AVERAGE DAILY TRAFFIC VOLUMES
- XXXX- 2060 AVERAGE DAILY TRAFFIC VOLUMES

DATE: 7/13/2021
 FILE: US380_BLUE_TRF_36.dgn



SEE SHEET 36 OF 63

SEE SHEET 38 OF 63

NOT TO SCALE

NOT INTENDED FOR CONSTRUCTION,
 BIDDING OR PERMIT PURPOSES
 DHRUVA LAHON, P.E.
 SERIAL NUMBER 102185

US 380 BLUE ALT AND
 MCDONALD ST/ SH 5
 AVERAGE DAILY TRAFFIC
 BLUE ALT BUILD VOLUMES

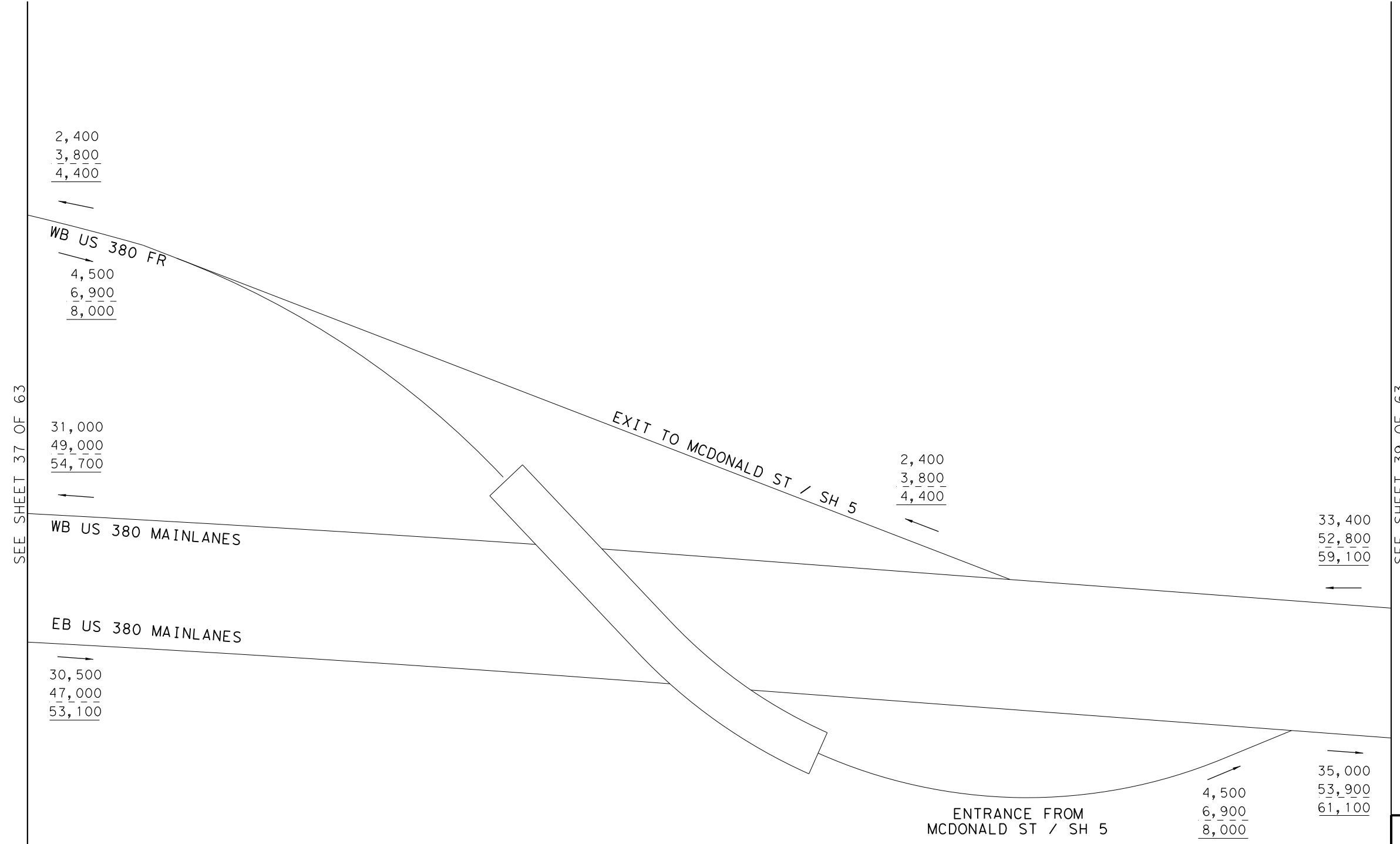
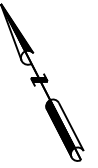


0135-02-065,
 ETC. SHEET 37 OF 63

LEGEND

- XXXX- 2030 AVERAGE DAILY TRAFFIC VOLUMES
- XXXX- 2050 AVERAGE DAILY TRAFFIC VOLUMES
- XXXX- 2060 AVERAGE DAILY TRAFFIC VOLUMES

DATE: 7/13/2021
 FILE: US380_BLUE_TRF_37.dgn



SEE SHEET 37 OF 63

SEE SHEET 39 OF 63

NOT TO SCALE

NOT INTENDED FOR CONSTRUCTION,
 BIDDING OR PERMIT PURPOSES
 DHRUVA LAHON, P.E.
 SERIAL NUMBER 102185

US 380 BLUE ALT AND
 RAMP
 AVERAGE DAILY TRAFFIC
 BLUE ALT BUILD VOLUMES

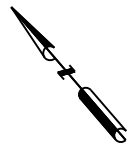


0135-02-065,
 ETC. SHEET 38 OF 63

LEGEND

- XXXX- 2030 AVERAGE DAILY TRAFFIC VOLUMES
- XX- 2050 AVERAGE DAILY TRAFFIC VOLUMES
- XX- 2060 AVERAGE DAILY TRAFFIC VOLUMES

DATE: 7/13/2021
 FILE: US380_BLUE_TRF_38.dgn



SEE SHEET 38 OF 63

33,400
52,800
59,100

WB US 380 MAINLANES

35,000
53,900
61,100

EB US 380 MAINLANES

4,400
6,800
8,000

ENTRANCE FROM CR 338

2,100
3,200
3,700

EXIT TO CR 338

29,000
46,000
51,100

32,900
50,700
57,400

SEE SHEET 40 OF 63

NOT TO SCALE

NOT INTENDED FOR CONSTRUCTION,
BIDDING OR PERMIT PURPOSES
DHURVA LAHON, P.E.
SERIAL NUMBER 102185

US 380 BLUE ALT AND
RAMPS
AVERAGE DAILY TRAFFIC
BLUE ALT BUILD VOLUMES

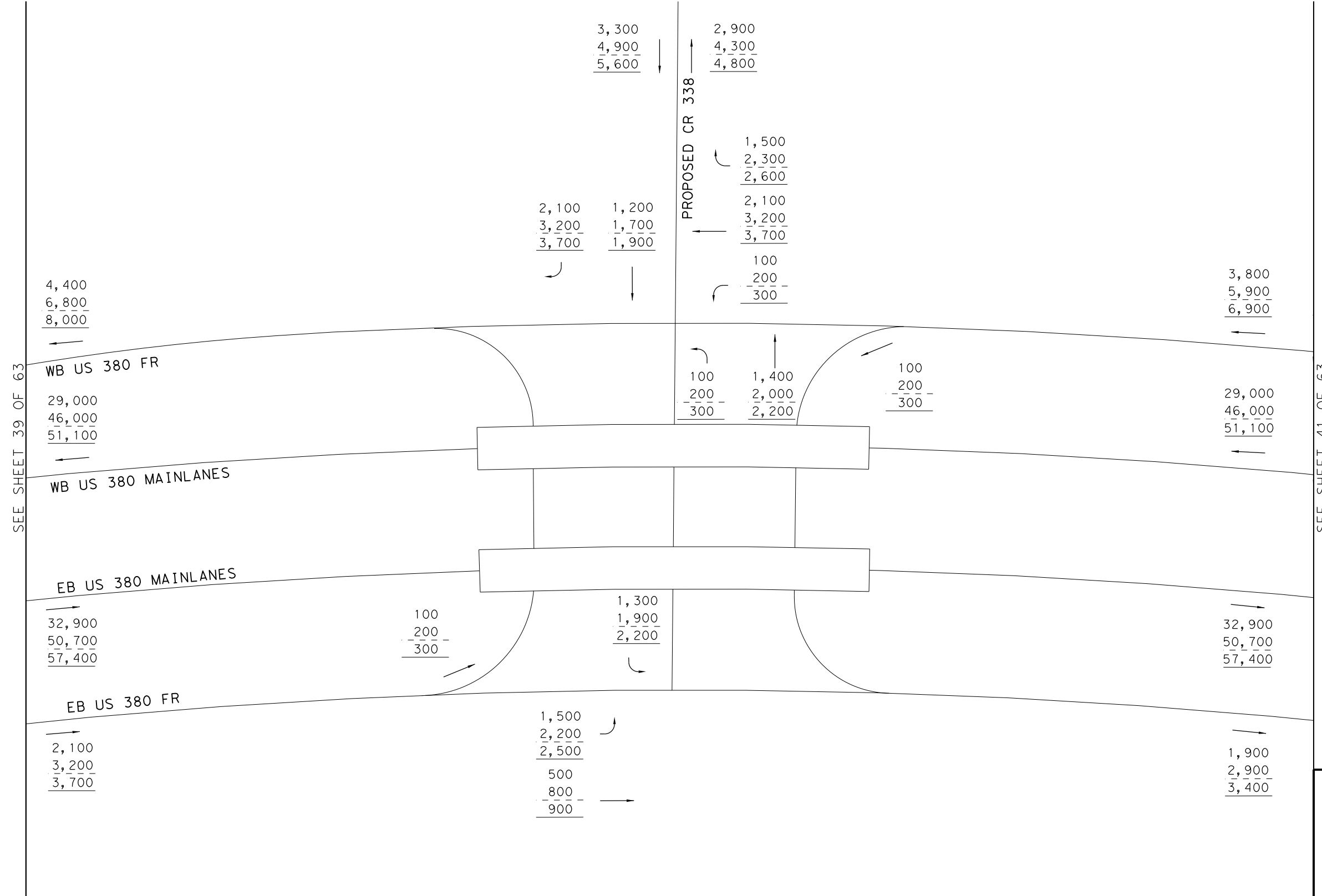
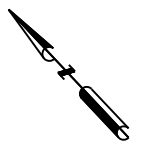
Kimley»Horn
F-928

0135-02-065,
ETC. SHEET 39 OF 63

LEGEND

- XXXX- 2030 AVERAGE DAILY TRAFFIC VOLUMES
- XXXX- 2050 AVERAGE DAILY TRAFFIC VOLUMES
- XXXX- 2060 AVERAGE DAILY TRAFFIC VOLUMES

DATE: 7/13/2021
FILE: US380_BLUE_TRF_39.dgn



SEE SHEET 39 OF 63

SEE SHEET 41 OF 63

NOT TO SCALE

NOT INTENDED FOR CONSTRUCTION,
 BIDDING OR PERMIT PURPOSES
 DHRUVA LAHON, P.E.
 SERIAL NUMBER 102185

US 380 BLUE ALT AND
 CR 338
 AVERAGE DAILY TRAFFIC
 BLUE ALT BUILD VOLUMES

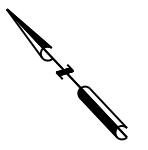


0135-02-065,
 ETC. SHEET 40 OF 63

LEGEND

- XXXX** - 2030 AVERAGE DAILY TRAFFIC VOLUMES
- XXXX - 2050 AVERAGE DAILY TRAFFIC VOLUMES
- XXXX - 2060 AVERAGE DAILY TRAFFIC VOLUMES

DATE: 7/13/2021
 FILE: US380_BLUE_TRF_40.dgn



SEE SHEET 40 OF 63

SEE SHEET 42 OF 63

NOT TO SCALE

NOT INTENDED FOR CONSTRUCTION,
BIDDING OR PERMIT PURPOSES
DHURVA LAHON, P.E.
SERIAL NUMBER 102185

US 380 BLUE ALT AND
RAMPS
AVERAGE DAILY TRAFFIC
BLUE ALT BUILD VOLUMES



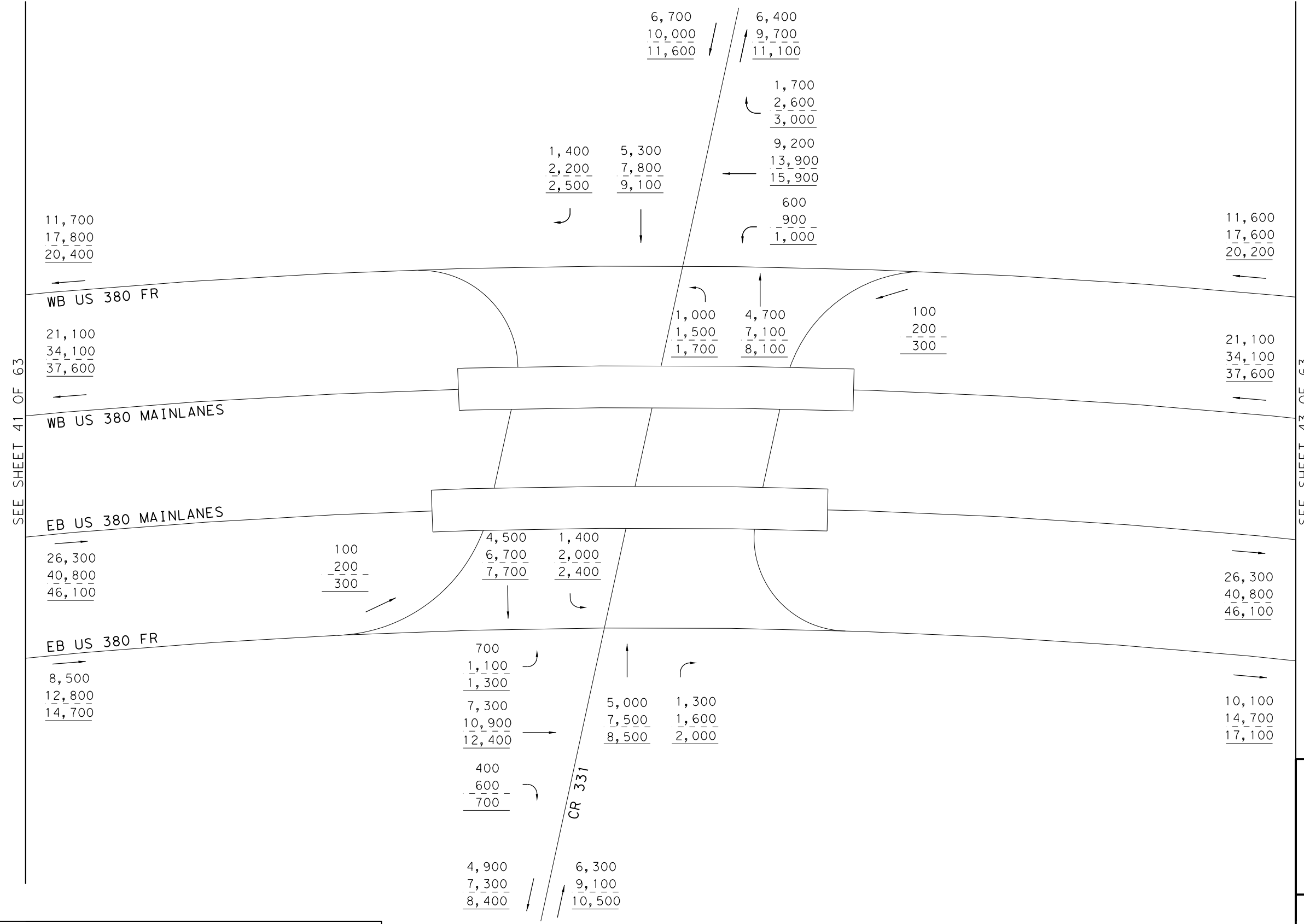
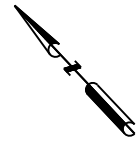
0135-02-065,
ETC.

SHEET 41 OF 63

LEGEND

- XXXX- 2030 AVERAGE DAILY TRAFFIC VOLUMES
- XXXX- 2050 AVERAGE DAILY TRAFFIC VOLUMES
- XXXX- 2060 AVERAGE DAILY TRAFFIC VOLUMES

DATE: 7/13/2021
FILE: US380_BLUE_TRF_41.dgn



SEE SHEET 41 OF 63

SEE SHEET 43 OF 63

NOT TO SCALE

NOT INTENDED FOR CONSTRUCTION,
 BIDDING OR PERMIT PURPOSES
 DHRUVA LAHON, P.E.
 SERIAL NUMBER 102185

US 380 BLUE ALT AND
 CR 331
 AVERAGE DAILY TRAFFIC
 BLUE ALT BUILD VOLUMES

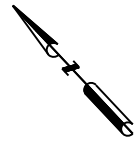


0135-02-065,
 ETC. SHEET 42 OF 63

LEGEND

- XXXX- 2030 AVERAGE DAILY TRAFFIC VOLUMES
- XXXX- 2050 AVERAGE DAILY TRAFFIC VOLUMES
- XXXX- 2060 AVERAGE DAILY TRAFFIC VOLUMES

DATE: 7/13/2021
 FILE: US380_BLUE_TRF_42.dgn



SEE SHEET 42 OF 63

SEE SHEET 44 OF 63

11,600
17,600
20,200

WB US 380 FR

21,100
34,100
37,600

WB US 380 MAINLANES

EB US 380 MAINLANES

26,300
40,800
46,100

EB US 380 FR

10,100
14,700
17,100

8,600
13,100
15,100

24,100
38,600
42,700

30,100
46,500
52,600

6,300
9,000
10,600

EXIT TO CR 331

3,000
4,500
5,100

ENTRANCE FROM CR 331

3,800
5,700
6,500

NOT TO SCALE

NOT INTENDED FOR CONSTRUCTION,
BIDDING OR PERMIT PURPOSES
DHURVA LAHON, P.E.
SERIAL NUMBER 102185

US 380 BLUE ALT AND
RAMPS
AVERAGE DAILY TRAFFIC
BLUE ALT BUILD VOLUMES

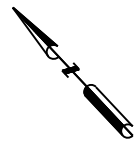
Kimley»Horn
F-928

0135-02-065,
ETC.

SHEET 43 OF 63

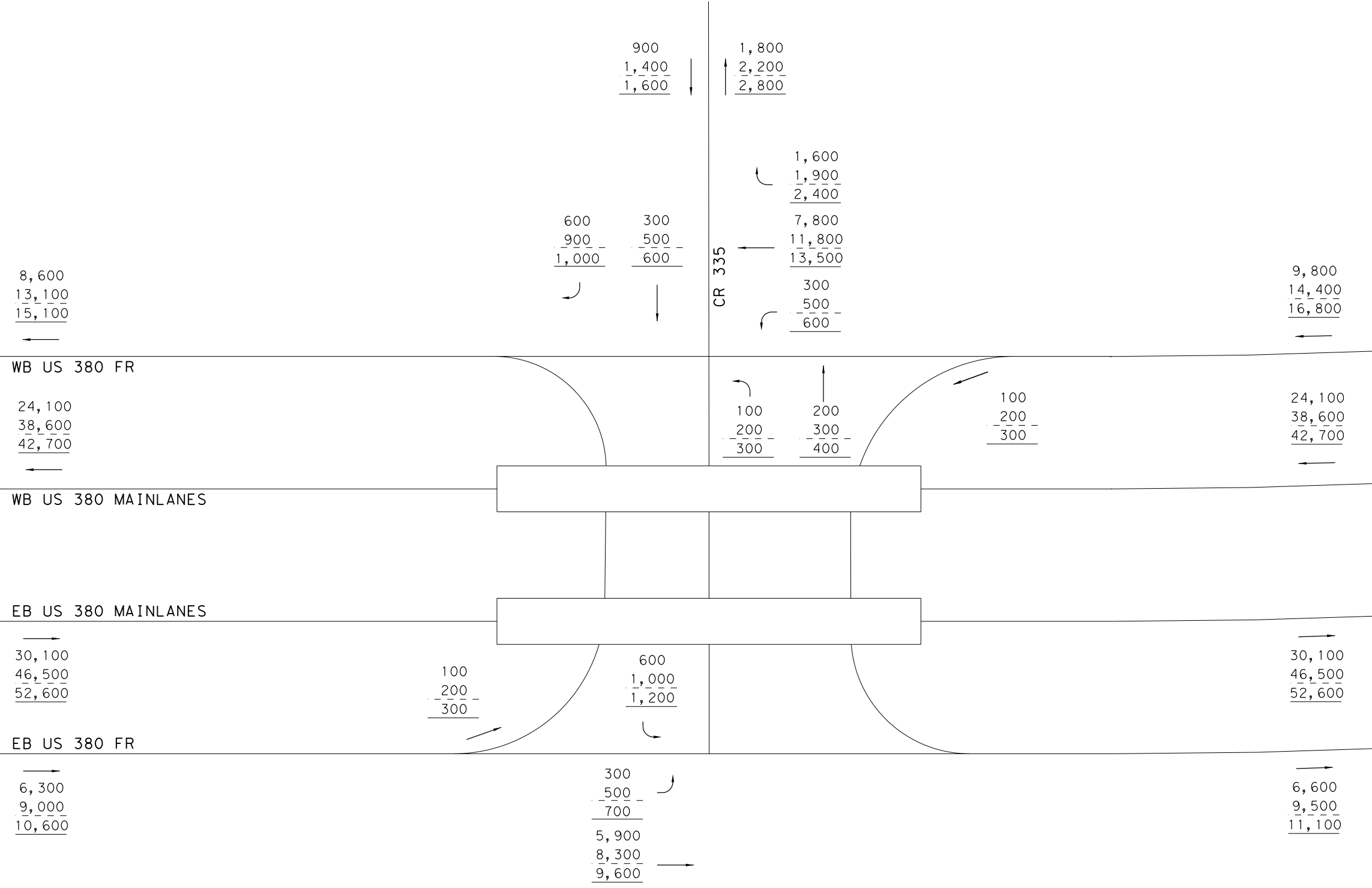
LEGEND

- XXXX- 2030 AVERAGE DAILY TRAFFIC VOLUMES
- XXXX- 2050 AVERAGE DAILY TRAFFIC VOLUMES
- XXXX- 2060 AVERAGE DAILY TRAFFIC VOLUMES



SEE SHEET 43 OF 63

SEE SHEET 44A OF 63



NOT TO SCALE

NOT INTENDED FOR CONSTRUCTION,
 BIDDING OR PERMIT PURPOSES
 DHRUVA LAHON, P.E.
 SERIAL NUMBER 102185

US 380 BLUE ALT AND
 CR 335
 AVERAGE DAILY TRAFFIC
 BLUE ALT BUILD VOLUMES

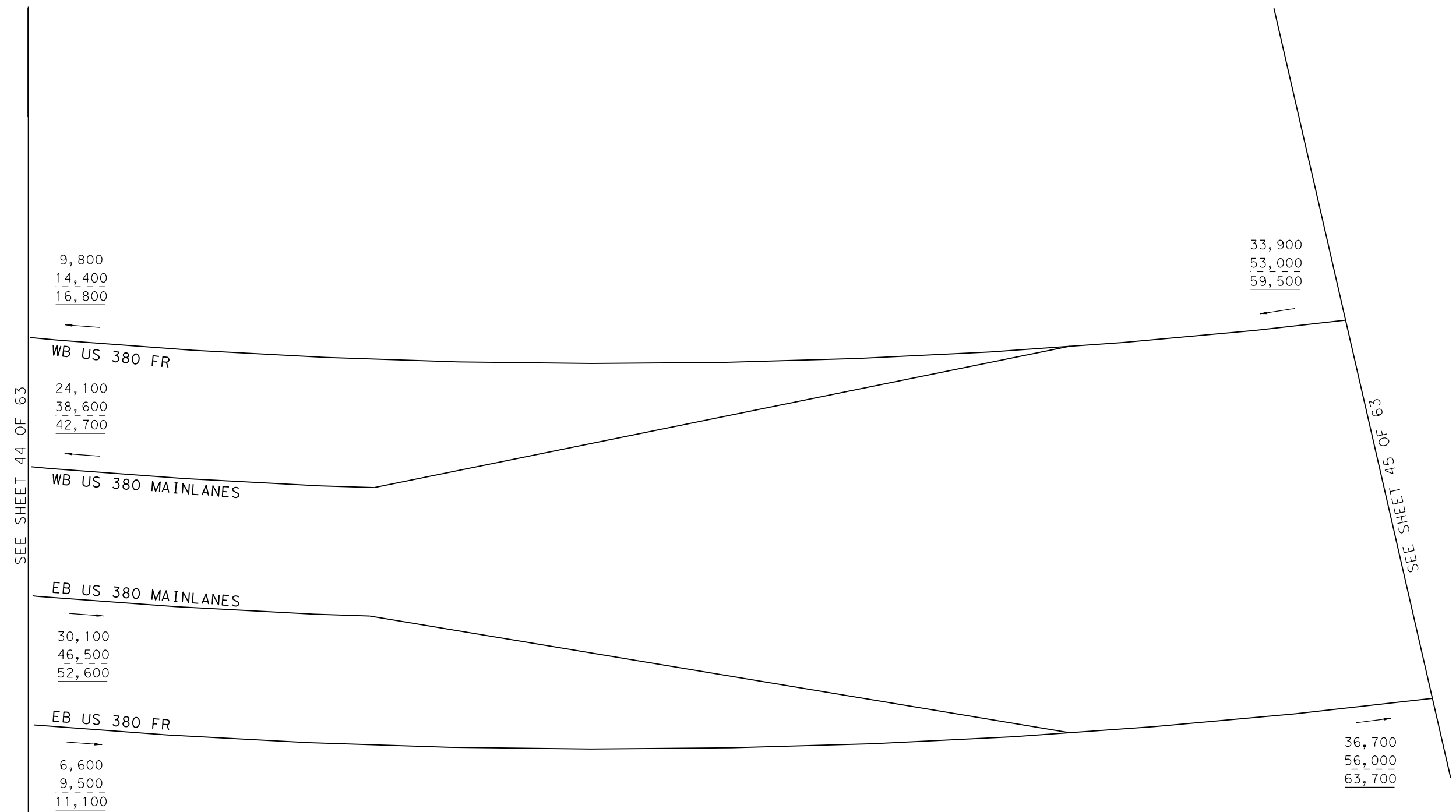
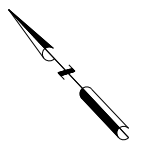


0135-02-065,
 ETC. SHEET 44 OF 63

LEGEND

- XXXX- 2030 AVERAGE DAILY TRAFFIC VOLUMES
- XXXX- 2050 AVERAGE DAILY TRAFFIC VOLUMES
- XXXX- 2060 AVERAGE DAILY TRAFFIC VOLUMES

DATE: 7/13/2021
 FILE: US380_BLUE_TRF_44.dgn



33,900
53,000
59,500

36,700
56,000
63,700

SEE SHEET 44 OF 63

SEE SHEET 45 OF 63

NOT TO SCALE

NOT INTENDED FOR CONSTRUCTION,
BIDDING OR PERMIT PURPOSES
DHURVA LAHON, P.E.
SERIAL NUMBER 102185

US 380 BLUE ALT AND
RAMPS
AVERAGE DAILY TRAFFIC
BLUE ALT BUILD VOLUMES

Kimley»Horn
F-928

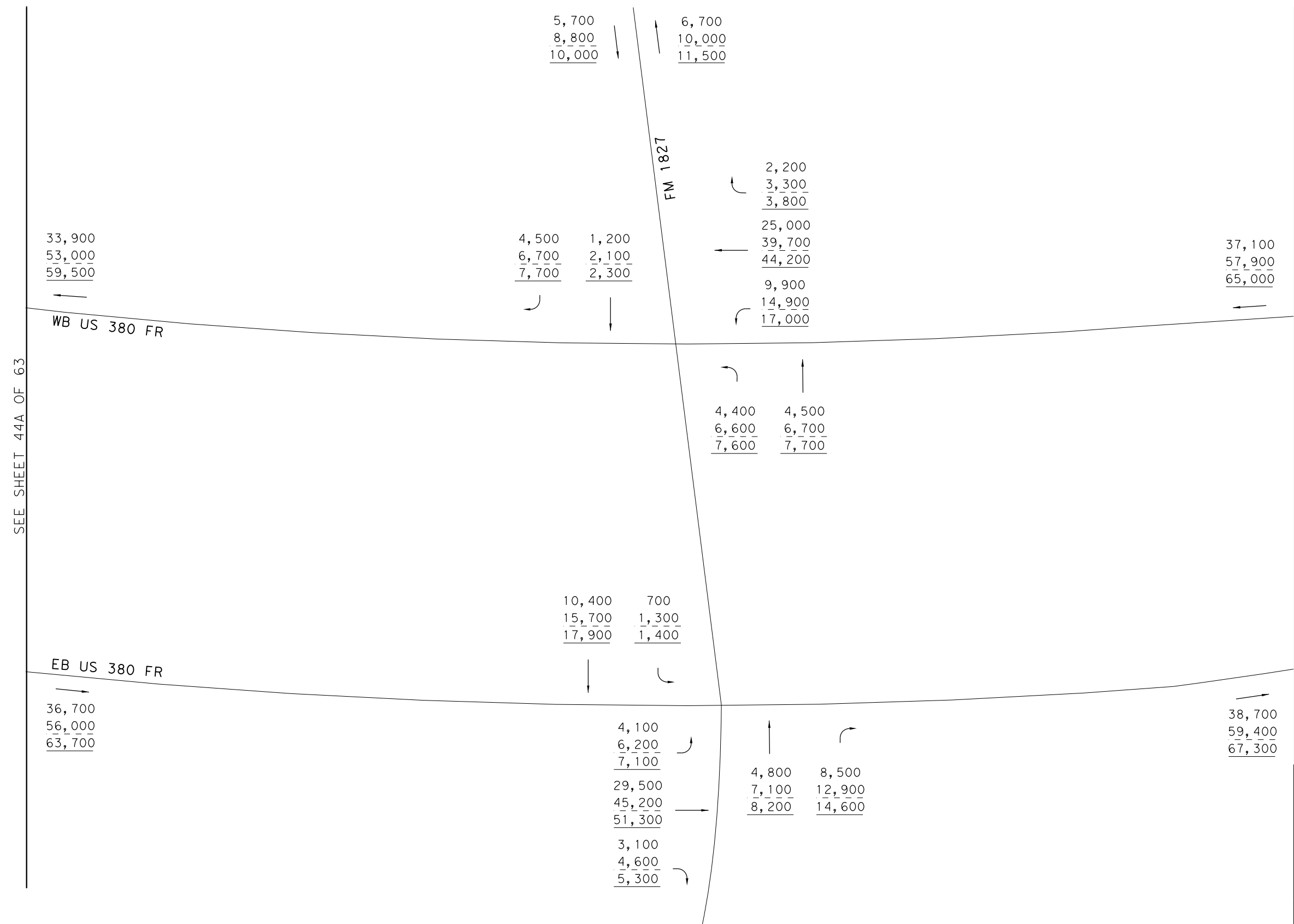
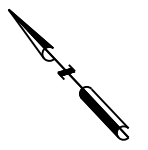
0135-02-065,
ETC. SHEET 44A OF 63

LEGEND

- XXXX- 2030 AVERAGE DAILY TRAFFIC VOLUMES
- XXXX- 2050 AVERAGE DAILY TRAFFIC VOLUMES
- XXXX- 2060 AVERAGE DAILY TRAFFIC VOLUMES

NOTE: SEE US 380 PRINCETON PROJECT
FOR US 380, FROM FM 1827 EASTWARD

DATE: 7/13/2021
FILE: US380_BLUE_TRF_44a.dgn



SEE SHEET 44A OF 63

SEE SHEET 46 OF 63

SEE SHEET 63 OF 63

NOT TO SCALE

NOT INTENDED FOR CONSTRUCTION,
 BIDDING OR PERMIT PURPOSES
 DHRUVA LAHON, P.E.
 SERIAL NUMBER 102185

US 380 BLUE ALT AND
 NEW HOPE ROAD/ FM 1827
 AVERAGE DAILY TRAFFIC
 BLUE ALT BUILD VOLUMES



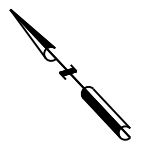
0135-02-065,
 ETC. SHEET 45 OF 63

LEGEND

- XXXX- 2030 AVERAGE DAILY TRAFFIC VOLUMES
- XXXX- 2050 AVERAGE DAILY TRAFFIC VOLUMES
- XXXX- 2060 AVERAGE DAILY TRAFFIC VOLUMES

NOTE: SEE US 380 PRINCETON PROJECT
 FOR US 380, FROM FM 1827 EASTWARD

DATE: 7/13/2021
 FILE: US380_BLUE_TRF_45.dgn



SEE SHEET 45 OF 63

37,100
57,900
65,000

38,700
59,400
67,300

37,100
57,900
65,000

38,700
59,400
67,300

WB US 380 MAINLANES
EB US 380 MAINLANES

LEGEND

- XXXX- 2030 AVERAGE DAILY TRAFFIC VOLUMES
- XXXX- 2050 AVERAGE DAILY TRAFFIC VOLUMES
- XXXX- 2060 AVERAGE DAILY TRAFFIC VOLUMES

NOTE: SEE US 380 PRINCETON PROJECT FOR US 380, FROM FM 1827 EASTWARD

NOT TO SCALE

NOT INTENDED FOR CONSTRUCTION,
BIDDING OR PERMIT PURPOSES
DHURVA LAHON, P.E.
SERIAL NUMBER 102185

US 380 BLUE ALT AND
RAMPS
AVERAGE DAILY TRAFFIC
BLUE ALT BUILD VOLUMES



0135-02-065,
ETC. SHEET 46 OF 63

DATE: 7/13/2021
FILE: US380_BLUE_TRF_46.dgn



SEE SHEET 11A OF 63

SEE SHEET 48 OF 63

13,200
20,300
22,900

11,300
17,300
19,600
4,400
6,800
7,700

15,700
24,100
27,300

WB US 380 EXISTING
EB US 380 EXISTING

13,200
20,300
22,900

10,600
16,300
18,300
2,600
4,000
4,600

1,900 4,700
3,000 7,300
3,300 8,200

15,300
23,600
26,500

7,000
10,800
12,300

6,600
10,300
11,500

RIDGE ROAD

NOT TO SCALE

NOT INTENDED FOR CONSTRUCTION,
BIDDING OR PERMIT PURPOSES
DHURVA LAHON, P.E.
SERIAL NUMBER 102185

EXISTING US 380 AND
RIDGE RD
AVERAGE DAILY TRAFFIC

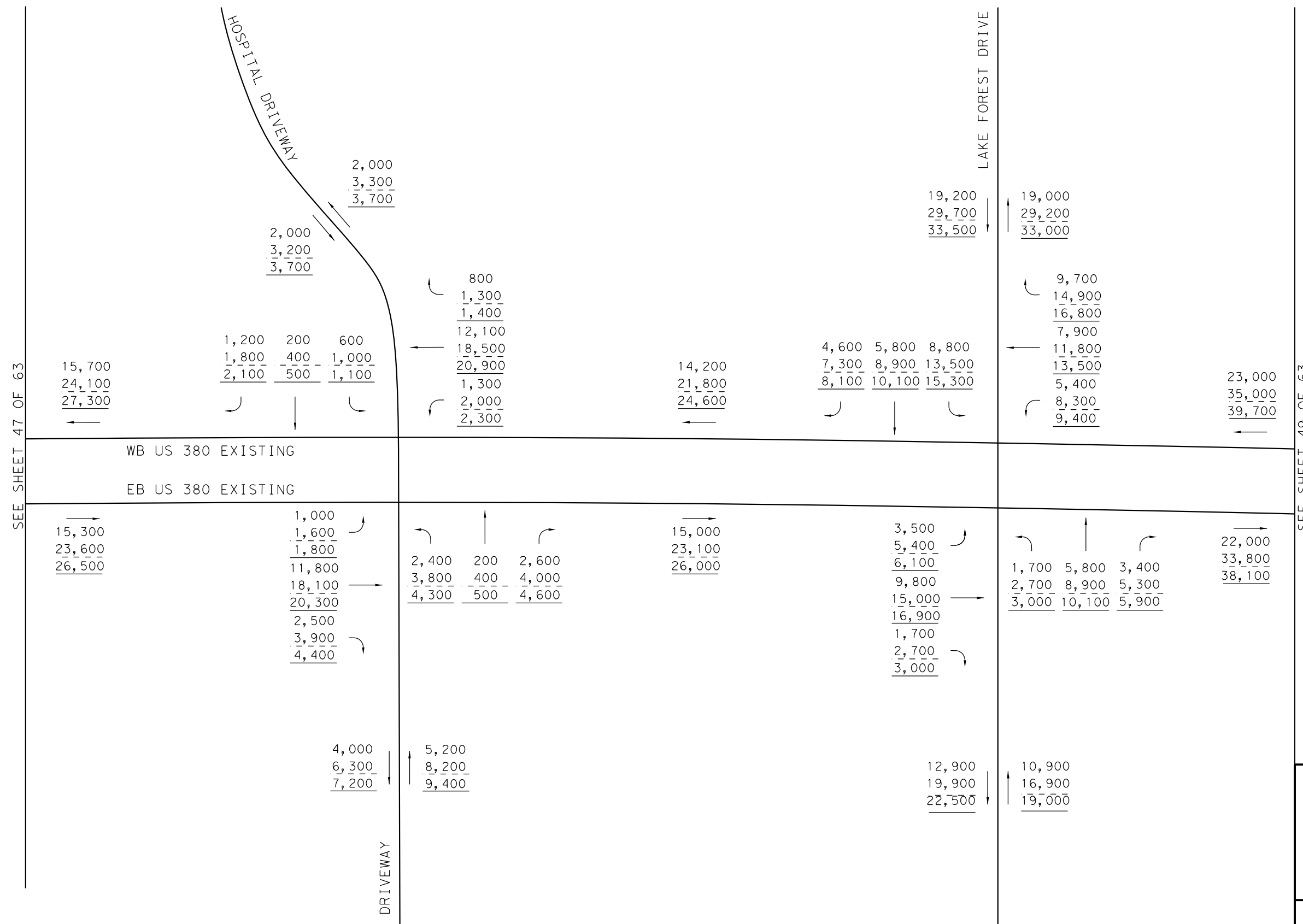
Kimley»Horn
F-928

0135-02-065,
ETC. SHEET 47 OF 63

LEGEND

- XXXX- 2030 AVERAGE DAILY TRAFFIC VOLUMES
- XXXX- 2050 AVERAGE DAILY TRAFFIC VOLUMES
- XXXX- 2060 AVERAGE DAILY TRAFFIC VOLUMES

DATE: 7/13/2021
FILE: US380_BLUE_TRF_47.dgn



SEE SHEET 47 OF 63

SEE SHEET 49 OF 63

WB US 380 EXISTING

EB US 380 EXISTING

NOT TO SCALE

NOT INTENDED FOR CONSTRUCTION,
 BIDDING OR PERMIT PURPOSES
 DHRUVA LAHON, P.E.
 SERIAL NUMBER 102185

EXISTING US 380 AND
 LAKE FOREST DR
 AVERAGE DAILY TRAFFIC

Kimley»Horn
F-928

0135-02-065,
 ETC. SHEET 48 OF 63

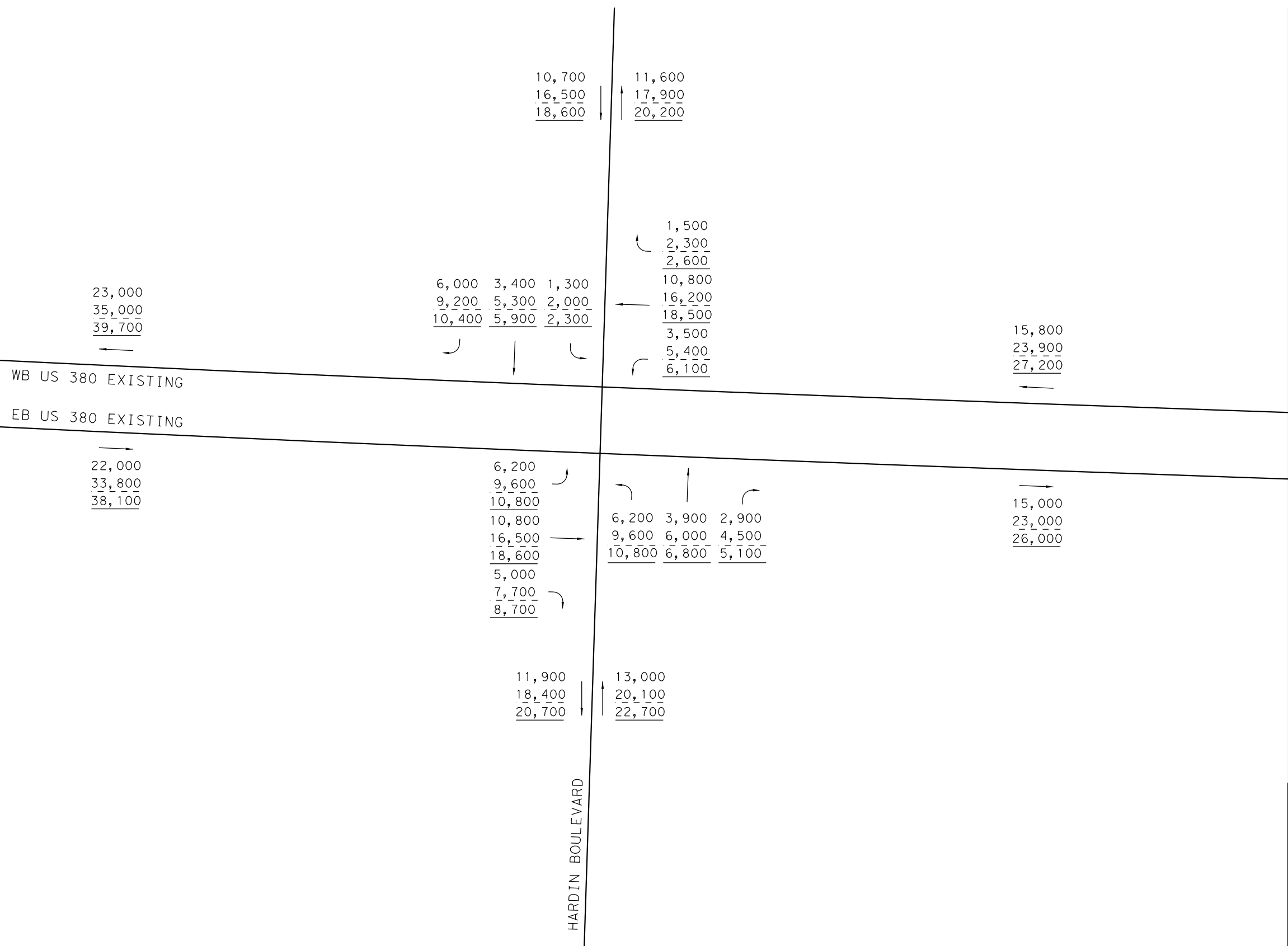
LEGEND

- XXXX- 2030 AVERAGE DAILY TRAFFIC VOLUMES
- XXXX- 2050 AVERAGE DAILY TRAFFIC VOLUMES
- XXXX- 2060 AVERAGE DAILY TRAFFIC VOLUMES



SEE SHEET 48 OF 63

SEE SHEET 50 OF 63



LEGEND

- XXXX- 2030 AVERAGE DAILY TRAFFIC VOLUMES
- XXXX- 2050 AVERAGE DAILY TRAFFIC VOLUMES
- XXXX- 2060 AVERAGE DAILY TRAFFIC VOLUMES

NOT TO SCALE

NOT INTENDED FOR CONSTRUCTION,
 BIDDING OR PERMIT PURPOSES
 DHRUVA LAHON, P.E.
 SERIAL NUMBER 102185

EXISTING US 380 AND HARDIN BLVD AVERAGE DAILY TRAFFIC

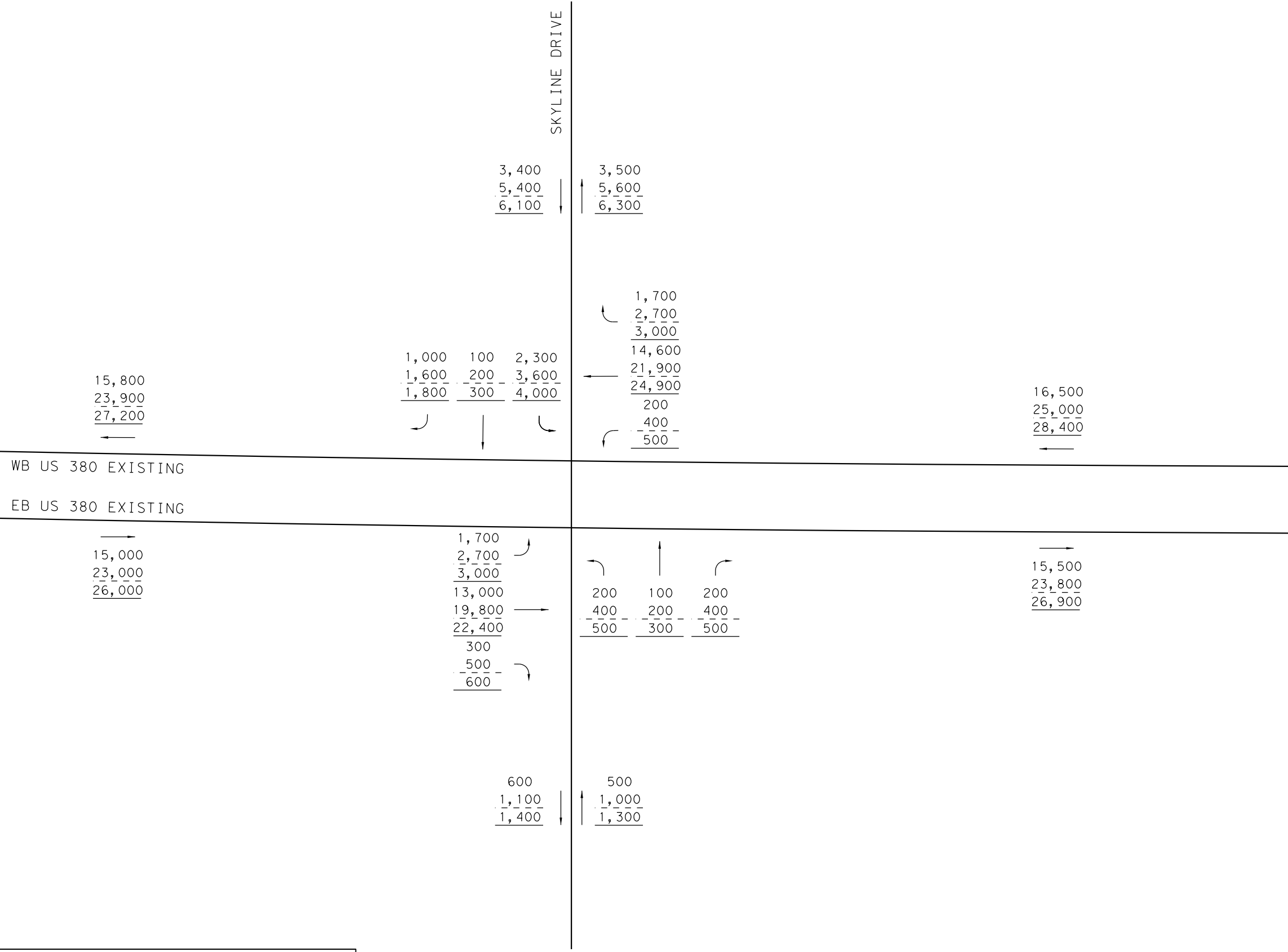


DATE: 7/13/2021
 FILE: US380_BLUE_TRF_49.dgn



SEE SHEET 49 OF 63

SEE SHEET 51 OF 63



WB US 380 EXISTING
 EB US 380 EXISTING

NOT TO SCALE

NOT INTENDED FOR CONSTRUCTION,
 BIDDING OR PERMIT PURPOSES
 DHRUVA LAHON, P.E.
 SERIAL NUMBER 102185

EXISTING US 380 AND
 SKYLINE DR
 AVERAGE DAILY TRAFFIC

Kimley»Horn
F-928

0135-02-065,
 ETC. SHEET 50 OF 63

LEGEND

- XXXX- 2030 AVERAGE DAILY TRAFFIC VOLUMES
- XXXX- 2050 AVERAGE DAILY TRAFFIC VOLUMES
- XXXX- 2060 AVERAGE DAILY TRAFFIC VOLUMES

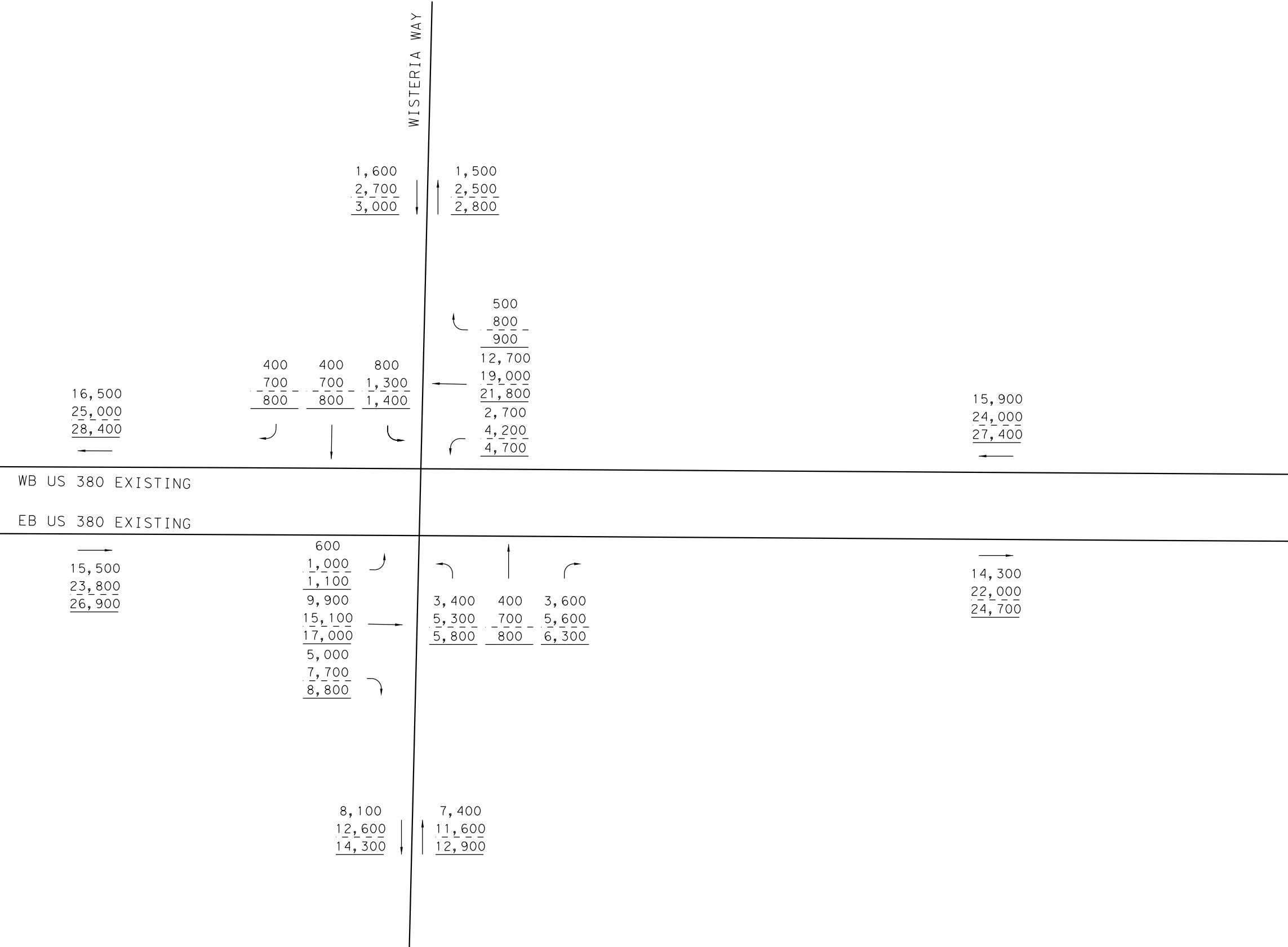
DATE: 7/13/2021
 FILE: US380_BLUE_TRF_50.dgn



SEE SHEET 50 OF 63

SEE SHEET 52 OF 63

WISTERIA WAY



WB US 380 EXISTING
EB US 380 EXISTING

NOT TO SCALE

NOT INTENDED FOR CONSTRUCTION,
BIDDING OR PERMIT PURPOSES
DHURVA LAHON, P.E.
SERIAL NUMBER 102185

EXISTING US 380 AND
WISTERIA WAY
AVERAGE DAILY TRAFFIC



0135-02-065, ETC. SHEET 51 OF 63

LEGEND

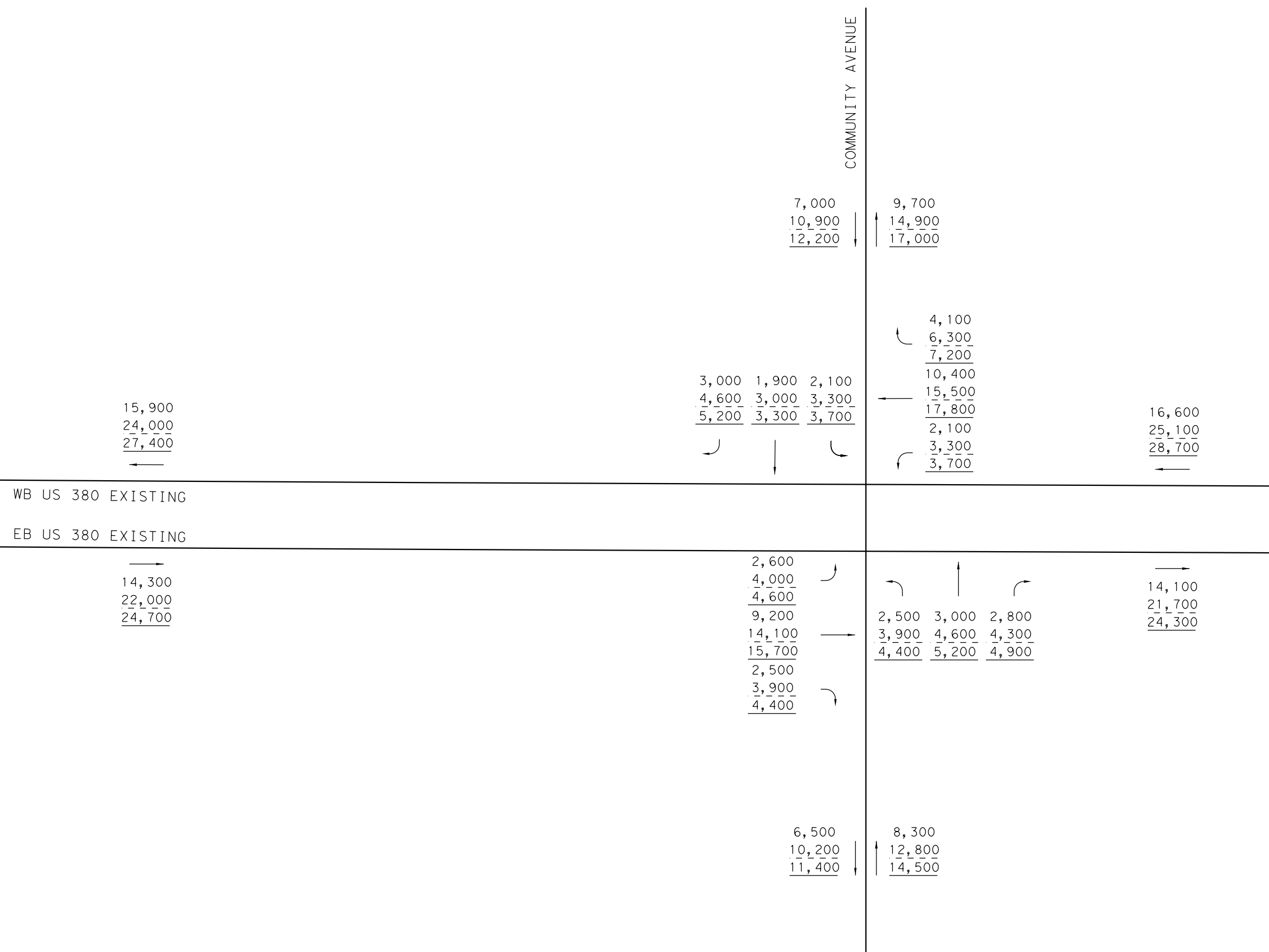
- XXXX- 2030 AVERAGE DAILY TRAFFIC VOLUMES
- XXXX- 2050 AVERAGE DAILY TRAFFIC VOLUMES
- XXXX- 2060 AVERAGE DAILY TRAFFIC VOLUMES

DATE: 7/13/2021
FILE: US380_BLUE_TRF_51.dgn



SEE SHEET 51 OF 63

SEE SHEET 53 OF 63



NOT TO SCALE

NOT INTENDED FOR CONSTRUCTION,
BIDDING OR PERMIT PURPOSES
DHURVA LAHON, P.E.
SERIAL NUMBER 102185

EXISTING US 380 AND
COMMUNITY AVE
AVERAGE DAILY TRAFFIC

Kimley»Horn
F-928

0135-02-065,
ETC. SHEET 52 OF 63

LEGEND

- XXXX- 2030 AVERAGE DAILY TRAFFIC VOLUMES
- XXXX- 2050 AVERAGE DAILY TRAFFIC VOLUMES
- XXXX- 2060 AVERAGE DAILY TRAFFIC VOLUMES

DATE: 7/13/2021
FILE: US380_BLUE_TRF_52.dgn



SEE SHEET 52 OF 63

SEE SHEET 54 OF 63

WB US 380 EXISTING
EB US 380 EXISTING

TOWNE CROSSING

16,600
25,100
28,700

2,600 400 1,500
4,000 700 2,300
4,600 800 2,600

4,500
7,000
8,000

3,000
4,800
5,400

200
400
500
11,700
17,500
20,100
1,400
2,200
2,500

13,300
20,100
23,100

14,100
21,700
24,300

2,000
3,100
3,500
10,900
16,700
18,700
1,200
1,900
2,100

2,300 800 800
3,600 1,300 1,300
4,000 1,400 1,400

13,200
20,300
22,700

3,000
4,800
5,400

3,900
6,200
6,800

NOT TO SCALE

NOT INTENDED FOR CONSTRUCTION,
BIDDING OR PERMIT PURPOSES
DHURVA LAHON, P.E.
SERIAL NUMBER 102185

EXISTING US 380 AND
TOWNE CROSSING
AVERAGE DAILY TRAFFIC

Kimley»Horn
F-928

0135-02-065,
ETC. SHEET 53 OF 63

LEGEND

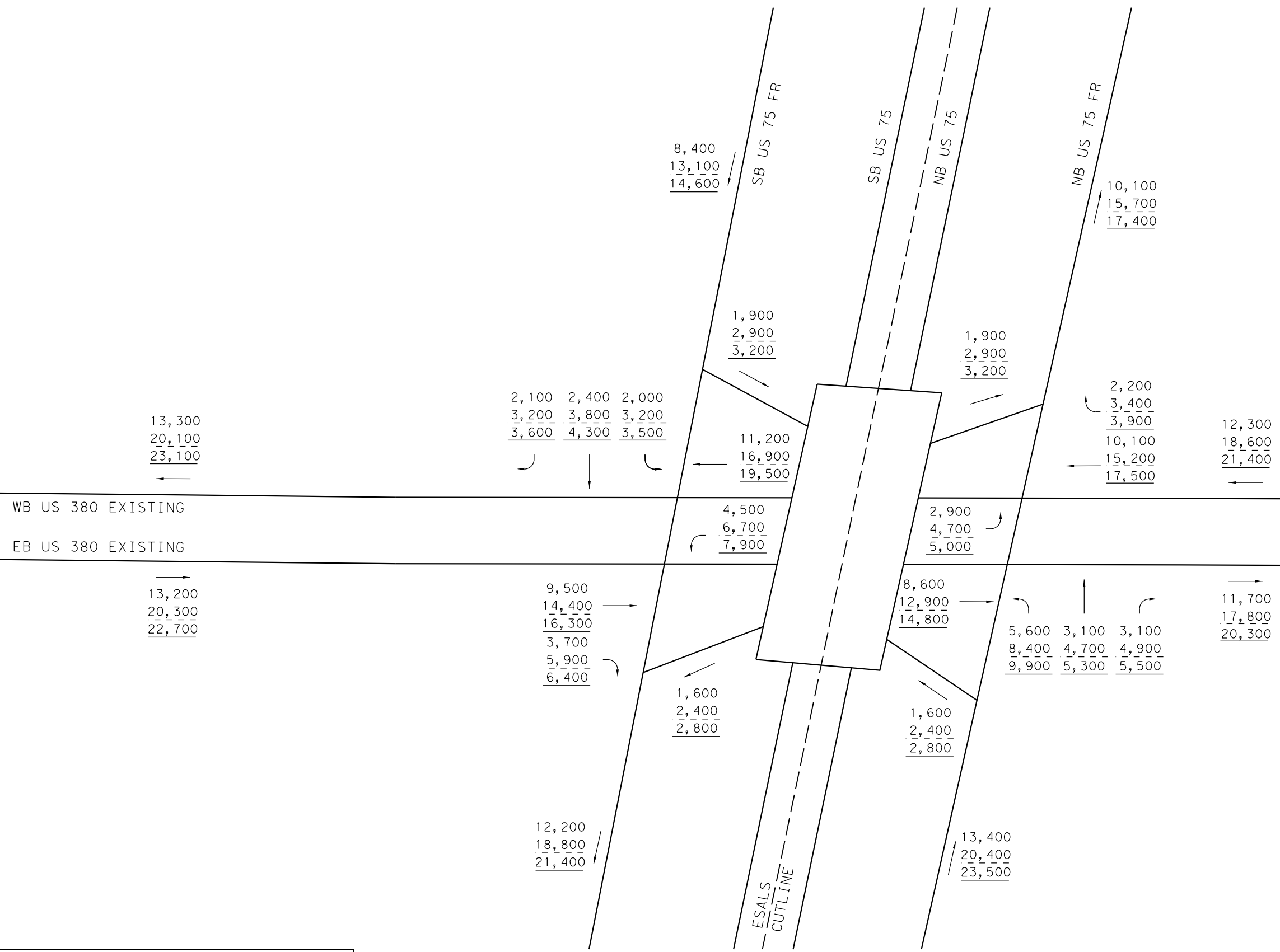
- XXXX- 2030 AVERAGE DAILY TRAFFIC VOLUMES
- XXXX- 2050 AVERAGE DAILY TRAFFIC VOLUMES
- XXXX- 2060 AVERAGE DAILY TRAFFIC VOLUMES

DATE: 7/13/2021
FILE: US380_BLUE_TRF_53.dgn



SEE SHEET 53 OF 63

SEE SHEET 55 OF 63



LEGEND

- XXXX- 2030 AVERAGE DAILY TRAFFIC VOLUMES
- XXX- 2050 AVERAGE DAILY TRAFFIC VOLUMES
- XX- 2060 AVERAGE DAILY TRAFFIC VOLUMES

NOT TO SCALE

NOT INTENDED FOR CONSTRUCTION,
 BIDDING OR PERMIT PURPOSES
 DHRUVA LAHON, P.E.
 SERIAL NUMBER 102185

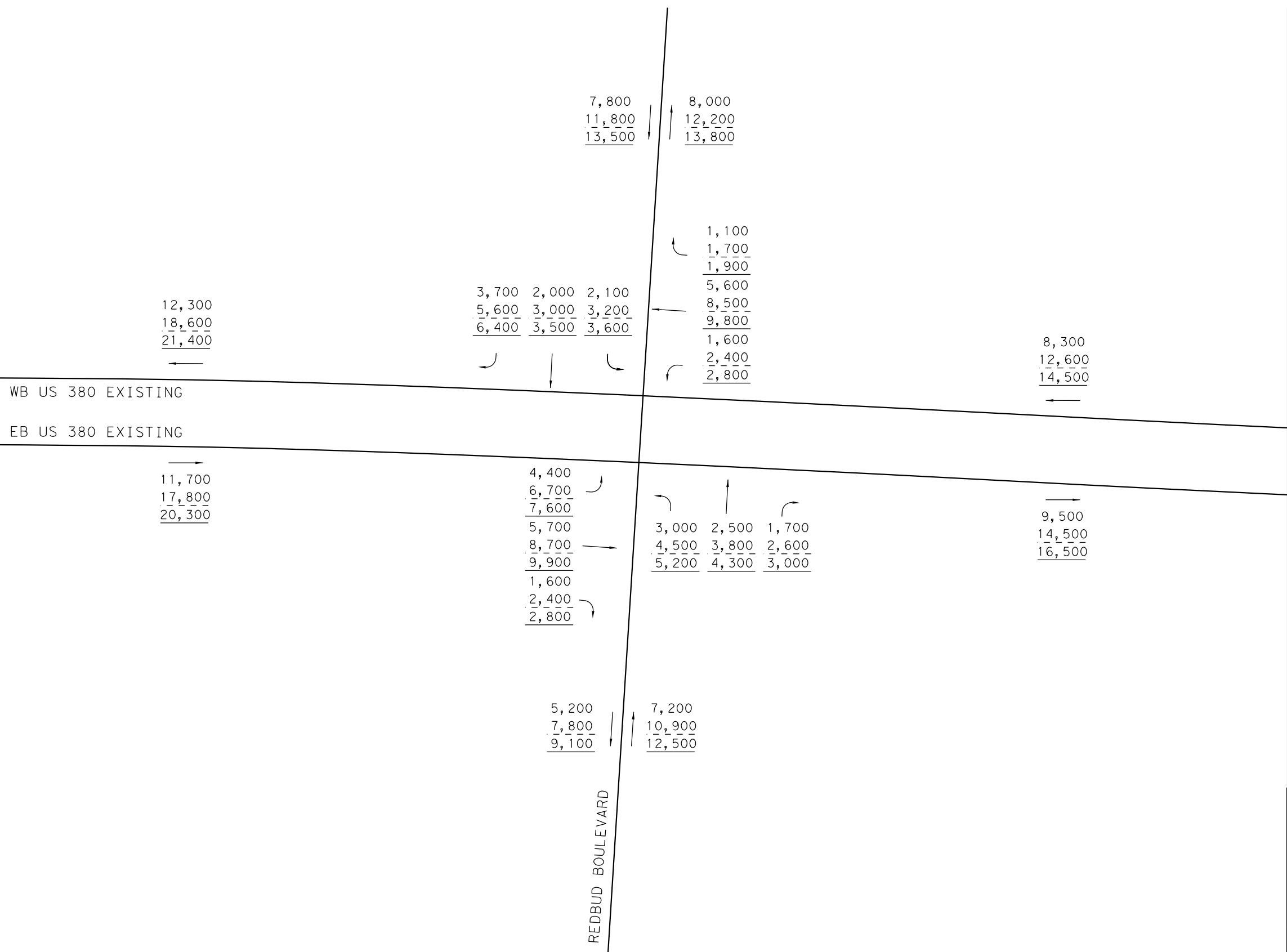
EXISTING US 380 AND US 75 AVERAGE DAILY TRAFFIC





SEE SHEET 54 OF 63

SEE SHEET 56 OF 63



WB US 380 EXISTING
 EB US 380 EXISTING

REDBUD BOULEVARD

NOT TO SCALE

NOT INTENDED FOR CONSTRUCTION,
 BIDDING OR PERMIT PURPOSES
 DHRUVA LAHON, P.E.
 SERIAL NUMBER 102185

EXISTING US 380 AND
 REDBUD BLVD
 AVERAGE DAILY TRAFFIC

Kimley»Horn
F-928

0135-02-065,
 ETC. SHEET 55 OF 63

LEGEND

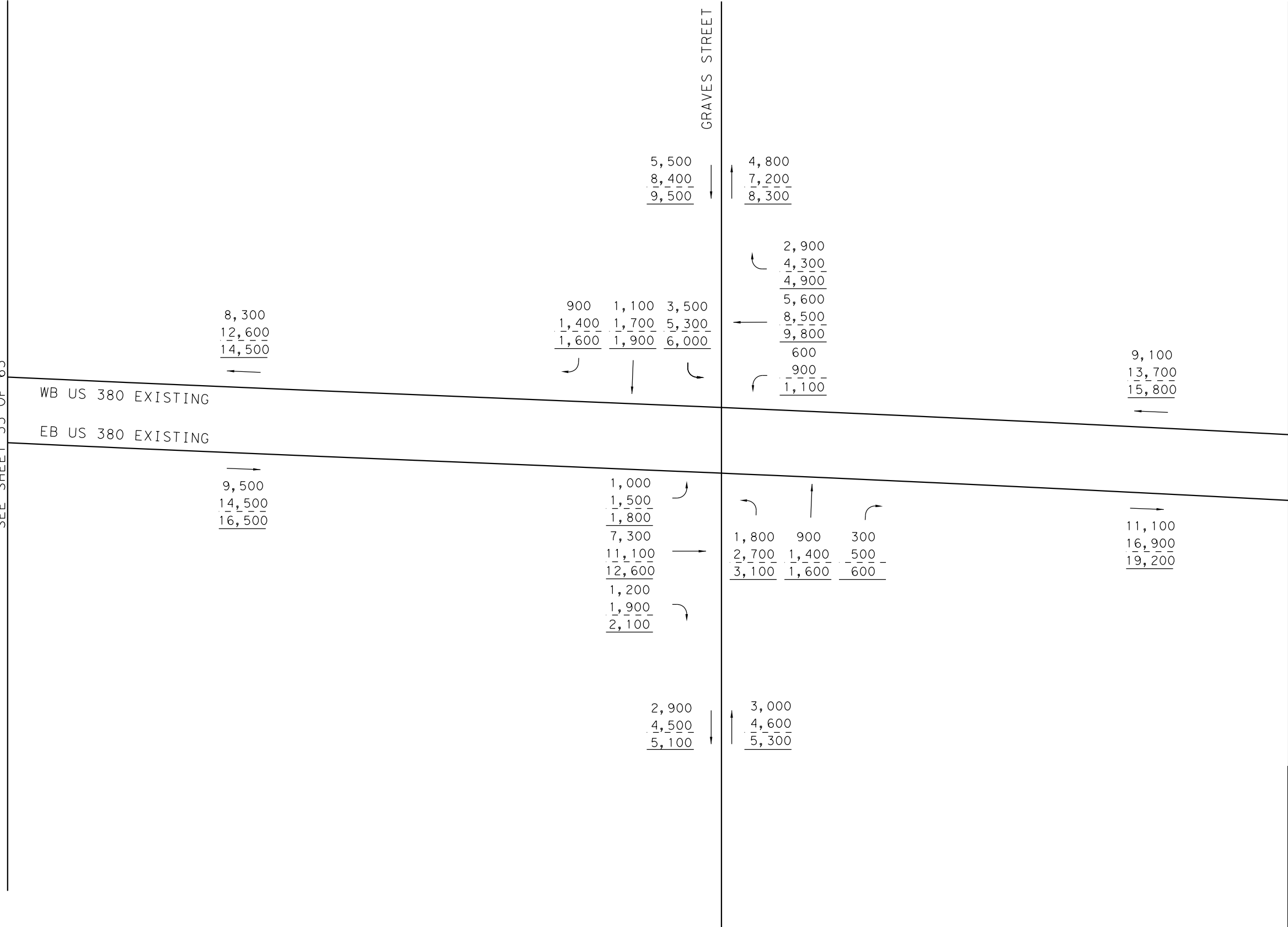
- XXXX- 2030 AVERAGE DAILY TRAFFIC VOLUMES
- XXXX- 2050 AVERAGE DAILY TRAFFIC VOLUMES
- XXXX- 2060 AVERAGE DAILY TRAFFIC VOLUMES

DATE: 7/13/2021
 FILE: US380_BLUE_TRF_55.dgn



SEE SHEET 55 OF 63

SEE SHEET 57 OF 63



WB US 380 EXISTING

EB US 380 EXISTING

GRAVES STREET

NOT TO SCALE

NOT INTENDED FOR CONSTRUCTION,
 BIDDING OR PERMIT PURPOSES
 DHRUVA LAHON, P.E.
 SERIAL NUMBER 102185

EXISTING US 380 AND
 GRAVES ST
 AVERAGE DAILY TRAFFIC

Kimley»Horn
F-928

0135-02-065,
 ETC. SHEET 56 OF 63

LEGEND

- XXXX- 2030 AVERAGE DAILY TRAFFIC VOLUMES
- XXXX- 2050 AVERAGE DAILY TRAFFIC VOLUMES
- XXXX- 2060 AVERAGE DAILY TRAFFIC VOLUMES

DATE: 7/13/2021
 FILE: US380_BLUE_TRF_56.dgn



SEE SHEET 56 OF 63

SEE SHEET 58 OF 63

WB US 380 EXISTING

EB US 380 EXISTING

WADDILL STREET

9,100
13,700
15,800

200 200 600
300 300 900
400 400 1,100

1,000 600
1,500 900
1,900 1,200

200
300
400
8,200
12,300
14,100
900
1,400
1,600

9,300
14,000
16,100

11,100
16,900
19,200

200
300
400
9,800
14,900
16,900
1,100
1,700
1,900

700 200 1,300
1,100 300 2,000
1,300 400 2,300

11,700
17,800
20,300

2,200 2,200
3,400 3,400
3,900 4,000

NOT TO SCALE

NOT INTENDED FOR CONSTRUCTION,
BIDDING OR PERMIT PURPOSES
DHURVA LAHON, P.E.
SERIAL NUMBER 102185

EXISTING US 380 AND
WADDILL ST
AVERAGE DAILY TRAFFIC

Kimley»Horn
F-928

0135-02-065,
ETC. SHEET 57 OF 63

LEGEND

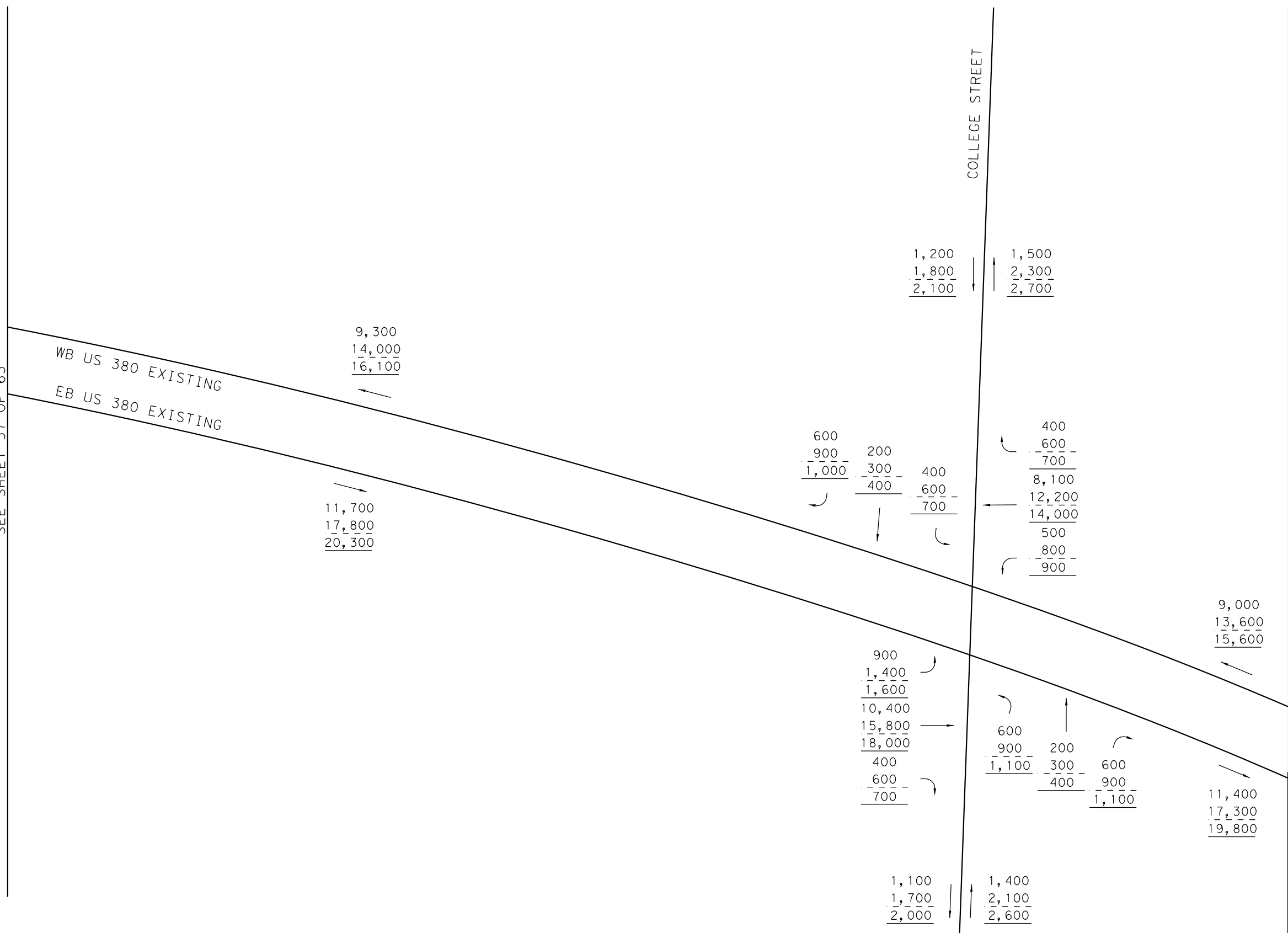
- XXXX- 2030 AVERAGE DAILY TRAFFIC VOLUMES
- XXXX- 2050 AVERAGE DAILY TRAFFIC VOLUMES
- XXXX- 2060 AVERAGE DAILY TRAFFIC VOLUMES

DATE: 7/13/2021
FILE: US380_BLUE_TRF_57.dgn



SEE SHEET 57 OF 63

SEE SHEET 59 OF 63



NOT TO SCALE

NOT INTENDED FOR CONSTRUCTION,
 BIDDING OR PERMIT PURPOSES
 DHRUVA LAHON, P.E.
 SERIAL NUMBER 102185

EXISTING US 380 AND
 COLLEGE ST
 AVERAGE DAILY TRAFFIC

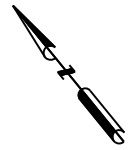
Kimley»Horn
F-928

0135-02-065,
 ETC. SHEET 58 OF 63

LEGEND

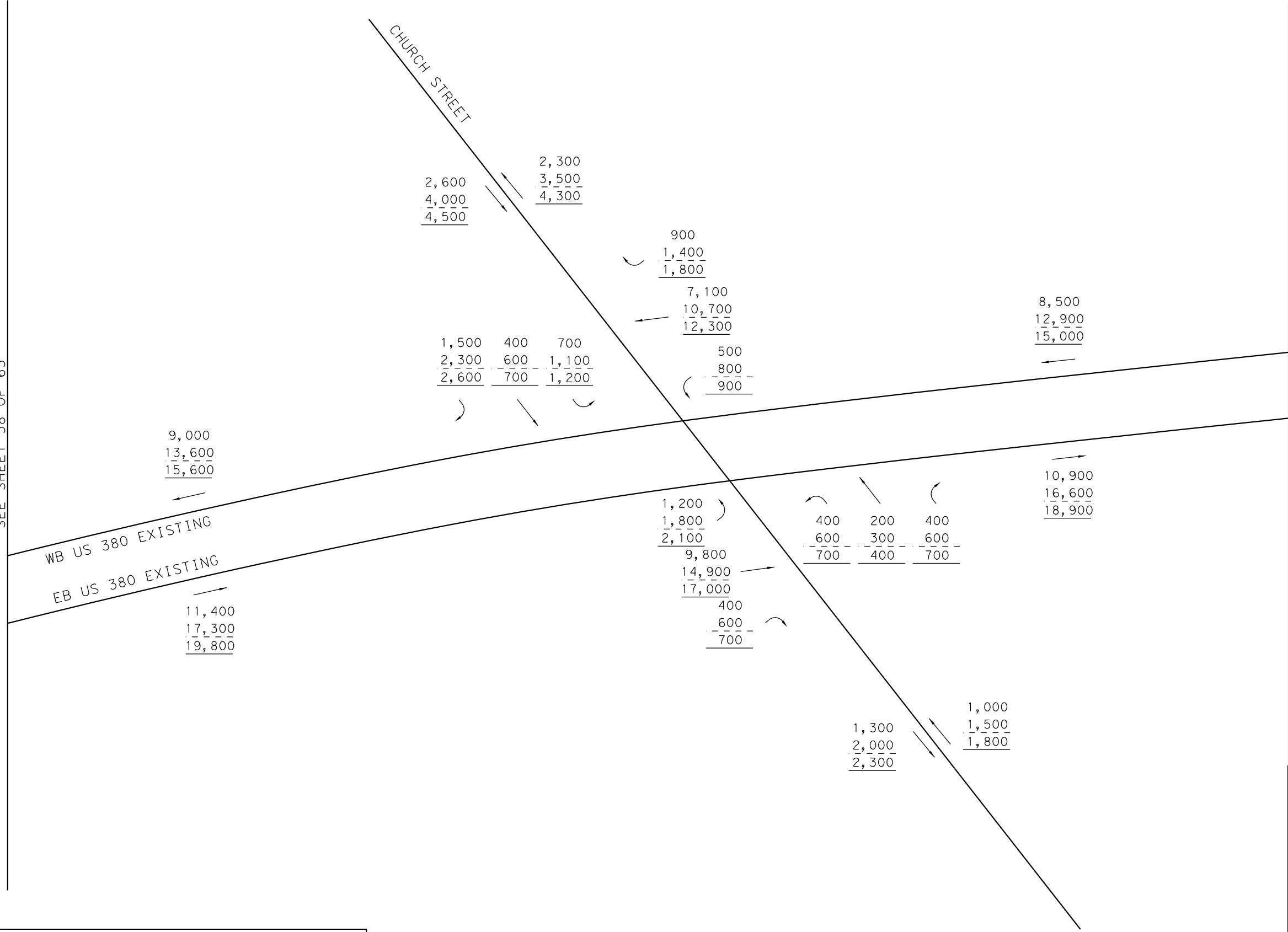
- XXXX- 2030 AVERAGE DAILY TRAFFIC VOLUMES
- XXXX- 2050 AVERAGE DAILY TRAFFIC VOLUMES
- XXXX- 2060 AVERAGE DAILY TRAFFIC VOLUMES

DATE: 7/13/2021
 FILE: US380_BLUE_TRF_58.dgn



SEE SHEET 58 OF 63

SEE SHEET 60 OF 63



LEGEND

XXXX	-	2030	AVERAGE	DAILY	TRAFFIC	VOLUMES
-XXXX	-	2050	AVERAGE	DAILY	TRAFFIC	VOLUMES
XXXX	-	2060	AVERAGE	DAILY	TRAFFIC	VOLUMES

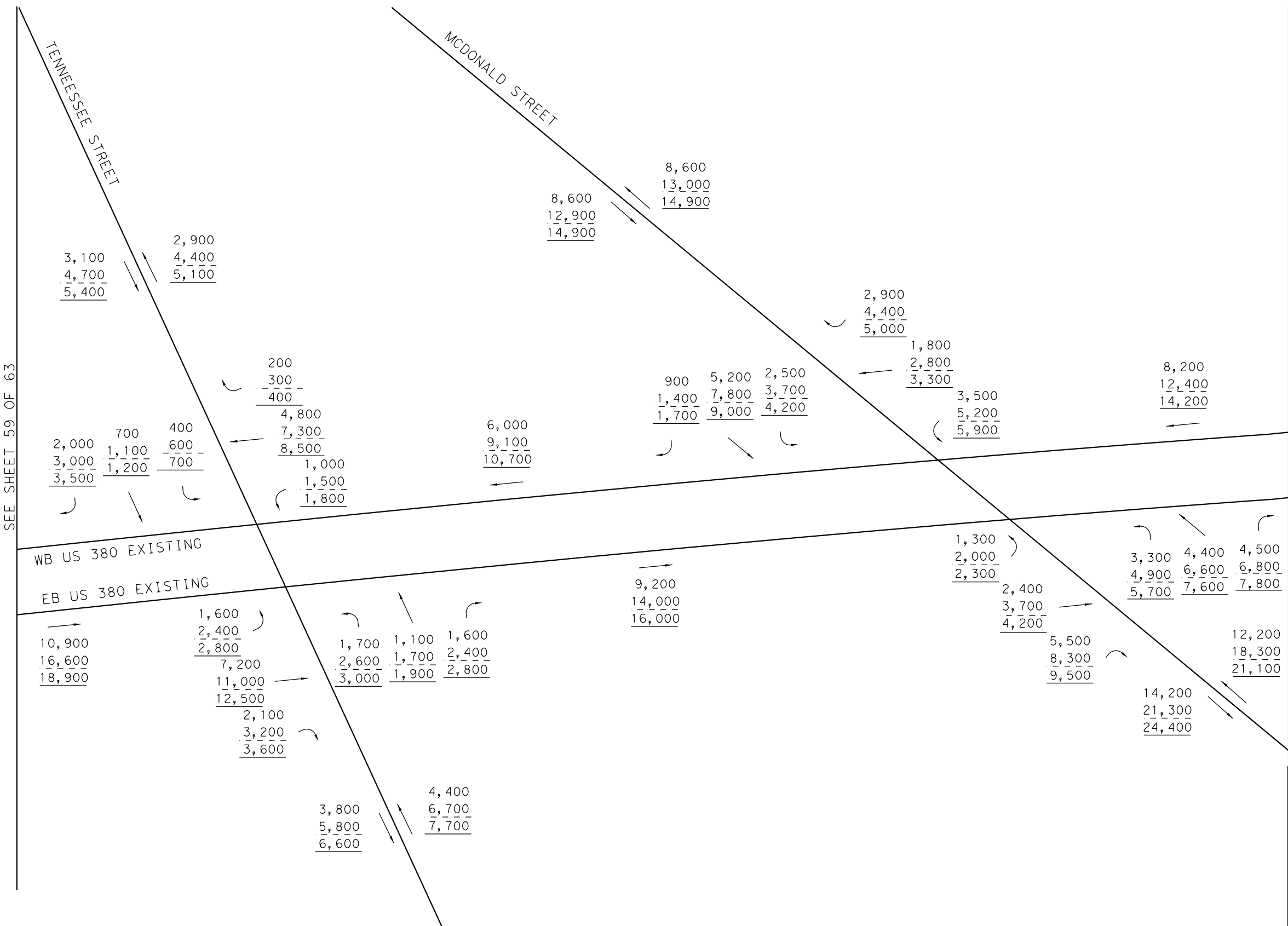
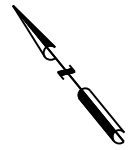
NOT TO SCALE

NOT INTENDED FOR CONSTRUCTION,
 BIDDING OR PERMIT PURPOSES
 DHRUVA LAHON, P.E.
 SERIAL NUMBER 102185

EXISTING US 380 AND CHURCH ST AVERAGE DAILY TRAFFIC



DATE: 7/13/2021
FILE: US380_BLUE_TRF_59.dgn



SEE SHEET 59 OF 63

SEE SHEET 61 OF 63

NOT TO SCALE

NOT INTENDED FOR CONSTRUCTION,
 BIDDING OR PERMIT PURPOSES
 DHRUVA LAHON, P.E.
 SERIAL NUMBER 102185

EXISTING US 380 AND
 MCDONALD ST/ SH 5
 AVERAGE DAILY TRAFFIC

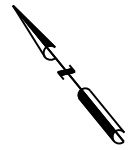
Kimley»Horn
F-928

0135-02-065,
 ETC. SHEET 60 OF 63

LEGEND

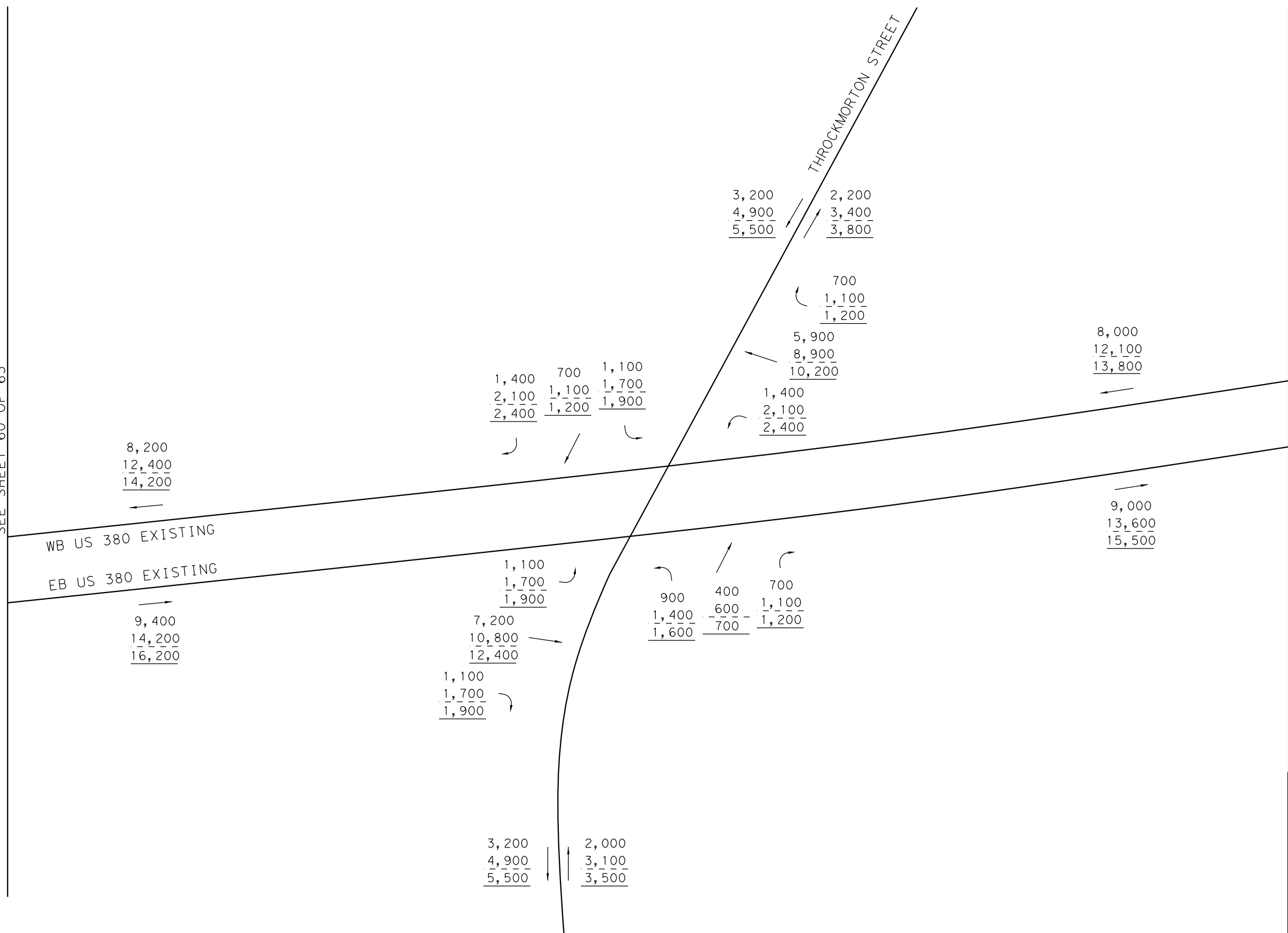
- XXXX- 2030 AVERAGE DAILY TRAFFIC VOLUMES
- XXXX- 2050 AVERAGE DAILY TRAFFIC VOLUMES
- XXXX- 2060 AVERAGE DAILY TRAFFIC VOLUMES

DATE: 7/13/2021
 FILE: US380_BLUE_TRF_60.dgn



SEE SHEET 60 OF 63

SEE SHEET 62 OF 63



LEGEND

- XXXX- 2030 AVERAGE DAILY TRAFFIC VOLUMES
- XXXX- 2050 AVERAGE DAILY TRAFFIC VOLUMES
- XXXX- 2060 AVERAGE DAILY TRAFFIC VOLUMES

NOT TO SCALE

NOT INTENDED FOR CONSTRUCTION,
 BIDDING OR PERMIT PURPOSES
 DHRUVA LAHON, P.E.
 SERIAL NUMBER 102185

EXISTING US 380 AND THROCKMORTON ST AVERAGE DAILY TRAFFIC

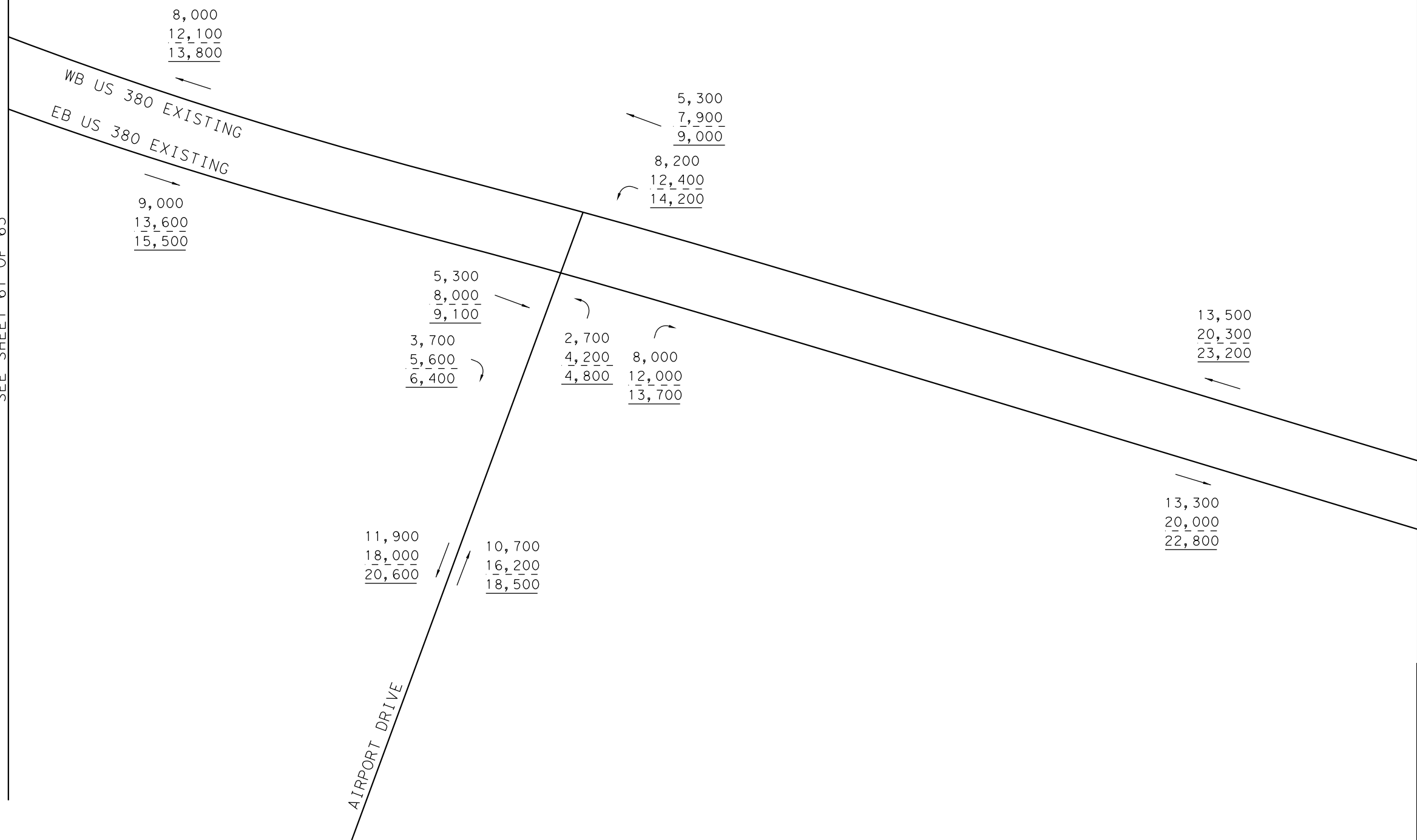


DATE: 7/13/2021
 FILE: US380_BLUE_TRF_61.dgn



SEE SHEET 61 OF 63

SEE SHEET 63 OF 63



NOT TO SCALE

NOT INTENDED FOR CONSTRUCTION,
 BIDDING OR PERMIT PURPOSES
 DHRUVA LAHON, P.E.
 SERIAL NUMBER 102185

EXISTING US 380 AND
 AIRPORT DR
 AVERAGE DAILY TRAFFIC



0135-02-065,
 ETC. SHEET 62 OF 63

LEGEND

- XXXX- 2030 AVERAGE DAILY TRAFFIC VOLUMES
- XXXX- 2050 AVERAGE DAILY TRAFFIC VOLUMES
- XXXX- 2060 AVERAGE DAILY TRAFFIC VOLUMES

DATE: 7/13/2021
 FILE: US380_BLUE_TRF_62.dgn



SEE SHEET 45 OF 63

13,500		13,300
<u>20,300</u>	↙ ↘	<u>20,000</u>
<u>23,200</u>		<u>22,800</u>

SEE SHEET 62 OF 63

13,500
<u>20,300</u>
<u>23,200</u>

↙
WB US 380 EXISTING
↘
EB US 380 EXISTING

13,300
<u>20,000</u>
<u>22,800</u>

NOT TO SCALE

NOT INTENDED FOR CONSTRUCTION,
BIDDING OR PERMIT PURPOSES
DHURVA LAHON, P.E.
SERIAL NUMBER 102185

EXISTING US 380 AND
NEW HOPE ROAD/ FM 1827
AVERAGE DAILY TRAFFIC

Kimley»Horn
F-928

0135-02-065,
ETC. SHEET 63 OF 63

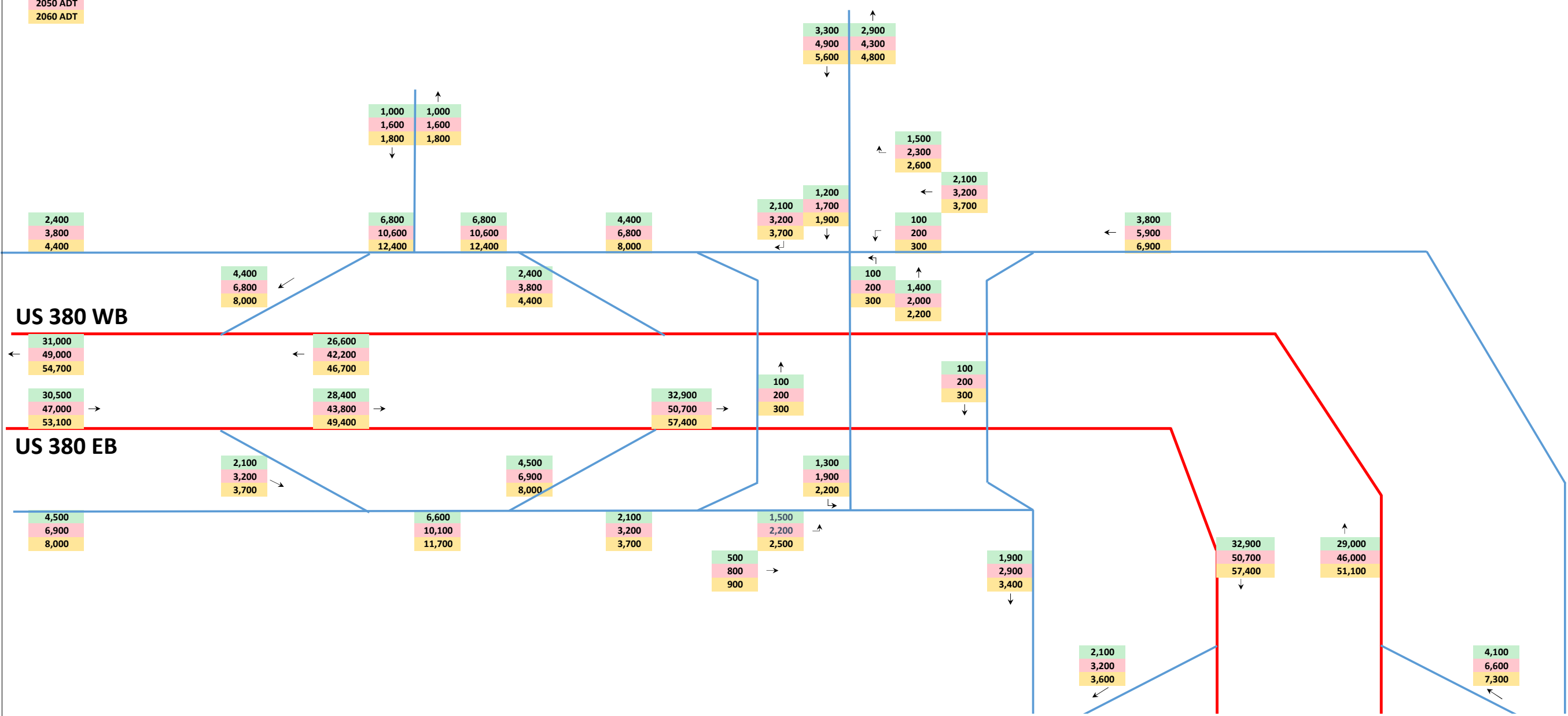
LEGEND

- XXXX- 2030 AVERAGE DAILY TRAFFIC VOLUMES
- XXXX- 2050 AVERAGE DAILY TRAFFIC VOLUMES
- XXXX- 2060 AVERAGE DAILY TRAFFIC VOLUMES

DATE: 7/13/2021
FILE: US380_BLUE_TRF_63.dgn

2030 ADT
2050 ADT
2060 ADT

CR 338



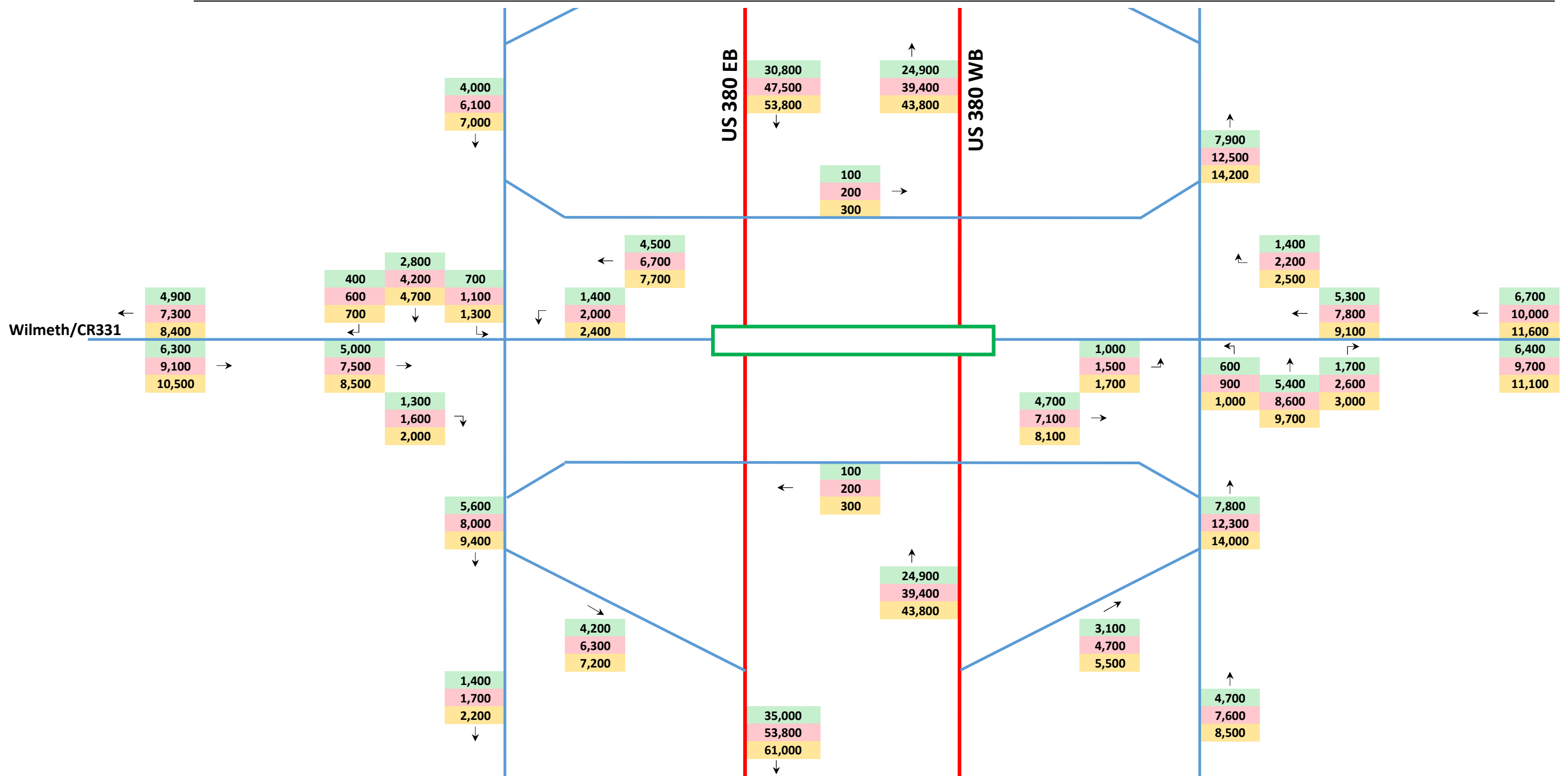
MATCHLINE SEE SHEET 2

LEGEND

- 2030 AVERAGE DAILY TRAFFIC VOLUMES
- 2050 AVERAGE DAILY TRAFFIC VOLUMES
- 2060 AVERAGE DAILY TRAFFIC VOLUMES

US 380 SEGMENT C AVERAGE DAILY VOLUMES

MATCHLINE SEE SHEET 1



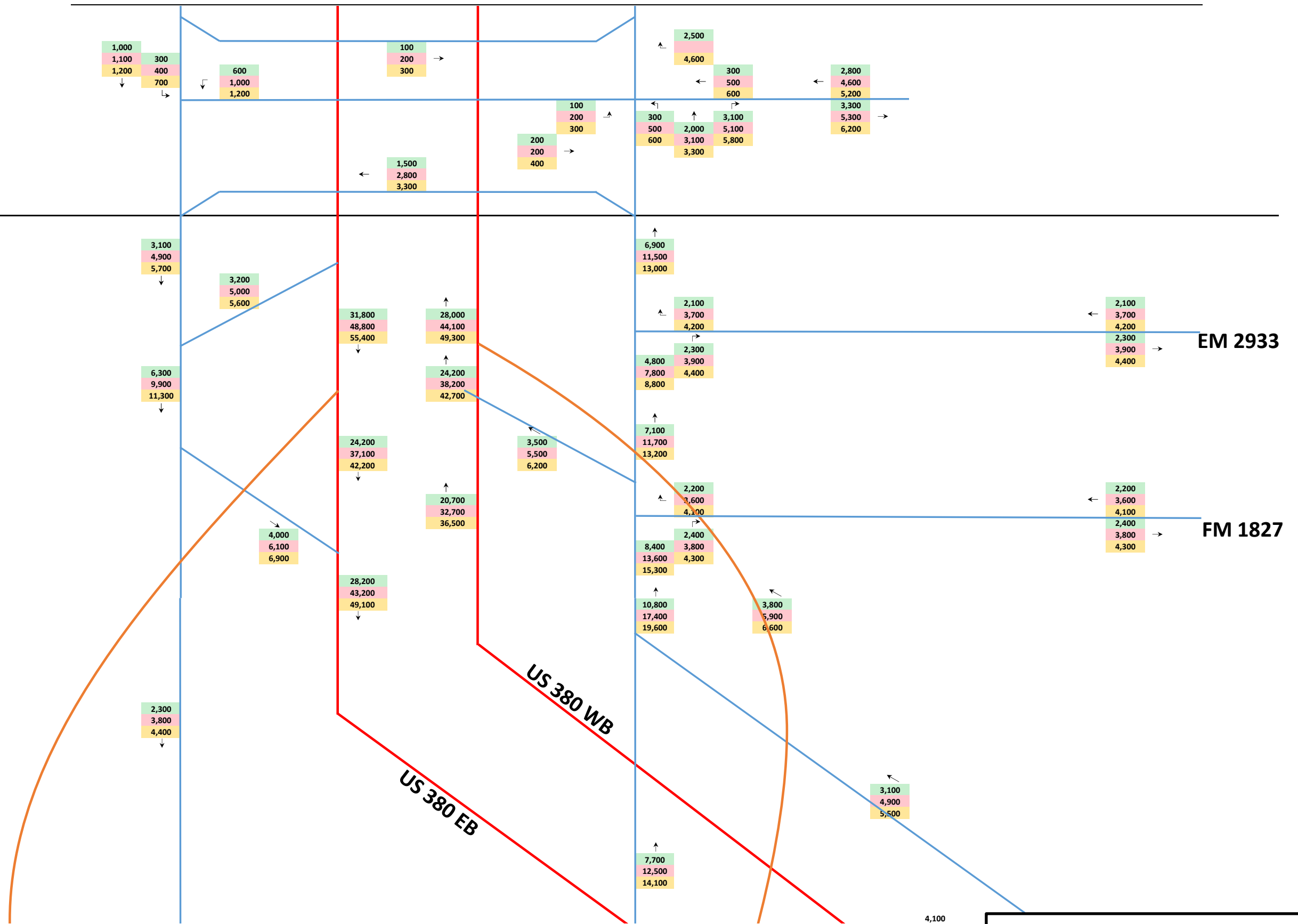
MATCHLINE SEE SHEET 3

LEGEND

- 2030 AVERAGE DAILY TRAFFIC VOLUMES
- 2050 AVERAGE DAILY TRAFFIC VOLUMES
- 2060 AVERAGE DAILY TRAFFIC VOLUMES

US 380 SEGMENT C AVERAGE DAILY VOLUMES

MATCHLINE SEE SHEET 2



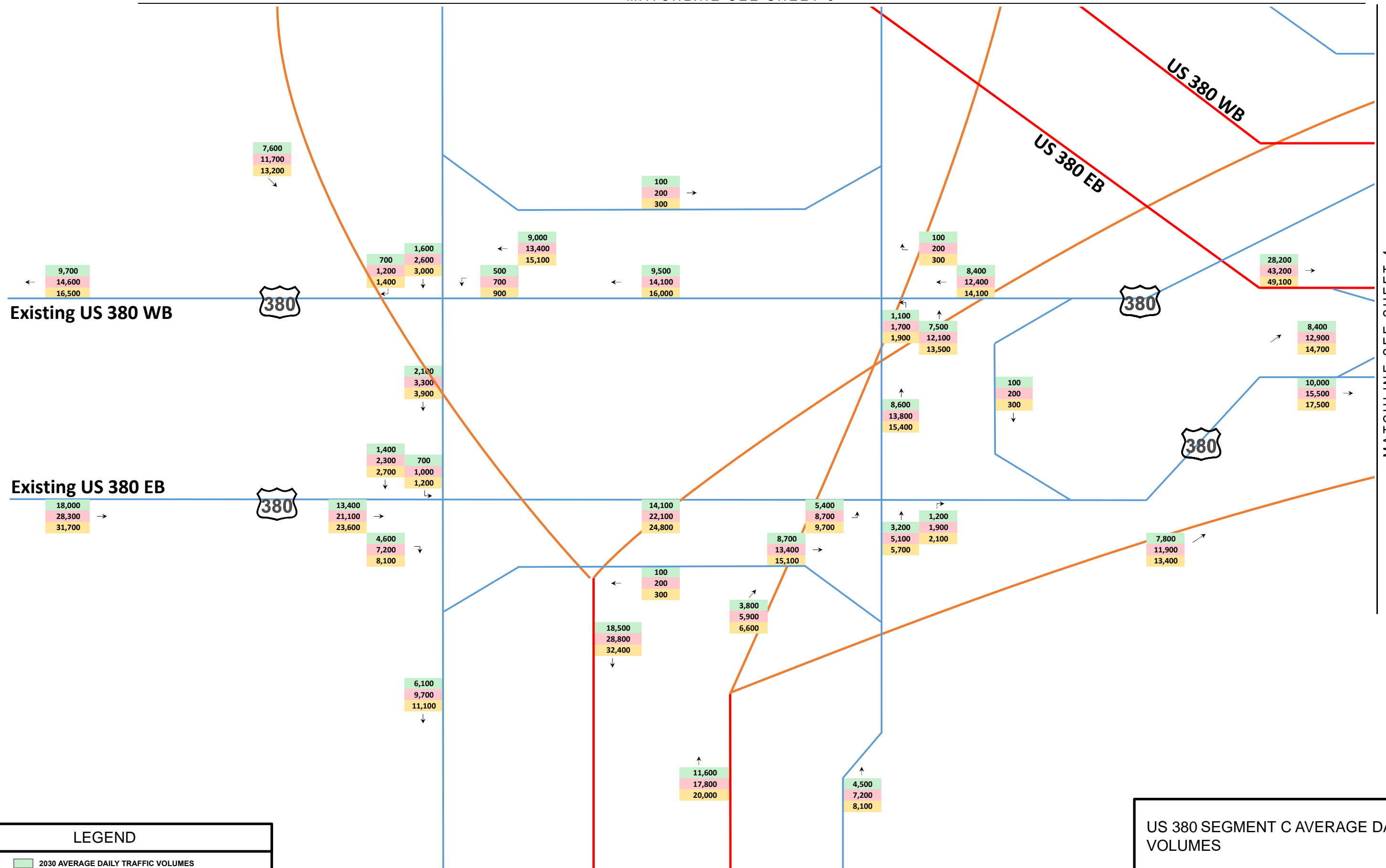
MATCHLINE SEE SHEET 4

LEGEND

- 2030 AVERAGE DAILY TRAFFIC VOLUMES
- 2050 AVERAGE DAILY TRAFFIC VOLUMES
- 2060 AVERAGE DAILY TRAFFIC VOLUMES

US 380 SEGMENT C AVERAGE DAILY VOLUMES

MATCHLINE SEE SHEET 3



MATCHLINE SEE SHEET 4

LEGEND

- 2030 AVERAGE DAILY TRAFFIC VOLUMES
- 2050 AVERAGE DAILY TRAFFIC VOLUMES
- 2060 AVERAGE DAILY TRAFFIC VOLUMES

US 380 SEGMENT C AVERAGE DAILY VOLUMES

MATCHLINE SEE SHEET 4

MATCHLINE SEE SHEET 6



LEGEND

- 2030 AVERAGE DAILY TRAFFIC VOLUMES
- 2050 AVERAGE DAILY TRAFFIC VOLUMES
- 2060 AVERAGE DAILY TRAFFIC VOLUMES

US 380 SEGMENT C AVERAGE DAILY VOLUMES	
	SHEET 5 OF 6

MATCHLINE SEE SHEET 5

←	14,600
	22,700
	25,600

US 380 WBFR

←	5,100
	8,300
	9,300

↙	9,500
	14,400
	16,300

↙	4,000
	6,300
	7,000

US 380 WB

←	27,600
	43,500
	48,700

←	37,100
	57,900
	65,000

←	41,100
	64,200
	72,000

KH US 380 Blue Volume

KH US 380 Blue Volume

→	38,700
	59,400
	67,300

→	36,200
	55,600
	63,000

US 380 EB

↘	7,800
	11,900
	13,400

↘	2,500
	3,800
	4,300

US 380 EBFR

→	7,300
	11,200
	12,700

→	9,800
	15,000
	17,000

LEGEND

- 2030 AVERAGE DAILY TRAFFIC VOLUMES
- 2050 AVERAGE DAILY TRAFFIC VOLUMES
- 2060 AVERAGE DAILY TRAFFIC VOLUMES

US 380 SEGMENT C AVERAGE DAILY VOLUMES

Attachment C: Existing Model Validation Study

A validation study was performed in order to verify that the existing model accurately predicts existing traffic noise based on current conditions and to ensure that traffic noise is the main source of noise. Model validation compares field-collected sound level measurements to traffic noise levels calculated in an existing condition model that used field-collected traffic parameters.

Eleven validation sites were selected along the project ROW (see Attachment A). Field measurements were collected on December 14 and 16, 2021 between 8 AM and 5 PM. The weather varied from foggy and overcast to sunny, with light winds less than 12 mph, and no adverse weather conditions obscuring measured levels. During the measurements, traffic was free-flowing and traveling at a relatively constant speed.

A sound level meter was used to measure sound levels in dB(A) Leq. The sound level meter was positioned on a tripod with the microphone facing the roadway and set at a nominal height of five feet. The measurement duration was 30 minutes. The meter was calibrated before measurements were taken and at the end of the day.

Concurrently with each sound level measurement, traffic was counted by personnel in the field to obtain traffic counts by vehicle classification (car, medium truck, and heavy truck). Because the noise modeling software uses a vehicle per hour input, vehicle counts for the 30-minute measurement interval were multiplied by appropriate values to convert counts to the hourly condition. Field data sheets are included at the end of Attachment C.

The FHWA traffic noise modeling software (TNM 2.5) was used to calculate existing traffic noise levels at each validation location, based on the field-observed conditions. The validation model run(s) used the existing roadway parameters, observed hourly traffic counts, and observed speeds.

The traffic noise model validation results are shown in **Table C-1**.

Table C-1. Traffic Noise Levels dB(A) Leq

Validation Site	Field-Measured Level dB(A) Leq	Modeled Level dB(A) Leq	Difference (+/-)	Validated?
ML-3	62.4	59.4	-3.0	Yes
ML-4	69.2	72.2	3.0	Yes
ML-5	59.3	59.9	0.6	Yes
ML-6	70.2	69.2	-1.0	Yes
ML-9	55.2	55.2	0.0	Yes
ML-15	57.3	54.8	-2.5	Yes
ML-17	66.3	63.4	-2.9	Yes

Differences between the measured and model-calculated sound levels were within the +/- 3 dB(A) tolerance allowed by FHWA. Therefore, the existing noise model is considered validated for this project.



SHORT-TERM TRAFFIC NOISE MONITORING LOG SHEET

Reading: ML-3

Project Description: 10226441 - BMCD US380 Spur399 SCH ENV

Noise Source: US 380 – University Drive Traffic Date: Dec. 14, 2021 Personnel: RMB

Equipment	Type	Serial #
Sound Level Meter	Larson Davis	824A2636
Microphone/Preamp	Larson Davis 2541; PRM902	7490
Calibrator	Larson Davis CAL200	2618

SLM SETTINGS (circle one)

FAST

SLOW

WEIGHTING (circle one)

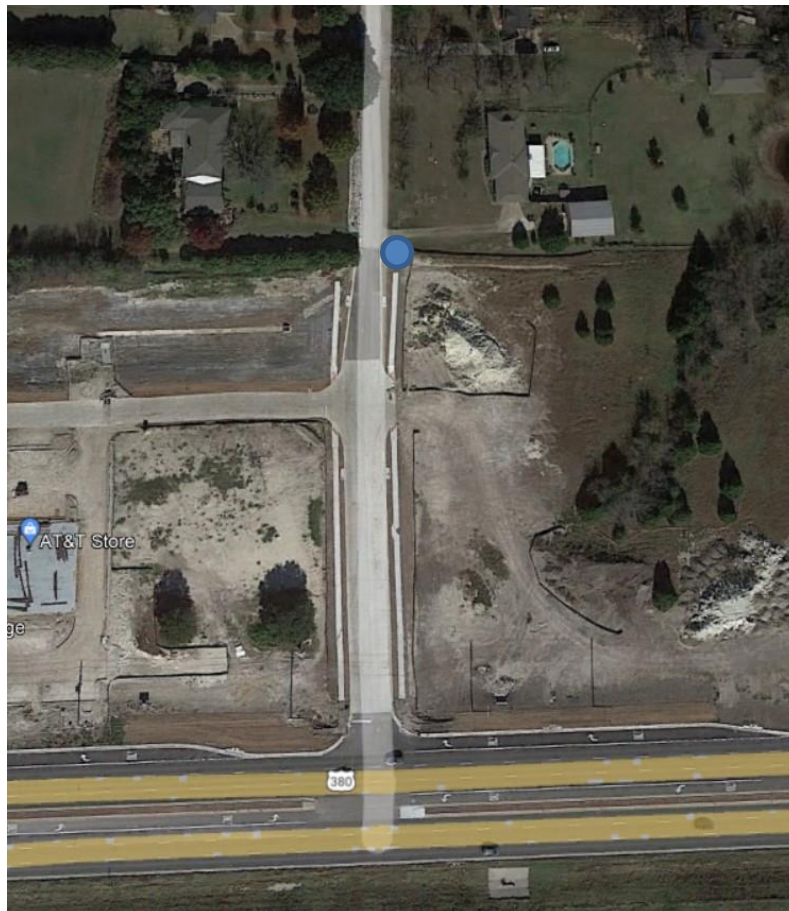
A

Lin.

Location Description: Location ML-3 – US 380 University Drive

SITE SKETCH: Including noise source, receptors, reference distances, North arrow, wind direction arrow, terrain and shielding, roadway profile, and direct lines of sight:

SLM placed on north side of roadway, ~465ft from edge of nearest travel lane of US 380 and 5ft from edge of Hill Top Drive. Acceptable line-of-sight, but slope downward with increasing distance from roadway.





Posted speed 55 mph. Traffic stops at signal light when triggered by traffic turning onto/from Hill Top Drive ; as a result, traffic queues. Some traffic noise due to vehicle pass-bys on Hill Top Drive (30 mph posted), as well as limited construction noise.

Start Time: 9:39:00 AM PM Stop Time: 10:08:00 AM PM Duration: 30 minutes

Wind Speed/Direction: 9 mph S Percentiles: _____

Temperature: 57-64 F Humidity: 96% RH (Partly cloudy)

Calibration results before: _____ 114.2 dBA and after _____ 114.1 dBA

Traffic Count Roadway: US 380 – University Drive EB (Top Row) and WB (Bottom Row)

Autos	Medium Trucks	Heavy Trucks	Buses	Motorcycles
368 per 15 minutes	11 per 15 minutes	15 per 15 minutes	---	----
367 per 15 minutes	6 per 15 minutes	15 per 15 minutes	2 per 15 minutes	----

***Note roadway direction in table**



SHORT-TERM TRAFFIC NOISE MONITORING LOG SHEET

PROJECT: 10226441 - BMCD US380 Spur399 SCH ENV

JOB NO.: 10226441

SITE/READING NO.: File 5

PERSONNEL: RMB

LOCATION/ADDRESS: Location ML-3

DATE: 12/14/2021

#	1 Minute Period Starting	Meas'd Leq (dBA)	v or X	Other Noise Sources	COMMENTS
1	9:39:00	64.4			1 auto Hill Top Drive, red light at end
2	9:40:00	58.2			Vehicle acceleration (green light)
3	9:41:00	60.6			Red light, wind, horn
4	9:42:00	56.7			
5	9:43:00	59.3			
6	9:44:00	58.0			
7	9:45:00	61.6			
8	9:46:00	59.2			1 auto Hill Top Drive
9	9:47:00	58.7			Red light
10	9:48:00	57.0			Green light (acceleration)
11	9:49:00	61.0			
12	9:50:00	67.1			2 auto Hill Top Drive
13	9:51:00	61.1			red light
14	9:52:00	59.9			2 auto Hill Top Drive, green light (acceleration)
15	9:53:00	63.2			1 auto Hill Top Drive
16	9:54:00	63.3			Green light (acceleration)
17	9:55:00	60.7			1 auto Hill Top Drive, red light
18	9:56:00	68.7			1 auto Hill Top Drive, green light (acceleration)
19	9:57:00	60.4			Red light, wind
20	9:58:00	60.1			
21	9:59:00	62.1			1 auto Hill Top Drive, red light
22	10:00:00	66.6			1 auto Hill Top Drive, green light (acceleration)
23	10:01:00	63.9			Red light
24	10:02:00	58.2			Green light (acceleration)
25	10:03:00	60.2			Red light
26	10:04:00	62.4			Green light (acceleration)
27	10:05:00	57.4			Red light, green light (acceleration)
28	10:06:00	62.6			
29	10:07:00	62.9			1 auto Hill Top Drive, bulldozer
30	10:08:00	63.3			1 auto Hill Top Drive, bulldozer

TOTAL Leq = 62.4 dBA

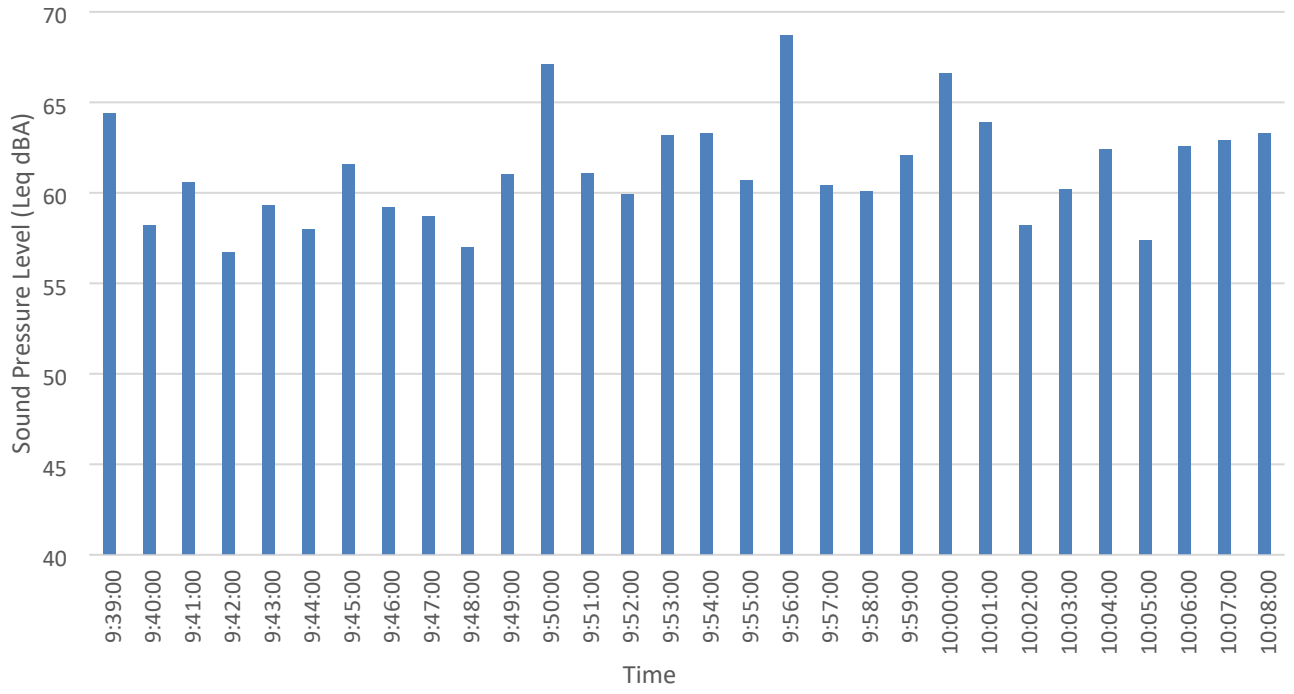
SUBSET Leq =

v = Other sources contributed to Leq X = Exclude period - contaminated by non-characteristic sources

>> ADD SKETCH AND WEATHER CONDITIONS TO REVERSE OR OTHER SHEET <<



Measured Sound Pressure Level ML-3





#	Eastbound				Westbound			
	Auto	Med	Hvy	Motorcycle	Auto	Med	Hvy	Motorcycle
1					32	1	3	
2					17	0	0	
3					25	0	2	
4					19	0	0	
5					31	0	1	
6					10	0	0	
7					47	2	2	
8					10	0	0	
9					40	1	1	
10					10	0	0	
11					27	0	2	
12					9	0	1	
13					34	2	1	
14					12	0	0	
15					44	0	2	
16	40	1	0					
17	15	0	1					
18	26	0	0					
19	23	2	1					
20	21	1	2					
21	14	0	0					
22	39	2	2					
23	9	0	0					
24	27	1	3					
25	17	1	2					
26	20	0	1					
27	24	1	0					
28	27	0	3					
29	20	1	0					
30	46	1	0					



SHORT-TERM TRAFFIC NOISE MONITORING LOG SHEET

Reading: ML-4

Project Description: 10226441 - BMCD US380 Spur399 SCH ENV

Noise Source: US 380 – University Drive Traffic Date: Dec. 14, 2021 Personnel: RMB

Equipment	Type	Serial #
Sound Level Meter	Larson Davis	824A2636
Microphone/Preamp	Larson Davis 2541; PRM902	7490
Calibrator	Larson Davis CAL200	2618

SLM SETTINGS (circle one)

FAST

SLOW

WEIGHTING (circle one)

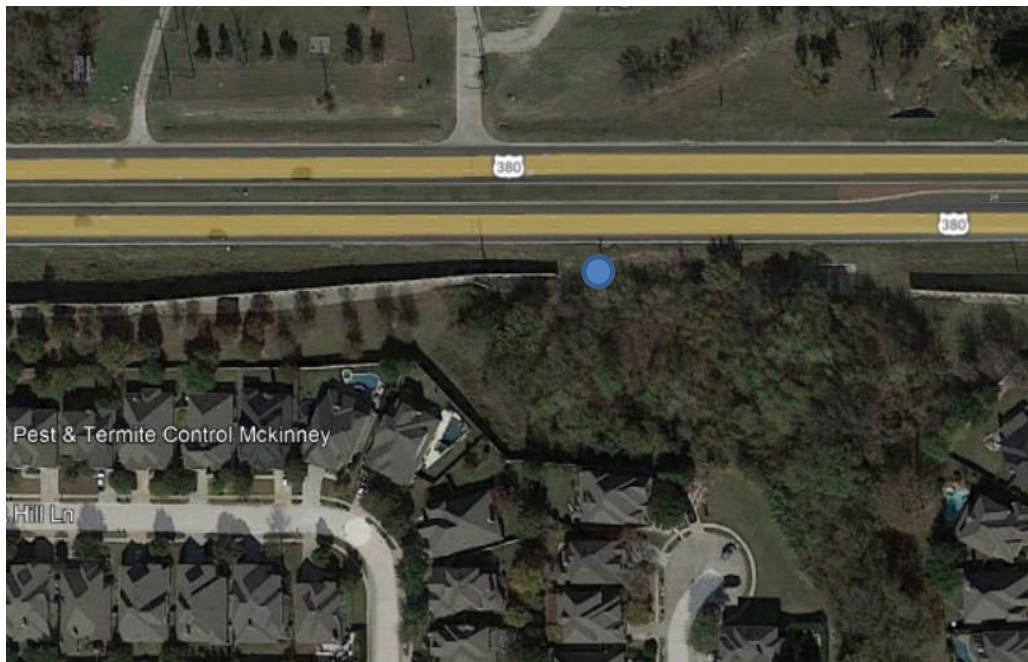
A

Lin.

Location Description: Location ML-4 – US 380 University Drive

SITE SKETCH: Including noise source, receptors, reference distances, North arrow, wind direction arrow, terrain and shielding, roadway profile, and direct lines of sight:

SLM placed on south side of roadway, ~30-35ft from edge of nearest travel lane of US 380 and 10ft from existing highway noise barrier. Microphone about tire height to traffic. Traffic queues for signal light to east. Good line-of-sight, roadway slopes upward towards west.





Start Time:

10:34:32 (AM) PM

Stop Time:

11:03:32 (AM) PM

Duration:

30 minutes

Wind Speed/Direction: 9 mph S

Percentiles: _____

Temperature: 57-64 F

Humidity: 96% RH (Partly cloudy)

Calibration results before: _____ 114.2 dBA and after _____ 114.1 dBA

Traffic Count Roadway: US 380 – University Drive EB (Top Row) and WB (Bottom Row)

Autos	Medium Trucks	Heavy Trucks	Buses	Motorcycles
350 per 15 minutes	11 per 15 minutes	14 per 15 minutes	3 per 15 minutes	1 per 15 minutes
294 per 15 minutes	7 per 15 minutes	21 per 15 minutes	----	1 per 15 minutes

***Note roadway direction in table**



SHORT-TERM TRAFFIC NOISE MONITORING LOG SHEET

PROJECT: 10226441 - BMCD US380 Spur399 SCH ENV

JOB NO.: 10226441

SITE/READING NO.: File 6

PERSONNEL: RMB

LOCATION/ADDRESS: Location ML-4

DATE: 12/14/2021

#	1 Minute Period Starting	Meas'd Leq (dBA)	v or X	Other Noise Sources	COMMENTS
1	10:34:32	69.5			48-51 dBA ambient (no traffic)
2	10:35:32	65.6			
3	10:36:32	68.2			
4	10:37:32	63.1			
5	10:38:32	71.8			
6	10:39:32	69.0			
7	10:40:32	68.4			
8	10:41:32	67.9			
9	10:42:32	71.3			
10	10:43:32	63.8			
11	10:44:32	71.7			
12	10:45:32	62.6			
13	10:46:32	69.2			
14	10:47:32	65.7			
15	10:48:32	77.7			Ambulance (sirens)
16	10:49:32	67.1			
17	10:50:32	68.8			
18	10:51:32	65.8			
19	10:52:32	68.9			
20	10:53:32	66.4			
21	10:54:32	68.7			
22	10:55:32	65.2			Light cycle – traffic movement not significant
23	10:56:32	71.8			
24	10:57:32	65.7			
25	10:58:32	71.0			
26	10:59:32	61.9			
27	11:00:32	68.2			
28	11:01:32	65.0			
29	11:02:32	69.4			
30	11:03:32	66.9			

TOTAL Leq = 69.2 dBA

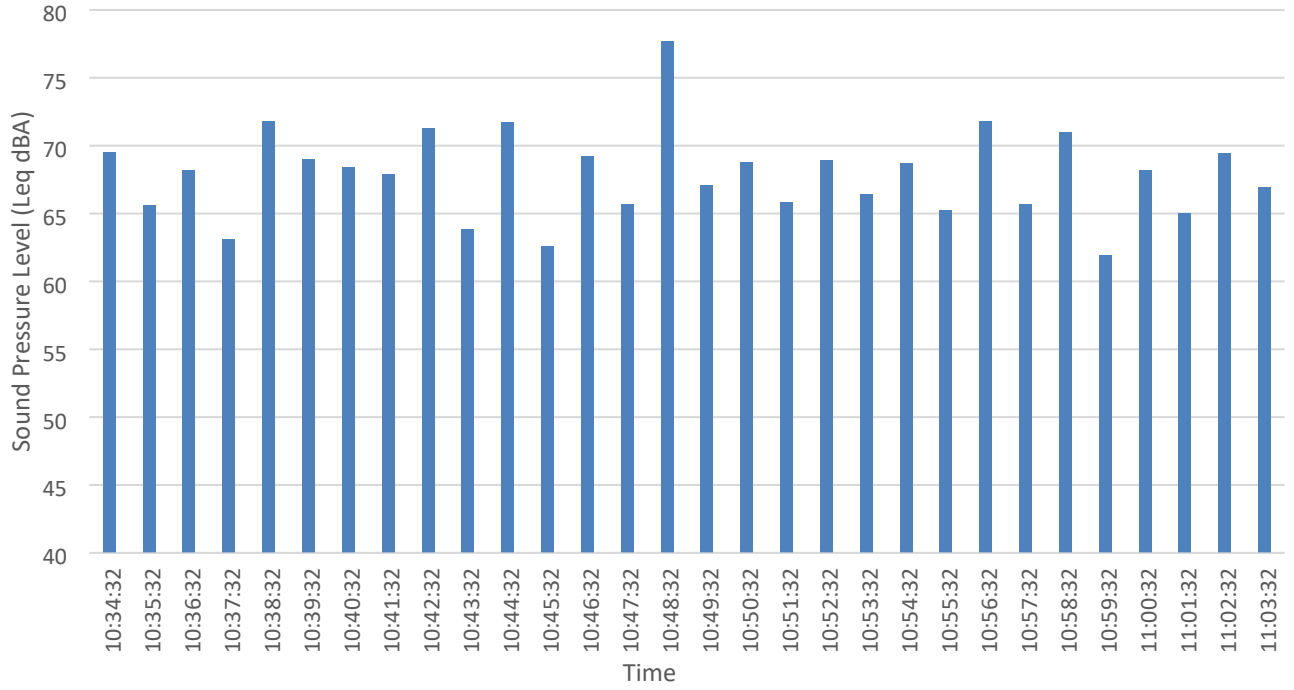
SUBSET Leq =

v = Other sources contributed to Leq X = Exclude period - contaminated by non-characteristic sources

>> ADD SKETCH AND WEATHER CONDITIONS TO REVERSE OR OTHER SHEET <<



Measured Sound Pressure Level ML-4





#	Eastbound				Westbound			
	Auto	Med	Hvy	Motorcycle	Auto	Med	Hvy	Motorcycle
1	24	0	1	0				
2	30	0	0	0				
3	19	2	3	0				
4	29	2	0	0				
5	24	0	2	0				
6	31	2	0	0				
7	7	1	0	0				
8	28	1	0	0				
9	11	0	1	0				
10	10	0	0	0				
11	49	1	1	0				
12	10	0	0	0				
13	36	1	2	0				
14	8	0	0	0				
15	34	1	4	1				
16					20	0	0	0
17					23	2	4	0
18					10	0	0	1
19					6	1	0	0
20					10	0	0	0
21					49	1	3	0
22					3	0	0	0
23					45	2	5	0
24					18	0	0	0
25					26	0	3	0
26					11	0	0	0
27					24	0	2	0
28					5	0	0	0
29					34	1	4	0
30					10	0	0	0



SHORT-TERM TRAFFIC NOISE MONITORING LOG SHEET

Reading: ML-5

Project Description: 10226441 - BMCD US380 Spur399 SCH ENV

Noise Source: US 380 – University Drive Traffic Date: Dec. 14, 2021 Personnel: RMB

Equipment	Type	Serial #
Sound Level Meter	Larson Davis	824A2636
Microphone/Preamp	Larson Davis 2541; PRM902	7490
Calibrator	Larson Davis CAL200	2618

SLM SETTINGS (circle one)

FAST

SLOW

WEIGHTING (circle one)

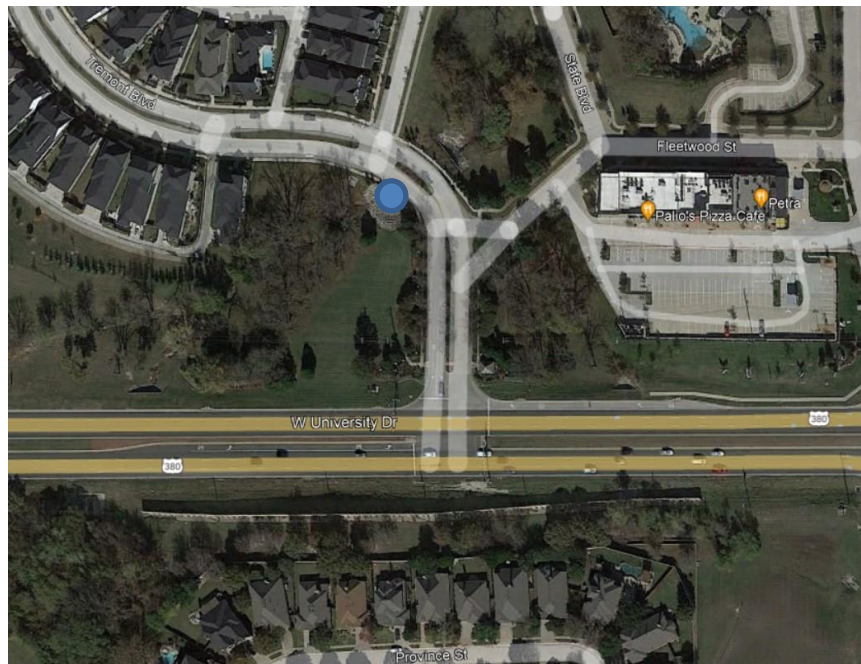
A

Lin.

Location Description: Location ML-5 – US 380 University Drive

SITE SKETCH: Including noise source, receptors, reference distances, North arrow, wind direction arrow, terrain and shielding, roadway profile, and direct lines of sight:

SLM placed on north side of roadway, ~335ft from edge of nearest travel lane of US 380. Generally acceptable line-of-site to WB traffic, but relatively shielded to EB traffic due to downhill slope away from roadway, especially farthest two lanes – no tires visible. Traffic queues for signal light.





Start Time:

11:26:00 AM PM

Stop Time:

11:55:00 AM PM

Duration:

30 minutes

Wind Speed/Direction: 9 mph S

Percentiles: _____

Temperature: 57-64 F

Humidity: 96% RH (Partly cloudy)

Calibration results before: _____ 114.2 dBA and after _____ 114.1 dBA

Traffic Count Roadway: US 380 – University Drive EB (Top Row) and WB (Bottom Row)

Autos	Medium Trucks	Heavy Trucks	Buses	Motorcycles
277 per 15 minutes	5 per 15 minutes	18 per 15 minutes	----	----
264 per 15 minutes	2 per 15 minutes	16 per 15 minutes	----	----

***Note roadway direction in table**



SHORT-TERM TRAFFIC NOISE MONITORING LOG SHEET

PROJECT: 10226441 - BMCD US380 Spur399 SCH ENV
 JOB NO.: 10226441

SITE/READING NO.: File 7

PERSONNEL: RMB

LOCATION/ADDRESS: Location ML-5

DATE: 12/14/2021

#	1 Minute Period Starting	Meas'd Leq (dBA)	v or X	Other Noise Sources	COMMENTS
1	11:26:00	58.7			
2	11:27:00	58.2			
3	11:28:00	57.7			
4	11:29:00	58.6			
5	11:30:00	59.1			
6	11:31:00	60.1			
7	11:32:00	59.0			
8	11:33:00	57.7			
9	11:34:00	58.5			
10	11:35:00	61.5			
11	11:36:00	59.6			
12	11:37:00	59.2			
13	11:38:00	60.6			
14	11:39:00	57.1			
15	11:40:00	56.5			
16	11:41:00	59.4			
17	11:42:00	61.8			
18	11:43:00	61.2			
19	11:44:00	61.5			
20	11:45:00	56.7			
21	11:46:00	61.0			
22	11:47:00	59.0			
23	11:48:00	60.7			
24	11:49:00	57.5			
25	11:50:00	58.3			
26	11:51:00	59.4			
27	11:52:00	58.8			
28	11:53:00	57.9			
29	11:54:00	58.9			
30	11:55:00	58.8			wind

TOTAL Leq = 59.3 dBA

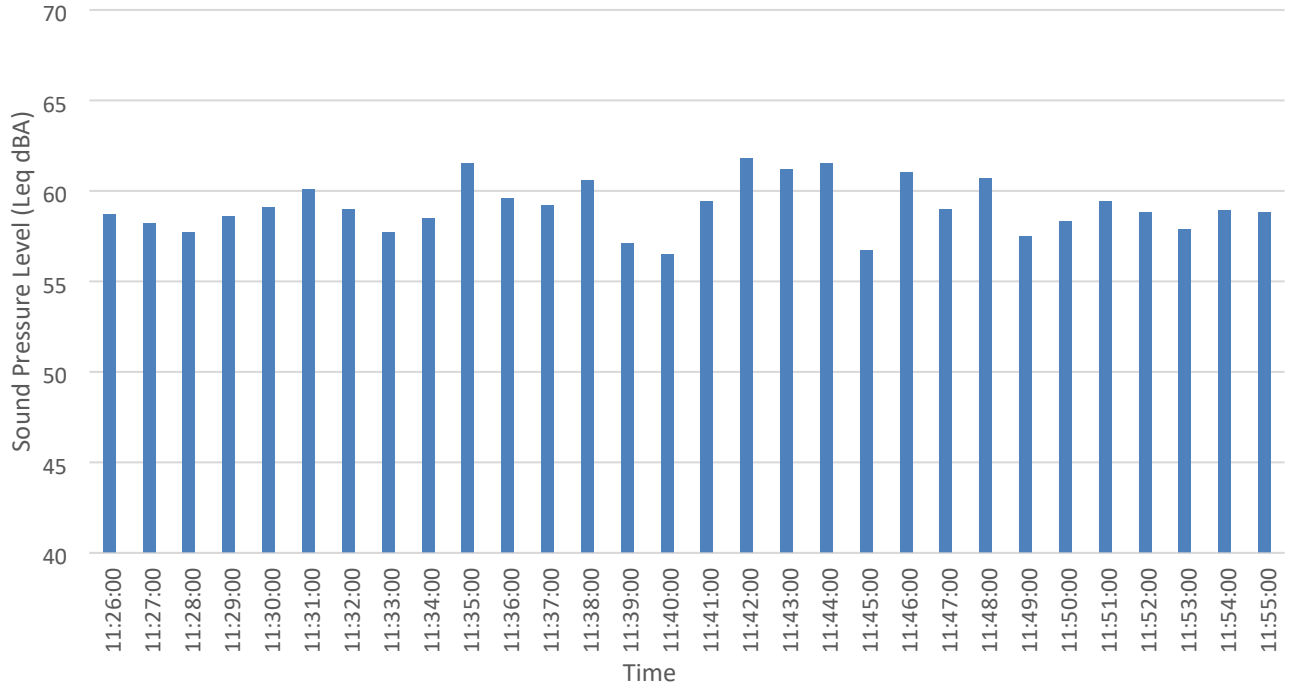
SUBSET Leq =

v = Other sources contributed to Leq X = Exclude period - contaminated by non-characteristic sources

>> ADD SKETCH AND WEATHER CONDITIONS TO REVERSE OR OTHER SHEET <<



Measured Sound Pressure Level ML-5





#	Eastbound				Westbound			
	Auto	Med	Hvy	Motorcycle	Auto	Med	Hvy	Motorcycle
1	34	0	0					
2	4	1	0					
3	35	0	2					
4	5	0	0					
5	31	0	2					
6	6	0	0					
7	26	0	2					
8	2	0	0					
9	35	2	2					
10	0	0	0					
11	42	1	3					
12	2	0	0					
13	25	0	3					
14	4	1	0					
15	26	0	4					
16					4	0	0	
17					34	0	3	
18					8	0	1	
19					23	1	0	
20					12	0	0	
21					23	0	2	
22					14	0	0	
23					31	0	3	
24					4	0	0	
25					32	0	5	
26					1	0	0	
27					34	0	1	
28					1	0	0	
29					41	1	1	
30					2	0	0	



SHORT-TERM TRAFFIC NOISE MONITORING LOG SHEET

Reading: ML-6

Project Description: 10226441 - BMCD US380 Spur399 SCH ENV

Noise Source: US 380 – University Drive Traffic Date: Dec. 14, 2021 Personnel: RMB

Equipment	Type	Serial #
Sound Level Meter	Larson Davis	824A2636
Microphone/Preamp	Larson Davis 2541; PRM902	7490
Calibrator	Larson Davis CAL200	2618

SLM SETTINGS (circle one)

FAST

SLOW

WEIGHTING (circle one)

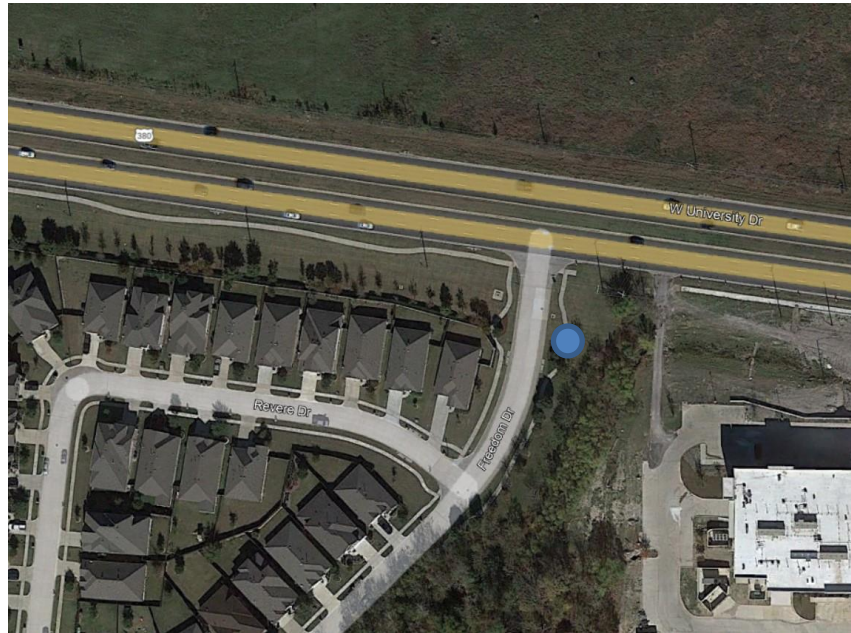
A

Lin.

Location Description: Location ML-6 – US 380 University Drive

SITE SKETCH: Including noise source, receptors, reference distances, North arrow, wind direction arrow, terrain and shielding, roadway profile, and direct lines of sight:

SLM placed on south side of roadway, ~85-90ft from edge of nearest travel lane of US 380. Good line-of-site.





Start Time:

12:55:00 AM **PM**

Stop Time:

1:24:00 AM **PM**

Duration:

30 minutes

Wind Speed/Direction: 11 mph SSE

Percentiles: _____

Temperature: 66-70 F

Humidity: 90% RH (Partly cloudy)

Calibration results before: _____114.2 dBA and after _____114.1 dBA

Traffic Count Roadway: US 380 – University Drive EB (Top Row) and WB (Bottom Row)

Autos	Medium Trucks	Heavy Trucks	Buses	Motorcycles
317 per 15 minutes	2 per 15 minutes	14 per 15 minutes	----	----
335 per 15 minutes	6 per 15 minutes	21 per 15 minutes	----	----

***Note roadway direction in table**



SHORT-TERM TRAFFIC NOISE MONITORING LOG SHEET

PROJECT: 10226441 - BMCD US380 Spur399 SCH ENV

JOB NO.: 10226441

SITE/READING NO.: File 8

PERSONNEL: RMB

LOCATION/ADDRESS: Location ML-6

DATE: 12/14/2021

#	1 Minute Period Starting	Meas'd Leq (dBA)	v or X	Other Noise Sources	COMMENTS
1	12:55:00	70.5			
2	12:56:00	67.5			
3	12:57:00	71.2			
4	12:58:00	68.0			
5	12:59:00	74.7			
6	13:00:00	63.6			
7	13:01:00	72.4			
8	13:02:00	66.1			
9	13:03:00	70.0			
10	13:04:00	66.1			
11	13:05:00	71.5			
12	13:06:00	66.5			
13	13:07:00	72.3			
14	13:08:00	65.3			
15	13:09:00	71.5			
16	13:10:00	66.5			
17	13:11:00	70.5			
18	13:12:00	66.3			
19	13:13:00	72.4			
20	13:14:00	65.6			
21	13:15:00	72.3			
22	13:16:00	65.1			
23	13:17:00	72.7			
24	13:18:00	66.3			
25	13:19:00	71.3			
26	13:20:00	69.6			
27	13:21:00	72.5			
28	13:22:00	70.3			
29	13:23:00	72.6			
30	13:24:00	67.3			wind

TOTAL Leq = 70.2 dBA

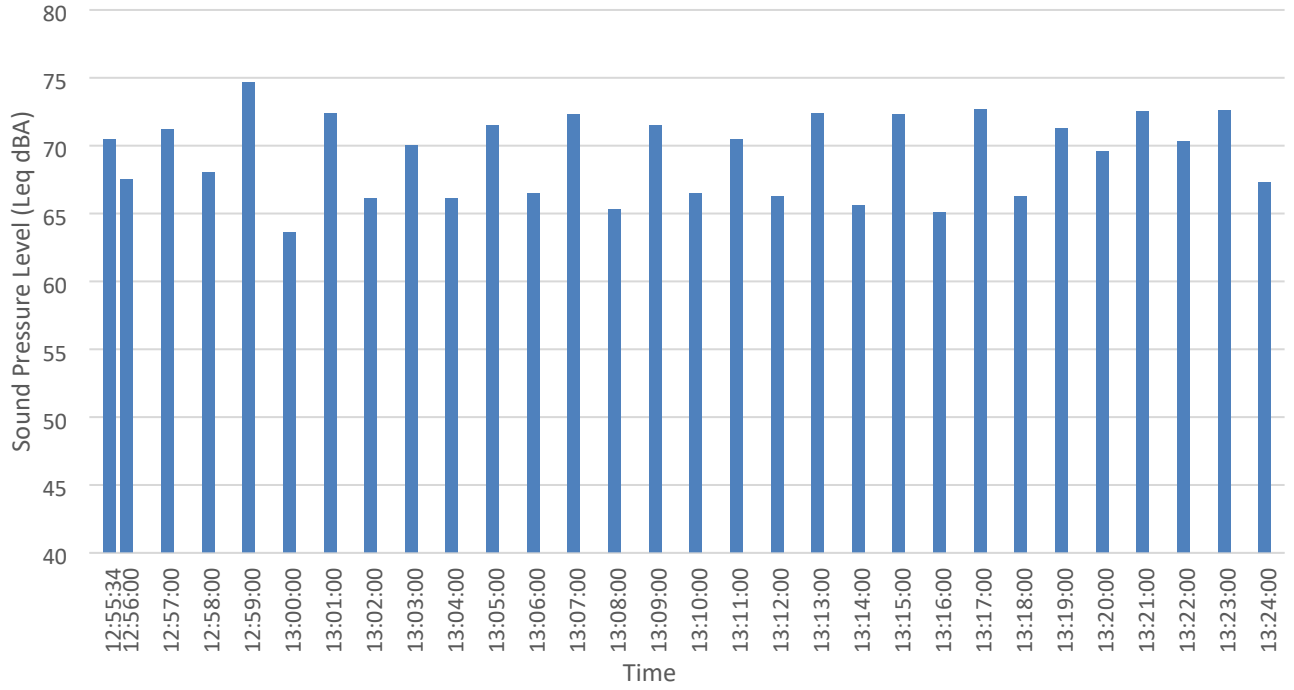
SUBSET Leq =

v = Other sources contributed to Leq X = Exclude period - contaminated by non-characteristic sources

>> ADD SKETCH AND WEATHER CONDITIONS TO REVERSE OR OTHER SHEET <<



Measured Sound Pressure Level ML-6





#	Eastbound				Westbound			
	Auto	Med	Hvy	Motorcycle	Auto	Med	Hvy	Motorcycle
1	10	0	0					
2	38	0	1					
3	3	0	0					
4	35	0	5					
5	8	1	0					
6	41	0	1					
7	8	0	1					
8	34	0	0					
9	13	0	1					
10	28	1	2					
11	6	0	0					
12	38	0	2					
13	17	0	1					
14	29	0	0					
15	9	0	0					
16					22	0	1	
17					30	0	1	
18					24	0	2	
19					26	2	2	
20					8	0	0	
21					30	0	2	
22					10	1	1	
23					21	0	1	
24					9	0	2	
25					51	0	3	
26					10	2	0	
27					34	1	2	
28					11	0	0	
29					35	0	4	
30					14	0	0	



SHORT-TERM TRAFFIC NOISE MONITORING LOG SHEET

Reading: ML-9

Project Description: 10226441 - BMCD US380 Spur399 SCH ENV

Noise Source: TX 123 Date: Dec. 14, 2021

Personnel: RMB

Equipment	Type	Serial #
Sound Level Meter	Larson Davis	824A2636
Microphone/Preamp	Larson Davis 2541; PRM902	7490
Calibrator	Larson Davis CAL200	2618

SLM SETTINGS (circle one)

FAST

SLOW

WEIGHTING (circle one)

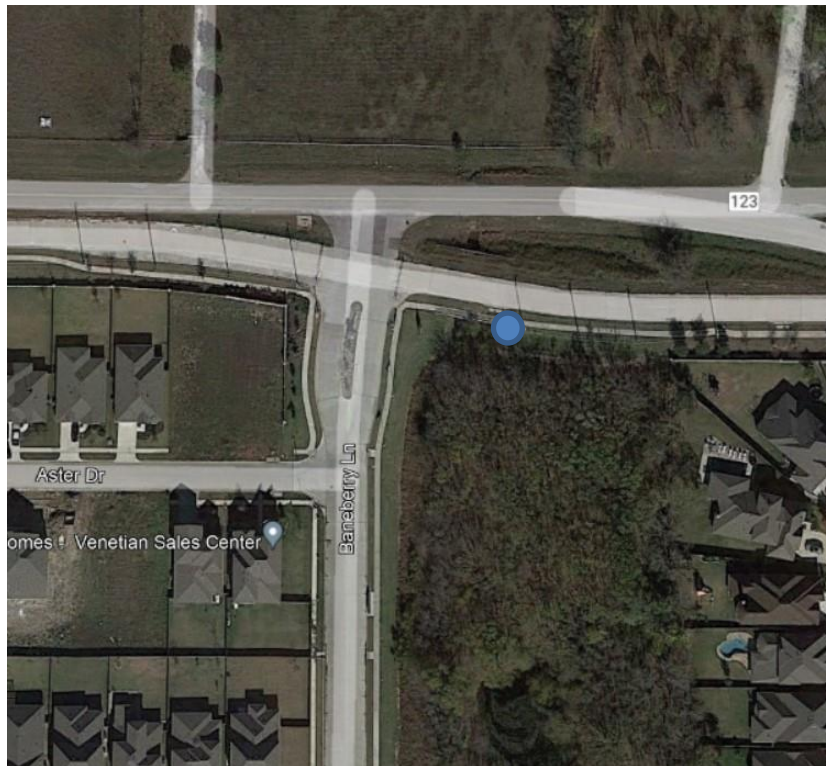
A

Lin.

Location Description: Location ML-9 – TX 123

SITE SKETCH: Including noise source, receptors, reference distances, North arrow, wind direction arrow, terrain and shielding, roadway profile, and direct lines of sight:

SLM placed on south side of roadway (near side walk, ~100ft from edge of nearest travel lane of TX 123. Good line-of-site to WB traffic.





Start Time:

3:27:00 AM **PM**

Stop Time:

3:56:00 AM **PM**

Duration:

30 minutes

Wind Speed/Direction: 9 mph S

Percentiles: _____

Temperature: 57-64 F

Humidity: 96% RH (Partly cloudy)

Calibration results before: _____ 114.2 dBA and after _____ 114.1 dBA

Traffic Count Roadway: TX 123 EB (Top Row) and WB (Bottom Row)

Autos	Medium Trucks	Heavy Trucks	Buses	Motorcycles
87 per 30 minutes	3 per 30 minutes	1 per 30 minutes	----	----
52 per 30 minutes	0 per 30 minutes	1 per 30 minutes	----	----

***Note roadway direction in table**



SHORT-TERM TRAFFIC NOISE MONITORING LOG SHEET

PROJECT: 10226441 - BMCD US380 Spur399 SCH ENV

JOB NO.: 10226441

SITE/READING NO.: File 11

PERSONNEL: RMB

LOCATION/ADDRESS: Location ML-9

DATE: 12/14/2021

#	1 Minute Period Starting	Meas'd Leq (dBA)	v or X	Other Noise Sources	COMMENTS
1	15:27:00	47.3			
2	15:28:00	54.9			
3	15:29:00	54.6			
4	15:30:00	54.8			
5	15:31:00	52.3			
6	15:32:00	56.4			Distant plane
7	15:33:00	55.6			
8	15:34:00	53.4			
9	15:35:00	54.1			
10	15:36:00	54.1			
11	15:37:00	56.1			Distant plane
12	15:38:00	55.6			
13	15:39:00	52.2			
14	15:40:00	55.4			
15	15:41:00	59.3			Trailer noise from pick-up truck
16	15:42:00	55.2			
17	15:43:00	55.1			
18	15:44:00	55.3			
19	15:45:00	53.6			Distant plane
20	15:46:00	57.3			
21	15:47:00	53.0			
22	15:48:00	54.1			Plane
23	15:49:00	52.3			Plane
24	15:50:00	47.0			Flag poles – clanging
25	15:51:00	52.0			
26	15:52:00	56.4			
27	15:53:00	58.4			Distant plane
28	15:54:00	55.8			
29	15:55:00	56.8			
30	15:56:00	57.4			

TOTAL Leq = 55.2 dBA

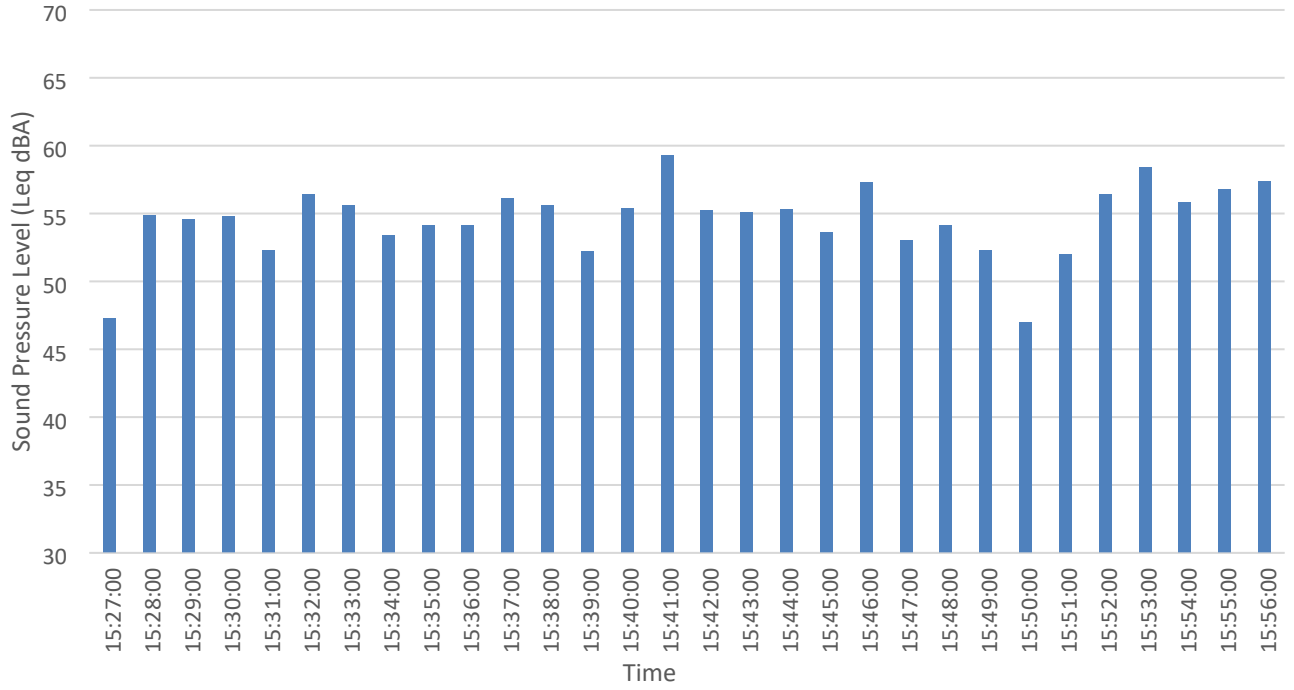
SUBSET Leq =

v = Other sources contributed to Leq X = Exclude period - contaminated by non-characteristic sources

>> ADD SKETCH AND WEATHER CONDITIONS TO REVERSE OR OTHER SHEET <<



Measured Sound Pressure Level ML-9





#	Eastbound				Westbound			
	Auto	Med	Hvy	Motorcycle	Auto	Med	Hvy	Motorcycle
1	2	1	0		0	0	0	
2	3	0	0		1	0	0	
3	1	0	0		5	0	0	
4	4	0	0		1	0	0	
5	2	0	1		1	0	0	
6	5	1	0		1	0	0	
7	2	0	0		2	0	0	
8	3	0	0		1	0	0	
9	3	0	0		5	0	0	
10	4	0	0		2	0	0	
11	2	0	0		4	0	0	
12	3	0	0		2	0	0	
13	3	0	0		1	0	0	
14	2	0	0		3	0	0	
15	4	0	0		3	0	0	
16	3	0	0		1	0	0	
17	6	1	0		0	0	0	
18	3	0	0		4	0	0	
19	3	0	0		2	0	0	
20	2	0	0		0	0	0	
21	2	0	0		1	0	0	
22	3	0	0		0	0	0	
23	0	0	0		0	0	0	
24	2	0	0		0	0	0	
25	4	0	0		1	0	0	
26	6	0	0		2	0	0	
27	2	0	0		2	0	0	
28	3	0	0		1	0	0	
29	1	0	0		4	0	1	
30	4	0	0		2	0	0	



SHORT-TERM TRAFFIC NOISE MONITORING LOG SHEET

Reading: ML-15

Project Description: 10226441 - BMCD US380 Spur399 SCH ENV

Noise Source: TX 2933 Date: Dec. 16, 2021 Personnel: RMB

Equipment	Type	Serial #
Sound Level Meter	Larson Davis	824A2636
Microphone/Preamp	Larson Davis 2541; PRM902	7490
Calibrator	Larson Davis CAL200	2618

SLM SETTINGS (circle one)

FAST

SLOW

WEIGHTING (circle one)

A

Lin.

Location Description: Location ML-15 – TX 2933

SITE SKETCH: Including noise source, receptors, reference distances, North arrow, wind direction arrow, terrain and shielding, roadway profile, and direct lines of sight:

SLM placed along TX 2933, ~165ft from edge of nearest travel lane.





Start Time:

2:51:15 AM (PM)

Stop Time:

3:20:15 AM (PM)

Duration:

30 minutes

Wind Speed/Direction: 9 mph N

Percentiles: _____

Temperature: 63-70 F

Humidity: 46% RH (partly cloudy)

Calibration results before: _____ 114.0 dBA and after _____ 114.0 dBA

Traffic Count Roadway: TX 2933 SB (Top Row) and NB (Bottom Row)

Autos	Medium Trucks	Heavy Trucks	Buses	Motorcycles
25 per 30 minutes	2 per 30 minutes	3 per 30 minutes	2 per 30 minutes	----
23 per 30 minutes	1 per 30 minutes	5 per 30 minutes	----	----

***Note roadway direction in table**



SHORT-TERM TRAFFIC NOISE MONITORING LOG SHEET

PROJECT: 10226441 - BMCD US380 Spur399 SCH ENV
 JOB NO.: 10226441

SITE/READING NO.: File 19

PERSONNEL: RMB

LOCATION/ADDRESS: Location ML-15

DATE: 12/16/2021

#	1 Minute Period Starting	Meas'd Leq (dBA)	v or X	Other Noise Sources	COMMENTS
1	14:51:15	54.9			
2	14:52:15	49.6			
3	14:53:15	49.5			
4	14:54:15	45.3			
5	14:55:15	52.8			Plane
6	14:56:15	53.0			Overhead plane
7	14:57:15	68.1			Overhead plane
8	14:58:15	43.8			
9	14:59:15	55.2			
10	15:00:15	60.4			
11	15:01:15	53.8			
12	15:02:15	59.6			
13	15:03:15	56.2			Distant plane
14	15:04:15	58.1			
15	15:05:15	48.2			
16	15:06:15	43.4			Plane
17	15:07:15	59.9			
18	15:08:15	53.3			Distant plane
19	15:09:15	49.8			Distant plane
20	15:10:15	54.0			
21	15:11:15	45.8			Distant plane
22	15:12:15	56.4			
23	15:13:15	57.4			Plane
24	15:14:15	44.1			
25	15:15:15	54.4			
26	15:16:15	55.7			Distant jet
27	15:17:15	55.6			
28	15:18:15	54.8			Distant jet
29	15:19:15	53.8			Distant plane
30	15:20:15	58.0			

TOTAL Leq = 57.3 dBA

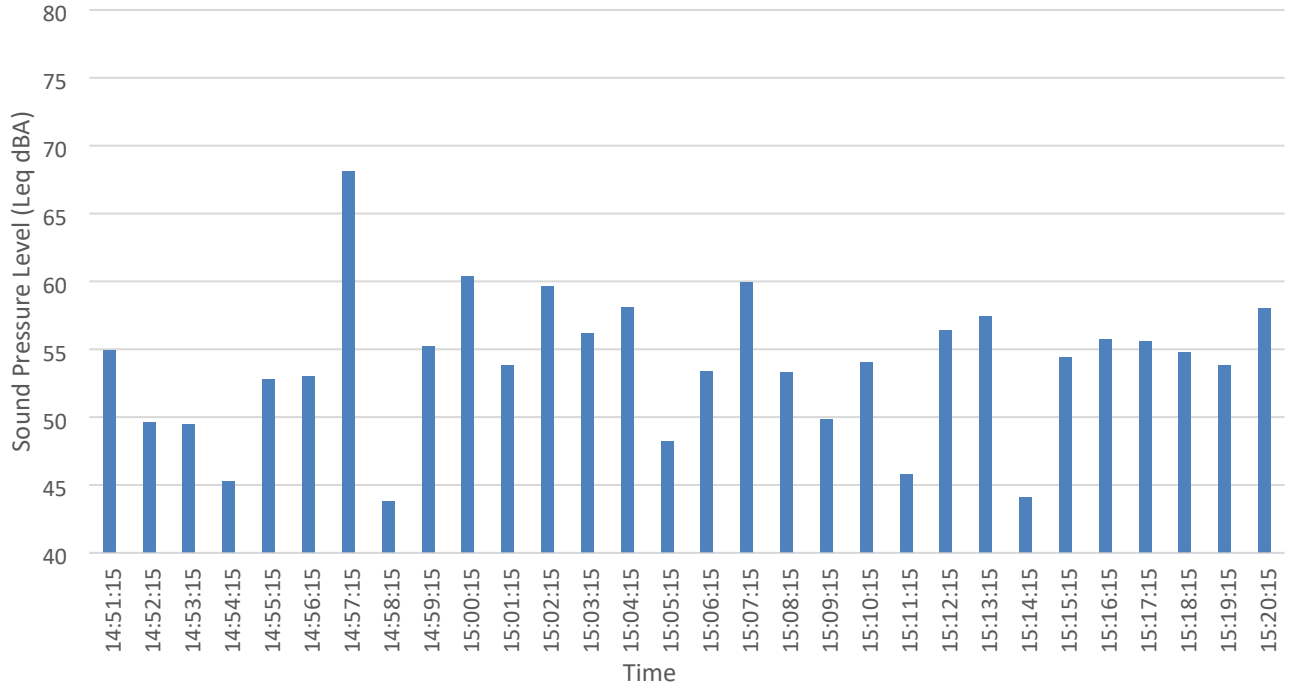
SUBSET Leq =

v = Other sources contributed to Leq X = Exclude period - contaminated by non-characteristic sources

>> ADD SKETCH AND WEATHER CONDITIONS TO REVERSE OR OTHER SHEET <<



Measured Sound Pressure Level ML-15





#	Southbound				Northbound			
	Auto	Med	Hvy	Motorcycle	Auto	Med	Hvy	Motorcycle
1	1	0	0		0	1	0	
2	0	0	0		1	0	0	
3	0	0	0		1	0	0	
4	0	0	0		0	0	0	
5	0	0	0		1	0	0	
6	1	0	0		0	0	0	
7	1	0	0		2	0	0	
8	0	0	0		0	0	0	
9	2	0	0		3	0	1	
10	3	0	0		1	0	0	
11	2	0	0		1	0	0	
12	2	1	0		0	0	0	
13	0	0	0		2	0	0	
14	2	0	0		0	0	0	
15	1	0	0		0	0	0	
16	1	0	0		0	0	2	
17	0	0	0		0	0	0	
18	1	0	0		1	0	0	
19	2	0	0		0	0	0	
20	0	0	0		1	0	0	
21	0	1	0		0	0	0	
22	0	0	1		2	0	0	
23	0	0	0		0	0	0	
24	0	0	1		1	0	0	
25	2	0	0		1	0	0	
26	1	0	0		2	0	0	
27	1	0	0		2	0	0	
28	0	0	0		0	0	0	
29	2	0	0		1	0	0	
30	0	0	1		0	0	2	



SHORT-TERM TRAFFIC NOISE MONITORING LOG SHEET

Reading: ML-17

Project Description: 10226441 - BMCD US380 Spur399 SCH ENV

Noise Source: US 75 Date: Dec. 16, 2021

Personnel: RMB

Equipment	Type	Serial #
Sound Level Meter	Larson Davis	824A2636
Microphone/Preamp	Larson Davis 2541; PRM902	7490
Calibrator	Larson Davis CAL200	2618

SLM SETTINGS (circle one)

FAST

SLOW

WEIGHTING (circle one)

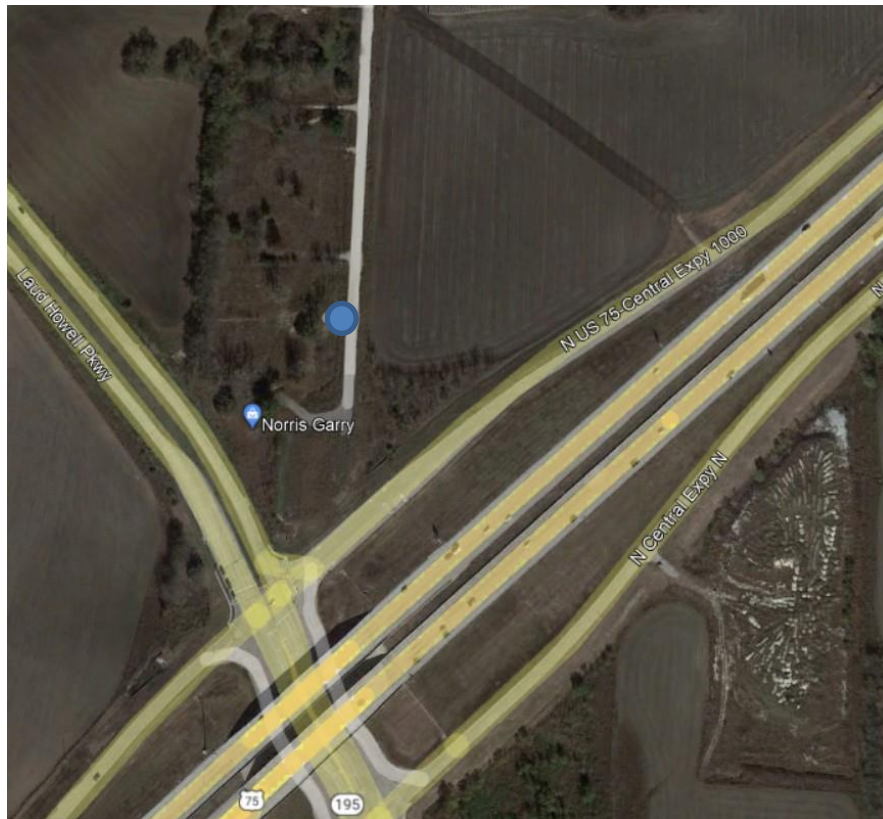
A

Lin.

Location Description: Location ML-17 – US 75

SITE SKETCH: Including noise source, receptors, reference distances, North arrow, wind direction arrow, terrain and shielding, roadway profile, and direct lines of sight:

SLM placed on west side of roadway, ~555ft from edge of nearest travel lane of US 75. Relatively poor line-of-site to traffic, especially to NB traffic.





Start Time:

10:15:00 AM PM

Stop Time:

10:44:00 AM PM

Duration:

30 minutes

Wind Speed/Direction: 11 mph SSW

Percentiles: _____

Temperature: 66-75 F

Humidity: 73% RH (partly sunny)

Calibration results before: _____ 114.0 dBA and after _____ 114.0 dBA

Traffic Count Roadway: US 75 SB (Top Row) and NB (Bottom Row)

Autos	Medium Trucks	Heavy Trucks	Buses	Motorcycles
845 per 15 minutes	9 per 15 minutes	85 per 15 minutes	----	----
681 per 15 minutes	4 per 15 minutes	98 per 15 minutes	----	----

***Note roadway direction in table**



SHORT-TERM TRAFFIC NOISE MONITORING LOG SHEET

PROJECT: 10226441 - BMCD US380 Spur399 SCH ENV

JOB NO.: 10226441

SITE/READING NO.: File 14

PERSONNEL: RMB

LOCATION/ADDRESS: Location ML-17

DATE: 12/16/2021

#	1 Minute Period Starting	Meas'd Leq (dBA)	v or X	Other Noise Sources	COMMENTS
1	10:15:00	66.8			
2	10:16:00	68.9			
3	10:17:00	69.0			
4	10:18:00	66.5			
5	10:19:00	66.1			
6	10:20:00	67.6			
7	10:21:00	66.3			
8	10:22:00	68.1			
9	10:23:00	66.9			
10	10:24:00	66.9			
11	10:25:00	67.8			
12	10:26:00	67.3			
13	10:27:00	66.9			
14	10:28:00	68.2			
15	10:29:00	67.6			
16	10:30:00	68.4			
17	10:31:00	69.2			
18	10:32:00	67.1			
19	10:33:00	67.3			
20	10:34:00	61.4			
21	10:35:00	62.0			
22	10:36:00	61.4			
23	10:37:00	62.8			
24	10:38:00	61.1			
25	10:39:00	61.6			
26	10:40:00	62.4			
27	10:41:00	62.6			
28	10:42:00	61.9			
29	10:43:00	61.5			
30	10:44:00	62.6			

TOTAL Leq = 66.3 dBA

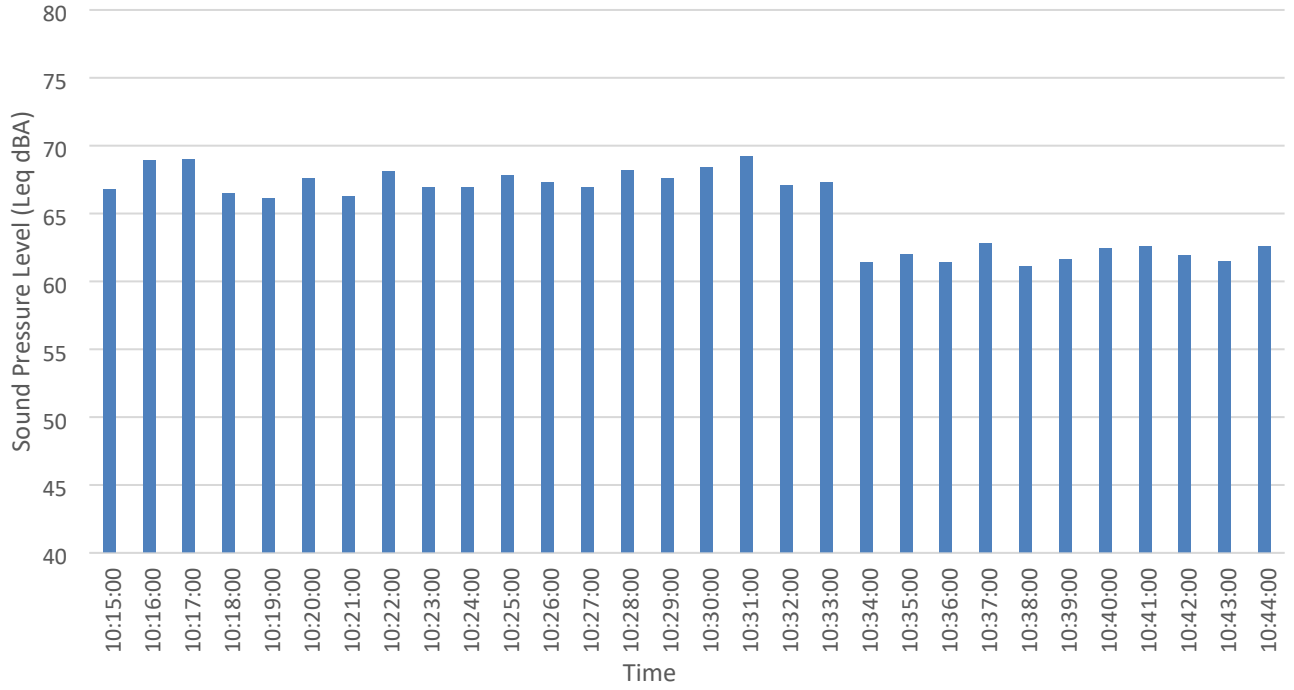
SUBSET Leq =

v = Other sources contributed to Leq X = Exclude period - contaminated by non-characteristic sources

>> ADD SKETCH AND WEATHER CONDITIONS TO REVERSE OR OTHER SHEET <<



Measured Sound Pressure Level ML-17





#	Southbound				Northbound			
	Auto	Med	Hvy	Motorcycle	Auto	Med	Hvy	Motorcycle
1	51	0	4					
2	65	0	8					
3	55	0	11					
4	42	0	4					
5	36	0	3					
6	64	1	3					
7	56	0	6					
8	72	1	5					
9	50	2	9					
10	50	0	5					
11	52	1	3					
12	50	2	5					
13	64	1	7					
14	78	0	7					
15	60	1	5					
16					37	0	13	
17					43	0	9	
18					35	0	9	
19					36	0	6	
20					40	0	7	
21					48	0	6	
22					34	0	3	
23					56	0	9	
24					58	1	10	
25					54	1	5	
26					50	0	5	
27					48	0	3	
28					52	1	7	
29					46	0	5	
30					44	1	1	



SHORT-TERM TRAFFIC NOISE MONITORING LOG SHEET

Reading: ML-18

Project Description: 10226441 - BMCD US380 Spur399 SCH ENV

Noise Source: US 75 Date: Dec. 16, 2021

Personnel: RMB

Equipment	Type	Serial #
Sound Level Meter	Larson Davis	824A2636
Microphone/Preamp	Larson Davis 2541; PRM902	7490
Calibrator	Larson Davis CAL200	2618

SLM SETTINGS (circle one)

FAST

SLOW

WEIGHTING (circle one)

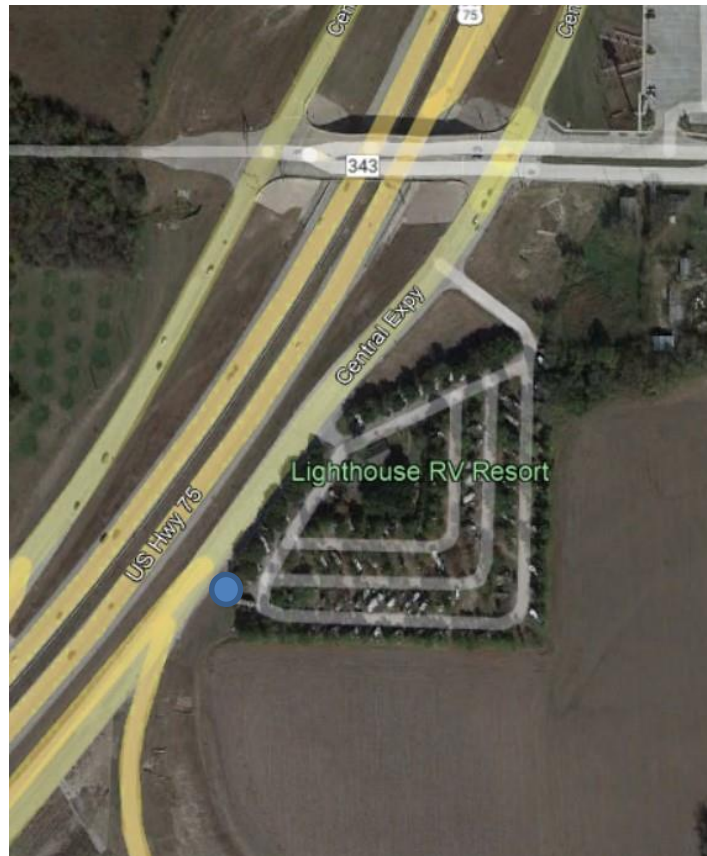
A

Lin.

Location Description: Location ML-18 – US 75

SITE SKETCH: Including noise source, receptors, reference distances, North arrow, wind direction arrow, terrain and shielding, roadway profile, and direct lines of sight:

SLM placed on east side of roadway at top of berm, ~150ft from edge of nearest NB travel lane of US 75. Relatively good line-of-site to traffic.





Start Time:

2:03:53 AM **PM**

Stop Time:

2:32:53 AM **PM**

Duration:

30 minutes

Wind Speed/Direction: 11 mph SSW

Percentiles: _____

Temperature: 66-75 F

Humidity: 73% RH (partly sunny)

Calibration results before: _____114.0 dBA and after _____114.0 dBA

Traffic Count Roadway: US 75 SB (Top Row) and NB (Bottom Row)

Autos	Medium Trucks	Heavy Trucks	Buses	Motorcycles
545 per 15 minutes	5 per 15 minutes	63 per 15 minutes	----	----
420 per 15 minutes	8 per 15 minutes	23 per 15 minutes	----	----

***Note roadway direction in table**



SHORT-TERM TRAFFIC NOISE MONITORING LOG SHEET

PROJECT: 10226441 - BMCD US380 Spur399 SCH ENV

JOB NO.: 10226441

SITE/READING NO.: File 15

PERSONNEL: RMB

LOCATION/ADDRESS: Location ML-18

DATE: 12/16/2021

#	1 Minute Period Starting	Meas'd Leq (dBA)	v or X	Other Noise Sources	COMMENTS
1	14:03:53	75.7			
2	14:04:53	75.1			
3	14:05:53	76.5			
4	14:06:53	75.7			
5	14:07:53	76.4			
6	14:08:53	75.6			
7	14:09:53	76.5			
8	14:10:53	76.3			
9	14:11:53	76.0			
10	14:12:53	76.1			
11	14:13:53	76.3			
12	14:14:53	76.5			
13	14:15:53	76.4			
14	14:16:53	76.9			
15	14:17:53	77.7			
16	14:18:53	75.9			
17	14:19:53	76.3			
18	14:20:53	74.8			
19	14:21:53	76.0			
20	14:22:53	75.8			
21	14:23:53	76.3			
22	14:24:53	76.6			
23	14:25:53	76.4			
24	14:26:53	76.5			
25	14:27:53	76.6			Wind
26	14:28:53	76.5			
27	14:29:53	78.6			Wind
28	14:30:53	77.8			Wind
29	14:31:53	76.4			Wind
30	14:32:53	77.3			

TOTAL Leq = 76.5 dBA

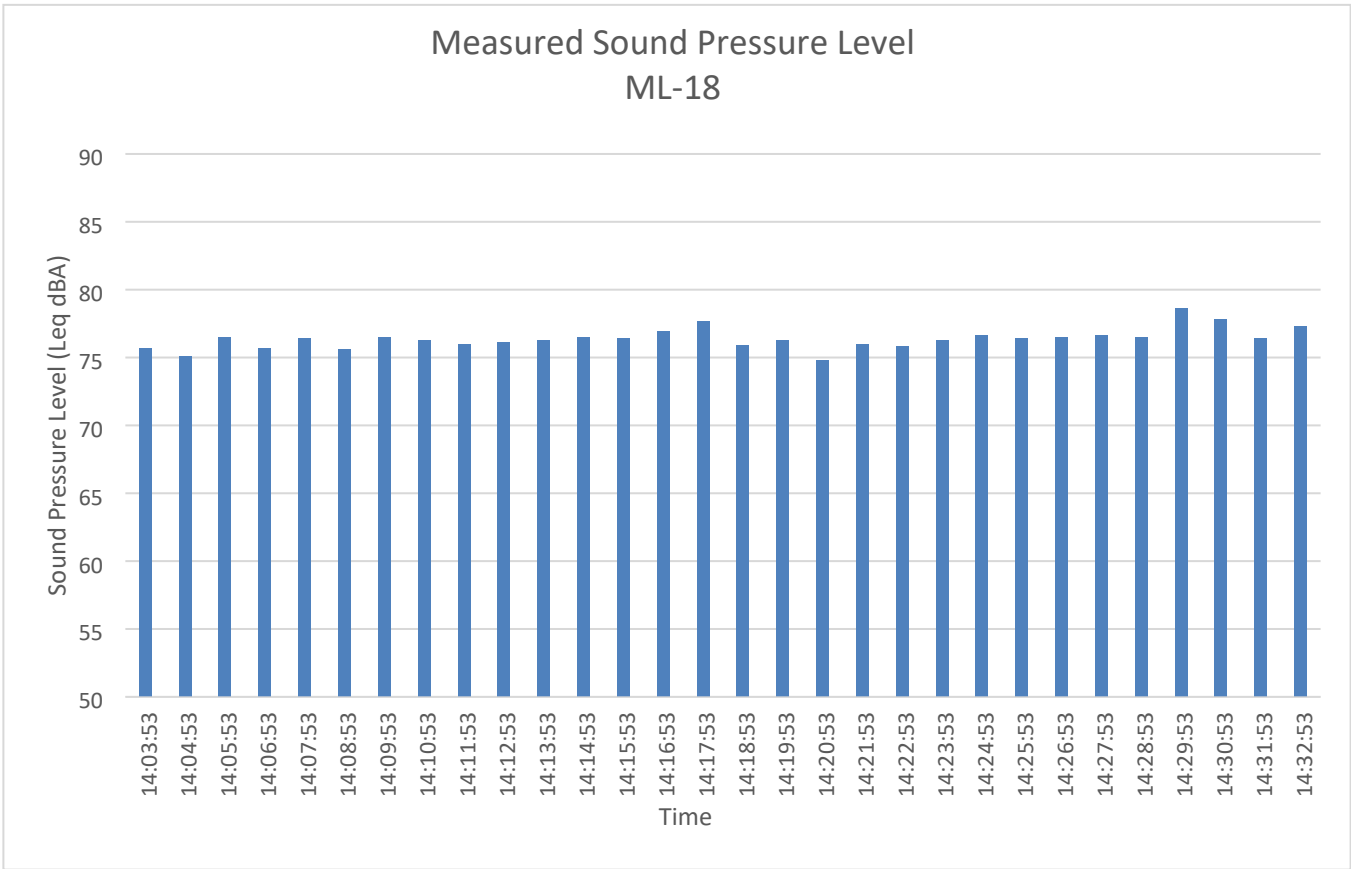
SUBSET Leq =

v = Other sources contributed to Leq

X = Exclude period - contaminated by non-characteristic sources



>> ADD SKETCH AND WEATHER CONDITIONS TO REVERSE OR OTHER SHEET <<





#	Southbound				Northbound			
	Auto	Med	Hvy	Motorcycle	Auto	Med	Hvy	Motorcycle
1					34	1	1	
2					26	0	2	
3					33	1	7	
4					21	0	4	
5					32	0	4	
6					32	1	3	
7					27	0	8	
8					25	1	8	
9					26	1	5	
10					21	0	4	
11					27	1	5	
12					28	1	5	
13					23	0	4	
14					39	1	4	
15					26	0	9	
16	34	0	6					
17	32	0	3					
18	41	0	2					
19	28	0	6					
20	33	0	6					
21	38	0	6					
22	47	1	5					
23	34	0	4					
24	36	0	4					
25	65	1	3					
26	34	0	5					
27	25	1	3					
28	33	0	3					
29	38	1	4					
30	27	1	3					

Attachment D – Ambient Noise Measurement

Additionally, background noise measurements were taken at five locations, as listed in **Table D-1** below. These measurements were performed during the same measurement timeframe and under the same conditions as described for the traffic noise measurements above.

Table D-1. Background Levels dB(A) Leq

Location	Measurement Site	Field-Measured Level dB(A) Leq
ML-7	Nature Nate Farms Rd.	46.6
ML-10	Hardin Blvd.	51.6
ML-16	TX 338	52.4



SHORT-TERM TRAFFIC NOISE MONITORING LOG SHEET

Reading: ML-7

Project Description: 10226441 - BMCD US380 Spur399 SCH ENV

Noise Source: Background Noise Date: Dec. 14, 2021 Personnel: RMB

Equipment	Type	Serial #
Sound Level Meter	Larson Davis	824A2636
Microphone/Preamp	Larson Davis 2541; PRM902	7490
Calibrator	Larson Davis CAL200	2618

SLM SETTINGS (circle one)

FAST

SLOW

WEIGHTING (circle one)

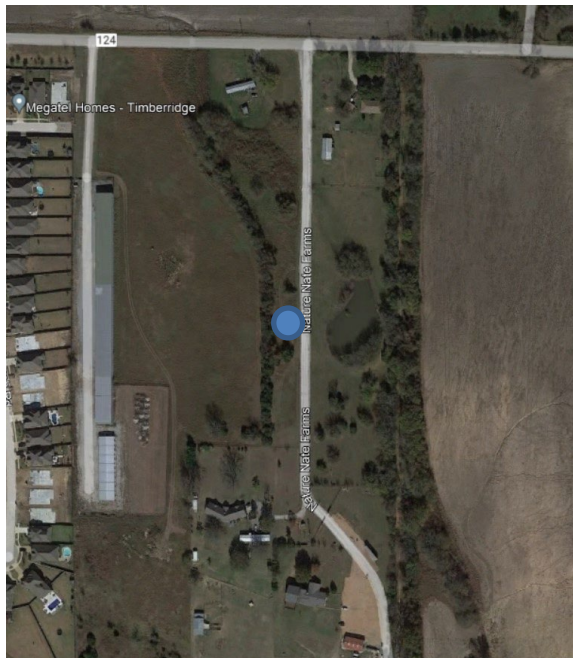
A

Lin.

Location Description: Location ML-7

SITE SKETCH: Including noise source, receptors, reference distances, North arrow, wind direction arrow, terrain and shielding, roadway profile, and direct lines of sight:

SLM placed along Nature Nate Farms Road (~5ft from roadway). Limited traffic ; SLM paused for vehicle pass-bys. Ambient noise sources include: distant aircraft, distant traffic, birds, leaves, distant construction back-up beepers, insects.





Start Time:

Stop Time:

Duration:

2:40:06 AM **PM**

3:10:00 AM **PM**

30 minutes

Wind Speed/Direction: 11 mph SSE

Percentiles: _____

Temperature: 66-70 F

Humidity: 90% RH (Partly cloudy)

Calibration results before: _____114.2 dBA and after _____114.1 dBA

Traffic Count Roadway: Background Noise

Autos	Medium Trucks	Heavy Trucks	Buses	Motorcycles

***Note roadway direction in table**



SHORT-TERM TRAFFIC NOISE MONITORING LOG SHEET

PROJECT: 10226441 - BMCD US380 Spur399 SCH ENV
 JOB NO.: 10226441

SITE/READING NO.: File 10

PERSONNEL: RMB

LOCATION/ADDRESS: Location ML-7

DATE: 12/14/2021

#	1 Minute Period Starting	Meas'd Leq (dBA)	v or X	Other Noise Sources	COMMENTS
1	14:40:06	44.3			
2	14:41:06	48.9			
3	14:42:06	45.0			Wind
4	14:43:06	49.0			Distant motorbike
5	14:44:06	50.0			
6	14:45:06	45.8			
7	14:46:06	46.5			Wind / distant aircraft
8	14:47:06	48.6			Wind
9	14:49:00	45.7			Wind
10	14:50:00	47.8			
11	14:51:00	48.8			
12	14:52:00	47.3			
13	14:53:00	45.9			
14	14:54:00	46.5			
15	14:55:00	45.1			
16	14:56:00	44.3			
17	14:57:00	44.5			
18	14:58:00	43.7			
19	14:59:00	43.6			
20	15:00:00	43.1			Horn
21	15:01:00	46.5			Wind
22	15:02:00	45.6			Plane
23	15:03:00	44.8			
24	15:04:00	47.6			
25	15:05:00	50.7			
26	15:06:00	44.0			
27	15:07:00	46.3			Plane
28	15:08:00	43.5			
29	15:09:00	47.4			
30	15:10:00	46.0			

TOTAL Leq = 46.6 dBA

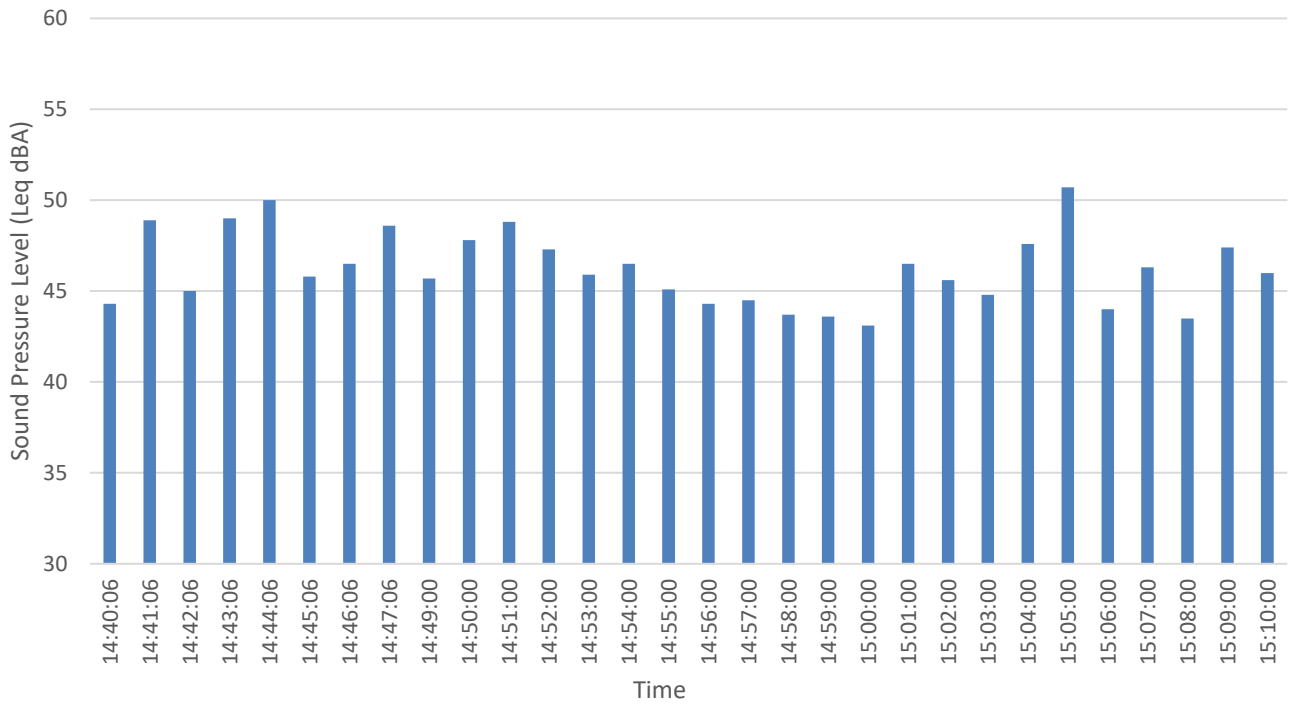
SUBSET Leq =

v = Other sources contributed to Leq X = Exclude period - contaminated by non-characteristic sources

>> ADD SKETCH AND WEATHER CONDITIONS TO REVERSE OR OTHER SHEET <<



Measured Sound Pressure Level ML-7





SHORT-TERM TRAFFIC NOISE MONITORING LOG SHEET

Reading: ML-10

Project Description: 10226441 - BMCD US380 Spur399 SCH ENV

Noise Source: Background Noise Date: Dec. 16, 2021 Personnel: RMB

Equipment	Type	Serial #
Sound Level Meter	Larson Davis	824A2636
Microphone/Preamp	Larson Davis 2541; PRM902	7490
Calibrator	Larson Davis CAL200	2618

SLM SETTINGS (circle one)

FAST

SLOW

WEIGHTING (circle one)

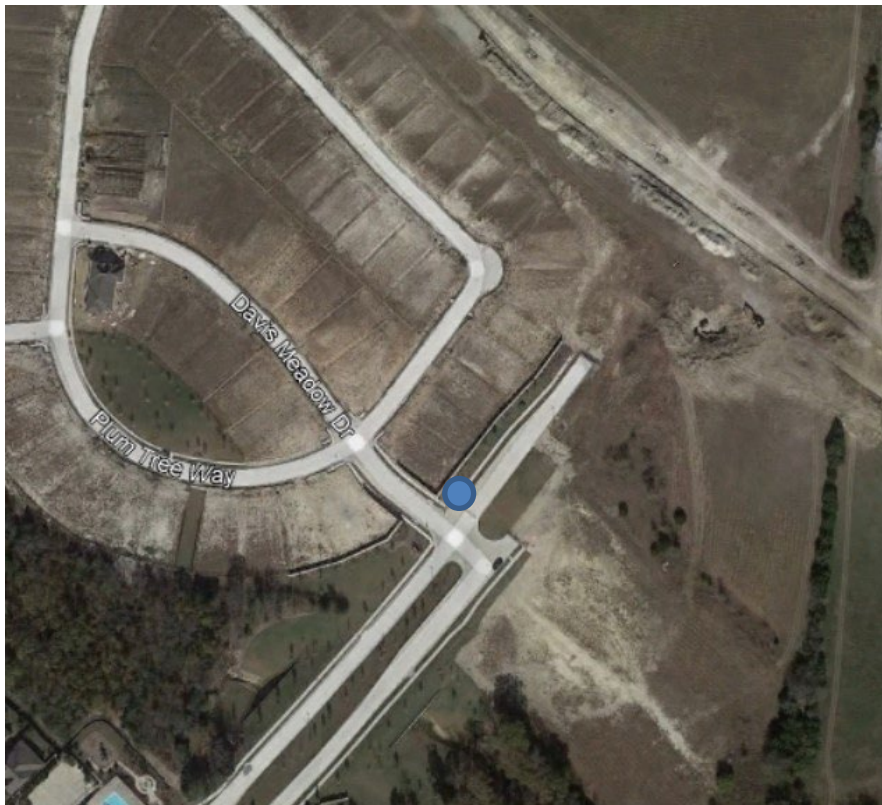
A

Lin.

Location Description: Location ML-10 – Background Noise

SITE SKETCH: Including noise source, receptors, reference distances, North arrow, wind direction arrow, terrain and shielding, roadway profile, and direct lines of sight:

SLM placed at end of Hardin Blvd. Typical noise sources included distant residential construction, distant aircraft, distant heavy equipment, birds, distant traffic, back-up beepers. Typical ambient in 40 dBA range.





Start Time:

9:25:45 (AM) PM

Stop Time:

9:54:45 (AM) PM

Duration:

30 minutes

Wind Speed/Direction: 11 mph SSW

Percentiles: _____

Temperature: 66-75 F

Humidity: 73% RH (partly sunny)

Calibration results before: _____ 114.0 dBA and after _____ 114.0 dBA

Traffic Count Roadway:

Autos	Medium Trucks	Heavy Trucks	Buses	Motorcycles

***Note roadway direction in table**



SHORT-TERM TRAFFIC NOISE MONITORING LOG SHEET

PROJECT: 10226441 - BMCD US380 Spur399 SCH ENV

JOB NO.: 10226441

SITE/READING NO.: File 13

PERSONNEL: RMB

LOCATION/ADDRESS: Location ML-10

DATE: 12/16/2021

#	1 Minute Period Starting	Meas'd Leq (dBA)	v or X	Other Noise Sources	COMMENTS
1	9:25:45	46.1			Hammering – residential construction
2	9:26:45	46.5			
3	9:27:45	46.4			
4	9:28:45	48.5			
5	9:29:45	51.7			
6	9:30:45	46.8			Car passby
7	9:31:45	46.2			Car passby
8	9:32:45	51.8			
9	9:33:45	50.0			
10	9:34:45	51.8			Car passby
11	9:35:45	55.4			
12	9:36:45	56.6			Car passby
13	9:37:45	52.1			Car passby
14	9:38:45	52.3			Car passby
15	9:39:45	47.3			Compressor on
16	9:40:45	47.3			Compressor on
17	9:41:45	47.9			
18	9:42:45	53.8			Compressor on – off
19	9:43:45	53.6			Compressor on – off
20	9:44:45	55.9			
21	9:45:45	54.1			Plane
22	9:46:45	46.6			Compressor on – off, car passby (3x)
23	9:47:45	52.3			Compressor on - off
24	9:48:45	50.9			
25	9:49:45	51.6			
26	9:50:45	76.9	X		Siren
27	9:51:45	73.1	X		Siren
28	9:52:45	70.4	X		Siren off
29	9:53:45	47.2			
30	9:54:45	48.6			Plane

TOTAL Leq = 64.5 dBA

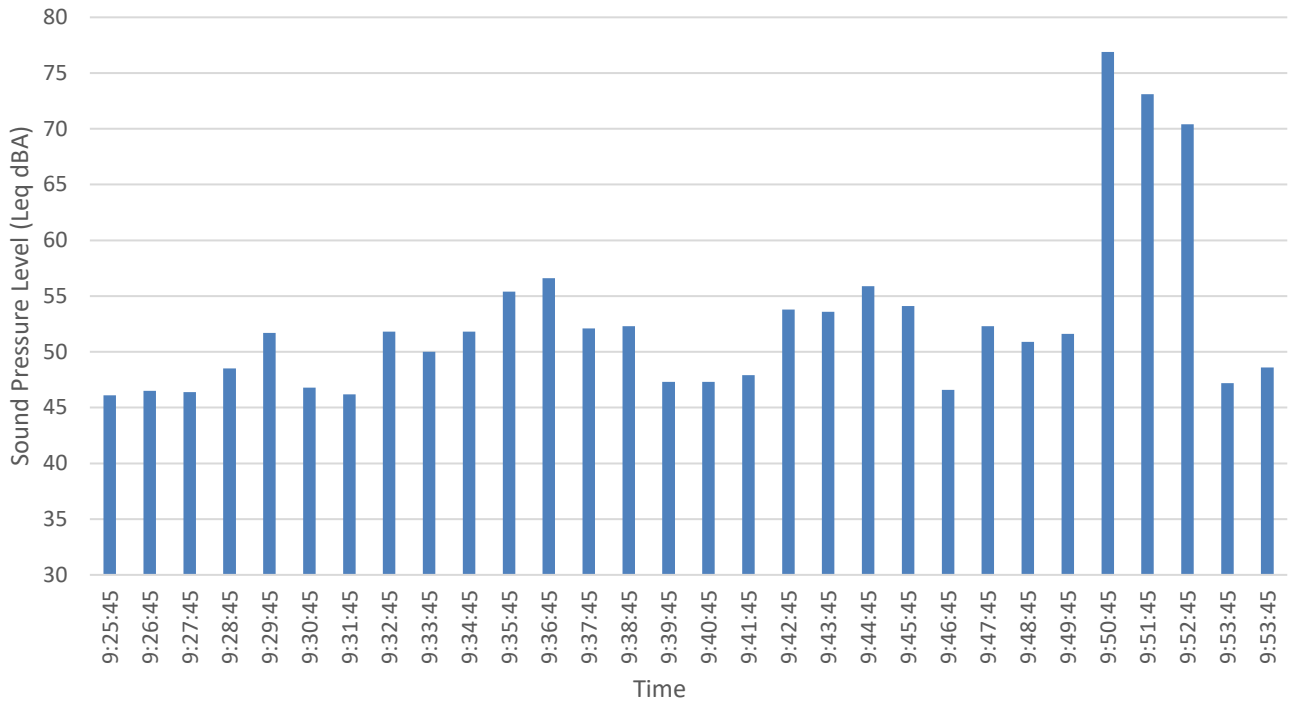
SUBSET Leq = 51.6 dBA

v = Other sources contributed to Leq X = Exclude period - contaminated by non-characteristic sources

>> ADD SKETCH AND WEATHER CONDITIONS TO REVERSE OR OTHER SHEET <<



Measured Sound Pressure Level ML-10





SHORT-TERM TRAFFIC NOISE MONITORING LOG SHEET

Reading: ML-16

Project Description: 10226441 - BMCD US380 Spur399 SCH ENV

Noise Source: Background Noise Date: Dec. 16, 2021 Personnel: RMB

Equipment	Type	Serial #
Sound Level Meter	Larson Davis	824A2636
Microphone/Preamp	Larson Davis 2541; PRM902	7490
Calibrator	Larson Davis CAL200	2618

SLM SETTINGS (circle one)

FAST

SLOW

WEIGHTING (circle one)

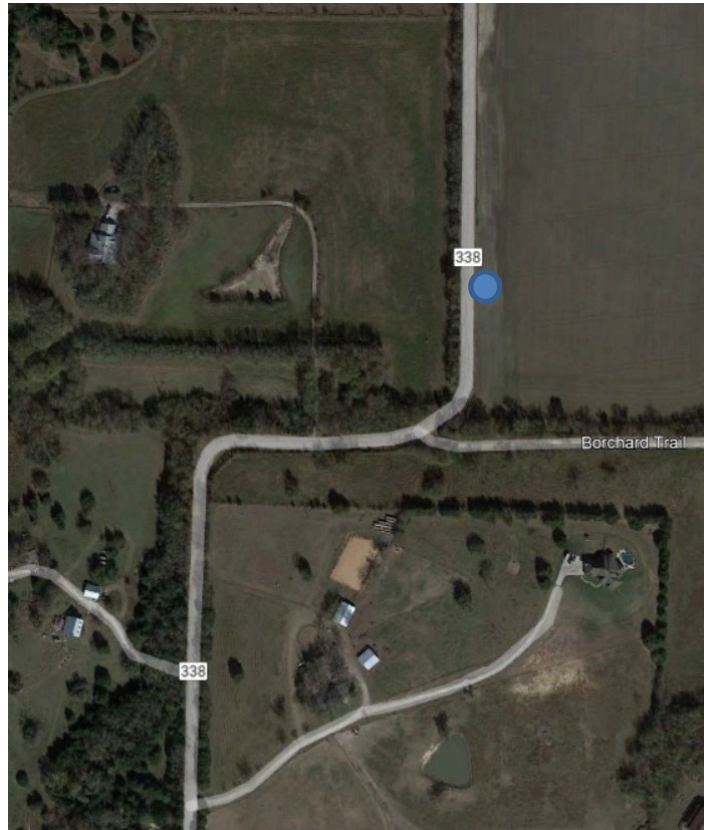
A

Lin.

Location Description: Location ML-16 – Background Noise

SITE SKETCH: Including noise source, receptors, reference distances, North arrow, wind direction arrow, terrain and shielding, roadway profile, and direct lines of sight:

SLM placed along TX 338. Meter paused for vehicle pass-bys. Typical noise sources included birds, small aircraft, distant traffic, and leaves. Typical ambient in 43-45 dBA range.





Start Time:

1:37:48 AM **PM**

Stop Time:

2:06:48 AM **PM**

Duration:

30 minutes

Wind Speed/Direction: 9 mph N

Percentiles: _____

Temperature: 63-70 F

Humidity: 46% RH (partly cloudy)

Calibration results before: _____ 114.0 dBA and after _____ 114.0 dBA

Traffic Count Roadway:

Autos	Medium Trucks	Heavy Trucks	Buses	Motorcycles

***Note roadway direction in table**



SHORT-TERM TRAFFIC NOISE MONITORING LOG SHEET

PROJECT: 10226441 - BMCD US380 Spur399 SCH ENV

JOB NO.: 10226441

SITE/READING NO.: File 17

PERSONNEL: RMB

LOCATION/ADDRESS: Location ML-16

DATE: 12/16/2021

#	1 Minute Period Starting	Meas'd Leq (dBA)	v or X	Other Noise Sources	COMMENTS
1	13:37:48	44.3			
2	13:38:48	44.2			Plane
3	13:39:48	44.7			
4	13:40:48	44.0			Plane
5	13:41:48	44.7			
6	13:42:48	47.1			
7	13:43:48	45.1			
8	13:44:48	42.8			
9	13:45:48	44.2			
10	13:46:48	46.6			Plane
11	13:47:48	49.3			Plane
12	13:48:48	45.1			
13	13:49:48	44.9			
14	13:50:48	44.7			
15	13:51:48	43.2			
16	13:52:48	43.6			
17	13:53:48	43.2			
18	13:54:48	42.9			
19	13:55:48	43.7			
20	13:56:48	65.4			Overhead plane
21	13:57:48	47.0			
22	13:58:48	45.8			Nearby plane / nearby car
23	13:59:48	46.3			
24	14:00:48	51.5			
25	14:01:48	42.1			
26	14:02:48	41.2			
27	14:03:48	43.6			
28	14:04:48	42.2			
29	14:05:48	59.1			Overhead jet
30	14:06:48	45.1			

TOTAL Leq = 52.4 dBA

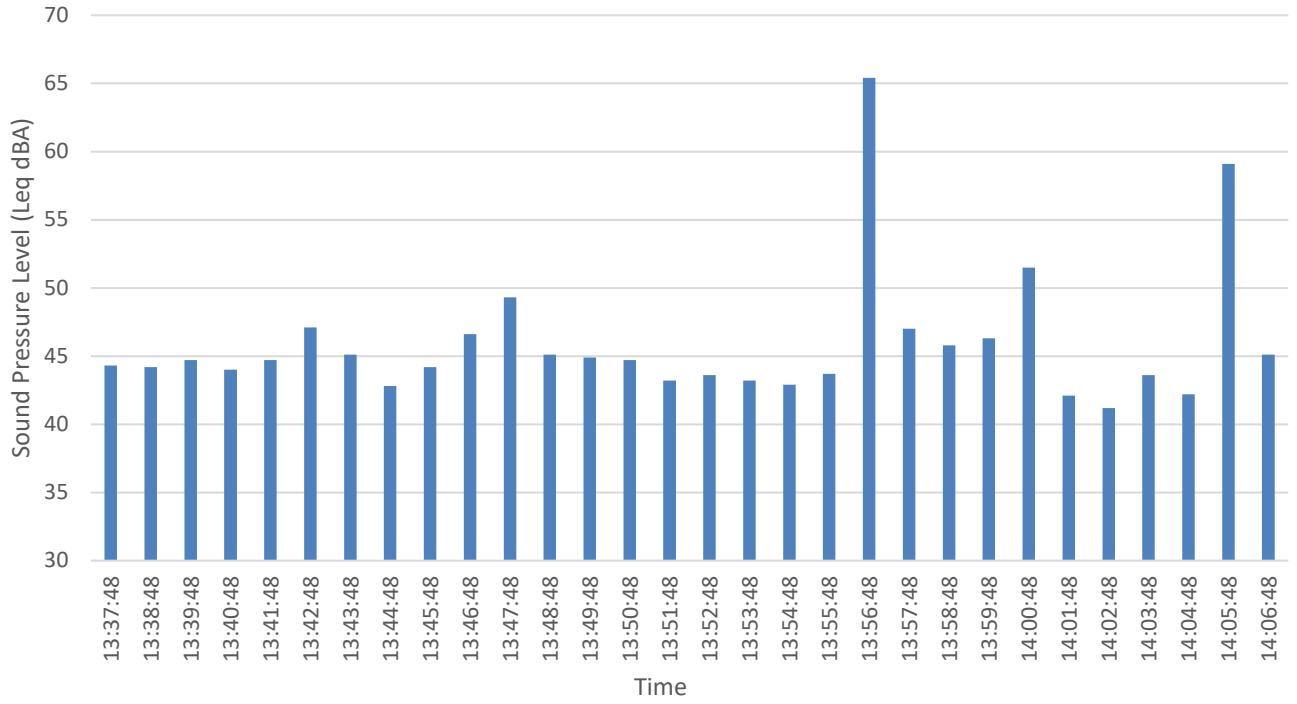
SUBSET Leq =

v = Other sources contributed to Leq X = Exclude period - contaminated by non-characteristic sources

>> ADD SKETCH AND WEATHER CONDITIONS TO REVERSE OR OTHER SHEET <<



Measured Sound Pressure Level ML-16



Appendix R-2: Traffic Noise Analysis Technical Report, November 2022



Traffic Noise Analysis Report

US 380 McKinney
Coit Road to FM 1827, Collin County
CSJ 0135-02-065, 0135-03-053, and 0135-15-002

Texas Department of Transportation
Dallas District

November 2022

The environmental review, consultation, and other actions required by applicable Federal environmental laws for this project are being, or have been, carried-out by TxDOT pursuant to 23 U.S.C. 327 and a Memorandum of Understanding dated December 9, 2019, and executed by FHWA and TxDOT.

TxDOT Environmental Affairs Division
730.06.TEM

Table of Contents

Introduction..... 3
Impact Analysis 5
Abatement Analysis 5
Validation..... 6
Segment A..... 7
Results..... 7
Abatement Analysis..... 24
Feasible and Reasonable Barriers 25
Segment B..... 26
Results..... 27
Abatement Analysis..... 36
Feasible and Reasonable Barriers 36
Segment C 39
Results..... 39
Abatement Analysis..... 43
Segment D 43
Results..... 43
Abatement Analysis..... 45
Segment E..... 46
Results..... 46
Abatement Analysis..... 59
Feasible and Reasonable Barriers 60
Statement of Likelihood..... 62
Noise Contours for Land Use Planning..... 62
Construction Noise 63
Local Official Notification and Date of Public Knowledge Statement..... 63
List of Attachments..... 64

List of Figures

Figure 1. Project Overview Map..... 3

List of Tables

Table 1. FHWA Noise Abatement Criteria (NAC) 4
Table 2. Summary of Traffic Noise Impacts for Segment A..... 7

Traffic Noise Analysis Report

Table 3. Segment A Traffic Noise Levels dB(A) Leq 7

Table 4. Segment A Proposed Noise Barriers 25

Table 5. Summary of Traffic Noise Impacts for Segment B..... 27

Table 6. Segment B Traffic Noise Levels dB(A) Leq 27

Table 7: Segment B Proposed Noise Barriers 37

Table 8. Summary of Traffic Noise Impacts for Segment C 39

Table 9. Segment C Traffic Noise Levels dB(A) Leq 40

Table 10. Summary of Traffic Noise Impacts for Segment D 43

Table 11. Segment D Traffic Noise Levels dB(A) Leq 43

Table 12. Summary of Traffic Noise Impacts for Segment E..... 46

Table 13. Segment E Traffic Noise Levels dB(A) Leq 46

Table 14. Segment E Proposed Noise Barriers 60

Table 15. Summary of Build Alternatives 62

Table 16. Noise Contours for Land Use Planning 63

List of Attachments

- Attachment A – Map Figures
- Attachment B – Traffic Figures
- Attachment C – Existing Model Validation Study
- Attachment D - Ambient Noise Measurements

US 380 MCKINNEY

TxDOT proposes to upgrade US 380 to an eight-lane, access-controlled freeway with two-lane, one-way frontage roads on each side within an anticipated right-of-way width between 350 to 1,580 feet depending on location. Frontage roads may be eliminated, and the primary travel lanes may be depressed/lowered or elevated (on bridge/viaduct) to minimize impacts on sensitive resources. The freeway facility would also include ramps, direct connector roadways, frontage roads, and arterial roadways to support connectivity to the existing roadway network. Grade-separated interchanges would be constructed at major crossroads including US 75/SH 5 (multi-level interchange) and other major local connectors as determined needed and feasible.

The typical freeway section would consist of: four 12-foot-wide travel lanes in each direction, 12-foot-wide turn lanes, 10-foot-wide inside shoulders (4-foot-wide may be considered in some locations), and 10-foot-wide outside shoulders. Ramps would be 14 feet-wide with 2-foot-wide inside shoulders and 6-foot-wide outside shoulders, with curb & gutter. Bridges/overpasses along the main lanes would have a desirable vertical clearance of 18.5 feet (minimum of 16.5 feet); vertical clearance over railroads would be 23.5 feet. Ramps, direct connector roadways, frontage roads, and arterial roadway improvements would follow similar design criteria. Median barriers would be included. As design of the Preferred Alternative continues, when selected, refinements may be made to further minimize impacts by considering additional or longer bridges and bridge type, location of permanent/ temporary easements, compressing ROW width, locations of depressed/lowered roadway sections, and safety lighting/signage/ITS.

The US 380 McKinney project has been developed in 5 segments, described below, that combine to form the new location Build alternatives under consideration.

- Segment A follows existing US 380 from Coit Road to near the approximate alignment of future Ridge Road where it turns north and connects to existing Bloomdale Road.
- Segment B follows existing US 380 from Coit Road to west of N. Custer Road (FM 2478) where it turns northeast to intersect with N. Custer Road and East First Street, then continues northeast to connect to existing Bloomdale Road at the future extension of Ridge Road.
- Segment C begins at SH 5 extending in a southeasterly direction across the Dallas Area Transit (DART) rail line and the East Fork Trinity River, then shifts to a more southerly direction east of and parallel to the East Fork Trinity River to connect to existing US 380 near FM 1827.
- Segment D also begins at SH 5 extending in a southerly direction across the DART rail line and the East Fork Trinity River and continues in a southerly direction west of and parallel to the East Fork Trinity River connecting to US 380 near Airport Drive and follows existing US 380 to the east to FM 1827.
- Segment E extends roughly along the alignment of existing Bloomdale Road through north McKinney beginning at the proposed intersection of Ridge Road and Bloomdale Road on the west and SH 5 on the east. This segment includes a new interchange connection with US 75 and SH 5. Segment E is a common segment in all the new location Build alternatives.

These segments when linked end-to-end connecting the logical termini of Coit Road and FM 1827 result in the Purple, Blue, Brown, and Gold alternatives described below. An alternative to improve existing US 380 between Coit Road and FM 1827 is not being considered.

The **Purple Alternative** (Segments A+E+D) is approximately 15.8 miles long. The Purple Alternative begins at the intersection of Coit Road and US 380 in the Town of Prosper and travels around the north side of McKinney turning south near US 75 and SH 5 to extend along the west side of the East Fork Trinity River to connect back to existing US 380 and FM 1827. Grade separations or grade-separated interchanges would be considered at N. Custer Road (FM 2478), the alignment's departure from existing US 380 at future Ridge Road, County Road (CR) 124/Future Wilmeth Road, Future Bloomdale Road West, CR 161/Future Ridge Road (McKinney city limits/Collin County line), Lake Forest Drive/FM 1461, Future CR 1006, Bloomdale Road East, CR 164/Future Hardin Road (McKinney city limits), Community Avenue, US 75 (multi-level), SH 5, McIntyre Road (Future Wilmeth Road), and at its connection back to US 380 near Airport Drive west of FM 1827. Additional grade-separations and interchange locations may be studied in coordination with the City of McKinney.

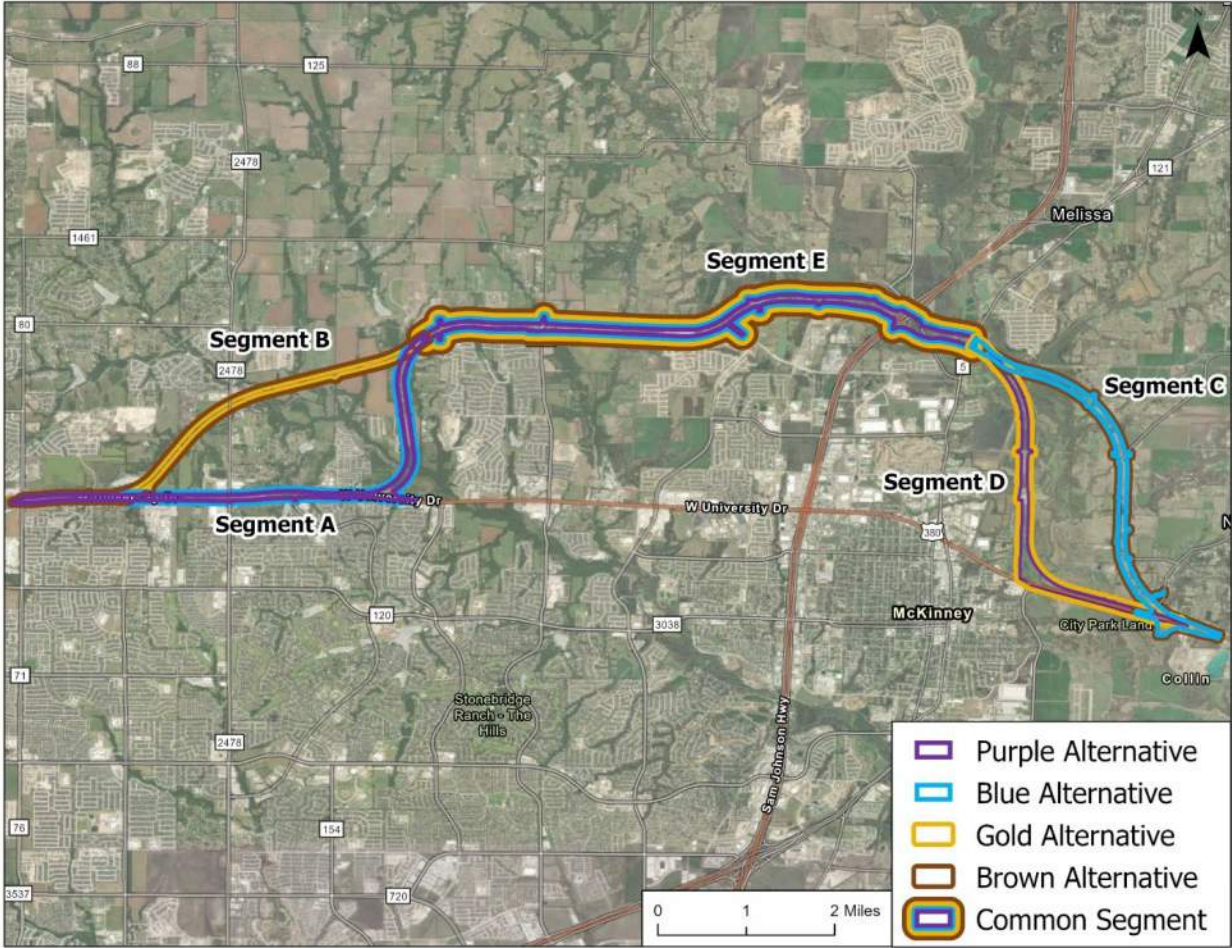
The **Blue Alternative** (Segments A+E+C) extends approximately 15.6 miles and differs from the Purple Alternative between US 75/SH 5 and existing US 380 east of McKinney where the alignment follows that of Segment C parallel to and east of the East Fork Trinity River. The alignment would connect back to existing US 380 near FM 1827. Grade separations or grade-separated interchanges would be considered at N. Custer Road, the alignment's departure from existing US 380 at future Ridge Road, County Road (CR) 124/Future Wilmeth Road, Future Bloomdale Road West, CR 161/Future Ridge Road, Lake Forest Drive/FM 1461, Future CR 1006, Bloomdale Road East, CR 164/Future Hardin Road, Community Avenue, US 75 (multi-level), SH 5, CR 338, and at its connection back to US 380 near FM 1827. Additional grade-separations and interchange locations may be studied in coordination with the City of McKinney.

The **Brown Alternative** (Segments B+E+C), approximately 14.8 miles long, begins at Coit Road and existing US 380 and follows the existing US 380 alignment to west of N. Custer Road where it turns north and east to travel around the north side of McKinney, connect to US 75/SH 5, and then follows the alignment east of and parallel to the East Fork Trinity River to connect to existing US 380 near FM 1827. The Brown Alternative differs from the Blue Alternative in the alignment from Coit Road to the future intersection of Ridge Road and Bloomdale Road (Segment B). Grade separations or grade-separated interchanges would be considered at US 380/Coit Road, Future Independence Parkway, N. Custer Road, Future North Stonebridge Drive, Future Bloomdale Road West, CR 161/Future Ridge Road, Lake Forest Drive/FM 1461, Future CR 1006, Bloomdale Road East, CR 164/Future Hardin Road, Community Avenue, US 75 (multi-level), SH 5, CR 338, and at its connection back to US 380 near FM 1827. Additional grade-separations and interchange locations may be studied in coordination with the City of McKinney.

The **Gold Alternative** (Segments B+E+D) is approximately 16.3 miles long and matches the Brown Alternative between Coit Road and US 75/SH 5 where it turns south along the west side of the East Fork Trinity River to connect to existing US 380 near Airport Drive and then follows the exiting US 380 alignment east to FM 1827. Grade separations or grade-separated interchanges would be considered at US 380/Coit Road, Future Independence Parkway, N. Custer Road, Future North Stonebridge Drive, Future Bloomdale Road West, CR 161/Future Ridge Road, Lake Forest Drive/FM 1461, Future CR 1006, Bloomdale Road East, CR 164/Future Hardin Road, Community Avenue, US 75 (multi-level), SH 5, McIntyre Road (Future Wilmeth Road), and at its connection back to US 380 near Airport Drive west of FM 1827. Additional grade-separations and interchange locations may be studied in coordination with the City of McKinney.

Figure 1 shows an overview map of the Project, delineating the segment alternatives.

Figure 1. Project Overview Map



Introduction

This analysis was accomplished in accordance with TxDOT’s (FHWA-approved) Traffic Noise Policy (2019).

Sound from highway traffic is generated primarily from a vehicle’s tires, engine and exhaust. It is commonly measured in decibels and is expressed as "dB."

Sound occurs over a wide range of frequencies. However, not all frequencies are equally detectable by the human ear; therefore, an adjustment is made to the high and low frequencies to approximate the way an average person hears traffic sounds. This adjustment is called A-weighting and is expressed as "dB(A)."

Also, because traffic sound levels are never constant due to the changing number, type and speed of vehicles, a single value is used to represent the average or equivalent sound level and is expressed as "Leq."

The traffic noise analysis typically includes the following elements:

- Identification of land use activity areas that might be impacted by traffic noise.
- Determination of existing noise levels.

Traffic Noise Analysis Report

- Prediction of future noise levels.
- Identification of possible noise impacts.
- Consideration and evaluation of measures to reduce noise impacts.

As shown in Table 1 below, the FHWA has established the following Noise Abatement Criteria (NAC) for various land use activity areas that are used as one of two means to determine when a traffic noise impact would occur.

Table 1. FHWA Noise Abatement Criteria (NAC)

Activity Category	FHWA (dB(A) Leq)	Description of Land Use Activity Areas
A	57 (exterior)	Lands on which serenity and quiet are of extra-ordinary significance and serve an important public need and where the preservation of those qualities is essential if the area is to continue to serve its intended purpose.
B	67 (exterior)	Residential
C	67 (exterior)	Active sport areas, amphitheatres, auditoriums, campgrounds, cemeteries, day care centers, hospitals, libraries, medical facilities, parks, picnic areas, places of worship, playgrounds, public meeting rooms, public or nonprofit institutional structures, radio studios, recording studios, recreation areas, Section 4(f) sites, schools, television studios, trails, and trail crossings
D	52 (interior)	Auditoriums, day care centers, hospitals, libraries, medical facilities, places of worship, public meeting rooms, public or nonprofit institutional structures, radio studios, recording studios, schools, and television studios
E	72 (exterior)	Hotels, motels, offices, restaurants/bars, and other developed lands, properties, or activities not included in A-D or F.
F	--	Agricultural, airports, bus yards, emergency services, industrial, logging, maintenance facilities, manufacturing, mining, rail yards, retail facilities, shipyards, utilities (water resources, water treatment, electrical), and warehousing.
G	--	Undeveloped lands that are not permitted.

Source: *Guidelines for Analysis and Abatement of Roadway Traffic Noise* (TxDOT 2019)

A noise impact occurs when either the absolute or relative criterion is met:

Absolute criterion - The predicted noise level at a receptor approaches, equals, or exceeds the NAC. "Approach" is defined as one dB(A) below the NAC. For example: a noise impact would occur at a Category B residence if the noise level is predicted to be 66 dB(A) or above.

Relative criterion - The predicted noise level substantially exceeds the existing noise level at a receptor even though the predicted noise level does not approach, equal or exceed the NAC. "Substantially exceeds" is defined as more than 10 dB(A). For example: a noise impact would occur at a Category B residence if the existing level is 54 dB(A) and the predicted level is 65 dB(A).

When a traffic noise impact occurs, noise abatement measures must be considered. A noise abatement measure is any positive action taken to reduce the impact of traffic noise on an activity area.

Impact Analysis

The FHWA traffic noise modeling software (TNM 2.5) was used to calculate existing and predicted traffic noise levels. The model primarily considers the number, type and speed of vehicles; highway alignment and grade; cuts, fills and natural berms; surrounding terrain features; and the locations of activity areas likely to be impacted by the associated traffic noise. Analysis for new location areas, such as for Segment C, D, and E, utilized existing ambient noise level measurements to establish a baseline reference for relative noise impact evaluation.

The traffic projections and traffic methodology were prepared by Kimley Horn, and reviewed by TTI for QA/QC. The Dallas District approved the traffic methodology and line diagrams. The line diagrams depict 2030, 2050, and 2060 anticipated average daily traffic and turning movements for the proposed corridor improvements. TPP then developed the noise, air and pavement data for this project.

The existing AM and PM peak-hour traffic volumes for the intersections and roadways in the environmental influence area were developed and obtained using the available sources listed below:

- Collected TMCs for the signalized intersections along US 380 and Spur 399
- TxDOT's Traffic Count Database System (TCDS) /Statewide Traffic Analysis and Reporting System (STARS II)
- Traffic data from City of McKinney Interactive Map website - [City of McKinney | Engineering and Transportation \(arcgis.com\)](https://www.mckinneytx.gov/Engineering-and-Transportation/arcgis.com)
- Historic Traffic Counts from North Central Texas Council of Governments (NCTCOG)
- StreetLight Data

TCDS, City of McKinney Interactive Map and NCTCOG website provided historic daily traffic volume information for the available roadways. To calculate the AM and PM peak hour volumes, K-factor and D values was taken into consideration. These values can be obtained from available points in TCDS and estimated based on the available data. StreetLight data was utilized to calculate the turning movement traffic proportions at the intersections and estimate the volumes for the roadways without any traffic information from other sources. The traffic volumes obtained for the study corridor based on the above methodology was utilized to perform noise analysis.

The approved traffic data used in this analysis is included in **Attachment B**.

As of April 22, 2022, Category B, C, and E receptors include permitted new development for the Town of Prosper and the City of McKinney. Development permits issued after April 22, 2022, were not included in the analysis.

Results are separated by individual segment (Segment A-E) in subsequent report sections.

Abatement Analysis

Before any abatement measure can be proposed for incorporation into the project, it must be both feasible and reasonable. Feasibility and reasonableness considerations include constructability, the predicted acoustic

reductions provided by an abatement measure, a cost allowance, and whether the adjacent receptors desire abatement. Receptors associated with an abatement measure that achieve a noise reduction of five dB(A) or greater are called benefited receptors.

In order to be "feasible," the abatement measure must benefit a minimum of two impacted receptors AND reduce the predicted noise level by at least five dB(A) at greater than 50 percent of first-row impacted receptors. Engineering considerations, such as access, drainage and utility locations, are also factored in the feasibility assessment of a potential noise barrier.

In order to be "reasonable," the abatement measure must also reduce the predicted noise level by at least seven dB(A) for at least one benefited receptor (noise reduction design goal) and not exceed the standard barrier cost of 1,500 square feet per benefited receptor. In addition, an abatement measure may not be reasonable if the construction costs are unreasonably high due to site constraints, as determined through an alternate barrier cost assessment.

The following noise abatement measures were considered: traffic management, alteration of horizontal and/or vertical alignments, acquisition of undeveloped property to act as a buffer zone, and the construction of noise barriers.

Traffic management – Control devices could be used to reduce the speed of the traffic; however, the minor benefit of one dB(A) per five mph reduction in speed does not outweigh the associated increase in congestion and air pollution. Other measures such as time or use restrictions for certain vehicles are prohibited on state highways.

Alteration of horizontal and/or vertical alignments – Any alteration of the existing alignment would displace existing businesses and residences, require additional right of way and not be cost effective/reasonable.

Buffer zone – The acquisition of undeveloped property to act as a buffer zone is designed to avoid rather than abate traffic noise impacts and, therefore, is not feasible.

Noise barriers – Noise barriers in the form of noise walls are the most commonly used noise abatement measures and were considered for this project. Noise barriers were evaluated for each of the impacted receptor locations. The heights of evaluated noise barriers are included in applicable tables, with no barrier exceeding 20 ft in height. For abatement scenarios that feature multiple noise barrier location options, for example at ROW or edge-of-pavement positions, noise barrier naming conventions include a dash ("-") for denoting such alternatives.

Abatement analysis results discussing noise barrier feasibility and reasonableness are separated by individual segment (Segment A-E) in subsequent report sections.

Validation

A validation study was performed in order to ensure that traffic noise is the main source of noise and to verify that the existing model accurately predicts existing traffic noise based on current conditions. Model validation compares field-collected sound level measurements to traffic noise levels calculated in an existing condition model that used field-collected traffic parameters. Differences between the measured and calculated levels for this project were within the +/- 3 dB(A) tolerance allowed by FHWA. Therefore, the existing noise model is considered validated for this project. Additional information on the validation study is included in **Attachment C**.

Segment A

Segment A serves as a portion of the Purple and Blue alternatives. Segment A follows existing US 380 from Coit Road to near the approximate alignment of future Ridge Road where it turns north and connects to Bloomdale Road.

Results

Table 2 provides a summary of the traffic noise impacts for Segment A according to evaluated land-use receptors.

Table 2. Summary of Traffic Noise Impacts for Segment A

NAC	RECEPTORS	IMPACTS
A	0	0
B	487	108
C	55	9
D	0	0
E	0	0
TOTAL	542	117

Existing and predicted traffic noise levels for Segment A were modeled at receiver locations listed in Table 3 that represent the land use activity areas adjacent to the proposed project that might be impacted by traffic noise and potentially benefit from feasible and reasonable noise abatement.

Table 3. Segment A Traffic Noise Levels dB(A) Leq

Segment A Representative Receiver	Figure	NAC Category	NAC Level	Existing	Predicted 2050	Change (+/-)	Noise Impact (Yes/No)
R-1	Figure A-1	B-Residential	67	60	63	3	No
R-3	Figure A-1	B-Residential	67	60	63	3	No
R-5	Figure A-1	B-Residential	67	60	63	3	No
R-7	Figure A-1	B-Residential	67	62	65	3	No
R-9	Figure A-1	B-Residential	67	55	59	4	No
R-11	Figure A-1	B-Residential	67	61	64	3	No
R-13	Figure A-1	B-Residential	67	61	65	4	No
R-15	Figure A-1	B-Residential	67	56	59	3	No
R-17	Figure A-1	B-Residential	67	61	65	4	No
R-19	Figure A-1	B-Residential	67	63	66	3	Yes
R-21	Figure A-1	B-Residential	67	56	60	4	No
R-23	Figure A-1	B-Residential	67	63	67	4	Yes
R-25	Figure A-1	B-Residential	67	61	65	4	No
R-27	Figure A-1	B-Residential	67	57	61	4	No
R-29	Figure A-1	B-Residential	67	63	68	5	Yes
R-31	Figure A-1	B-Residential	67	61	66	5	Yes

Traffic Noise Analysis Report

Table 3. Segment A Traffic Noise Levels dB(A) Leq

Segment A Representative Receiver	Figure	NAC Category	NAC Level	Existing	Predicted 2050	Change (+/-)	Noise Impact (Yes/No)
R-33	Figure A-1	B-Residential	67	59	62	3	No
R-35	Figure A-1	B-Residential	67	61	66	5	Yes
R-37	Figure A-1	B-Residential	67	64	68	4	Yes
R-39	Figure A-1	B-Residential	67	61	65	4	No
R-41	Figure A-1	B-Residential	67	62	66	4	Yes
R-43	Figure A-1	B-Residential	67	62	66	4	Yes
R-45	Figure A-1	B-Residential	67	64	68	4	Yes
R-47	Figure A-1	B-Residential	67	62	66	4	Yes
R-49	Figure A-1	B-Residential	67	65	69	4	Yes
R-51	Figure A-1	B-Residential	67	68	72	4	Yes
R-53	Figure A-1	B-Residential	67	62	66	4	Yes
R-55	Figure A-1	B-Residential	67	60	64	4	No
R-57	Figure A-1	B-Residential	67	61	65	4	No
R-59	Figure A-1	B-Residential	67	64	68	4	Yes
R-61	Figure A-1	B-Residential	67	68	73	5	Yes
R-63	Figure A-1	B-Residential	67	63	68	5	Yes
R-65	Figure A-1	B-Residential	67	61	65	4	No
R-67	Figure A-1	B-Residential	67	62	66	4	Yes
R-69	Figure A-1	B-Residential	67	60	64	4	No
R-71	Figure A-1	B-Residential	67	68	72	4	Yes
R-73	Figure A-1	B-Residential	67	65	68	3	Yes
R-75	Figure A-1	B-Residential	67	65	68	3	Yes
R-77	Figure A-2	B-Residential	67	64	67	3	Yes
R-79	Figure A-2	B-Residential	67	63	66	3	Yes
R-81	Figure A-2	B-Residential	67	61	64	3	No
R-83	Figure A-2	B-Residential	67	60	63	3	No
R-85	Figure A-2	B-Residential	67	62	65	3	No
R-87	Figure A-2	B-Residential	67	62	65	3	No
R-89	Figure A-2	B-Residential	67	64	67	3	Yes
R-91	Figure A-2	B-Residential	67	62	65	3	No
R-93	Figure A-2	B-Residential	67	63	66	3	Yes
R-95	Figure A-2	B-Residential	67	58	61	3	No
R-97	Figure A-2	B-Residential	67	59	62	3	No
R-99	Figure A-2	B-Residential	67	59	62	3	No
R-101	Figure A-2	B-Residential	67	62	65	3	No
R-103	Figure A-2	B-Residential	67	58	61	3	No
R-105	Figure A-2	B-Residential	67	62	65	3	No
R-107	Figure A-2	B-Residential	67	65	68	3	Yes
R-109	Figure A-2	B-Residential	67	64	67	3	Yes

Traffic Noise Analysis Report

Table 3. Segment A Traffic Noise Levels dB(A) Leq

Segment A Representative Receiver	Figure	NAC Category	NAC Level	Existing	Predicted 2050	Change (+/-)	Noise Impact (Yes/No)
R-111	Figure A-2	B-Residential	67	61	64	3	No
R-113	Figure A-2	B-Residential	67	62	65	3	No
R-115	Figure A-2	B-Residential	67	60	64	4	No
R-117	Figure A-2	B-Residential	67	59	62	3	No
R-119	Figure A-2	B-Residential	67	60	63	3	No
R-121	Figure A-2	B-Residential	67	58	62	4	No
R-123	Figure A-2	B-Residential	67	59	63	4	No
R-125	Figure A-2	B-Residential	67	63	66	3	Yes
R-127	Figure A-2	B-Residential	67	68	69	1	Yes
R-129	Figure A-2	B-Residential	67	59	63	4	No
R-131	Figure A-2	B-Residential	67	67	69	2	Yes
R-133	Figure A-2	B-Residential	67	59	63	4	No
R-135	Figure A-2	B-Residential	67	70	71	1	Yes
R-137	Figure A-2	B-Residential	67	60	64	4	No
R-139	Figure A-2	B-Residential	67	66	69	3	Yes
R-141	Figure A-2	B-Residential	67	59	64	5	No
R-143	Figure A-2	B-Residential	67	59	63	4	No
R-145	Figure A-2	B-Residential	67	59	64	5	No
R-147	Figure A-2	B-Residential	67	68	71	3	Yes
R-149	Figure A-2	B-Residential	67	59	64	5	No
R-151	Figure A-2	B-Residential	67	57	63	6	No
R-153	Figure A-2	B-Residential	67	61	67	6	Yes
R-155	Figure A-2	B-Residential	67	59	65	6	No
R-157	Figure A-2	B-Residential	67	67	72	5	Yes
R-159	Figure A-2	B-Residential	67	63	69	6	Yes
R-161	Figure A-2	B-Residential	67	63	68	5	Yes
R-172	Figure A-3	B-Residential	67	59	62	3	No
R-173	Figure A-3	B-Residential	67	56	61	5	No
R-174	Figure A-3	B-Residential	67	56	61	5	No
R-175	Figure A-3	B-Residential	67	57	61	4	No
R-176	Figure A-3	B-Residential	67	55	60	5	No
R-177	Figure A-3	B-Residential	67	59	63	4	No
R-178	Figure A-3	B-Residential	67	59	63	4	No
R-180	Figure A-3	B-Residential	67	59	63	4	No
R-182	Figure A-3	B-Residential	67	59	63	4	No
R-183	Figure A-3	B-Residential	67	57	61	4	No
R-187	Figure A-3	B-Residential	67	59	63	4	No
R-188	Figure A-3	B-Residential	67	57	61	4	No
R-191	Figure A-3	B-Residential	67	59	63	4	No

Traffic Noise Analysis Report

Table 3. Segment A Traffic Noise Levels dB(A) Leq

Segment A Representative Receiver	Figure	NAC Category	NAC Level	Existing	Predicted 2050	Change (+/-)	Noise Impact (Yes/No)
R-193	Figure A-3	B-Residential	67	57	61	4	No
R-195	Figure A-3	B-Residential	67	59	63	4	No
R-196	Figure A-3	B-Residential	67	57	61	4	No
R-198	Figure A-3	B-Residential	67	57	61	4	No
R-200	Figure A-3	B-Residential	67	59	63	4	No
R-201	Figure A-3	B-Residential	67	57	61	4	No
R-202	Figure A-3	B-Residential	67	59	63	4	No
R-206	Figure A-3	B-Residential	67	59	64	5	No
R-207	Figure A-3	B-Residential	67	57	62	5	No
R-208	Figure A-3	B-Residential	67	59	64	5	No
R-209	Figure A-3	B-Residential	67	57	62	5	No
R-211	Figure A-3	B-Residential	67	59	64	5	No
R-212	Figure A-3	B-Residential	67	57	62	5	No
R-217	Figure A-3	B-Residential	67	57	62	5	No
R-219	Figure A-3	C-Pool	67	58	64	6	No
R-220	Figure A-3	B-Residential	67	57	62	5	No
R-222	Figure A-3	B-Residential	67	57	62	5	No
R-225	Figure A-3	B-Residential	67	59	64	5	No
R-226	Figure A-3	B-Residential	67	57	62	5	No
R-229	Figure A-3	B-Residential	67	57	62	5	No
R-231	Figure A-3	B-Residential	67	59	64	5	No
R-232	Figure A-3	B-Residential	67	57	62	5	No
R-237	Figure A-3	B-Residential	67	59	65	6	No
R-241	Figure A-3	B-Residential	67	59	65	6	No
R-242	Figure A-3	B-Residential	67	55	61	6	No
R-243	Figure A-3	B-Residential	67	59	64	5	No
R-244	Figure A-3	B-Residential	67	56	61	5	No
R-245	Figure A-3	B-Residential	67	56	62	6	No
R-246	Figure A-3	B-Residential	67	57	63	6	No
R-455	Figure A-4	B-Residential	67	57	64	7	No
R-458	Figure A-4	B-Residential	67	56	61	5	No
R-461	Figure A-4	B-Residential	67	56	62	6	No
R-462	Figure A-4	B-Residential	67	55	61	6	No
R-465	Figure A-5	B-Residential	67	54	62	8	No
R-466	Figure A-5	B-Residential	67	58	67	9	Yes
R-467	Figure A-5	B-Residential	67	52	60	8	No
R-468	Figure A-5	B-Residential	67	54	63	9	No
R-469	Figure A-6	C-Park Bench	67	50	55	5	No
R-470	Figure A-6	C-Park Bench	67	50	55	5	No

Traffic Noise Analysis Report

Table 3. Segment A Traffic Noise Levels dB(A) Leq

Segment A Representative Receiver	Figure	NAC Category	NAC Level	Existing	Predicted 2050	Change (+/-)	Noise Impact (Yes/No)
R-471	Figure A-6	C-Public and Private Parks/Open Spaces	67	53	59	6	No
R-472	Figure A-6	C-Picnic areas	67	53	59	6	No
R-473	Figure A-6	C-Picnic areas	67	53	59	6	No
R-474	Figure A-6	C-Public and Private Parks/Open Spaces	67	60	66	6	Yes
R-475	Figure A-6	C-Picnic areas	67	57	63	6	No
R-476	Figure A-6	C-Picnic areas	67	57	63	6	No
R-477	Figure A-5	C-Public and Private Parks/Open Spaces	67	69	72	3	Yes
R-478	Figure A-6	B-Residential	67	56	63	7	No
R-479	Figure A-6	B-Residential	67	57	63	6	No
R-480	Figure A-6	B-Residential	67	56	62	6	No
R-481	Figure A-6	B-Residential	67	55	62	7	No
R-482	Figure A-6	B-Residential	67	54	61	7	No
R-483	Figure A-5	B-Residential	67	59	65	6	No
R-484	Figure A-6	B-Residential	67	54	60	6	No
R-485	Figure A-5	B-Residential	67	60	64	4	No
R-486	Figure A-6	B-Residential	67	53	60	7	No
R-487	Figure A-6	B-Residential	67	56	62	6	No
R-488	Figure A-6	B-Residential	67	55	61	6	No
R-489	Figure A-5	B-Residential	67	59	65	6	No
R-490	Figure A-6	B-Residential	67	56	62	6	No
R-491	Figure A-6	B-Residential	67	54	60	6	No
R-492	Figure A-5	B-Residential	67	59	64	5	No
R-493	Figure A-6	B-Residential	67	53	59	6	No
R-494	Figure A-6	B-Residential	67	56	62	6	No
R-495	Figure A-6	B-Residential	67	54	60	6	No
R-496	Figure A-5	B-Residential	67	59	64	5	No
R-497	Figure A-6	B-Residential	67	56	61	5	No
R-498	Figure A-5	B-Residential	67	58	63	5	No
R-499	Figure A-6	B-Residential	67	54	60	6	No
R-500	Figure A-6	B-Residential	67	53	59	6	No
R-501	Figure A-6	B-Residential	67	56	61	5	No
R-502	Figure A-5	B-Residential	67	58	63	5	No
R-503	Figure A-6	B-Residential	67	55	60	5	No
R-504	Figure A-6	B-Residential	67	53	58	5	No
R-505	Figure A-6	B-Residential	67	56	61	5	No

Traffic Noise Analysis Report

Table 3. Segment A Traffic Noise Levels dB(A) Leq

Segment A Representative Receiver	Figure	NAC Category	NAC Level	Existing	Predicted 2050	Change (+/-)	Noise Impact (Yes/No)
R-506	Figure A-6	B-Residential	67	55	60	5	No
R-507	Figure A-5	B-Residential	67	58	63	5	No
R-508	Figure A-6	B-Residential	67	53	58	5	No
R-509	Figure A-6	B-Residential	67	56	61	5	No
R-510	Figure A-6	B-Residential	67	55	60	5	No
R-511	Figure A-5	B-Residential	67	58	62	4	No
R-512	Figure A-6	B-Residential	67	53	58	5	No
R-513	Figure A-6	B-Residential	67	56	60	4	No
R-514	Figure A-6	B-Residential	67	55	59	4	No
R-515	Figure A-5	B-Residential	67	59	63	4	No
R-516	Figure A-5	B-Residential	67	60	68	8	Yes
R-517	Figure A-6	B-Residential	67	53	58	5	No
R-518	Figure A-6	B-Residential	67	56	60	4	No
R-519	Figure A-6	B-Residential	67	55	59	4	No
R-520	Figure A-5	B-Residential	67	59	63	4	No
R-521	Figure A-6	B-Residential	67	57	59	2	No
R-522	Figure A-6	B-Residential	67	55	58	3	No
R-523	Figure A-6	B-Residential	67	53	58	5	No
R-524	Figure A-5	B-Residential	67	59	63	4	No
R-525	Figure A-6	B-Residential	67	57	59	2	No
R-526	Figure A-5	B-Residential	67	60	63	3	No
R-527	Figure A-6	B-Residential	67	55	58	3	No
R-528	Figure A-6	B-Residential	67	53	57	4	No
R-529	Figure A-6	B-Residential	67	56	57	1	No
R-530	Figure A-6	B-Residential	67	54	56	2	No
R-531	Figure A-5	B-Residential	67	60	63	3	No
R-532	Figure A-5	B-Residential	67	60	62	2	No
R-533	Figure A-5	B-Residential	67	59	58	-1	No
R-534	Figure A-6	B-Residential	67	57	59	2	No
R-535	Figure A-6	B-Residential	67	56	58	2	No
R-536	Figure A-6	B-Residential	67	58	59	1	No
R-537	Figure A-6	B-Residential	67	55	58	3	No
R-538	Figure A-6	B-Residential	67	59	58	-1	No
R-539	Figure A-5	B-Residential	67	57	61	4	No
R-540	Figure A-6	B-Residential	67	59	58	-1	No
R-541	Figure A-6	B-Residential	67	59	59	0	No
R-542	Figure A-6	B-Residential	67	58	59	1	No
R-543	Figure A-5	B-Residential	67	58	62	4	No
R-544	Figure A-6	B-Residential	67	55	58	3	No

Traffic Noise Analysis Report

Table 3. Segment A Traffic Noise Levels dB(A) Leq

Segment A Representative Receiver	Figure	NAC Category	NAC Level	Existing	Predicted 2050	Change (+/-)	Noise Impact (Yes/No)
R-545	Figure A-6	B-Residential	67	57	59	2	No
R-546	Figure A-6	B-Residential	67	56	58	2	No
R-547	Figure A-5	B-Residential	67	60	59	-1	No
R-548	Figure A-5	B-Residential	67	59	63	4	No
R-549	Figure A-5	B-Residential	67	60	64	4	No
R-550	Figure A-5	B-Residential	67	60	65	5	No
R-551	Figure A-5	B-Residential	67	61	66	5	Yes
R-552	Figure A-7	B-Residential	67	62	66	4	Yes
R-553	Figure A-7	B-Residential	67	61	65	4	No
R-554	Figure A-7	B-Residential	67	63	67	4	Yes
R-555	Figure A-7	B-Residential	67	55	57	2	No
R-556	Figure A-7	B-Residential	67	56	57	1	No
R-557	Figure A-7	B-Residential	67	57	58	1	No
R-558	Figure A-7	B-Residential	67	57	59	2	No
R-559	Figure A-7	B-Residential	67	63	68	5	Yes
R-560	Figure A-7	B-Residential	67	61	64	3	No
R-561	Figure A-7	B-Residential	67	62	65	3	No
R-562	Figure A-7	B-Residential	67	64	69	5	Yes
R-563	Figure A-7	B-Residential	67	62	65	3	No
R-564	Figure A-7	B-Residential	67	60	62	2	No
R-565	Figure A-7	B-Residential	67	59	61	2	No
R-566	Figure A-7	B-Residential	67	58	61	3	No
R-567	Figure A-7	B-Residential	67	57	59	2	No
R-568	Figure A-7	B-Residential	67	64	69	5	Yes
R-569	Figure A-7	B-Residential	67	56	58	2	No
R-570	Figure A-7	B-Residential	67	55	57	2	No
R-571	Figure A-7	B-Residential	67	55	57	2	No
R-572	Figure A-7	B-Residential	67	62	66	4	Yes
R-573	Figure A-7	B-Residential	67	62	66	4	Yes
R-574	Figure A-7	B-Residential	67	59	61	2	No
R-575	Figure A-7	B-Residential	67	62	68	6	Yes
R-576	Figure A-7	B-Residential	67	62	65	3	No
R-577	Figure A-7	B-Residential	67	59	61	2	No
R-578	Figure A-7	B-Residential	67	60	64	4	No
R-579	Figure A-7	B-Residential	67	59	61	2	No
R-580	Figure A-7	B-Residential	67	54	58	4	No
R-581	Figure A-7	B-Residential	67	59	63	4	No
R-582	Figure A-7	B-Residential	67	60	63	3	No
R-583	Figure A-7	B-Residential	67	59	62	3	No

Traffic Noise Analysis Report

Table 3. Segment A Traffic Noise Levels dB(A) Leq

Segment A Representative Receiver	Figure	NAC Category	NAC Level	Existing	Predicted 2050	Change (+/-)	Noise Impact (Yes/No)
R-584	Figure A-7	B-Residential	67	55	58	3	No
R-585	Figure A-7	B-Residential	67	57	60	3	No
R-586	Figure A-7	B-Residential	67	59	63	4	No
R-587	Figure A-7	B-Residential	67	56	59	3	No
R-588	Figure A-7	B-Residential	67	60	64	4	No
R-589	Figure A-7	B-Residential	67	59	62	3	No
R-590	Figure A-7	B-Residential	67	59	61	2	No
R-591	Figure A-7	B-Residential	67	55	58	3	No
R-592	Figure A-7	B-Residential	67	53	56	3	No
R-593	Figure A-7	B-Residential	67	59	61	2	No
R-594	Figure A-7	B-Residential	67	58	62	4	No
R-595	Figure A-7	B-Residential	67	56	59	3	No
R-596	Figure A-7	B-Residential	67	58	60	2	No
R-597	Figure A-7	B-Residential	67	59	62	3	No
R-598	Figure A-7	B-Residential	67	58	61	3	No
R-599	Figure A-7	B-Residential	67	59	62	3	No
R-600	Figure A-7	B-Residential	67	57	59	2	No
R-601	Figure A-7	B-Residential	67	59	63	4	No
R-602	Figure A-7	B-Residential	67	56	58	2	No
R-603	Figure A-7	B-Residential	67	57	58	1	No
R-604	Figure A-7	B-Residential	67	59	63	4	No
R-605	Figure A-7	B-Residential	67	55	56	1	No
R-606	Figure A-7	B-Residential	67	53	55	2	No
R-607	Figure A-7	B-Residential	67	57	56	-1	No
R-608	Figure A-7	B-Residential	67	58	63	5	No
R-609	Figure A-7	B-Residential	67	55	55	0	No
R-610	Figure A-7	B-Residential	67	59	65	6	No
R-611	Figure A-7	B-Residential	67	62	69	7	Yes
R-612	Figure A-7	B-Residential	67	58	62	4	No
R-613	Figure A-7	B-Residential	67	57	59	2	No
R-614	Figure A-7	B-Residential	67	56	57	1	No
R-615	Figure A-7	B-Residential	67	55	56	1	No
R-616	Figure A-7	B-Residential	67	59	64	5	No
R-617	Figure A-7	C- School/ Preschool	67	54	56	2	No
R-618	Figure A-7	C-Pool	67	57	59	2	No
R-619	Figure A-7	C- School/ Preschool	67	56	58	2	No
R-620	Figure A-7	C- School/ Preschool	67	59	59	0	No

Traffic Noise Analysis Report

Table 3. Segment A Traffic Noise Levels dB(A) Leq

Segment A Representative Receiver	Figure	NAC Category	NAC Level	Existing	Predicted 2050	Change (+/-)	Noise Impact (Yes/No)
R-621	Figure A-7	C- School/Preschool	67	58	58	0	No
R-622	Figure A-8	B-Residential Apartment Floor 1	67	57	61	4	No
R-623	Figure A-8	B-Residential Apartment Floor 2	67	60	63	3	No
R-624	Figure A-8	B-Residential Apartment Floor 1	67	59	63	4	No
R-625	Figure A-8	B-Residential Apartment Floor 2	67	62	65	3	No
R-626	Figure A-8	B-Residential Apartment Floor 1	67	57	62	5	No
R-627	Figure A-8	B-Residential Apartment Floor 2	67	60	63	3	No
R-628	Figure A-8	B-Residential Apartment Floor 1	67	58	62	4	No
R-629	Figure A-8	B-Residential Apartment Floor 2	67	61	64	3	No
R-630	Figure A-8	B-Residential Apartment Floor 1	67	58	62	4	No
R-631	Figure A-8	B-Residential Apartment Floor 2	67	61	64	3	No
R-632	Figure A-8	B-Residential Apartment Floor 1	67	59	63	4	No
R-633	Figure A-8	B-Residential Apartment Floor 2	67	62	64	2	No
R-634	Figure A-8	B-Residential Apartment Floor 1	67	56	61	5	No
R-635	Figure A-8	B-Residential Apartment Floor 2	67	60	63	3	No
R-636	Figure A-8	B-Residential Apartment Floor 1	67	57	62	5	No
R-637	Figure A-8	B-Residential Apartment Floor 2	67	60	63	3	No
R-638	Figure A-8	B-Residential Apartment Floor 1	67	66	67	1	Yes
R-639	Figure A-8	B-Residential Apartment Floor 2	67	69	71	2	Yes
R-640	Figure A-8	B-Residential Apartment Floor 1	67	64	66	2	Yes
R-641	Figure A-8	B-Residential Apartment Floor 2	67	67	69	2	Yes
R-642	Figure A-8	B-Residential Apartment Floor 1	67	64	66	2	Yes
R-643	Figure A-8	B-Residential Apartment Floor 2	67	67	69	2	Yes
R-644	Figure A-8	B-Residential Apartment Floor 1	67	67	67	0	Yes
R-645	Figure A-8	B-Residential Apartment Floor 2	67	69	71	2	Yes

Traffic Noise Analysis Report

Table 3. Segment A Traffic Noise Levels dB(A) Leq

Segment A Representative Receiver	Figure	NAC Category	NAC Level	Existing	Predicted 2050	Change (+/-)	Noise Impact (Yes/No)
R-646	Figure A-8	B-Residential Apartment Floor 1	67	67	67	0	Yes
R-647	Figure A-8	B-Residential Apartment Floor 2	67	69	71	2	Yes
R-648	Figure A-8	B-Residential Apartment Floor 1	67	65	66	1	Yes
R-649	Figure A-8	B-Residential Apartment Floor 2	67	68	69	1	Yes
R-650	Figure A-8	B-Residential Apartment Floor 1	67	59	63	4	No
R-651	Figure A-8	B-Residential Apartment Floor 2	67	63	64	1	No
R-652	Figure A-8	B-Residential Apartment Floor 3	67	64	66	2	Yes
R-653	Figure A-8	B-Residential Apartment Floor 3	67	63	64	1	No
R-654	Figure A-8	B-Residential Apartment Floor 1	67	57	62	5	No
R-655	Figure A-8	B-Residential Apartment Floor 2	67	61	63	2	No
R-656	Figure A-8	B-Residential Apartment Floor 1	67	58	62	4	No
R-657	Figure A-8	B-Residential Apartment Floor 2	67	62	64	2	No
R-658	Figure A-8	B-Residential Apartment Floor 3	67	63	65	2	No
R-659	Figure A-8	B-Residential Apartment Floor 1	67	57	61	4	No
R-660	Figure A-8	B-Residential Apartment Floor 2	67	60	63	3	No
R-661	Figure A-8	B-Residential Apartment Floor 3	67	62	64	2	No
R-662	Figure A-8	B-Residential Apartment Floor 1	67	67	67	0	Yes
R-663	Figure A-8	B-Residential Apartment Floor 2	67	70	71	1	Yes
R-664	Figure A-8	B-Residential Apartment Floor 1	67	65	66	1	Yes
R-665	Figure A-8	B-Residential Apartment Floor 2	67	68	69	1	Yes
R-666	Figure A-8	B-Residential Apartment Floor 1	67	59	63	4	No
R-667	Figure A-8	B-Residential Apartment Floor 2	67	63	64	1	No
R-668	Figure A-8	B-Residential Apartment Floor 3	67	64	65	1	No
R-669	Figure A-8	B-Residential Apartment Floor 1	67	56	61	5	No
R-670	Figure A-8	B-Residential Apartment Floor 2	67	60	63	3	No

Traffic Noise Analysis Report

Table 3. Segment A Traffic Noise Levels dB(A) Leq

Segment A Representative Receiver	Figure	NAC Category	NAC Level	Existing	Predicted 2050	Change (+/-)	Noise Impact (Yes/No)
R-671	Figure A-8	B-Residential Apartment Floor 3	67	62	64	2	No
R-672	Figure A-8	B-Residential Apartment Floor 3	67	63	64	1	No
R-673	Figure A-8	B-Residential Apartment Floor 1	67	57	62	5	No
R-674	Figure A-8	B-Residential Apartment Floor 2	67	61	63	2	No
R-675	Figure A-8	B-Residential Apartment Floor 1	67	58	62	4	No
R-676	Figure A-8	B-Residential Apartment Floor 2	67	62	64	2	No
R-677	Figure A-8	B-Residential Apartment Floor 3	67	63	65	2	No
R-678	Figure A-8	C-Pool	67	62	65	3	No
R-679	Figure A-8	B-Residential Apartment Floor 1	67	61	64	3	No
R-680	Figure A-8	B-Residential Apartment Floor 2	67	65	66	1	Yes
R-681	Figure A-8	B-Residential Apartment Floor 1	67	66	67	1	Yes
R-682	Figure A-8	B-Residential Apartment Floor 2	67	69	69	0	Yes
R-683	Figure A-8	B-Residential Apartment Floor 1	67	63	65	2	No
R-684	Figure A-8	B-Residential Apartment Floor 2	67	67	67	0	Yes
R-685	Figure A-8	B-Residential Apartment Floor 1	67	64	66	2	Yes
R-686	Figure A-8	B-Residential Apartment Floor 2	67	67	68	1	Yes
R-687	Figure A-8	B-Residential Apartment Floor 1	67	59	63	4	No
R-688	Figure A-8	B-Residential Apartment Floor 2	67	63	65	2	No
R-689	Figure A-8	B-Residential Apartment Floor 3	67	65	66	1	Yes
R-690	Figure A-8	B-Residential Apartment Floor 3	67	62	64	2	No
R-691	Figure A-8	B-Residential Apartment Floor 1	67	57	61	4	No
R-692	Figure A-8	B-Residential Apartment Floor 2	67	61	63	2	No
R-693	Figure A-8	B-Residential Apartment Floor 3	67	64	65	1	No
R-694	Figure A-8	B-Residential Apartment Floor 1	67	58	62	4	No
R-695	Figure A-8	B-Residential Apartment Floor 2	67	62	64	2	No

Traffic Noise Analysis Report

Table 3. Segment A Traffic Noise Levels dB(A) Leq

Segment A Representative Receiver	Figure	NAC Category	NAC Level	Existing	Predicted 2050	Change (+/-)	Noise Impact (Yes/No)
R-696	Figure A-8	B-Residential Apartment Floor 1	67	58	62	4	No
R-697	Figure A-8	B-Residential Apartment Floor 2	67	61	63	2	No
R-698	Figure A-8	B-Residential Apartment Floor 3	67	63	65	2	No
R-699	Figure A-8	B-Residential Apartment Floor 1	67	63	65	2	No
R-700	Figure A-8	B-Residential Apartment Floor 2	67	67	67	0	Yes
R-701	Figure A-8	B-Residential Apartment Floor 1	67	64	66	2	Yes
R-702	Figure A-8	B-Residential Apartment Floor 2	67	67	68	1	Yes
R-703	Figure A-8	B-Residential Apartment Floor 1	67	61	64	3	No
R-704	Figure A-8	B-Residential Apartment Floor 2	67	65	66	1	Yes
R-705	Figure A-8	B-Residential Apartment Floor 1	67	66	67	1	Yes
R-706	Figure A-8	B-Residential Apartment Floor 2	67	69	69	0	Yes
R-707	Figure A-8	B-Residential Apartment Floor 1	67	59	62	3	No
R-708	Figure A-8	B-Residential Apartment Floor 2	67	62	64	2	No
R-709	Figure A-8	B-Residential Apartment Floor 3	67	64	65	1	No
R-710	Figure A-8	B-Residential Apartment Floor 1	67	58	62	4	No
R-711	Figure A-8	B-Residential Apartment Floor 2	67	61	63	2	No
R-712	Figure A-8	B-Residential Apartment Floor 3	67	63	65	2	No
R-713	Figure A-8	B-Residential Apartment Floor 1	67	60	63	3	No
R-714	Figure A-8	B-Residential Apartment Floor 2	67	63	65	2	No
R-715	Figure A-8	B-Residential Apartment Floor 3	67	65	66	1	Yes
R-716	Figure A-8	B-Residential Apartment Floor 1	67	57	61	4	No
R-717	Figure A-8	B-Residential Apartment Floor 2	67	61	63	2	No
R-718	Figure A-8	B-Residential Apartment Floor 3	67	62	64	2	No
R-719	Figure A-8	B-Residential Apartment Floor 1	67	67	67	0	Yes
R-720	Figure A-8	B-Residential Apartment Floor 2	67	70	70	0	Yes

Traffic Noise Analysis Report

Table 3. Segment A Traffic Noise Levels dB(A) Leq

Segment A Representative Receiver	Figure	NAC Category	NAC Level	Existing	Predicted 2050	Change (+/-)	Noise Impact (Yes/No)
R-721	Figure A-8	B-Residential Apartment Floor 1	67	62	65	3	No
R-722	Figure A-8	B-Residential Apartment Floor 2	67	66	67	1	Yes
R-723	Figure A-8	B-Residential Apartment Floor 1	67	60	63	3	No
R-724	Figure A-8	B-Residential Apartment Floor 2	67	64	65	1	No
R-725	Figure A-8	B-Residential Apartment Floor 3	67	65	67	2	Yes
R-726	Figure A-8	B-Residential Apartment Floor 1	67	64	65	1	No
R-727	Figure A-8	B-Residential Apartment Floor 2	67	67	68	1	Yes
R-728	Figure A-8	B-Residential Apartment Floor 1	67	65	66	1	Yes
R-729	Figure A-8	B-Residential Apartment Floor 2	67	68	69	1	Yes
R-730	Figure A-8	B-Residential Apartment Floor 3	67	64	66	2	Yes
R-731	Figure A-8	B-Residential Apartment Floor 1	67	59	63	4	No
R-732	Figure A-8	B-Residential Apartment Floor 2	67	63	65	2	No
R-733	Figure A-8	B-Residential Apartment Floor 1	67	58	62	4	No
R-734	Figure A-8	B-Residential Apartment Floor 2	67	61	63	2	No
R-735	Figure A-8	B-Residential Apartment Floor 3	67	63	64	1	No
R-736	Figure A-8	B-Residential Apartment Floor 1	67	59	62	3	No
R-737	Figure A-8	B-Residential Apartment Floor 2	67	62	64	2	No
R-738	Figure A-8	B-Residential Apartment Floor 3	67	64	65	1	No
R-739	Figure A-8	B-Residential Apartment Floor 1	67	66	66	0	Yes
R-740	Figure A-8	B-Residential Apartment Floor 2	67	68	69	1	Yes
R-741	Figure A-8	B-Residential Apartment Floor 1	67	64	66	2	Yes
R-742	Figure A-8	B-Residential Apartment Floor 2	67	67	68	1	Yes
R-743	Figure A-8	B-Residential Apartment Floor 1	67	60	63	3	No
R-744	Figure A-8	B-Residential Apartment Floor 2	67	63	65	2	No
R-745	Figure A-8	B-Residential Apartment Floor 3	67	65	66	1	Yes

Traffic Noise Analysis Report

Table 3. Segment A Traffic Noise Levels dB(A) Leq

Segment A Representative Receiver	Figure	NAC Category	NAC Level	Existing	Predicted 2050	Change (+/-)	Noise Impact (Yes/No)
R-746	Figure A-8	B-Residential Apartment Floor 1	67	61	64	3	No
R-747	Figure A-8	B-Residential Apartment Floor 2	67	64	65	1	No
R-748	Figure A-8	B-Residential Apartment Floor 3	67	66	67	1	Yes
R-749	Figure A-8	B-Residential Apartment Floor 1	67	59	62	3	No
R-750	Figure A-8	B-Residential Apartment Floor 2	67	62	64	2	No
R-751	Figure A-8	B-Residential Apartment Floor 3	67	64	65	1	No
R-752	Figure A-8	B-Residential Apartment Floor 1	67	67	67	0	Yes
R-753	Figure A-8	B-Residential Apartment Floor 2	67	70	70	0	Yes
R-754	Figure A-8	B-Residential Apartment Floor 1	67	63	65	2	No
R-755	Figure A-8	B-Residential Apartment Floor 2	67	66	67	1	Yes
R-756	Figure A-8	B-Residential Apartment Floor 1	67	58	62	4	No
R-757	Figure A-8	B-Residential Apartment Floor 2	67	61	64	3	No
R-758	Figure A-8	B-Residential Apartment Floor 3	67	63	65	2	No
R-759	Figure A-8	B-Residential Apartment Floor 1	67	56	61	5	No
R-760	Figure A-8	B-Residential Apartment Floor 2	67	60	63	3	No
R-761	Figure A-8	B-Residential Apartment Floor 3	67	61	64	3	No
R-762	Figure A-8	B-Residential Apartment Floor 1	67	61	63	2	No
R-763	Figure A-8	B-Residential Apartment Floor 2	67	64	66	2	Yes
R-764	Figure A-8	B-Residential Apartment Floor 3	67	66	67	1	Yes
R-765	Figure A-8	B-Residential Apartment Floor 1	67	59	62	3	No
R-766	Figure A-8	B-Residential Apartment Floor 2	67	63	64	1	No
R-767	Figure A-8	B-Residential Apartment Floor 3	67	64	65	1	No
R-768	Figure A-8	B-Residential Apartment Floor 1	67	60	63	3	No
R-769	Figure A-8	B-Residential Apartment Floor 2	67	63	65	2	No
R-770	Figure A-8	B-Residential Apartment Floor 3	67	65	66	1	Yes

Traffic Noise Analysis Report

Table 3. Segment A Traffic Noise Levels dB(A) Leq

Segment A Representative Receiver	Figure	NAC Category	NAC Level	Existing	Predicted 2050	Change (+/-)	Noise Impact (Yes/No)
R-771	Figure A-8	B-Residential Apartment Floor 1	67	58	62	4	No
R-772	Figure A-8	B-Residential Apartment Floor 2	67	62	64	2	No
R-773	Figure A-8	B-Residential Apartment Floor 3	67	63	65	2	No
R-774	Figure A-8	B-Residential Apartment Floor 1	67	56	61	5	No
R-775	Figure A-8	B-Residential Apartment Floor 2	67	60	63	3	No
R-776	Figure A-8	B-Residential Apartment Floor 3	67	62	64	2	No
R-777	Figure A-8	B-Residential Apartment Floor 3	67	66	67	1	Yes
R-778	Figure A-8	B-Residential Apartment Floor 1	67	61	63	2	No
R-779	Figure A-8	B-Residential Apartment Floor 2	67	65	65	0	No
R-780	Figure A-8	B-Residential Apartment Floor 1	67	60	63	3	No
R-781	Figure A-8	B-Residential Apartment Floor 2	67	63	65	2	No
R-782	Figure A-8	B-Residential Apartment Floor 3	67	65	66	1	Yes
R-783	Figure A-8	B-Residential Apartment Floor 1	67	58	62	4	No
R-784	Figure A-8	B-Residential Apartment Floor 2	67	62	64	2	No
R-785	Figure A-8	B-Residential Apartment Floor 3	67	63	65	2	No
R-786	Figure A-8	B-Residential Apartment Floor 1	67	59	62	3	No
R-787	Figure A-8	B-Residential Apartment Floor 2	67	63	64	1	No
R-788	Figure A-8	B-Residential Apartment Floor 3	67	64	65	1	No
R-789	Figure A-7	B-Residential	67	54	59	5	No
R-790	Figure A-7	B-Residential	67	55	60	5	No
R-791	Figure A-7	B-Residential	67	56	60	4	No
R-792	Figure A-7	B-Residential	67	57	61	4	No
R-793	Figure A-7	B-Residential	67	58	63	5	No
R-794	Figure A-7	B-Residential	67	57	61	4	No
R-795	Figure A-7	B-Residential	67	58	62	4	No
R-796	Figure A-7	B-Residential	67	59	65	6	No
R-797	Figure A-7	B-Residential	67	58	65	7	No
R-798	Figure A-7	B-Residential	67	56	58	2	No
R-799	Figure A-7	B-Residential	67	59	61	2	No

Traffic Noise Analysis Report

Table 3. Segment A Traffic Noise Levels dB(A) Leq

Segment A Representative Receiver	Figure	NAC Category	NAC Level	Existing	Predicted 2050	Change (+/-)	Noise Impact (Yes/No)
R-800	Figure A-7	B-Residential	67	56	58	2	No
R-801	Figure A-7	B-Residential	67	58	64	6	No
R-802	Figure A-7	B-Residential	67	57	59	2	No
R-803	Figure A-7	B-Residential	67	58	60	2	No
R-804	Figure A-7	B-Residential	67	59	60	1	No
R-805	Figure A-7	B-Residential	67	57	58	1	No
R-806	Figure A-7	B-Residential	67	58	64	6	No
R-807	Figure A-7	B-Residential	67	57	58	1	No
R-808	Figure A-7	B-Residential	67	59	60	1	No
R-809	Figure A-7	B-Residential	67	58	63	5	No
R-810	Figure A-7	B-Residential	67	58	58	0	No
R-811	Figure A-7	B-Residential	67	58	60	2	No
R-812	Figure A-7	B-Residential	67	58	59	1	No
R-813	Figure A-7	B-Residential	67	58	63	5	No
R-814	Figure A-7	B-Residential	67	58	59	1	No
R-815	Figure A-7	B-Residential	67	58	63	5	No
R-816	Figure A-7	B-Residential	67	58	59	1	No
R-817	Figure A-11	B-Residential	67	47	63	16	Yes
R-818	Figure A-7	B-Residential	67	57	62	5	No
R-819	Figure A-11	B-Residential	67	46	62	16	Yes
R-820	Figure A-7	B-Residential	67	57	62	5	No
R-821	Figure A-7	B-Residential	67	57	61	4	No
R-822	Figure A-11	B-Residential	67	46	67	21	Yes
R-823	Figure A-9	C-Hospital Floor 1	67	61	57	-4	No
R-824	Figure A-9	C-Hospital Floor 1	67	62	57	-5	No
R-825	Figure A-9	C-Hospital Floor 2	67	66	60	-6	No
R-826	Figure A-9	C-Hospital Floor 2	67	64	60	-4	No
R-827	Figure A-9	C-Hospital Floor 2	67	67	61	-6	No
R-828	Figure A-9	C-Hospital Floor 1	67	64	58	-6	No
R-829	Figure A-9	C-Hospital Floor 2	67	68	61	-7	No
R-830	Figure A-9	C-Hospital Floor 1	67	64	58	-6	No
R-831	Figure A-9	C-Hospital Floor 2	67	64	61	-3	No
R-832	Figure A-9	C-Hospital Floor 1	67	61	58	-3	No
R-833	Figure A-9	C-Hospital Floor 2	67	68	61	-7	No
R-834	Figure A-9	C-Hospital Floor 1	67	65	58	-7	No
R-835	Figure A-9	C-Hospital Floor 2	67	65	61	-4	No
R-836	Figure A-9	C-Hospital Floor 1	67	62	58	-4	No
R-837	Figure A-9	C-Hospital Floor 2	67	69	62	-7	No
R-838	Figure A-9	C-Hospital Floor 1	67	66	59	-7	No

Traffic Noise Analysis Report

Table 3. Segment A Traffic Noise Levels dB(A) Leq

Segment A Representative Receiver	Figure	NAC Category	NAC Level	Existing	Predicted 2050	Change (+/-)	Noise Impact (Yes/No)
R-839	Figure A-9	C-Hospital Floor 2	67	65	61	-4	No
R-840	Figure A-9	C-Hospital Floor 1	67	62	58	-4	No
R-841	Figure A-9	C-Hospital Floor 1	67	66	59	-7	No
R-842	Figure A-9	C-Hospital Floor 1	67	62	58	-4	No
R-843	Figure A-9	C-Hospital Floor 2	67	68	62	-6	No
R-844	Figure A-9	C-Hospital Floor 2	67	65	61	-4	No
R-845	Figure A-9	B-Residential	67	59	59	0	No
R-846	Figure A-9	C-Hospital Floor 2	67	68	62	-6	No
R-847	Figure A-9	C-Hospital Floor 1	67	66	60	-6	No
R-848	Figure A-9	C-Hospital Floor 2	67	65	61	-4	No
R-849	Figure A-9	C-Hospital Floor 1	67	62	59	-3	No
R-850	Figure A-9	C-Hospital Floor 2	67	66	62	-4	No
R-851	Figure A-9	C-Hospital Floor 1	67	64	59	-5	No
R-852	Figure A-9	C-Hospital Floor 2	67	67	62	-5	No
R-853	Figure A-9	C-Hospital Floor 1	67	65	59	-6	No
R-854	Figure A-9	B-Residential	67	60	59	-1	No
R-855	Figure A-9	B-Residential	67	59	58	-1	No
R-856	Figure A-9	B-Residential	67	59	58	-1	No
R-857	Figure A-9	B-Residential	67	59	58	-1	No
R-858	Figure A-9	B-Residential	67	60	59	-1	No
R-860	Figure A-9	B-Residential	67	62	59	-3	No
R-863	Figure A-12	B-Residential	67	46	60	14	Yes
R-867	Figure A-9	B-Residential	67	61	59	-2	No
R-870	Figure A-9	B-Residential	67	60	59	-1	No
R-873	Figure A-9	B-Residential	67	60	59	-1	No
R-877	Figure A-9	B-Residential	67	59	59	0	No
R-881	Figure A-9	B-Residential	67	59	59	0	No
R-884	Figure A-12	B-Residential	67	46	59	13	Yes
R-887	Figure A-9	B-Residential	67	59	59	0	No
R-894	Figure A-13	B-Residential	67	55	66	11	Yes
R-900	Figure A-11	C-Park	67	46	62	16	Yes
R-901	Figure A-11	C-Park	67	46	60	14	Yes
R-912	Figure A-12	B-Residential	67	46	63	17	Yes
R-918	Figure A-11	C-Park	67	46	58	12	Yes
R-919	Figure A-11	C-Park	67	46	58	12	Yes
R-925	Figure A-11	C-Park	67	46	58	12	Yes
R-939	Figure A-11	C-Park	67	46	57	11	Yes
R-946	Figure A-11	C-Park	67	46	57	11	Yes
R-948	Figure A-12	B-Residential	67	46	56	10	No

Table 3. Segment A Traffic Noise Levels dB(A) Leq

Segment A Representative Receiver	Figure	NAC Category	NAC Level	Existing	Predicted 2050	Change (+/-)	Noise Impact (Yes/No)
R-971	Figure A-11	C-Park	67	46	55	9	No
R-975	Figure A-11	C-Park	67	46	55	9	No

Abbreviations: NAC, Noise Abatement Criteria; dB(A), A-weighted decibel; Leq, average/equivalent sound level. Existing noise levels in **BOLD** were determined based on nearby ambient measurements. These receptors are not near any existing roadways that produce enough traffic noise to calculate existing noise levels. Data sheets are included in Attachments C and D.

As indicated in Table 3, the proposed project would result in a traffic noise impact at one or more representative receiver locations.

Noise abatement measures were considered for each location with predicted noise impacts.

Abatement Analysis

Noise barriers would not be feasible and reasonable for any of the following impacted receptors, and therefore, are not proposed for incorporation into the project:

R-161, R-466, R-516, and R-894 - These receptors are separate, isolated residences, which are not associated with a neighborhood or subdivision. Because a noise abatement measure must potentially benefit a minimum of two impacted receptors, noise abatement for these locations is not feasible.

Barrier A02: R-474 and R-477 (Figure A-5 and Figure A-6)– These receivers represent a total of 4 equivalent impacted dwelling units in La Cima Park along the Purple and Blue alternatives. Based on preliminary calculations, a noise barrier 607 feet in length, 20 feet in height, and located along the ROW would not be sufficient to achieve the minimum, feasible reduction of 5 dB(A) for a majority of impacted receptors or the noise reduction design goal of 7 dB(A).

Barrier A03: R-551 to R-552, R-554, R-559, R-562, R-568, R-572 and R-575 (Figure A-5 and Figure A-7)– These receivers represent a total of 8 impacted residences in the Tucker Hill neighborhood along the Purple and Blue alternatives. A continuous noise barrier 12 feet in height and approximately 883 feet in length was modeled along the mainline. This barrier would achieve the minimum feasible reduction of 5 dB(A) for four receptors while meeting the 7 dB(A) noise reduction design goal at one of those receptors. However, the square footage of abatement (10,596 square feet or 2,649 square feet per benefited receptor) would exceed the reasonable, cost-reasonableness criterion of 1,500 square feet per benefited receptor.

Barrier A04: R-573 and R-611 (Figure A-7)– These receivers represent a total of 2 impacted residences in the Stonebridge Ranch along the Purple and Blue alternatives. Based on preliminary calculations, a noise barrier 843 feet in length, 20 feet in height, and located along the ROW would not be sufficient to achieve the minimum, feasible reduction of 5 dB(A) for a majority of impacted receptors or the noise reduction design goal of 7 dB(A).

Barrier A05: R-817, R-819 and R-822 (Figure A-11) - These receivers represent a total of 3 impacted residences between ML 1519+00 and MB 1535+00 along the Purple and Blue alternatives. Based on preliminary calculations, a noise barrier 1,637 feet in length, 20 feet in height, and located along the ROW would not be sufficient to achieve the minimum, feasible reduction of 5 dB(A) for a majority of impacted receptors or the noise reduction design goal of 7 dB(A).

Traffic Noise Analysis Report

Barrier A06: R-863, R-884, R, and R-912 (Figure A-12)- These receivers represent a total of 3 impacted residential lots between ML 1545+00 and ML 1574+00 and ML 1575+00 and ML 1580+00 along the Purple and Blue alternatives. Based on preliminary calculations, a noise barrier 3,180 feet in length, 20 feet in height, and located along the ROW would not be sufficient to achieve the minimum, feasible reduction of 5 dB(A) for a majority of impacted receptors or the noise reduction design goal of 7 dB(A).

Barrier A08: R-900, R-901, R-918, R-919, R-925, R-939 and R-946 (Figure A-11)- These receivers represent a total of 161 equivalent dwelling units in the Zinger Bat Ball Park along the Purple and Blue alternatives. Based on preliminary calculations, a noise barrier 1,498 feet in length, 20 feet in height, and located along the ROW would not be sufficient to achieve the minimum, feasible reduction of 5 dB(A) for a majority of impacted receptors or the noise reduction design goal of 7 dB(A).

Barrier A09: R-125, R-127, R-131, R-135, R-139, R-147, R-153, R-157, and R-159 (Figure A-2) – These receivers represent a total of 9 equivalent dwelling units in the Red Bud Estates neighborhood along the Purple and Blue alternatives. A continuous noise barrier 17 feet in height and approximately 1,825 feet in length was modeled along the mainline. This barrier would achieve the minimum feasible reduction of 5 dB(A) for six receptors while meeting the 7 dB(A) noise reduction design goal at one of those receptors. However, the square footage of abatement (31,025 square feet or 6,205 square feet per benefited receptor) would exceed the reasonable, cost-reasonableness criterion of 1,500 square feet per benefited receptor.

Feasible and Reasonable Barriers

Noise barriers would be feasible and reasonable for the following impacted receptors, and therefore, are proposed for incorporation into the project. Table 4 summarizes the proposed noise barriers.

Table 4. Segment A Proposed Noise Barriers

Barrier	Locations	Receptor Number – Type	Number of Benefited Receivers	Length (feet)	Height (feet)	Total Barrier Area (ft ²)	Sq. Ft. / Benefited Receiver (ft)
A01	Prestwyck Neighborhood	R-19, R-23, R-29, R-31, R-35, R-37, R-41, R-43, R-45, R-47, R-49, R-51, R-53, R-59, R-61, R-63, R-67, R-71, R-73, R-75, R-77, R-79, R-89, R-93, R-107, and R-109 (Residential)	17	1,572	14	22,008	1,295
A07-2	Stonebridge Ranch	R-638 to R-649, R- 652, R-662 to R- 665, R-680 to R- 682, R-684 to R686, R-689, R- 700 to R-702, R- 704 to R-706, R- 715, R-719 to R- 720, R-722, R- 725, R-727 to R- 730, R-739 to R-	12	943	16	15,088	1,257

Traffic Noise Analysis Report

Barrier	Locations	Receptor Number - Type	Number of Benefited Receivers	Length (feet)	Height (feet)	Total Barrier Area (ft ²)	Sq. Ft. / Benefited Receiver (ft)
		742, R-745, R-748, R-752 to R-753, R-755, R-763, R-764, R-770, R-777, R-782 (Residential)					

Barrier A01: R-19, R-23, R-29, R-31, R-35, R-37, R-41, R-43, R-45, R-47, R-49, R-51, R-53, R-59, R-61, R-63, R-67, R-71, R-73, R-75, R-77, R-79, R-89, R-93, R-107, and R-109 (Figure A-1 and Figure A-2) – These receivers represent a total of 26 impacted residences at the Prestwyck Neighborhood along the Purple and Blue alternatives. Based on preliminary calculations, a noise barrier 1,572 feet in length, 14 feet in height, and located along the ROW would reduce noise levels by at least 5 dB(A) for 17 benefited receptors and meet the noise reduction design goal of 7 dB(A) for at least one of those receptors. With a total area of abatement of 22,008 square feet or 1,295 square feet per benefited receptor, the barrier would be cost reasonable. Therefore, Barrier A01 is considered acoustically feasible and cost effective.

Barrier A07 (Figure A-8): R-638 to R-649, R-652, R-662 to R-665, R-680 to R-682, R-684 to R686, R-689, R-700 to R-702, R-704 to R-706, R-715, R-719 to R-720, R-722, R-725, R-727 to R-730, R-739 to R-742, R-745, R-748, R-752 to R-753, R-755, R-763, R-764, R-770, R-777, R-782 (Figure A-7 and Figure A-8). Three –alternatives are analyzed for this barrier, they are Barrier A07-1, A07-2 and A07-3. Only Barrier A07-2 is reasonable and feasible. All alternatives cover the same receptors listed above.

Barrier A07-1: These receivers represent a total of 53 impacted residences in the Stonebridge Ranch neighborhood along the Purple and Blue alternatives. Based on preliminary calculations, a noise barrier 981 feet in length, 20 feet in height, and located along the frontage road would not be sufficient to achieve the minimum, feasible reduction of 5 dB(A) for a majority of impacted receptors or the noise reduction design goal of 7 dB(A).

Barrier A07-2: These receivers represent a total of 53 impacted residences at the Stonebridge Ranch neighborhood along the Purple and Blue alternatives. Based on preliminary calculations, a noise barrier 943 feet in length, 16 feet in height, and located along the ROW would reduce noise levels by at least 5 dB(A) for 12 benefited receptors and meet the noise reduction design goal of 7 dB(A) for at least one of those receptors. With a total area of abatement of 15,088 square feet or 1,257 square feet per benefited receptor, the barrier would be cost reasonable. Therefore, Barrier A07-2 is considered acoustically feasible and cost effective.

Barrier A07-3: These receivers represent a total of 53 impacted residences in the Stonebridge Ranch neighborhood along the Purple and Blue alternatives. Based on preliminary calculations, a noise barrier 962 feet in length, 20 feet in height, and located along the mainline would not be sufficient to achieve the minimum, feasible reduction of 5 dB(A) for a majority of impacted receptors or the noise reduction design goal of 7 dB(A).

Segment B

Segment B serves as a portion of the Brown and Gold alternatives. Segment B follows existing US 380 from Coit Road to west of N. Custer Road (FM 2478) where it turns northeast to intersect with N. Custer Road and

Traffic Noise Analysis Report

East First Street, then continues northeast to connect to Bloomdale Road at the future extension of Ridge Road.

Results

Table 5 provides a summary of the traffic noise impacts for Segment B according to evaluated land-use receptors.

Table 5. Summary of Traffic Noise Impacts for Segment B

NAC	RECEPTORS	IMPACTS
A	0	0
B	288	256
C	51	50
D	0	0
E	0	0
TOTAL	339	306

Existing and predicted traffic noise levels for Segment B were modeled at receiver locations listed in Table 6 that represent the land use activity areas adjacent to the proposed project that might be impacted by traffic noise and potentially benefit from feasible and reasonable noise abatement.

Table 6. Segment B Traffic Noise Levels dB(A) Leq

Segment B Representative Receiver	Figure	NAC Category	NAC Level	Existing	Predicted 2050	Change (+/-)	Noise Impact (Yes/No)
R-1	Figure B-1	B-Residential	67	60	64	4	No
R-3	Figure B-1	B-Residential	67	60	64	4	No
R-5	Figure B-1	B-Residential	67	60	64	4	No
R-7	Figure B-1	B-Residential	67	62	66	4	Yes
R-9	Figure B-1	B-Residential	67	55	59	4	No
R-11	Figure B-1	B-Residential	67	61	65	4	No
R-13	Figure B-1	B-Residential	67	61	66	5	Yes
R-15	Figure B-1	B-Residential	67	56	60	4	No
R-17	Figure B-1	B-Residential	67	61	66	5	Yes
R-19	Figure B-1	B-Residential	67	63	67	4	Yes
R-21	Figure B-1	B-Residential	67	56	61	5	No
R-23	Figure B-1	B-Residential	67	63	68	5	Yes
R-25	Figure B-1	B-Residential	67	61	66	5	Yes
R-27	Figure B-1	B-Residential	67	57	61	4	No
R-29	Figure B-1	B-Residential	67	63	68	5	Yes
R-31	Figure B-1	B-Residential	67	61	66	5	Yes
R-33	Figure B-1	B-Residential	67	59	63	4	No
R-35	Figure B-1	B-Residential	67	61	66	5	Yes
R-37	Figure B-1	B-Residential	67	64	69	5	Yes
R-39	Figure B-1	B-Residential	67	61	65	4	No
R-41	Figure B-1	B-Residential	67	62	67	5	Yes

Traffic Noise Analysis Report

Table 6. Segment B Traffic Noise Levels dB(A) Leq

Segment B Representative Receiver	Figure	NAC Category	NAC Level	Existing	Predicted 2050	Change (+/-)	Noise Impact (Yes/No)
R-43	Figure B-1	B-Residential	67	62	66	4	Yes
R-45	Figure B-1	B-Residential	67	64	69	5	Yes
R-47	Figure B-1	B-Residential	67	62	67	5	Yes
R-49	Figure B-1	B-Residential	67	65	70	5	Yes
R-51	Figure B-1	B-Residential	67	68	73	5	Yes
R-53	Figure B-1	B-Residential	67	62	67	5	Yes
R-55	Figure B-1	B-Residential	67	60	64	4	No
R-57	Figure B-1	B-Residential	67	61	66	5	Yes
R-59	Figure B-1	B-Residential	67	64	69	5	Yes
R-61	Figure B-1	B-Residential	67	68	73	5	Yes
R-63	Figure B-1	B-Residential	67	63	68	5	Yes
R-65	Figure B-1	B-Residential	67	61	66	5	Yes
R-67	Figure B-1	B-Residential	67	62	67	5	Yes
R-69	Figure B-1	B-Residential	67	60	64	4	No
R-71	Figure B-1	B-Residential	67	68	72	4	Yes
R-73	Figure B-1	B-Residential	67	65	69	4	Yes
R-75	Figure B-1	B-Residential	67	65	70	5	Yes
R-77	Figure B-1	B-Residential	67	64	68	4	Yes
R-79	Figure B-1	B-Residential	67	63	67	4	Yes
R-81	Figure B-1	B-Residential	67	61	66	5	Yes
R-83	Figure B-1	B-Residential	67	60	64	4	No
R-85	Figure B-2	B-Residential	67	62	66	4	Yes
R-87	Figure B-2	B-Residential	67	62	67	5	Yes
R-89	Figure B-2	B-Residential	67	64	69	5	Yes
R-91	Figure B-2	B-Residential	67	62	67	5	Yes
R-93	Figure B-2	B-Residential	67	63	68	5	Yes
R-95	Figure B-2	B-Residential	67	58	63	5	No
R-97	Figure B-2	B-Residential	67	59	64	5	No
R-99	Figure B-2	B-Residential	67	59	64	5	No
R-101	Figure B-2	B-Residential	67	62	67	5	Yes
R-103	Figure B-2	B-Residential	67	58	63	5	No
R-105	Figure B-2	B-Residential	67	62	67	5	Yes
R-107	Figure B-2	B-Residential	67	65	70	5	Yes
R-109	Figure B-2	B-Residential	67	64	68	4	Yes
R-111	Figure B-2	B-Residential	67	61	66	5	Yes
R-113	Figure B-2	B-Residential	67	62	67	5	Yes
R-115	Figure B-2	B-Residential	67	60	65	5	No
R-117	Figure B-2	B-Residential	67	59	64	5	No
R-119	Figure B-2	B-Residential	67	60	64	4	No

Traffic Noise Analysis Report

Table 6. Segment B Traffic Noise Levels dB(A) Leq

Segment B Representative Receiver	Figure	NAC Category	NAC Level	Existing	Predicted 2050	Change (+/-)	Noise Impact (Yes/No)
R-121	Figure B-2	B-Residential	67	58	63	5	No
R-123	Figure B-2	B-Residential	67	59	65	6	No
R-125	Figure B-2	B-Residential	67	63	68	5	Yes
R-127	Figure B-2	B-Residential	67	68	71	3	Yes
R-129	Figure B-2	B-Residential	67	59	65	6	No
R-131	Figure B-2	B-Residential	67	67	70	3	Yes
R-133	Figure B-2	B-Residential	67	59	65	6	No
R-135	Figure B-2	B-Residential	67	70	71	1	Yes
R-137	Figure B-2	B-Residential	67	59	65	6	No
R-139	Figure B-2	B-Residential	67	66	70	4	Yes
R-141	Figure B-2	B-Residential	67	59	65	6	No
R-143	Figure B-2	B-Residential	67	59	65	6	No
R-145	Figure B-2	B-Residential	67	59	64	5	No
R-147	Figure B-2	B-Residential	67	68	70	2	Yes
R-149	Figure B-2	B-Residential	67	59	64	5	No
R-151	Figure B-2	B-Residential	67	57	64	7	No
R-153	Figure B-2	B-Residential	67	61	66	5	Yes
R-155	Figure B-2	B-Residential	67	59	65	6	No
R-157	Figure B-2	B-Residential	67	67	70	3	Yes
R-159	Figure B-2	B-Residential	67	62	66	4	Yes
R-161	Figure B-2	B-Residential	67	63	64	1	No
R-163	Figure B-6	B-Residential	67	38	59	21	Yes
R-164	Figure B-6	B-Residential	67	37	55	18	Yes
R-165	Figure B-6	B-Residential	67	37	56	19	Yes
R-166	Figure B-6	B-Residential	67	38	59	21	Yes
R-167	Figure B-6	B-Residential	67	37	56	19	Yes
R-168	Figure B-6	B-Residential	67	37	57	20	Yes
R-169	Figure B-6	B-Residential	67	38	57	19	Yes
R-170	Figure B-6	B-Residential	67	38	58	20	Yes
R-171	Figure B-6	B-Residential	67	38	61	23	Yes
R-179	Figure B-6	B-Residential	67	38	63	25	Yes
R-181	Figure B-6	B-Residential	67	37	56	19	Yes
R-184	Figure B-6	B-Residential	67	37	57	20	Yes
R-185	Figure B-6	B-Residential	67	37	57	20	Yes
R-186	Figure B-6	B-Residential	67	38	58	20	Yes
R-189	Figure B-6	B-Residential	67	38	60	22	Yes
R-190	Figure B-6	B-Residential	67	38	61	23	Yes
R-192	Figure B-6	B-Residential	67	38	64	26	Yes
R-194	Figure B-6	B-Residential	67	37	57	20	Yes

Traffic Noise Analysis Report

Table 6. Segment B Traffic Noise Levels dB(A) Leq

Segment B Representative Receiver	Figure	NAC Category	NAC Level	Existing	Predicted 2050	Change (+/-)	Noise Impact (Yes/No)
R-197	Figure B-6	B-Residential	67	38	63	25	Yes
R-199	Figure B-6	B-Residential	67	38	58	20	Yes
R-203	Figure B-6	B-Residential	67	37	57	20	Yes
R-204	Figure B-6	B-Residential	67	38	65	27	Yes
R-205	Figure B-6	B-Residential	67	38	61	23	Yes
R-210	Figure B-6	B-Residential	67	38	58	20	Yes
R-213	Figure B-6	B-Residential	67	38	62	24	Yes
R-214	Figure B-6	B-Residential	67	38	57	19	Yes
R-215	Figure B-6	B-Residential	67	38	64	26	Yes
R-216	Figure B-6	B-Residential	67	38	66	28	Yes
R-218	Figure B-6	B-Residential	67	38	59	21	Yes
R-221	Figure B-6	B-Residential	67	38	62	24	Yes
R-223	Figure B-6	B-Residential	67	38	58	20	Yes
R-224	Figure B-6	B-Residential	67	38	65	27	Yes
R-227	Figure B-6	B-Residential	67	38	68	30	Yes
R-228	Figure B-6	B-Residential	67	38	59	21	Yes
R-230	Figure B-6	B-Residential	67	38	62	24	Yes
R-233	Figure B-6	B-Residential	67	38	58	20	Yes
R-234	Figure B-6	B-Residential	67	38	66	28	Yes
R-235	Figure B-6	B-Residential	67	38	67	29	Yes
R-236	Figure B-6	B-Residential	67	38	65	27	Yes
R-238	Figure B-6	B-Residential	67	38	69	31	Yes
R-239	Figure B-6	B-Residential	67	38	60	22	Yes
R-240	Figure B-6	B-Residential	67	38	63	25	Yes
R-247	Figure B-6	B-Residential	67	38	59	21	Yes
R-248	Figure B-6	B-Residential	67	38	59	21	Yes
R-249	Figure B-6	B-Residential	67	38	60	22	Yes
R-250	Figure B-6	B-Residential	67	38	61	23	Yes
R-251	Figure B-6	B-Residential	67	38	68	30	Yes
R-252	Figure B-6	B-Residential	67	38	67	29	Yes
R-253	Figure B-6	B-Residential	67	38	66	28	Yes
R-254	Figure B-6	B-Residential	67	38	63	25	Yes
R-255	Figure B-6	B-Residential	67	38	58	20	Yes
R-256	Figure B-6	B-Residential	67	38	68	30	Yes
R-257	Figure B-6	B-Residential	67	38	69	31	Yes
R-258	Figure B-6	B-Residential	67	38	70	32	Yes
R-259	Figure B-6	B-Residential	67	38	71	33	Yes
R-260	Figure B-6	B-Residential	67	38	71	33	Yes
R-261	Figure B-6	B-Residential	67	39	68	29	Yes

Traffic Noise Analysis Report

Table 6. Segment B Traffic Noise Levels dB(A) Leq

Segment B Representative Receiver	Figure	NAC Category	NAC Level	Existing	Predicted 2050	Change (+/-)	Noise Impact (Yes/No)
R-262	Figure B-6	B-Residential	67	39	67	28	Yes
R-263	Figure B-6	B-Residential	67	39	63	24	Yes
R-264	Figure B-6	B-Residential	67	39	61	22	Yes
R-265	Figure B-6	B-Residential	67	39	60	21	Yes
R-266	Figure B-6	B-Residential	67	39	58	19	Yes
R-267	Figure B-6	B-Residential	67	39	61	22	Yes
R-268	Figure B-6	B-Residential	67	39	60	21	Yes
R-269	Figure B-6	B-Residential	67	39	62	23	Yes
R-270	Figure B-6	B-Residential	67	39	67	28	Yes
R-271	Figure B-6	B-Residential	67	39	62	23	Yes
R-272	Figure B-6	B-Residential	67	39	64	25	Yes
R-273	Figure B-6	B-Residential	67	39	59	20	Yes
R-274	Figure B-6	B-Residential	67	39	66	27	Yes
R-275	Figure B-6	B-Residential	67	39	60	21	Yes
R-276	Figure B-6	B-Residential	67	39	60	21	Yes
R-277	Figure B-6	B-Residential	67	39	61	22	Yes
R-278	Figure B-6	B-Residential	67	39	61	22	Yes
R-279	Figure B-7	C-School	67	39	57	18	Yes
R-280	Figure B-6	B-Residential	67	39	59	20	Yes
R-281	Figure B-6	B-Residential	67	39	66	27	Yes
R-282	Figure B-6	B-Residential	67	39	72	33	Yes
R-283	Figure B-6	B-Residential	67	39	73	34	Yes
R-284	Figure B-6	B-Residential	67	39	71	32	Yes
R-285	Figure B-6	B-Residential	67	39	62	23	Yes
R-286	Figure B-6	B-Residential	67	39	66	27	Yes
R-287	Figure B-6	B-Residential	67	39	70	31	Yes
R-288	Figure B-6	B-Residential	67	39	70	31	Yes
R-289	Figure B-6	B-Residential	67	39	59	20	Yes
R-290	Figure B-6	B-Residential	67	39	64	25	Yes
R-291	Figure B-6	B-Residential	67	39	61	22	Yes
R-292	Figure B-6	B-Residential	67	39	63	24	Yes
R-293	Figure B-6	B-Residential	67	39	62	23	Yes
R-294	Figure B-6	B-Residential	67	39	61	22	Yes
R-295	Figure B-6	B-Residential	67	39	67	28	Yes
R-296	Figure B-6	B-Residential	67	39	59	20	Yes
R-297	Figure B-6	B-Residential	67	39	69	30	Yes
R-298	Figure B-6	B-Residential	67	39	67	28	Yes
R-299	Figure B-6	B-Residential	67	39	70	31	Yes
R-300	Figure B-6	B-Residential	67	40	60	20	Yes

Traffic Noise Analysis Report

Table 6. Segment B Traffic Noise Levels dB(A) Leq

Segment B Representative Receiver	Figure	NAC Category	NAC Level	Existing	Predicted 2050	Change (+/-)	Noise Impact (Yes/No)
R-301	Figure B-6	B-Residential	67	40	67	27	Yes
R-302	Figure B-6	B-Residential	67	39	70	31	Yes
R-303	Figure B-6	B-Residential	67	40	60	20	Yes
R-304	Figure B-6	B-Residential	67	40	67	27	Yes
R-305	Figure B-6	B-Residential	67	40	70	30	Yes
R-306	Figure B-6	B-Residential	67	40	62	22	Yes
R-307	Figure B-6	B-Residential	67	40	62	22	Yes
R-308	Figure B-6	B-Residential	67	40	60	20	Yes
R-309	Figure B-6	B-Residential	67	40	67	27	Yes
R-310	Figure B-6	B-Residential	67	40	70	30	Yes
R-311	Figure B-6	B-Residential	67	40	63	23	Yes
R-312	Figure B-6	B-Residential	67	40	61	21	Yes
R-313	Figure B-6	B-Residential	67	40	68	28	Yes
R-314	Figure B-6	B-Residential	67	40	70	30	Yes
R-315	Figure B-6	B-Residential	67	40	62	22	Yes
R-316	Figure B-6	B-Residential	67	39	69	30	Yes
R-317	Figure B-6	B-Residential	67	41	61	20	Yes
R-318	Figure B-6	B-Residential	67	40	70	30	Yes
R-319	Figure B-6	B-Residential	67	40	68	28	Yes
R-320	Figure B-6	B-Residential	67	41	63	22	Yes
R-321	Figure B-6	B-Residential	67	39	68	29	Yes
R-322	Figure B-6	B-Residential	67	41	71	30	Yes
R-323	Figure B-6	B-Residential	67	41	68	27	Yes
R-324	Figure B-6	B-Residential	67	41	62	21	Yes
R-325	Figure B-6	B-Residential	67	41	63	22	Yes
R-326	Figure B-6	B-Residential	67	39	68	29	Yes
R-327	Figure B-6	B-Residential	67	41	72	31	Yes
R-328	Figure B-6	B-Residential	67	41	69	28	Yes
R-329	Figure B-6	B-Residential	67	41	62	21	Yes
R-330	Figure B-6	B-Residential	67	41	64	23	Yes
R-331	Figure B-6	B-Residential	67	40	68	28	Yes
R-332	Figure B-6	B-Residential	67	41	69	28	Yes
R-333	Figure B-6	B-Residential	67	42	62	20	Yes
R-334	Figure B-6	B-Residential	67	42	64	22	Yes
R-335	Figure B-6	B-Residential	67	40	68	28	Yes
R-336	Figure B-6	B-Residential	67	40	69	29	Yes
R-337	Figure B-6	B-Residential	67	42	70	28	Yes
R-338	Figure B-6	B-Residential	67	42	63	21	Yes
R-339	Figure B-6	B-Residential	67	42	74	32	Yes

Traffic Noise Analysis Report

Table 6. Segment B Traffic Noise Levels dB(A) Leq

Segment B Representative Receiver	Figure	NAC Category	NAC Level	Existing	Predicted 2050	Change (+/-)	Noise Impact (Yes/No)
R-340	Figure B-6	B-Residential	67	42	65	23	Yes
R-341	Figure B-6	B-Residential	67	42	65	23	Yes
R-342	Figure B-6	B-Residential	67	42	71	29	Yes
R-343	Figure B-6	B-Residential	67	42	63	21	Yes
R-344	Figure B-6	B-Residential	67	43	68	25	Yes
R-345	Figure B-6	B-Residential	67	43	64	21	Yes
R-346	Figure B-6	B-Residential	67	43	71	28	Yes
R-347	Figure B-6	B-Residential	67	43	66	23	Yes
R-348	Figure B-6	B-Residential	67	43	64	21	Yes
R-349	Figure B-6	B-Residential	67	43	72	29	Yes
R-350	Figure B-6	B-Residential	67	41	69	28	Yes
R-351	Figure B-7	C-School	67	43	63	20	Yes
R-352	Figure B-7	C-School	67	43	63	20	Yes
R-353	Figure B-7	C-School	67	43	62	19	Yes
R-354	Figure B-7	C-School	67	43	63	20	Yes
R-355	Figure B-6	B-Residential	67	43	68	25	Yes
R-356	Figure B-6	B-Residential	67	44	65	21	Yes
R-357	Figure B-7	C-School	67	44	63	19	Yes
R-358	Figure B-7	C-School	67	44	63	19	Yes
R-359	Figure B-6	B-Residential	67	44	73	29	Yes
R-360	Figure B-6	B-Residential	67	42	67	25	Yes
R-361	Figure B-6	B-Residential	67	42	71	29	Yes
R-362	Figure B-6	B-Residential	67	44	69	25	Yes
R-363	Figure B-7	C-School	67	44	62	18	Yes
R-364	Figure B-5	C-Cemetery	67	38	58	20	Yes
R-365	Figure B-7	C-School	67	44	64	20	Yes
R-366	Figure B-7	C-School	67	44	63	19	Yes
R-367	Figure B-6	B-Residential	67	44	65	21	Yes
R-368	Figure B-6	B-Residential	67	42	67	25	Yes
R-369	Figure B-6	B-Residential	67	45	70	25	Yes
R-370	Figure B-7	C-School	67	45	64	19	Yes
R-371	Figure B-7	C-School	67	45	64	19	Yes
R-372	Figure B-6	B-Residential	67	45	66	21	Yes
R-373	Figure B-6	B-Residential	67	43	69	26	Yes
R-374	Figure B-6	B-Residential	67	43	67	24	Yes
R-375	Figure B-7	C-School	67	45	64	19	Yes
R-376	Figure B-7	C-School	67	45	64	19	Yes
R-377	Figure B-7	C-School	67	45	64	19	Yes
R-378	Figure B-7	C-School	67	45	65	20	Yes

Traffic Noise Analysis Report

Table 6. Segment B Traffic Noise Levels dB(A) Leq

Segment B Representative Receiver	Figure	NAC Category	NAC Level	Existing	Predicted 2050	Change (+/-)	Noise Impact (Yes/No)
R-379	Figure B-6	B-Residential	67	45	70	25	Yes
R-380	Figure B-6	B-Residential	67	44	68	24	Yes
R-381	Figure B-6	B-Residential	67	46	69	23	Yes
R-382	Figure B-6	B-Residential	67	44	66	22	Yes
R-383	Figure B-6	B-Residential	67	46	71	25	Yes
R-384	Figure B-7	C-School	67	47	63	16	Yes
R-385	Figure B-6	B-Residential	67	47	67	20	Yes
R-386	Figure B-6	B-Residential	67	45	68	23	Yes
R-387	Figure B-6	B-Residential	67	44	66	22	Yes
R-388	Figure B-6	B-Residential	67	47	69	22	Yes
R-389	Figure B-6	B-Residential	67	46	68	22	Yes
R-390	Figure B-6	B-Residential	67	45	66	21	Yes
R-391	Figure B-7	C-School Floor 2	67	52	66	14	Yes
R-392	Figure B-7	C-School Floor 1	67	49	64	15	Yes
R-393	Figure B-7	C-School Floor 2	67	52	66	14	Yes
R-394	Figure B-7	C-School	67	48	64	16	Yes
R-395	Figure B-7	C-School Floor 2	67	53	65	12	Yes
R-396	Figure B-7	C-School	67	49	63	14	Yes
R-397	Figure B-6	B-Residential	67	48	69	21	Yes
R-398	Figure B-6	B-Residential	67	47	68	21	Yes
R-399	Figure B-6	B-Residential	67	46	66	20	Yes
R-400	Figure B-7	C-School Floor 1	67	49	65	16	Yes
R-401	Figure B-7	C-School Floor 2	67	54	67	13	Yes
R-402	Figure B-7	C-School Floor 2	67	54	66	12	Yes
R-403	Figure B-7	C-School Floor 1	67	50	64	14	Yes
R-404	Figure B-6	B-Residential	67	48	68	20	Yes
R-405	Figure B-6	B-Residential	67	49	70	21	Yes
R-406	Figure B-6	B-Residential	67	47	66	19	Yes
R-407	Figure B-7	C-School Floor 1	67	50	65	15	Yes
R-408	Figure B-7	C-School Floor 2	67	55	67	12	Yes
R-409	Figure B-7	C-School Floor 2	67	55	66	11	Yes
R-410	Figure B-7	C-School Floor 1	67	51	64	13	Yes
R-411	Figure B-6	B-Residential	67	49	68	19	Yes
R-412	Figure B-6	B-Residential	67	48	66	18	Yes
R-413	Figure B-7	C-School Floor 2	67	56	66	10	Yes
R-414	Figure B-7	C-School Floor 1	67	52	64	12	Yes
R-415	Figure B-7	C-School Floor 1	67	52	66	14	Yes
R-416	Figure B-7	C-School Floor 2	67	56	67	11	Yes
R-417	Figure B-6	B-Residential	67	50	69	19	Yes

Traffic Noise Analysis Report

Table 6. Segment B Traffic Noise Levels dB(A) Leq

Segment B Representative Receiver	Figure	NAC Category	NAC Level	Existing	Predicted 2050	Change (+/-)	Noise Impact (Yes/No)
R-418	Figure B-6	B-Residential	67	50	69	19	Yes
R-419	Figure B-6	B-Residential	67	50	67	17	Yes
R-420	Figure B-6	B-Residential	67	51	70	19	Yes
R-421	Figure B-6	B-Residential	67	50	66	16	Yes
R-422	Figure B-6	B-Residential	67	51	71	20	Yes
R-423	Figure B-6	B-Residential	67	51	72	21	Yes
R-424	Figure B-7	C-School Floor 2	67	58	66	8	Yes
R-425	Figure B-7	C-School Floor 1	67	54	65	11	Yes
R-426	Figure B-7	C-School Floor 1	67	54	66	12	Yes
R-427	Figure B-7	C-School Floor 2	67	58	68	10	Yes
R-428	Figure B-6	B-Residential	67	52	71	19	Yes
R-429	Figure B-6	B-Residential	67	51	65	14	Yes
R-430	Figure B-7	C-School Floor 1	67	55	66	11	Yes
R-431	Figure B-7	C-School Floor 2	67	59	68	9	Yes
R-432	Figure B-7	C-School	67	55	67	12	Yes
R-433	Figure B-7	C-School Floor 2	67	59	68	9	Yes
R-434	Figure B-7	C-School Floor 2	67	60	67	7	Yes
R-435	Figure B-7	C-School	67	56	65	9	No
R-436	Figure B-6	B-Residential	67	54	71	17	Yes
R-437	Figure B-6	B-Residential	67	53	65	12	Yes
R-438	Figure B-6	B-Residential	67	55	67	12	Yes
R-439	Figure B-6	B-Residential	67	55	66	11	Yes
R-440	Figure B-6	B-Residential	67	56	68	12	Yes
R-441	Figure B-6	B-Residential	67	56	68	12	Yes
R-442	Figure B-6	B-Residential	67	57	69	12	Yes
R-443	Figure B-6	B-Residential	67	57	72	15	Yes
R-444	Figure B-6	B-Residential	67	57	69	12	Yes
R-445	Figure B-6	B-Residential	67	57	70	13	Yes
R-446	Figure B-6	B-Residential	67	58	71	13	Yes
R-447	Figure B-6	B-Residential	67	58	72	14	Yes
R-448	Figure B-6	C-Institutional	67	52	69	17	Yes
R-449	Figure B-7	B-Residential	67	49	62	13	Yes
R-450	Figure B-7	C-Institutional	67	47	67	20	Yes
R-451	Figure B-7	C-Institutional	67	47	71	24	Yes
R-452	Figure B-7	C-Institutional	67	46	64	18	Yes
R-453	Figure B-7	B-Residential	67	44	62	18	Yes
R-454	Figure B-7	B-Residential	67	44	63	19	Yes
R-456	Figure B-7	B-Residential	67	42	64	22	Yes
R-457	Figure B-7	C-Institutional	67	40	71	31	Yes

Table 6. Segment B Traffic Noise Levels dB(A) Leq

Segment B Representative Receiver	Figure	NAC Category	NAC Level	Existing	Predicted 2050	Change (+/-)	Noise Impact (Yes/No)
R-459	Figure B-7	B-Residential	67	40	66	26	Yes
R-460	Figure B-7	B-Residential	67	41	69	28	Yes
R-463	Figure B-8	B-Residential	67	37	68	31	Yes
R-464	Figure B-8	B-Residential	67	37	61	24	Yes
R-894	Figure B-11	B-Residential	67	55	68	13	Yes
R-912	Figure B-11	B-Residential	67	46	61	15	Yes

Abbreviations: NAC, Noise Abatement Criteria; dB(A), A-weighted decibel; Leq, average/equivalent sound level. Existing noise levels in **BOLD** were determined based on nearby ambient measurements. These receptors are not near any existing roadways that produce enough traffic noise to calculate existing noise levels. Data sheets are included in Attachments C and D.

As indicated in Table 6, the proposed project would result in a traffic noise impact at one or more representative receiver locations.

Noise abatement measures were considered for each location with predicted noise impacts.

Abatement Analysis

Noise barriers would not be feasible and reasonable for any of the following impacted receptors, and therefore, are not proposed for incorporation into the project:

R-364, R-894, and R-912 - These receptors are separate, isolated residences, which are not associated with a neighborhood or subdivision. Because a noise abatement measure must potentially benefit a minimum of two impacted receptors, noise abatement for these locations is not feasible.

Barrier B04: R-449, R-453, R-454, R-456, R-459, and R-460 (Figure B-7) - These receivers represent a total of 7 equivalent impacted dwelling units between ML 1433+00 and ML 1447+00 along the Brown and Gold alternatives. Based on preliminary calculations, a noise barrier 1,383 feet in length, 20 feet in height, and located along the ROW would not be sufficient to achieve the minimum, feasible reduction of 5 dB(A) for a majority of impacted receptors or the noise reduction design goal of 7 dB(A).

Barrier B06: R-125, R-127, R-131, R-135, R-139, R-147, R-153, R-157, and R-159 (Figure B-2) - These receivers represent a total of 9 impacted residences at the Red Bud Estates neighborhood along the Brown and Gold alternatives. A continuous noise barrier 18 feet in height and approximately 1,825 feet in length was modeled along the ROW. This barrier would achieve the minimum feasible reduction of 5 dB(A) for six receptors while meeting the 7 dB(A) noise reduction design goal at one of those receptors. However, the square footage of abatement (32,850 square feet or 5,475 square feet per benefited receptor) would exceed the reasonable, cost-reasonableness criterion of 1,500 square feet per benefited receptor.

Feasible and Reasonable Barriers

Noise barriers would be feasible and reasonable for the following impacted receptors, and therefore, are proposed for incorporation into the project. Table 7 summarizes the proposed noise barriers.

Table 7: Segment B Proposed Noise Barriers

Barrier	Locations	Receptor Number - Type	Number of Benefited Receivers	Length (feet)	Height (feet)	Total Barrier Area (ft ²)	Sq. Ft. / Benefited Receiver (ft)
B01	Prestwyck Neighborhood	R-7, R-13, R-17, R-19, R-23, R-25, R-29, R-31, R-35, R-37, R-41, R-43, R-45, R-47, R-49, R-51, R-53, R-57, R-59, R-61, R-63, R-65, R-67, R-71, R-73, R-75, R-77, R-79, R-81, R-85, R-87, R-89, R-91, R-93, R-101, R-105, R-107, R-109, R-111, and R-113 (Residential)	17	1,572	14	22,008	1,295
B02	Ladera Prosper*	R-316, R-321, R-326, R-331, R-335, R-336, R-350, R-360, R-361, R-368, R-373, R-374, R-380, R-382, R-386, R-387, R-389, R-390, R-398, R-399, R-404, R-406, R-411, R-412, R-417 to R-423, R-429, R-437 to R-442, and R-444 to R-447 (Residential)	23	1,641	20	32,820	1,427
B03	Ladera Prosper*	R-163 to R-171, R-179, R-181, R-184 to R-186, R-189, R-190, R-192, R-194, R-197, R-199, R-203 to R-205, R-210, R-213 to R-216, R-218, R-221, R-223, R-224, R-227, R-228, R-230, R-233 to R-236, R-238 to R-240, R-247 to R-315, R-317 to R-320, R-322 to R-325, R-327 to R-330, R-332 to R-334, R-337 to R-349, R-351 to R-359, R-362, R-363, R-365	36	3,108	17	52,836	1,468

Table 7: Segment B Proposed Noise Barriers

Barrier	Locations	Receptor Number - Type	Number of Benefited Receivers	Length (feet)	Height (feet)	Total Barrier Area (ft ²)	Sq. Ft. / Benefited Receiver (ft)
		to R-367, R-369 to R-372, R-375 to R-379, R-381, R-383 to R-385, R-388, R-391 to R-397, R-400 to R403, R-405, R-407 to R-410, R-413 to R-416, R-424 to R-428, R-430 to R-434, R-436, and R-443(Residential)					
B05-1	ManeGait	R-448, R-450 to R-452, R-457, R-463, and R-464 (Park)	2	2,155	16	34,480	663

*Note: This development is either under construction or permitted for development. At the time the noise model was conducted, none of the receptors in the development were present.

Barrier B01: R-7, R-13, R-17, R-19, R-23, R-25, R-29, R-31, R-35, R-37, R-41, R-43, R-45, R-47, R-49, R-51, R-53, R-57, R-59, R-61, R-63, R-65, R-67, R-71, R-73, R-75, R-77, R-79, R-81, R-85, R-87, R-89, R-91, R-93, R-101, R-105, R-107, R-109, R-111, and R-113 (Figure B-1 and Figure B-2) These receivers represent a total of 40 impacted residences at the Prestwyck Neighborhood along the Brown and Gold alternatives. Based on preliminary calculations, a noise barrier 1,572 feet in length, 14 feet in height, and located along the ROW would reduce noise levels by at least 5 dB(A) for 17 benefited receptors and meet the noise reduction design goal of 7 dB(A) for at least one of those receptors. With a total area of abatement of 22,008 square feet or 1,295 square feet per benefited receptor, the barrier would be cost reasonable. Therefore, Barrier B01 is considered acoustically feasible and cost effective.

Barrier B02: R-316, R-321, R-326, R-331, R-335, R-336, R-350, R-360, R-361, R-368, R-373, R-374, R-380, R-382, R-386, R-387, R-389, R-390, R-398, R399, R-404, R-406, R-411, R412, R-417 to R-423, R-429, R-437 to R-442, and R-444 to R-447 (Figure B-6)- These receivers represent a total of 42 impacted residences at the Ladera Prosper neighborhood along the Brown and Gold Alternatives. Based on preliminary calculations, a noise barrier 1,641 feet in length, 20 feet in height, and located along the ROW would reduce noise levels by at least 5 dB(A) for 23 benefited receptors and meet the noise reduction design goal of 7 dB(A) for at least one of those receptors. With a total area of abatement of 32,820 square feet or 1,427 square feet per benefited receptor, the barrier would be cost reasonable. Therefore, Barrier B02 is considered acoustically feasible and cost effective.

Barrier B03 and B05-1 have portions of each respective barrier on structure. As described below, under these conditions, Barrier O3 and Barrier O5-1 would not be feasible nor reasonable with a 10-foot barrier limitation in the on-structure portion. The barrier height for Barrier B03 would need to be 17 feet and Barrier O5-1 would need to be 16 feet. Light weight material should be considered in the sections that are on structure.

Barrier B03: R-163 to R-171, R-179, R-181, R-184 to R-186, R-189, R-190, R-192, R-194, R-197, R-199, R-203 to R-205, R-210, R-213 to R-216, R-218, R-221, R-223, R-224, R-227, R-228, R-230, R-233 to R-

236, R-238 to R-240, R-247 to R-315, R-317 to R-320, R-322 to R-325, R-327 to R-330, R-332 to R-334, R-337 to R-349, R-351 to R-359, R-362, R-363, R-365 to R-367, R-369 to R-372, R-375 to R-379, R-381, R-383 to R-385, R-388, R-391 to R-397, R-400 to R403, R-405, R-407 to R-410, R-413 to R-416, R-424 to R-428, R-430 to R-434, R-436, and R-443 (Figure B-6 and Figure B-7) - These receivers represent a total of 199 impacted residences at the Ladera Prosper neighborhood along the Brown and Gold alternatives. Based on preliminary calculations, a noise barrier 3,108 feet in length, 17 feet in height, and located along the ROW would reduce noise levels by at least 5 dB(A) for 36 benefited receptors and meet the noise reduction design goal of 7 dB(A) for at least one of those receptors. With a total area of abatement of 52,836 square feet or 1,468 square feet per benefited receptor, the barrier would be cost reasonable. Therefore, Barrier B03 is considered acoustically feasible and cost effective.

Barrier B05-1: R-448, R-450 to R-452, R-457, R-463, and R-464 (Figure B-6, Figure B-7 and Figure B-8) - These receivers represent a total of 132 equivalent dwelling units at ManeGait along the Brown and Gold alternatives. Based on preliminary calculations, a noise barrier 2,155 feet in length, 16 feet in height, and located along the ROW would reduce noise levels by at least 5 dB(A) for 52 benefited dwelling units and meet the noise reduction design goal of 7 dB(A) for at least one of those dwelling units. With a total area of abatement of 34,480 square feet or 663 square feet per benefited dwelling unit, the barrier would be cost reasonable. Therefore, Barrier B05-1 is considered acoustically feasible and cost effective. Since Barrier B05-1 is constructed on structure and a barrier height exceeding 10 feet is proposed, light weight material should be considered for this barrier to ensure the structural viability of the barrier.

Segment C

Segment C serves as a portion of the Blue and Brown alternatives. Segment C begins at SH 5 extending in a southeasterly direction across the Dallas Area Transit (DART) rail line and the East Fork Trinity River, then shifts to a more southerly direction east of and parallel to the East Fork Trinity River to connect to existing US 380 near FM 1827.

Results

Table 8 provides of summary of the traffic noise impacts for Segment C according to evaluated land-use receptors.

Table 8. Summary of Traffic Noise Impacts for Segment C

NAC	RECEPTORS	IMPACTS
A	0	0
B	104	16
C	2	1
D	0	0
E	0	0
Total	106	17

Existing and predicted traffic noise levels for Segment C were modeled at receiver locations listed in Table 9 that represent the land use activity areas adjacent to the proposed project that might be impacted by traffic noise and potentially benefit from feasible and reasonable noise abatement.

Traffic Noise Analysis Report

Table 9. Segment C Traffic Noise Levels dB(A) Leq

Segment C Representative Receiver	Figure	NAC Category	NAC Level	Existing	Predicted 2050	Change (+/-)	Noise Impact (Yes/No)
R-1384	Figure C-2	B-Residential	67	52	58	6	No
R-1386	Figure C-2	B-Residential	67	52	58	6	No
R-1388	Figure C-2	B-Residential	67	52	57	5	No
R-1389	Figure C-2	B-Residential	67	52	57	5	No
R-1390	Figure C-2	B-Residential	67	52	57	5	No
R-1391	Figure C-2	B-Residential	67	52	56	4	No
R-1392	Figure C-2	B-Residential	67	52	56	4	No
R-1393	Figure C-2	B-Residential	67	52	58	6	No
R-1394	Figure C-2	B-Residential	67	52	59	7	No
R-1395	Figure C-2	B-Residential	67	52	58	6	No
R-1396	Figure C-2	B-Residential	67	52	55	3	No
R-1397	Figure C-2	B-Residential	67	52	56	4	No
R-1398	Figure C-2	B-Residential	67	52	55	3	No
R-1399	Figure C-2	B-Residential	67	52	56	4	No
R-1400	Figure C-2	B-Residential	67	52	55	3	No
R-1401	Figure C-2	B-Residential	67	52	55	3	No
R-1402	Figure C-2	B-Residential	67	52	55	3	No
R-1403	Figure C-2	B-Residential	67	52	58	6	No
R-1404	Figure C-2	B-Residential	67	52	55	3	No
R-1405	Figure C-2	B-Residential	67	52	55	3	No
R-1406	Figure C-2	B-Residential	67	52	55	3	No
R-1407	Figure C-2	B-Residential	67	52	57	5	No
R-1408	Figure C-2	B-Residential	67	52	55	3	No
R-1409	Figure C-2	B-Residential	67	52	58	6	No
R-1410	Figure C-2	B-Residential	67	52	58	6	No
R-1411	Figure C-2	B-Residential	67	52	57	5	No
R-1412	Figure C-2	B-Residential	67	52	55	3	No
R-1413	Figure C-2	B-Residential	67	52	59	7	No
R-1414	Figure C-2	B-Residential	67	52	54	2	No
R-1415	Figure C-2	B-Residential	67	52	57	5	No
R-1416	Figure C-2	B-Residential	67	52	58	6	No
R-1417	Figure C-2	B-Residential	67	52	55	3	No
R-1418	Figure C-2	B-Residential	67	52	57	5	No
R-1419	Figure C-2	B-Residential	67	52	58	6	No
R-1420	Figure C-2	B-Residential	67	52	54	2	No
R-1421	Figure C-2	B-Residential	67	52	57	5	No
R-1422	Figure C-2	B-Residential	67	52	55	3	No
R-1423	Figure C-2	B-Residential	67	52	54	2	No
R-1424	Figure C-2	B-Residential	67	52	57	5	No

Traffic Noise Analysis Report

Table 9. Segment C Traffic Noise Levels dB(A) Leq

Segment C Representative Receiver	Figure	NAC Category	NAC Level	Existing	Predicted 2050	Change (+/-)	Noise Impact (Yes/No)
R-1425	Figure C-2	B-Residential	67	52	54	2	No
R-1426	Figure C-2	B-Residential	67	52	53	1	No
R-1427	Figure C-2	B-Residential	67	52	55	3	No
R-1428	Figure C-2	B-Residential	67	52	54	2	No
R-1429	Figure C-2	B-Residential	67	52	55	3	No
R-1431	Figure C-4	B-Residential	67	52	67	15	Yes
R-1432	Figure C-5	B-Residential	67	52	68	16	Yes
R-1433	Figure C-5	B-Residential	67	52	68	16	Yes
R-1434	Figure C-11	C-Park	67	67	52	-15	No
R-1436	Figure C-8	B-Residential	67	57	59	2	No
R-1437	Figure C-4	B-Residential	67	52	58	6	No
R-1438	Figure C-10	B-Residential	67	60	59	-1	No
R-1439	Figure C-9	B-Residential	67	51	61	10	No
R-1440	Figure C-10	B-Residential	67	60	60	0	No
R-1441	Figure C-10	B-Residential	67	60	57	-3	No
R-1442	Figure C-9	B-Residential	67	55	65	10	No
R-1443	Figure C-10	B-Residential	67	51	58	7	No
R-1444	Figure C-5	B-Residential	67	52	61	9	No
R-1445	Figure C-10	B-Residential	67	50	64	14	Yes
R-1446	Figure C-10	B-Residential	67	60	61	1	No
R-1447	Figure C-10	B-Residential	67	60	62	2	No
R-1448	Figure C-10	B-Residential	67	60	64	4	No
R-1449	Figure C-7	B-Residential	67	57	67	10	Yes
R-1450	Figure C-6	B-Residential	67	57	64	7	No
R-1451	Figure C-10	B-Residential	67	55	66	11	Yes
R-1452	Figure C-7	B-Residential	67	57	60	3	No
R-1453	Figure C-7	B-Residential	67	57	61	4	No
R-1454	Figure C-7	B-Residential	67	57	59	2	No
R-1455	Figure C-7	B-Residential	67	57	60	3	No
R-1456	Figure C-10	B-Residential	67	56	63	7	No
R-1457	Figure C-10	B-Residential	67	60	67	7	Yes
R-1458	Figure C-10	B-Residential	67	60	61	1	No
R-1459	Figure C-13	B-Residential	67	54	59	5	No
R-1461	Figure C-11	B-Residential	67	60	60	0	No
R-1463	Figure C-11	B-Residential	67	60	59	-1	No
R-1465	Figure C-11	B-Residential	67	60	60	0	No
R-1467	Figure C-12	B-Residential	67	60	60	0	No
R-1469	Figure C-12	B-Residential	67	51	59	8	No
R-1471	Figure C-12	B-Residential	67	51	58	7	No

Table 9. Segment C Traffic Noise Levels dB(A) Leq

Segment C Representative Receiver	Figure	NAC Category	NAC Level	Existing	Predicted 2050	Change (+/-)	Noise Impact (Yes/No)
R-1473	Figure C-12	B-Residential	67	55	62	7	No
R-1475	Figure C-12	B-Residential	67	58	62	4	No
R-1477	Figure C-12	B-Residential	67	59	65	6	No
R-1479	Figure C-12	B-Residential	67	55	62	7	No
R-1481	Figure C-12	B-Residential	67	56	60	4	No
R-1483	Figure C-12	B-Residential	67	55	61	6	No
R-1485	Figure C-12	B-Residential	67	55	59	4	No
R-1487	Figure C-12	B-Residential	67	52	58	6	No
R-1489	Figure C-12	B-Residential	67	51	55	4	No
R-1491	Figure C-13	B-Residential	67	58	68	10	Yes
R-1493	Figure C-13	B-Residential	67	53	60	7	No
R-1495	Figure C-13	B-Residential	67	59	68	9	Yes
R-1497	Figure C-13	B-Residential	67	58	65	7	No
R-1499	Figure C-13	B-Residential	67	52	59	7	No
R-1501	Figure C-13	B-Residential	67	51	59	8	No
R-1503	Figure C-13	B-Residential	67	56	63	7	No
R-1505	Figure C-13	B-Residential	67	53	59	6	No
R-1507	Figure C-13	B-Residential	67	53	59	6	No
R-1509	Figure C-14	B-Residential	67	53	61	8	No
R-1511	Figure C-14	B-Residential	67	58	66	8	Yes
R-1513	Figure C-14	B-Residential	67	58	66	8	Yes
R-1515	Figure C-14	B-Residential	67	58	66	8	Yes
R-1517	Figure C-14	B-Residential	67	59	67	8	Yes
R-1519	Figure C-14	B-Residential	67	61	69	8	Yes
R-1521	Figure C-14	C-Institutional	67	66	75	9	Yes
R-1522	Figure C-14	B-Residential	67	62	70	8	Yes
R-1524	Figure C-14	B-Residential	67	53	61	8	No
R-1526	Figure C-14	B-Residential	67	61	68	7	Yes

Abbreviations: NAC, Noise Abatement Criteria; dB(A), A-weighted decibel; Leq, average/equivalent sound level. Existing noise levels in **BOLD** were determined based on nearby ambient measurements. These receptors are not near any existing roadways that produce enough traffic noise to calculate existing noise levels. Data sheets are included in Attachments C and D.

As indicated in Table 9, the proposed project would result in a traffic noise impact at one or more representative receiver locations.

Noise abatement measures were considered for each location with predicted noise impacts.

Abatement Analysis

Noise barriers would not be feasible and reasonable for any of the following impacted receptors, and therefore, are not proposed for incorporation into the project:

R-1431, R-1432, R-1433, R-1445, R-1449, R-1451, and R-1457- These receptors are separate, isolated residences, which are not associated with a neighborhood or subdivision. Because a noise abatement measure must potentially benefit a minimum of two impacted receptors, noise abatement for these locations is not feasible.

R-1491, R-1495, R-1511, R-1513, R-1515, R-1517, R-1519, R-1521, R-1522, and R-1526 - These receivers represent a group of 10 residences with driveways that connect to the frontage road. A continuous noise barrier would restrict access to these residences. Gaps in the noise barrier would satisfy access requirements, but the resulting non-continuous wall segments would not be sufficient to achieve the minimum, feasible reduction of 5 dB(A) for a majority of impacted receptors or the noise reduction design goal of 7 dB(A).

Segment D

Segment D serves as a portion of the Purple and Gold alternatives. Segment D also begins at SH 5 extending in a southerly direction across the DART rail line and the East Fork Trinity River and continues in a southerly direction west of and parallel to the East Fork Trinity River connecting to US 380 near Airport Drive and following existing US 380 to the east to FM 1827.

Results

Table 10 provides a summary of the traffic noise impacts for Segment D according to evaluated land-use receptors.

Table 10. Summary of Traffic Noise Impacts for Segment D

NAC	RECEPTORS	IMPACTS
A	0	0
B	40	14
C	7	2
D	0	0
E	0	0
Total	47	16

Existing and predicted traffic noise levels for Segment D were modeled at receiver locations listed in Table 11 that represent the land use activity areas adjacent to the proposed project that might be impacted by traffic noise and potentially benefit from feasible and reasonable noise abatement.

Table 11. Segment D Traffic Noise Levels dB(A) Leq

Segment D Representative Receiver	Figure	NAC Category	NAC Level	Existing	Predicted 2050	Change (+/-)	Noise Impact (Yes/No)
R-1375	Figure D-7	C-Playgrounds	67	47	54	7	No

Traffic Noise Analysis Report

Table 11. Segment D Traffic Noise Levels dB(A) Leq

Segment D Representative Receiver	Figure	NAC Category	NAC Level	Existing	Predicted 2050	Change (+/-)	Noise Impact (Yes/No)
R-1376	Figure D-7	C-Playgrounds	67	47	54	7	No
R-1377	Figure D-7	C-Picnic areas	67	47	55	8	No
R-1378	Figure D-7	C-Basketball Court	67	47	55	8	No
R-1379	Figure D-5	C-Institutional	67	50	53	3	No
R-1380	Figure D-5	B-Residential	67	50	62	12	Yes
R-1381	Figure D-5	B-Residential	67	50	63	13	Yes
R-1382	Figure D-5	B-Residential	67	50	63	13	Yes
R-1383	Figure D-5	B-Residential	67	50	62	12	Yes
R-1385	Figure D-5	B-Residential	67	50	62	12	Yes
R-1387	Figure D-5	B-Residential	67	51	64	13	Yes
R-1430	Figure D-7	C-Park	67	61	67	6	Yes
R-1435	Figure D-8	C-Park	67	63	68	5	Yes
R-1459	Figure D-10	B-Residential	67	54	59	5	No
R-1461	Figure D-9	B-Residential	67	60	55	-5	No
R-1463	Figure D-9	B-Residential	67	60	55	-5	No
R-1465	Figure D-9	B-Residential	67	60	56	-4	No
R-1467	Figure D-9	B-Residential	67	60	56	-4	No
R-1469	Figure D-9	B-Residential	67	51	56	5	No
R-1471	Figure D-9	B-Residential	67	51	56	5	No
R-1473	Figure D-9	B-Residential	67	55	60	5	No
R-1475	Figure D-9	B-Residential	67	58	61	3	No
R-1477	Figure D-9	B-Residential	67	59	63	4	No
R-1479	Figure D-9	B-Residential	67	55	60	5	No
R-1481	Figure D-9	B-Residential	67	56	60	4	No
R-1483	Figure D-9	B-Residential	67	55	60	5	No
R-1485	Figure D-9	B-Residential	67	55	58	3	No
R-1487	Figure D-9	B-Residential	67	51	57	6	No
R-1489	Figure D-9	B-Residential	67	51	54	3	No
R-1491	Figure D-11	B-Residential	67	58	69	11	Yes
R-1493	Figure D-11	B-Residential	67	53	60	7	No
R-1495	Figure D-11	B-Residential	67	59	69	10	Yes
R-1497	Figure D-11	B-Residential	67	58	66	8	Yes
R-1499	Figure D-11	B-Residential	67	52	60	8	No
R-1501	Figure D-11	B-Residential	67	51	58	7	No
R-1503	Figure D-11	B-Residential	67	56	63	7	No
R-1505	Figure D-11	B-Residential	67	53	60	7	No
R-1507	Figure D-11	B-Residential	67	52	60	8	No
R-1509	Figure D-11	B-Residential	67	53	61	8	No

Table 11. Segment D Traffic Noise Levels dB(A) Leq

Segment D Representative Receiver	Figure	NAC Category	NAC Level	Existing	Predicted 2050	Change (+/-)	Noise Impact (Yes/No)
R-1511	Figure D-11	B-Residential	67	58	65	7	No
R-1513	Figure D-11	B-Residential	67	58	65	7	No
R-1515	Figure D-11	B-Residential	67	58	66	8	Yes
R-1517	Figure D-11	B-Residential	67	58	66	8	Yes
R-1519	Figure D-11	B-Residential	67	61	68	7	Yes
R-1522	Figure D-11	B-Residential	67	62	69	7	Yes
R-1524	Figure D-11	B-Residential	67	53	61	8	No
R-1526	Figure D-11	B-Residential	67	62	68	6	Yes

Abbreviations: NAC, Noise Abatement Criteria; dB(A), A-weighted decibel; Leq, average/equivalent sound level. Existing noise levels in **BOLD** were determined based on nearby ambient measurements. These receptors are not near any existing roadways that produce enough traffic noise to calculate existing noise levels. Data sheets are included in Attachments C and D.

As indicated in Table 11, the proposed project would result in a traffic noise impact at one or more representative receiver locations.

Noise abatement measures were considered for each location with predicted noise impacts.

Abatement Analysis

Noise barriers would not be feasible and reasonable for any of the following impacted receptors, and therefore, are not proposed for incorporation into the project:

R-1519, R-1522, and R-1526- These receivers represent a group of 3 residences with driveways that connect to the frontage road. A continuous noise barrier would restrict access to these residences. Gaps in the noise barrier would satisfy access requirements, but the resulting non-continuous wall segments would not be sufficient to achieve the minimum, feasible reduction of 5 dB(A) for a majority of impacted receptors or the noise reduction design goal of 7 dB(A).

Barrier D01: R-1380 to R-1383, R-1385, and R-1387 (Figure D-5 and Figure D-6) - These receivers represent a total of 6 impacted residences in the Woodlawn neighborhood along the Purple and Gold alternatives. A continuous noise barrier 16 feet in height and approximately 3,206 feet in length was modeled along the frontage road. This barrier would achieve the minimum feasible reduction of 5 dB(A) for six receptors while meeting the 7 dB(A) noise reduction design goal at one of those receptors. However, the square footage of abatement (51,296 square feet or 8,549 square feet per benefited receptor) would exceed the reasonable, cost-reasonableness criterion of 1,500 square feet per benefited receptor.

Barrier D02: R-1491, R-1495, R-1497, R-1515, and R-1517 (Figure D-10 and Figure D-11)- These receivers represent a total of 5 impacted residences between ML 2105+00 and ML 2119+00 and 2119+00 to 2130+00 along the Purple and Gold alternatives. A continuous noise barrier 16 feet in height and approximately 2,687 feet in length was modeled along the mainline. This barrier would achieve the minimum feasible reduction of 5 dB(A) for four receptors while meeting the 7 dB(A) noise reduction design goal at one of those receptors. However, the square footage of abatement (42,992 square feet or 10,748 square feet per benefited receptor) would exceed the reasonable, cost-reasonableness criterion of 1,500 square feet per benefited receptor.

Barrier D03: R-1430 and R-1435 (Figure D-7, Figure D-8, Figure D-9 and Figure D-10)- These receivers represent a total of 124 equivalent dwelling units in City Parkland along the Purple and Gold alternatives. Based on preliminary calculations, a noise barrier 5,445 feet in length, 20 feet in height, and located along the ROW would not be sufficient to achieve the minimum, feasible reduction of 5 dB(A) for a majority of impacted receptors or the noise reduction design goal of 7 dB(A).

Segment E

Segment E serves as a portion of all four Build alternatives. Segment E extends roughly along the alignment of existing Bloomdale Road through north McKinney beginning at the proposed intersection of Ridge Road and Bloomdale Road on the west and SH 5 on the east. This segment includes a new interchange connection with US 75 and SH 5. Segment E is a common segment in all the new location Build alternatives.

Results

Table 12 provides a summary of the traffic noise impacts for Segment E according to evaluated land-use receptors.

Table 12. Summary of Traffic Noise Impacts for Segment E

NAC	RECEPTORS	IMPACTS
A	0	0
B	483	70
C	4	3
D	0	0
E	1	0
Total	489	73

Existing and predicted traffic noise levels for Segment E were modeled at receiver locations listed in Table 13 that represent the land use activity areas adjacent to the proposed project that might be impacted by traffic noise and potentially benefit from feasible and reasonable noise abatement.

Table 13. Segment E Traffic Noise Levels dB(A) Leq

Segment E Representative Receiver	Figure	NAC Category	NAC Level	Existing	Predicted 2050	Change (+/-)	Noise Impact (Yes/No)
R-859	Figure E-1	B-Residential	67	55	49	-6	No
R-861	Figure E-1	B-Residential	67	55	50	-5	No
R-862	Figure E-1	B-Residential	67	55	50	-5	No
R-864	Figure E-1	B-Residential	67	55	50	-5	No
R-865	Figure E-1	B-Residential	67	50	52	2	No
R-866	Figure E-1	B-Residential	67	55	50	-5	No
R-868	Figure E-1	B-Residential	67	55	53	-2	No
R-869	Figure E-1	B-Residential	67	55	50	-5	No
R-871	Figure E-1	B-Residential	67	55	53	-2	No

Traffic Noise Analysis Report

Table 13. Segment E Traffic Noise Levels dB(A) Leq

Segment E Representative Receiver	Figure	NAC Category	NAC Level	Existing	Predicted 2050	Change (+/-)	Noise Impact (Yes/No)
R-872	Figure E-1	B-Residential	67	55	53	-2	No
R-874	Figure E-1	B-Residential	67	55	51	-4	No
R-875	Figure E-1	B-Residential	67	55	53	-2	No
R-876	Figure E-1	B-Residential	67	55	50	-5	No
R-878	Figure E-1	B-Residential	67	55	50	-5	No
R-879	Figure E-1	B-Residential	67	55	50	-5	No
R-880	Figure E-1	B-Residential	67	55	50	-5	No
R-882	Figure E-1	B-Residential	67	55	50	-5	No
R-883	Figure E-1	B-Residential	67	55	50	-5	No
R-885	Figure E-1	B-Residential	67	55	50	-5	No
R-886	Figure E-1	B-Residential	67	55	50	-5	No
R-888	Figure E-1	B-Residential	67	55	49	-6	No
R-889	Figure E-1	B-Residential	67	55	49	-6	No
R-890	Figure E-1	B-Residential	67	55	54	-1	No
R-891	Figure E-1	B-Residential	67	55	49	-6	No
R-892	Figure E-1	B-Residential	67	55	52	-3	No
R-893	Figure E-1	B-Residential	67	55	48	-7	No
R-896	Figure E-1	B-Residential	67	55	55	0	No
R-897	Figure E-1	B-Residential	67	55	51	-4	No
R-898	Figure E-1	B-Residential	67	55	48	-7	No
R-899	Figure E-1	B-Residential	67	55	53	-2	No
R-902	Figure E-1	B-Residential	67	55	56	1	No
R-903	Figure E-1	B-Residential	67	55	52	-3	No
R-904	Figure E-1	B-Residential	67	55	51	-4	No
R-905	Figure E-1	B-Residential	67	55	53	-2	No
R-906	Figure E-1	B-Residential	67	55	49	-6	No
R-907	Figure E-1	B-Residential	67	55	51	-4	No
R-908	Figure E-1	B-Residential	67	55	56	1	No
R-909	Figure E-1	B-Residential	67	55	52	-3	No
R-910	Figure E-1	B-Residential	67	55	53	-2	No
R-911	Figure E-1	B-Residential	67	55	54	-1	No
R-914	Figure E-1	B-Residential	67	55	51	-4	No
R-915	Figure E-1	B-Residential	67	55	50	-5	No
R-916	Figure E-1	B-Residential	67	55	57	2	No
R-917	Figure E-1	B-Residential	67	55	52	-3	No
R-920	Figure E-1	B-Residential	67	55	53	-2	No
R-921	Figure E-1	B-Residential	67	55	55	0	No
R-922	Figure E-1	B-Residential	67	55	50	-5	No
R-923	Figure E-1	B-Residential	67	55	51	-4	No

Traffic Noise Analysis Report

Table 13. Segment E Traffic Noise Levels dB(A) Leq

Segment E Representative Receiver	Figure	NAC Category	NAC Level	Existing	Predicted 2050	Change (+/-)	Noise Impact (Yes/No)
R-924	Figure E-1	B-Residential	67	55	58	3	No
R-926	Figure E-1	B-Residential	67	55	52	-3	No
R-927	Figure E-1	B-Residential	67	55	54	-1	No
R-928	Figure E-1	B-Residential	67	55	55	0	No
R-929	Figure E-1	B-Residential	67	55	50	-5	No
R-930	Figure E-1	B-Residential	67	55	52	-3	No
R-931	Figure E-1	B-Residential	67	55	58	3	No
R-932	Figure E-1	B-Residential	67	55	53	-2	No
R-933	Figure E-1	B-Residential	67	55	54	-1	No
R-934	Figure E-1	B-Residential	67	55	56	1	No
R-935	Figure E-1	B-Residential	67	55	50	-5	No
R-936	Figure E-1	B-Residential	67	55	52	-3	No
R-937	Figure E-1	B-Residential	67	55	59	4	No
R-938	Figure E-1	B-Residential	67	55	53	-2	No
R-940	Figure E-1	B-Residential	67	55	55	0	No
R-941	Figure E-1	B-Residential	67	55	56	1	No
R-942	Figure E-1	B-Residential	67	55	51	-4	No
R-943	Figure E-1	B-Residential	67	55	52	-3	No
R-944	Figure E-1	B-Residential	67	55	59	4	No
R-945	Figure E-1	B-Residential	67	55	53	-2	No
R-947	Figure E-1	B-Residential	67	55	51	-4	No
R-949	Figure E-1	B-Residential	67	55	54	-1	No
R-950	Figure E-1	B-Residential	67	55	53	-2	No
R-951	Figure E-1	B-Residential	67	55	60	5	No
R-952	Figure E-1	B-Residential	67	55	48	-7	No
R-953	Figure E-1	B-Residential	67	55	49	-6	No
R-954	Figure E-1	B-Residential	67	55	53	-2	No
R-955	Figure E-1	B-Residential	67	55	49	-6	No
R-956	Figure E-1	B-Residential	67	55	54	-1	No
R-957	Figure E-1	B-Residential	67	55	49	-6	No
R-958	Figure E-1	B-Residential	67	55	49	-6	No
R-959	Figure E-1	B-Residential	67	55	49	-6	No
R-960	Figure E-1	B-Residential	67	55	52	-3	No
R-961	Figure E-1	B-Residential	67	55	51	-4	No
R-962	Figure E-1	B-Residential	67	55	51	-4	No
R-963	Figure E-1	B-Residential	67	55	50	-5	No
R-964	Figure E-1	B-Residential	67	55	50	-5	No
R-965	Figure E-1	B-Residential	67	55	56	1	No
R-966	Figure E-1	B-Residential	67	55	57	2	No

Traffic Noise Analysis Report

Table 13. Segment E Traffic Noise Levels dB(A) Leq

Segment E Representative Receiver	Figure	NAC Category	NAC Level	Existing	Predicted 2050	Change (+/-)	Noise Impact (Yes/No)
R-967	Figure E-1	B-Residential	67	55	58	3	No
R-968	Figure E-1	B-Residential	67	55	57	2	No
R-969	Figure E-1	B-Residential	67	55	60	5	No
R-970	Figure E-1	B-Residential	67	55	59	4	No
R-972	Figure E-1	B-Residential	67	55	54	-1	No
R-973	Figure E-1	B-Residential	67	55	55	0	No
R-974	Figure E-1	B-Residential	67	55	48	-7	No
R-976	Figure E-1	B-Residential	67	55	48	-7	No
R-977	Figure E-1	B-Residential	67	55	50	-5	No
R-978	Figure E-1	B-Residential	67	55	50	-5	No
R-979	Figure E-1	B-Residential	67	55	50	-5	No
R-980	Figure E-1	B-Residential	67	55	50	-5	No
R-981	Figure E-1	B-Residential	67	55	49	-6	No
R-982	Figure E-1	B-Residential	67	55	49	-6	No
R-983	Figure E-1	B-Residential	67	55	54	-1	No
R-984	Figure E-1	B-Residential	67	55	54	-1	No
R-985	Figure E-1	B-Residential	67	55	52	-3	No
R-986	Figure E-1	B-Residential	67	55	55	0	No
R-987	Figure E-1	B-Residential	67	55	53	-2	No
R-988	Figure E-1	B-Residential	67	55	55	0	No
R-989	Figure E-1	B-Residential	67	55	56	1	No
R-990	Figure E-1	B-Residential	67	55	49	-6	No
R-991	Figure E-1	B-Residential	67	55	56	1	No
R-992	Figure E-1	B-Residential	67	55	57	2	No
R-993	Figure E-1	E-Commercial	72	55	63	8	No
R-994	Figure E-2	B-Residential	67	55	56	1	No
R-995	Figure E-2	B-Residential	67	55	54	-1	No
R-996	Figure E-2	B-Residential	67	55	53	-2	No
R-997	Figure E-2	B-Residential	67	55	52	-3	No
R-998	Figure E-2	B-Residential	67	55	52	-3	No
R-999	Figure E-2	B-Residential	67	55	58	3	No
R-1000	Figure E-2	B-Residential	67	55	56	1	No
R-1001	Figure E-2	B-Residential	67	55	54	-1	No
R-1002	Figure E-2	B-Residential	67	55	53	-2	No
R-1003	Figure E-1	B-Residential	67	55	56	1	No
R-1004	Figure E-2	B-Residential	67	55	56	1	No
R-1005	Figure E-2	B-Residential	67	55	54	-1	No
R-1006	Figure E-2	B-Residential	67	55	52	-3	No
R-1007	Figure E-2	B-Residential	67	55	56	1	No

Traffic Noise Analysis Report

Table 13. Segment E Traffic Noise Levels dB(A) Leq

Segment E Representative Receiver	Figure	NAC Category	NAC Level	Existing	Predicted 2050	Change (+/-)	Noise Impact (Yes/No)
R-1008	Figure E-2	B-Residential	67	55	53	-2	No
R-1009	Figure E-2	B-Residential	67	55	52	-3	No
R-1010	Figure E-2	B-Residential	67	55	55	0	No
R-1011	Figure E-2	B-Residential	67	55	53	-2	No
R-1012	Figure E-2	B-Residential	67	55	52	-3	No
R-1013	Figure E-2	B-Residential	67	55	55	0	No
R-1014	Figure E-2	B-Residential	67	55	53	-2	No
R-1015	Figure E-2	B-Residential	67	55	55	0	No
R-1016	Figure E-2	B-Residential	67	55	60	5	No
R-1017	Figure E-2	B-Residential	67	55	60	5	No
R-1018	Figure E-2	B-Residential	67	55	60	5	No
R-1019	Figure E-2	B-Residential	67	55	59	4	No
R-1020	Figure E-2	B-Residential	67	55	58	3	No
R-1021	Figure E-2	B-Residential	67	55	58	3	No
R-1022	Figure E-2	B-Residential	67	55	57	2	No
R-1023	Figure E-2	B-Residential	67	55	60	5	No
R-1024	Figure E-2	B-Residential	67	55	62	7	No
R-1025	Figure E-2	B-Residential	67	55	61	6	No
R-1026	Figure E-2	B-Residential	67	55	59	4	No
R-1027	Figure E-2	B-Residential	67	55	62	7	No
R-1028	Figure E-2	B-Residential	67	55	61	6	No
R-1029	Figure E-2	B-Residential	67	55	60	5	No
R-1030	Figure E-1	B-Residential	67	55	59	4	No
R-1031	Figure E-2	B-Residential	67	55	62	7	No
R-1032	Figure E-2	B-Residential	67	55	61	6	No
R-1033	Figure E-2	B-Residential	67	55	60	5	No
R-1034	Figure E-2	B-Residential	67	55	61	6	No
R-1035	Figure E-2	B-Residential	67	55	61	6	No
R-1036	Figure E-2	B-Residential	67	55	60	5	No
R-1037	Figure E-2	B-Residential	67	55	61	6	No
R-1038	Figure E-2	B-Residential	67	55	61	6	No
R-1039	Figure E-2	B-Residential	67	55	60	5	No
R-1040	Figure E-2	B-Residential	67	55	60	5	No
R-1041	Figure E-2	B-Residential	67	55	61	6	No
R-1042	Figure E-2	B-Residential	67	55	60	5	No
R-1043	Figure E-2	B-Residential	67	55	60	5	No
R-1044	Figure E-2	B-Residential	67	55	61	6	No
R-1045	Figure E-2	B-Residential	67	55	60	5	No
R-1046	Figure E-3	B-Residential	67	55	60	5	No

Traffic Noise Analysis Report

Table 13. Segment E Traffic Noise Levels dB(A) Leq

Segment E Representative Receiver	Figure	NAC Category	NAC Level	Existing	Predicted 2050	Change (+/-)	Noise Impact (Yes/No)
R-1047	Figure E-3	B-Residential	67	55	61	6	No
R-1048	Figure E-3	B-Residential	67	55	59	4	No
R-1049	Figure E-3	B-Residential	67	55	59	4	No
R-1050	Figure E-3	B-Residential	67	55	59	4	No
R-1051	Figure E-3	B-Residential	67	55	58	3	No
R-1052	Figure E-3	B-Residential	67	55	58	3	No
R-1053	Figure E-3	B-Residential	67	55	57	2	No
R-1054	Figure E-3	B-Residential	67	55	60	5	No
R-1055	Figure E-3	B-Residential	67	55	58	3	No
R-1056	Figure E-3	B-Residential	67	55	57	2	No
R-1057	Figure E-3	B-Residential	67	57	61	4	No
R-1058	Figure E-3	B-Residential	67	55	59	4	No
R-1059	Figure E-3	B-Residential	67	55	58	3	No
R-1060	Figure E-3	B-Residential	67	55	59	4	No
R-1061	Figure E-3	B-Residential	67	58	61	3	No
R-1062	Figure E-3	B-Residential	67	55	58	3	No
R-1063	Figure E-3	B-Residential	67	55	59	4	No
R-1064	Figure E-3	B-Residential	67	58	59	1	No
R-1065	Figure E-3	B-Residential	67	55	57	2	No
R-1066	Figure E-3	B-Residential	67	55	59	4	No
R-1067	Figure E-3	B-Residential	67	58	60	2	No
R-1068	Figure E-3	B-Residential	67	55	58	3	No
R-1069	Figure E-3	B-Residential	67	55	59	4	No
R-1070	Figure E-3	B-Residential	67	58	59	1	No
R-1071	Figure E-3	B-Residential	67	55	57	2	No
R-1072	Figure E-3	B-Residential	67	55	59	4	No
R-1073	Figure E-3	B-Residential	67	58	59	1	No
R-1074	Figure E-3	B-Residential	67	55	56	1	No
R-1075	Figure E-3	B-Residential	67	55	59	4	No
R-1076	Figure E-3	B-Residential	67	57	59	2	No
R-1077	Figure E-3	B-Residential	67	55	56	1	No
R-1078	Figure E-3	B-Residential	67	55	60	5	No
R-1079	Figure E-3	B-Residential	67	55	59	4	No
R-1080	Figure E-3	B-Residential	67	57	58	1	No
R-1081	Figure E-3	B-Residential	67	55	56	1	No
R-1082	Figure E-3	B-Residential	67	55	59	4	No
R-1083	Figure E-3	B-Residential	67	58	58	0	No
R-1084	Figure E-3	B-Residential	67	55	56	1	No
R-1085	Figure E-3	B-Residential	67	55	59	4	No

Traffic Noise Analysis Report

Table 13. Segment E Traffic Noise Levels dB(A) Leq

Segment E Representative Receiver	Figure	NAC Category	NAC Level	Existing	Predicted 2050	Change (+/-)	Noise Impact (Yes/No)
R-1086	Figure E-3	B-Residential	67	58	58	0	No
R-1087	Figure E-3	B-Residential	67	55	56	1	No
R-1088	Figure E-3	B-Residential	67	55	59	4	No
R-1089	Figure E-3	B-Residential	67	58	58	0	No
R-1090	Figure E-3	B-Residential	67	55	55	0	No
R-1091	Figure E-3	B-Residential	67	55	60	5	No
R-1092	Figure E-3	B-Residential	67	58	58	0	No
R-1093	Figure E-3	B-Residential	67	55	55	0	No
R-1094	Figure E-3	B-Residential	67	55	60	5	No
R-1095	Figure E-3	B-Residential	67	58	58	0	No
R-1096	Figure E-3	B-Residential	67	55	55	0	No
R-1097	Figure E-3	B-Residential	67	55	60	5	No
R-1098	Figure E-3	B-Residential	67	58	59	1	No
R-1099	Figure E-3	B-Residential	67	55	55	0	No
R-1100	Figure E-3	B-Residential	67	55	60	5	No
R-1101	Figure E-3	B-Residential	67	58	57	-1	No
R-1102	Figure E-3	B-Residential	67	55	55	0	No
R-1103	Figure E-3	B-Residential	67	55	60	5	No
R-1104	Figure E-3	B-Residential	67	58	57	-1	No
R-1105	Figure E-3	B-Residential	67	55	55	0	No
R-1106	Figure E-3	B-Residential	67	55	59	4	No
R-1107	Figure E-3	B-Residential	67	58	57	-1	No
R-1108	Figure E-3	B-Residential	67	55	55	0	No
R-1109	Figure E-3	B-Residential	67	55	59	4	No
R-1110	Figure E-3	B-Residential	67	58	57	-1	No
R-1111	Figure E-3	B-Residential	67	55	56	1	No
R-1112	Figure E-3	B-Residential	67	55	59	4	No
R-1113	Figure E-3	B-Residential	67	57	57	0	No
R-1114	Figure E-3	B-Residential	67	55	56	1	No
R-1115	Figure E-3	B-Residential	67	55	59	4	No
R-1116	Figure E-3	B-Residential	67	58	57	-1	No
R-1117	Figure E-3	B-Residential	67	55	56	1	No
R-1118	Figure E-3	B-Residential	67	55	60	5	No
R-1119	Figure E-3	B-Residential	67	58	58	0	No
R-1120	Figure E-3	B-Residential	67	55	56	1	No
R-1121	Figure E-3	B-Residential	67	56	59	3	No
R-1122	Figure E-3	B-Residential	67	60	58	-2	No
R-1123	Figure E-3	B-Residential	67	55	57	2	No
R-1124	Figure E-3	B-Residential	67	55	59	4	No

Traffic Noise Analysis Report

Table 13. Segment E Traffic Noise Levels dB(A) Leq

Segment E Representative Receiver	Figure	NAC Category	NAC Level	Existing	Predicted 2050	Change (+/-)	Noise Impact (Yes/No)
R-1125	Figure E-3	B-Residential	67	55	58	3	No
R-1126	Figure E-3	B-Residential	67	59	59	0	No
R-1127	Figure E-3	B-Residential	67	55	59	4	No
R-1128	Figure E-3	B-Residential	67	55	58	3	No
R-1129	Figure E-3	B-Residential	67	57	59	2	No
R-1130	Figure E-3	B-Residential	67	55	59	4	No
R-1131	Figure E-3	B-Residential	67	55	59	4	No
R-1132	Figure E-3	B-Residential	67	56	59	3	No
R-1133	Figure E-3	B-Residential	67	55	60	5	No
R-1134	Figure E-3	B-Residential	67	55	59	4	No
R-1135	Figure E-3	B-Residential	67	56	59	3	No
R-1136	Figure E-3	B-Residential	67	55	60	5	No
R-1137	Figure E-3	B-Residential	67	55	60	5	No
R-1139	Figure E-3	B-Residential	67	56	59	3	No
R-1140	Figure E-3	B-Residential	67	55	60	5	No
R-1141	Figure E-3	B-Residential	67	55	60	5	No
R-1142	Figure E-3	B-Residential	67	56	60	4	No
R-1143	Figure E-3	B-Residential	67	55	60	5	No
R-1144	Figure E-3	B-Residential	67	55	61	6	No
R-1145	Figure E-3	B-Residential	67	56	61	5	No
R-1146	Figure E-3	B-Residential	67	55	61	6	No
R-1147	Figure E-3	B-Residential	67	55	61	6	No
R-1148	Figure E-3	B-Residential	67	55	61	6	No
R-1149	Figure E-3	B-Residential	67	55	61	6	No
R-1150	Figure E-3	B-Residential	67	55	61	6	No
R-1151	Figure E-3	B-Residential	67	55	62	7	No
R-1152	Figure E-3	B-Residential	67	55	59	4	No
R-1153	Figure E-3	B-Residential	67	55	62	7	No
R-1154	Figure E-3	B-Residential	67	55	62	7	No
R-1155	Figure E-3	B-Residential	67	56	62	6	No
R-1156	Figure E-3	B-Residential	67	55	62	7	No
R-1157	Figure E-3	B-Residential	67	55	62	7	No
R-1158	Figure E-3	B-Residential	67	56	63	7	No
R-1159	Figure E-3	B-Residential	67	55	63	8	No
R-1160	Figure E-3	B-Residential	67	55	63	8	No
R-1161	Figure E-3	B-Residential	67	56	63	7	No
R-1162	Figure E-3	B-Residential	67	55	63	8	No
R-1163	Figure E-3	B-Residential	67	55	63	8	No
R-1164	Figure E-3	B-Residential	67	56	64	8	No

Traffic Noise Analysis Report

Table 13. Segment E Traffic Noise Levels dB(A) Leq

Segment E Representative Receiver	Figure	NAC Category	NAC Level	Existing	Predicted 2050	Change (+/-)	Noise Impact (Yes/No)
R-1165	Figure E-3	B-Residential	67	55	63	8	No
R-1166	Figure E-3	B-Residential	67	55	63	8	No
R-1167	Figure E-3	B-Residential	67	56	64	8	No
R-1168	Figure E-3	B-Residential	67	55	63	8	No
R-1169	Figure E-3	B-Residential	67	55	64	9	No
R-1170	Figure E-3	B-Residential	67	55	66	11	Yes
R-1171	Figure E-3	B-Residential	67	56	65	9	No
R-1172	Figure E-3	B-Residential	67	55	63	8	No
R-1173	Figure E-3	B-Residential	67	55	64	9	No
R-1174	Figure E-3	B-Residential	67	56	66	10	Yes
R-1175	Figure E-3	B-Residential	67	55	70	15	Yes
R-1176	Figure E-3	B-Residential	67	55	64	9	No
R-1177	Figure E-3	B-Residential	67	55	64	9	No
R-1178	Figure E-3	B-Residential	67	56	65	9	No
R-1179	Figure E-3	B-Residential	67	55	64	9	No
R-1180	Figure E-3	B-Residential	67	55	62	7	No
R-1181	Figure E-3	B-Residential	67	55	65	10	No
R-1182	Figure E-3	B-Residential	67	55	67	12	Yes
R-1183	Figure E-3	B-Residential	67	55	66	11	Yes
R-1184	Figure E-3	B-Residential	67	55	66	11	Yes
R-1185	Figure E-3	B-Residential	67	55	65	10	No
R-1186	Figure E-3	B-Residential	67	55	65	10	No
R-1187	Figure E-4	B-Residential	67	50	70	20	Yes
R-1188	Figure E-4	B-Residential	67	55	69	14	Yes
R-1189	Figure E-4	B-Residential	67	55	64	9	No
R-1190	Figure E-4	B-Residential	67	55	66	11	Yes
R-1191	Figure E-5	C-Park	67	35	55	20	Yes
R-1192	Figure E-6	B-Residential	67	55	51	-4	No
R-1193	Figure E-6	B-Residential	67	55	60	5	No
R-1194	Figure E-8	B-Residential	67	51	62	11	Yes
R-1195	Figure E-8	B-Residential	67	51	61	10	No
R-1196	Figure E-8	B-Residential	67	51	66	15	Yes
R-1197	Figure E-8	B-Residential	67	51	66	15	Yes
R-1198	Figure E-8	B-Residential	67	51	67	16	Yes
R-1199	Figure E-8	B-Residential	67	51	67	16	Yes
R-1200	Figure E-8	B-Residential	67	51	63	12	Yes
R-1201	Figure E-8	B-Residential	67	51	61	10	No
R-1202	Figure E-8	B-Residential	67	51	68	17	Yes
R-1203	Figure E-8	B-Residential	67	51	63	12	Yes

Traffic Noise Analysis Report

Table 13. Segment E Traffic Noise Levels dB(A) Leq

Segment E Representative Receiver	Figure	NAC Category	NAC Level	Existing	Predicted 2050	Change (+/-)	Noise Impact (Yes/No)
R-1204	Figure E-8	B-Residential	67	51	68	17	Yes
R-1205	Figure E-8	B-Residential	67	51	63	12	Yes
R-1206	Figure E-8	B-Residential	67	51	62	11	Yes
R-1207	Figure E-8	B-Residential	67	51	68	17	Yes
R-1208	Figure E-8	B-Residential	67	51	64	13	Yes
R-1209	Figure E-8	B-Residential	67	51	68	17	Yes
R-1210	Figure E-8	B-Residential	67	51	64	13	Yes
R-1211	Figure E-8	B-Residential	67	51	63	12	Yes
R-1212	Figure E-8	B-Residential	67	51	68	17	Yes
R-1213	Figure E-8	B-Residential	67	51	64	13	Yes
R-1214	Figure E-8	B-Residential	67	51	68	17	Yes
R-1215	Figure E-8	B-Residential	67	51	63	12	Yes
R-1216	Figure E-8	B-Residential	67	51	64	13	Yes
R-1217	Figure E-8	B-Residential	67	51	68	17	Yes
R-1218	Figure E-8	B-Residential	67	51	63	12	Yes
R-1219	Figure E-8	B-Residential	67	51	64	13	Yes
R-1220	Figure E-8	B-Residential	67	51	67	16	Yes
R-1221	Figure E-8	B-Residential	67	51	64	13	Yes
R-1222	Figure E-8	B-Residential	67	51	64	13	Yes
R-1223	Figure E-8	B-Residential	67	51	67	16	Yes
R-1224	Figure E-8	B-Residential	67	51	64	13	Yes
R-1225	Figure E-7	C-Mountain Bike Trail	67	51	67	16	Yes
R-1226	Figure E-8	B-Residential	67	51	68	17	Yes
R-1227	Figure E-7	C-Picnic areas	67	51	53	2	No
R-1228	Figure E-8	B-Residential	67	51	64	13	Yes
R-1229	Figure E-8	B-Residential	67	51	65	14	Yes
R-1230	Figure E-8	B-Residential	67	51	67	16	Yes
R-1231	Figure E-8	B-Residential	67	51	62	11	Yes
R-1232	Figure E-8	B-Residential	67	51	61	10	No
R-1234	Figure E-8	B-Residential	67	51	61	10	No
R-1235	Figure E-8	B-Residential	67	51	60	9	No
R-1236	Figure E-7	C-Mountain Bike Trail	67	50	65	15	Yes
R-1238	Figure E-10	B-Residential	67	51	58	7	No
R-1239	Figure E-10	B-Residential	67	51	66	15	Yes
R-1240	Figure E-10	B-Residential	67	51	58	7	No
R-1241	Figure E-10	B-Residential	67	51	68	17	Yes
R-1242	Figure E-10	B-Residential	67	51	58	7	No
R-1243	Figure E-10	B-Residential	67	51	62	11	Yes

Traffic Noise Analysis Report

Table 13. Segment E Traffic Noise Levels dB(A) Leq

Segment E Representative Receiver	Figure	NAC Category	NAC Level	Existing	Predicted 2050	Change (+/-)	Noise Impact (Yes/No)
R-1244	Figure E-10	B-Residential	67	51	61	10	No
R-1245	Figure E-10	B-Residential	67	51	64	13	Yes
R-1246	Figure E-10	B-Residential	67	51	61	10	No
R-1247	Figure E-10	B-Residential	67	51	60	9	No
R-1248	Figure E-10	B-Residential	67	51	59	8	No
R-1249	Figure E-10	B-Residential	67	51	68	17	Yes
R-1250	Figure E-10	B-Residential	67	51	58	7	No
R-1251	Figure E-10	B-Residential	67	51	67	16	Yes
R-1252	Figure E-10	B-Residential	67	51	57	6	No
R-1253	Figure E-10	B-Residential	67	51	67	16	Yes
R-1254	Figure E-10	B-Residential	67	51	62	11	Yes
R-1255	Figure E-10	B-Residential	67	51	61	10	No
R-1256	Figure E-10	B-Residential	67	51	64	13	Yes
R-1257	Figure E-10	B-Residential	67	51	60	9	No
R-1258	Figure E-10	B-Residential	67	51	59	8	No
R-1259	Figure E-10	B-Residential	67	51	58	7	No
R-1260	Figure E-10	B-Residential	67	51	57	6	No
R-1261	Figure E-10	B-Residential	67	51	67	16	Yes
R-1262	Figure E-10	B-Residential	67	51	67	16	Yes
R-1263	Figure E-10	B-Residential	67	51	67	16	Yes
R-1264	Figure E-10	B-Residential	67	51	61	10	No
R-1265	Figure E-10	B-Residential	67	51	63	12	Yes
R-1266	Figure E-10	B-Residential	67	51	60	9	No
R-1267	Figure E-10	B-Residential	67	51	59	8	No
R-1268	Figure E-10	B-Residential	67	51	59	8	No
R-1269	Figure E-10	B-Residential	67	51	58	7	No
R-1270	Figure E-10	B-Residential	67	51	57	6	No
R-1271	Figure E-10	B-Residential	67	51	67	16	Yes
R-1272	Figure E-10	B-Residential	67	51	67	16	Yes
R-1273	Figure E-10	B-Residential	67	51	67	16	Yes
R-1274	Figure E-10	B-Residential	67	51	60	9	No
R-1275	Figure E-10	B-Residential	67	51	60	9	No
R-1276	Figure E-10	B-Residential	67	51	59	8	No
R-1277	Figure E-10	B-Residential	67	51	58	7	No
R-1278	Figure E-10	B-Residential	67	51	62	11	Yes
R-1279	Figure E-10	B-Residential	67	51	58	7	No
R-1280	Figure E-10	B-Residential	67	51	57	6	No
R-1281	Figure E-10	B-Residential	67	51	56	5	No
R-1282	Figure E-10	B-Residential	67	51	67	16	Yes

Traffic Noise Analysis Report

Table 13. Segment E Traffic Noise Levels dB(A) Leq

Segment E Representative Receiver	Figure	NAC Category	NAC Level	Existing	Predicted 2050	Change (+/-)	Noise Impact (Yes/No)
R-1283	Figure E-10	B-Residential	67	51	66	15	Yes
R-1284	Figure E-10	B-Residential	67	51	66	15	Yes
R-1285	Figure E-10	B-Residential	67	51	60	9	No
R-1286	Figure E-10	B-Residential	67	51	59	8	No
R-1287	Figure E-10	B-Residential	67	51	58	7	No
R-1288	Figure E-10	B-Residential	67	51	57	6	No
R-1289	Figure E-10	B-Residential	67	51	57	6	No
R-1290	Figure E-10	B-Residential	67	51	57	6	No
R-1291	Figure E-10	B-Residential	67	51	56	5	No
R-1292	Figure E-10	B-Residential	67	51	62	11	Yes
R-1293	Figure E-10	B-Residential	67	51	56	5	No
R-1294	Figure E-10	B-Residential	67	51	55	4	No
R-1295	Figure E-10	B-Residential	67	51	65	14	Yes
R-1296	Figure E-10	B-Residential	67	51	64	13	Yes
R-1297	Figure E-10	B-Residential	67	51	58	7	No
R-1298	Figure E-10	B-Residential	67	51	57	6	No
R-1299	Figure E-10	B-Residential	67	51	61	10	No
R-1300	Figure E-10	B-Residential	67	51	63	12	Yes
R-1301	Figure E-10	B-Residential	67	51	59	8	No
R-1302	Figure E-10	B-Residential	67	51	59	8	No
R-1303	Figure E-10	B-Residential	67	51	63	12	Yes
R-1304	Figure E-10	B-Residential	67	51	57	6	No
R-1305	Figure E-10	B-Residential	67	51	61	10	No
R-1306	Figure E-10	B-Residential	67	51	59	8	No
R-1307	Figure E-10	B-Residential	67	51	58	7	No
R-1308	Figure E-10	B-Residential	67	51	60	9	No
R-1309	Figure E-10	B-Residential	67	51	58	7	No
R-1310	Figure E-10	B-Residential	67	51	57	6	No
R-1311	Figure E-10	B-Residential	67	51	59	8	No
R-1312	Figure E-10	B-Residential	67	51	58	7	No
R-1313	Figure E-10	B-Residential	67	51	58	7	No
R-1314	Figure E-10	B-Residential	67	51	57	6	No
R-1315	Figure E-10	B-Residential	67	51	60	9	No
R-1317	Figure E-10	B-Residential	67	51	59	8	No
R-1318	Figure E-10	B-Residential	67	51	58	7	No
R-1319	Figure E-10	B-Residential	67	51	57	6	No
R-1320	Figure E-10	B-Residential	67	51	57	6	No
R-1321	Figure E-10	B-Residential	67	51	58	7	No
R-1322	Figure E-10	B-Residential	67	51	56	5	No

Traffic Noise Analysis Report

Table 13. Segment E Traffic Noise Levels dB(A) Leq

Segment E Representative Receiver	Figure	NAC Category	NAC Level	Existing	Predicted 2050	Change (+/-)	Noise Impact (Yes/No)
R-1323	Figure E-10	B-Residential	67	51	56	5	No
R-1324	Figure E-10	B-Residential	67	51	58	7	No
R-1325	Figure E-10	B-Residential	67	51	58	7	No
R-1326	Figure E-10	B-Residential	67	51	57	6	No
R-1327	Figure E-10	B-Residential	67	51	57	6	No
R-1328	Figure E-10	B-Residential	67	51	56	5	No
R-1329	Figure E-10	B-Residential	67	51	55	4	No
R-1330	Figure E-10	B-Residential	67	51	56	5	No
R-1331	Figure E-10	B-Residential	67	51	56	5	No
R-1332	Figure E-10	B-Residential	67	51	57	6	No
R-1333	Figure E-10	B-Residential	67	51	57	6	No
R-1334	Figure E-10	B-Residential	67	51	56	5	No
R-1335	Figure E-10	B-Residential	67	51	54	3	No
R-1336	Figure E-10	B-Residential	67	51	54	3	No
R-1337	Figure E-10	B-Residential	67	51	55	4	No
R-1338	Figure E-10	B-Residential	67	51	55	4	No
R-1339	Figure E-10	B-Residential	67	51	56	5	No
R-1340	Figure E-10	B-Residential	67	51	56	5	No
R-1341	Figure E-10	B-Residential	67	51	57	6	No
R-1342	Figure E-10	B-Residential	67	51	54	3	No
R-1343	Figure E-10	B-Residential	67	51	54	3	No
R-1344	Figure E-10	B-Residential	67	51	54	3	No
R-1345	Figure E-10	B-Residential	67	51	56	5	No
R-1346	Figure E-10	B-Residential	67	51	60	9	No
R-1347	Figure E-10	B-Residential	67	51	56	5	No
R-1348	Figure E-10	B-Residential	67	51	54	3	No
R-1349	Figure E-10	B-Residential	67	51	60	9	No
R-1350	Figure E-10	B-Residential	67	51	56	5	No
R-1351	Figure E-10	B-Residential	67	51	55	4	No
R-1352	Figure E-10	B-Residential	67	51	62	11	Yes
R-1353	Figure E-10	B-Residential	67	51	55	4	No
R-1354	Figure E-10	B-Residential	67	51	61	10	No
R-1355	Figure E-10	B-Residential	67	51	54	3	No
R-1356	Figure E-10	B-Residential	67	51	61	10	No
R-1357	Figure E-10	B-Residential	67	51	54	3	No
R-1358	Figure E-10	B-Residential	67	51	61	10	No
R-1359	Figure E-10	B-Residential	67	51	54	3	No
R-1360	Figure E-10	B-Residential	67	51	60	9	No
R-1361	Figure E-10	B-Residential	67	51	54	3	No

Table 13. Segment E Traffic Noise Levels dB(A) Leq

Segment E Representative Receiver	Figure	NAC Category	NAC Level	Existing	Predicted 2050	Change (+/-)	Noise Impact (Yes/No)
R-1362	Figure E-10	B-Residential	67	51	59	8	No
R-1363	Figure E-10	B-Residential	67	51	53	2	No
R-1364	Figure E-10	B-Residential	67	51	59	8	No
R-1365	Figure E-10	B-Residential	67	51	53	2	No
R-1366	Figure E-10	B-Residential	67	51	58	7	No
R-1367	Figure E-10	B-Residential	67	51	57	6	No
R-1368	Figure E-10	B-Residential	67	51	57	6	No
R-1370	Figure E-10	B-Residential	67	51	50	-1	No
R-1371	Figure E-10	B-Residential	67	51	51	0	No
R-1372	Figure E-10	B-Residential	67	51	52	1	No
R-1373	Figure E-10	B-Residential	67	51	56	5	No
R-1374	Figure E-13	B-Residential	67	51	66	15	Yes

Abbreviations: NAC, Noise Abatement Criteria; dB(A), A-weighted decibel; Leq, average/equivalent sound level. Existing noise levels in **BOLD** were determined based on nearby ambient measurements. These receptors are not near any existing roadways that produce enough traffic noise to calculate existing noise levels. Data sheets are included in Attachments C and D.

As indicated in Table 13, the proposed project would result in a traffic noise impact at one or more representative receiver locations.

Noise abatement measures were considered for each location with predicted noise impacts.

Abatement Analysis

Noise barriers would not be feasible and reasonable for any of the following impacted receptors, and therefore, are not proposed for incorporation into the project:

R-1170, R-1175, R-1187, R-1188, R-1190 and R-1374- These receptors are separate, isolated residences, which are not associated with a neighborhood or subdivision. Because a noise abatement measure must potentially benefit a minimum of two impacted receptors, noise abatement for these locations is not feasible.

Barrier E03: R-1191 (Figure E-4 and Figure E-5)- This receiver represents total of 752 equivalent dwelling units of City Parkland along all alternatives. Based on preliminary calculations, a noise barrier 2,262 feet in length, 20 feet in height, and located along the ROW would not be sufficient to achieve the minimum, feasible reduction of 5 dB(A) for a majority of impacted receptors or the noise reduction design goal of 7 dB(A).

Barrier E06: R-1174 and R-1182 to R-1184 (Figure E-3 and Figure E-4) – An existing barrier is located in front of the Heatherwood neighborhood, where noise impacts at the sides of the barrier occur at locations where the existing barrier cannot adequately address the increase in traffic noise under the build condition. While the existing neighborhood wall does provide some noise reduction, the existing wall does not wrap around the ends or sides of the barrier and therefore does not provide acoustical shielding to homes deeper into the neighborhood due to flanking.

These receivers represent a total of 4 equivalent dwelling units in the Heatherwood neighborhood along all alternatives. Based on preliminary calculations, a noise barrier 1,875 feet in length, 20 feet in height, and located along the ROW would not be sufficient to achieve the minimum, feasible reduction of 5 dB(A) for a majority of impacted receptors or the noise reduction design goal of 7 dB(A).

Feasible and Reasonable Barriers

Noise barriers would be feasible and reasonable for the following impacted receptors, and therefore, are proposed for incorporation into the project. Table 14 summarizes the proposed noise barriers.

Table 14. Segment E Proposed Noise Barriers

Barrier	Locations	Receptor Number - Type	Number of Benefited Receivers	Length (feet)	Height (feet)	Total Barrier Area (ft ²)	Length / Benefited Receiver (ft)
E04	Erwin Park	R-1225 and R-1236 (Park)	2	2,399	17	40,783	144
E05	Erwin Farms*	R-1194, R-1196 to R-1200, R-1202 to R-1224, R-1226, R-1228 to R-1230, R-1239, R-1241, R-1243, R1245, R-1249, R-1251, R-1253, R-1254, R-1256, R-1261 to R-1263, R-1265, R-1271 to R-1273, R-1278, R-1282 to R-1284, R-1292, R-1295, R-1296, R-1300, R-1303, and R-1352 (Residential)	43	5,337	11	58,707	1,365

*Note: This development is either under construction or permitted for development. At the time the noise model was conducted, none of the receptors in the development were present.

Barrier E04: R-1225 and R-1236 (Figure E-7, Figure E-8 and Figure E-10) - These receivers represent a total of 284 equivalent dwelling units at Erwin Park along all alternatives. Based on preliminary calculations, a noise barrier 2,399 feet in length, 17 feet in height, and located along the ROW would reduce noise levels by at least 5 dB(A) for 284 benefited dwelling units and meet the noise reduction design goal of 7 dB(A) for at least one of those receptors. With a total area of abatement of 40,783 square feet or 144 square feet per benefited receptor, the barrier would be cost reasonable. Therefore, Barrier E04 is considered acoustically feasible and cost effective.

Barrier E05: R-1194, R-1196 to R-1200, R-1202 to R-1224, R-1226, R-1228 to R-1231, R-1239, R-1241, R-1243, R1245, R-1249, R-1251, R-1253, R-1254, R-1256, R-1261 to R-1263, R-1265, R-1271 to R-1273, R-1278, R-1282 to R-1284, R-1292, R-1295, R-1296, R-1300, R-1303, and R-1352 (Figure E-7, Figure E-8 and Figure E-10) - These receivers represent a total of 60 impacted residences at the Erwin Farms neighborhood along all alternatives. Based on preliminary calculations, a noise barrier 5,337 feet in length, 11 feet in height, and located along the ROW would reduce noise levels by at least 5 dB(A) for 43 benefited receptors and meet the noise reduction design goal of 7 dB(A) for at least one of those

receptors. With a total area of abatement of 58,707 square feet or 1,365 square feet per benefited receptor, the barrier would be cost reasonable. Therefore, Barrier E05 is considered acoustically feasible and cost effective.

Table 15 summarizes the number of receptors that exceed the NAC, proposed barriers, and benefited receivers for each alternative.

Table 15. Summary of Build Alternatives

Statistics	Type of Receptor	Purple Alternative	Blue Alternative	Brown Alternative	Gold Alternative
Number of Receptors that approach/exceed the NAC	Cat B	192	194	342	340
	Cat C	14	13	54	55
	Cat E	0	0	0	0
	Total:	206	207	396	395
Substantial increase	Cat B	83	81	281	283
	Cat C	10	10	47	47
	Cat E	0	0	0	0
	Total:	93	91	328	330
Barriers Proposed	Total:	4 (Barrier A01, A07-2, E04 and E05)	4 (Barrier A01, A07-2, E04 and E05)	6 (Barrier B01, B02, B03, B05-1 E04 and E05)	6 (Barrier B01, B02, B03, B05-1, E04 and E05)
	Cat B	72	72	119	119
Benefited Receivers	Cat C	2	2	4	4
	Cat E	0	0	0	0
	Total:	74	74	123	123

Statement of Likelihood

Any subsequent project design changes may require a reevaluation of this preliminary noise barrier proposal. The final decision to construct the proposed noise barrier will not be made until completion of the project design, utility evaluation, and polling of all benefited and adjacent property owners and residents.

Noise Contours for Land Use Planning

To avoid noise impacts that may result from future development of properties adjacent to the project, local officials responsible for land use control programs must ensure, to the maximum extent possible, that no new activities are planned or constructed along or within the following predicted (2050) noise impact contours.

Table 16. Noise Contours for Land Use Planning

Segment	Land Use	Impact Contour	Distance from Right of Way
A	NAC categories B & C	66 dB(A)	≈ 418 feet
	NAC category E	71 dB(A)	≈ 135 feet
B	NAC categories B & C	66 dB(A)	≈ 610 feet
	NAC category E	71 dB(A)	≈ 243 feet
C	NAC categories B & C	66 dB(A)	≈ 325 feet
	NAC category E	71 dB(A)	≈ 155 feet
D	NAC categories B & C	66 dB(A)	≈ 320 feet
	NAC category E	71 dB(A)	≈ 148 feet
E	NAC categories B & C	66 dB(A)	≈ 433 feet
	NAC category E	71 dB(A)	≈ 89 feet

Source: Guidelines for Analysis and Abatement of Roadway Traffic Noise (TxDOT 2019)

Construction Noise

Noise associated with the construction of the project is difficult to predict. Heavy machinery, the major source of noise in construction, is constantly moving in unpredictable patterns. However, construction normally occurs during daylight hours when occasional loud noises are more tolerable. None of the receptors is expected to be exposed to construction noise for a long duration; therefore, any extended disruption of normal activities is not expected. Provisions will be included in the plans and specifications that require the contractor to make every reasonable effort to minimize construction noise through abatement measures such as work-hour controls and proper maintenance of muffler systems.

Local Official Notification and Date of Public Knowledge Statement

A copy of this traffic noise analysis will be available to local officials. On the date of the environmental decision for this project (Date of Public Knowledge), FHWA and TxDOT are no longer responsible for providing noise abatement for new development adjacent to the project.

List of Attachments

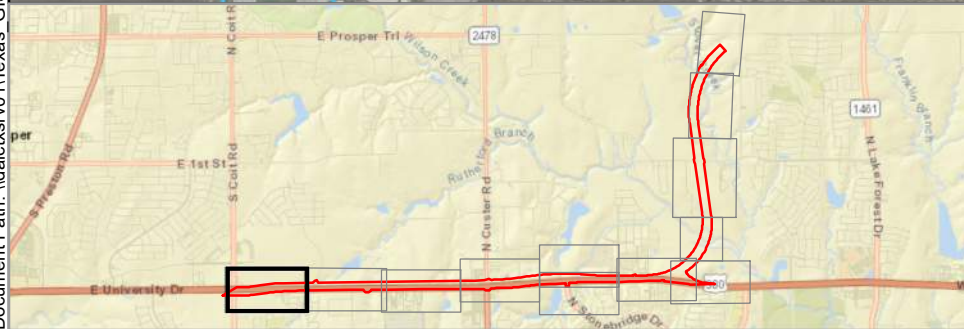
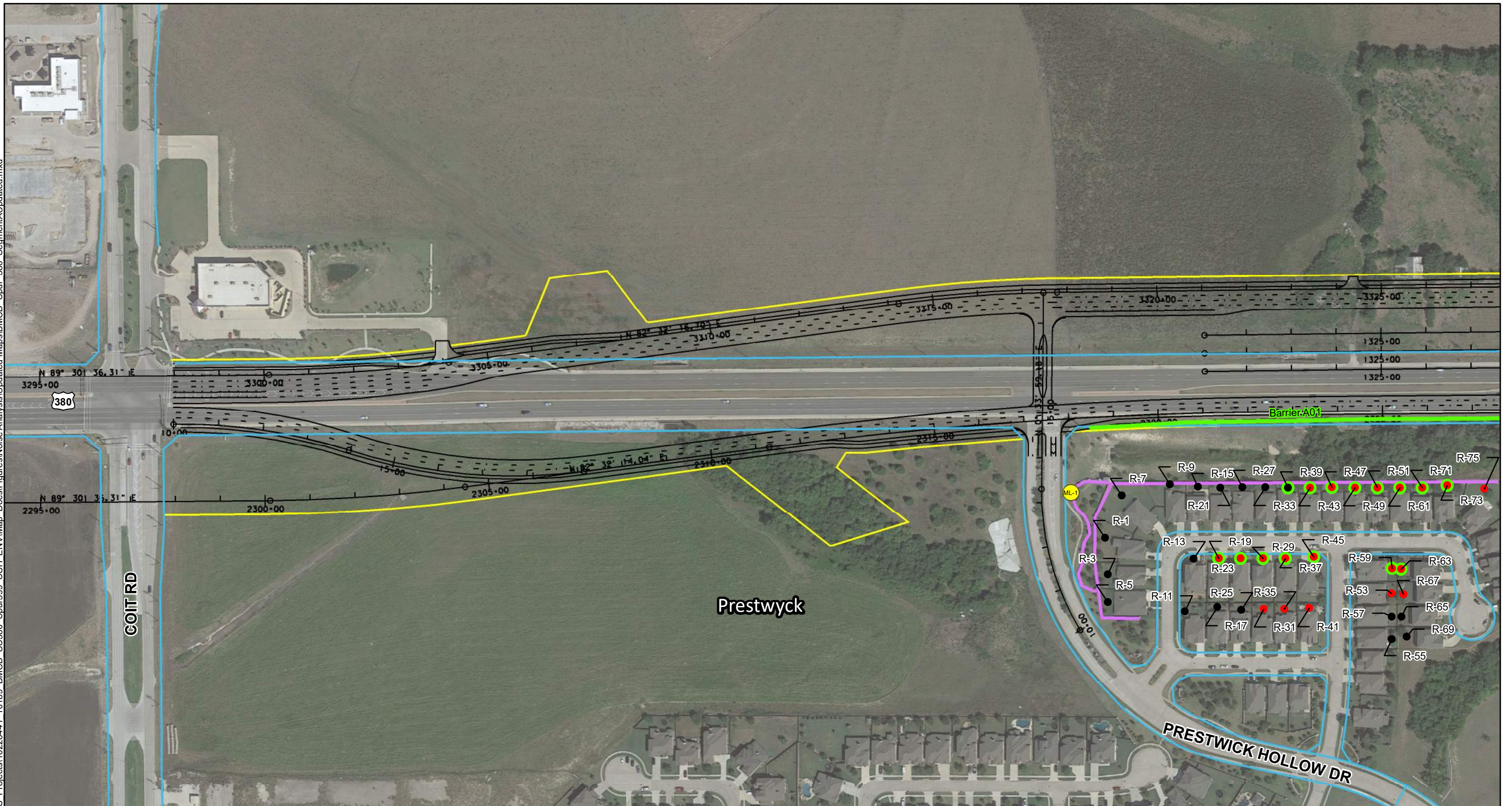
Map figures

Traffic data

Existing Model Validation Study

Ambient Noise Measurement

Attachment A – Map Figures



Legend

- PROPOSED BARRIER
- BARRIER ANALYZED BUT NOT PROPOSED
- IMPACTED RECEIVER
- NON-IMPACTED RECEIVER
- BENEFITED RECEIVER
- RESIDENTIAL DISPLACEMENT
- COMMERCIAL DISPLACEMENT
- EXISTING ROW
- PROPOSED IMPROVEMENTS
- PROPOSED ROW
- EXISTING NEIGHBORHOOD WALLS
- VALIDATION LOCATIONS
- AMBIENT MEASUREMENT SITES

NOISE IMPACTS AND RECEIVERS

US 380
SEGMENT A

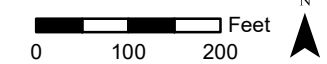
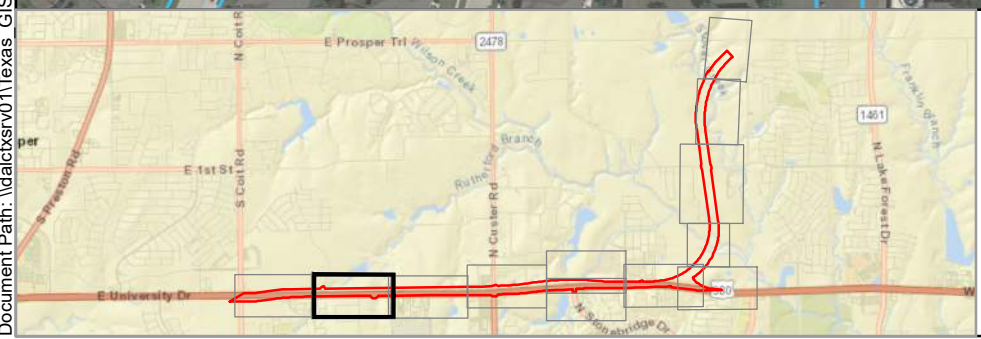
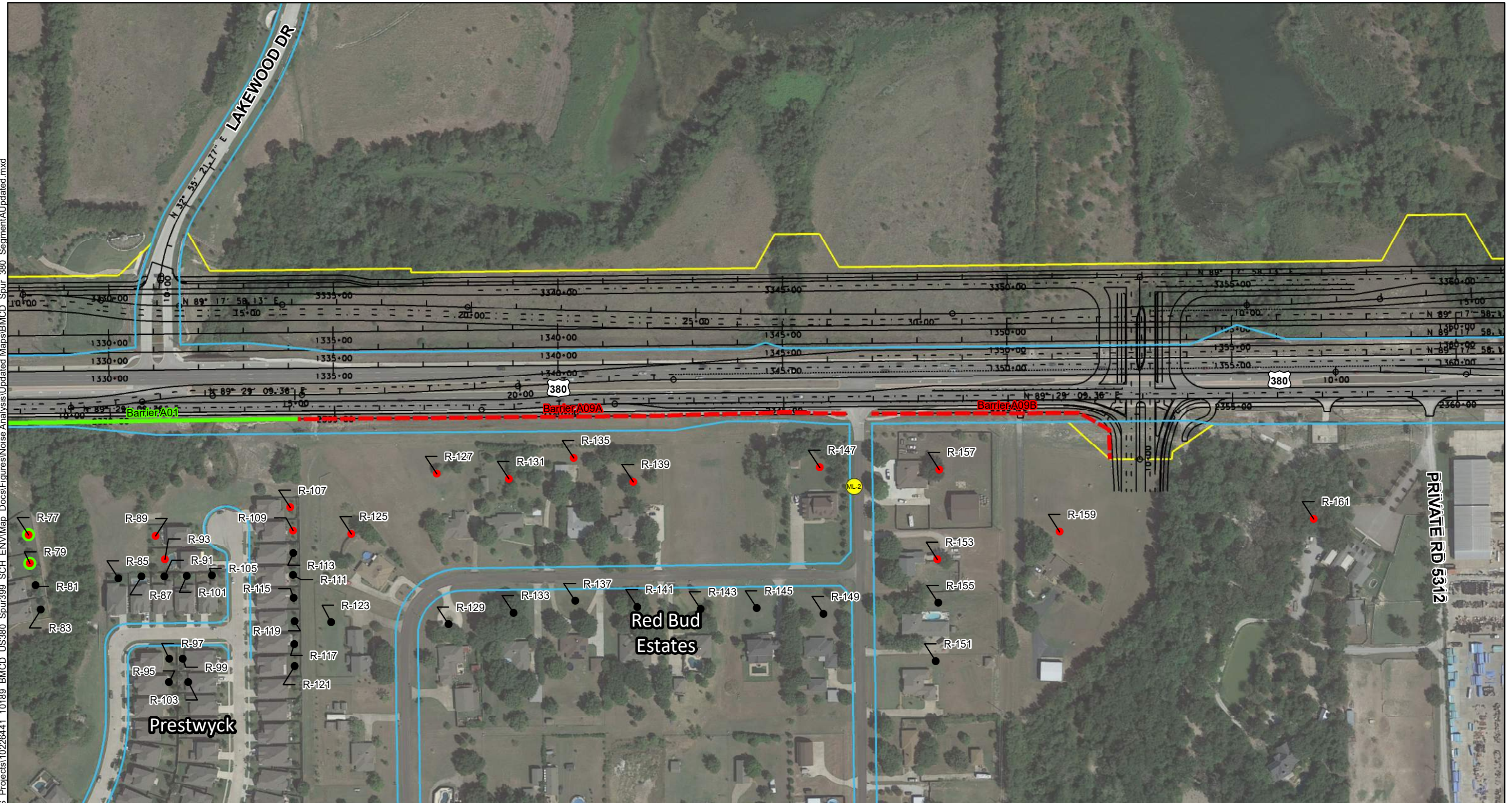


FIGURE A-1
NOV 2022

Document Path: \\dalctsr\01\Texas GIS Projects\10226441_10189_BMCD_US380_Spur399_SCH_ENV\Map_Docs\Figures\Noise Analysis\Updated Maps\BMCD_Spur_380_SegmentAUpdated.mxd



Legend

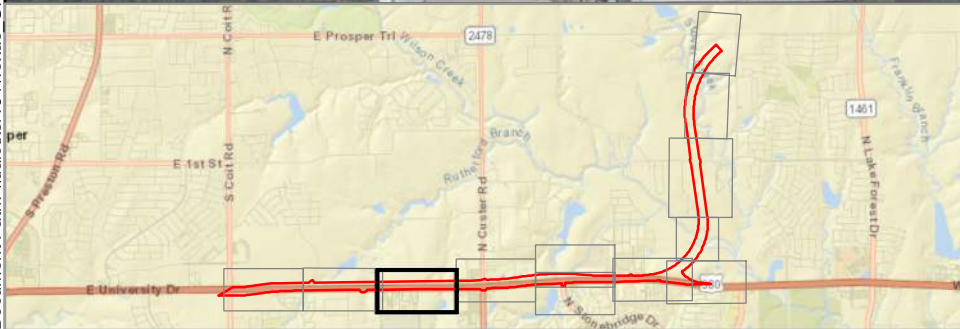
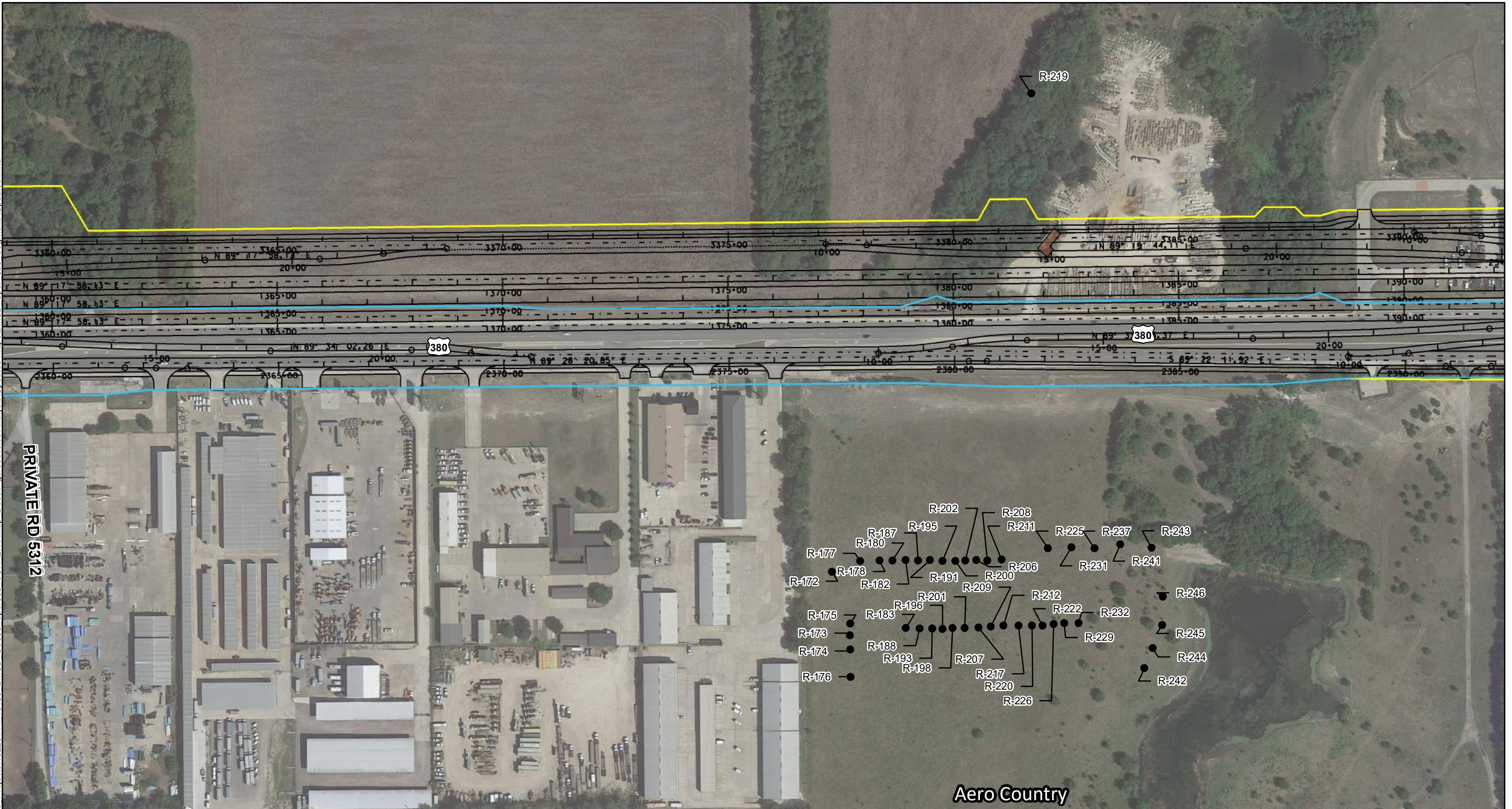
- PROPOSED BARRIER
- - - BARRIER ANALYZED BUT NOT PROPOSED
- IMPACTED RECEIVER
- NON-IMPACTED RECEIVER
- BENEFITED RECEIVER
- RESIDENTIAL DISPLACEMENT
- COMMERCIAL DISPLACEMENT
- EXISTING ROW
- PROPOSED IMPROVEMENTS
- PROPOSED ROW
- EXISTING NEIGHBORHOOD WALLS
- VALIDATION LOCATIONS
- AMBIENT MEASUREMENT SITES

NOISE IMPACTS AND RECEIVERS
US 380
SEGMENT A

0 100 200 Feet

N

FIGURE A-2
NOV 2022



Legend

- PROPOSED BARRIER
- BARRIER ANALYZED BUT NOT PROPOSED
- IMPACTED RECEIVER
- NON-IMPACTED RECEIVER
- BENEFITED RECEIVER
- RESIDENTIAL DISPLACEMENT
- COMMERCIAL DISPLACEMENT
- EXISTING ROW
- PROPOSED IMPROVEMENTS
- PROPOSED ROW
- EXISTING NEIGHBORHOOD WALLS
- VALIDATION LOCATIONS
- AMBIENT MEASUREMENT SITES

NOISE IMPACTS AND RECEIVERS

US 380
SEGMENT A

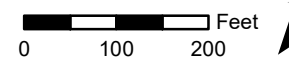
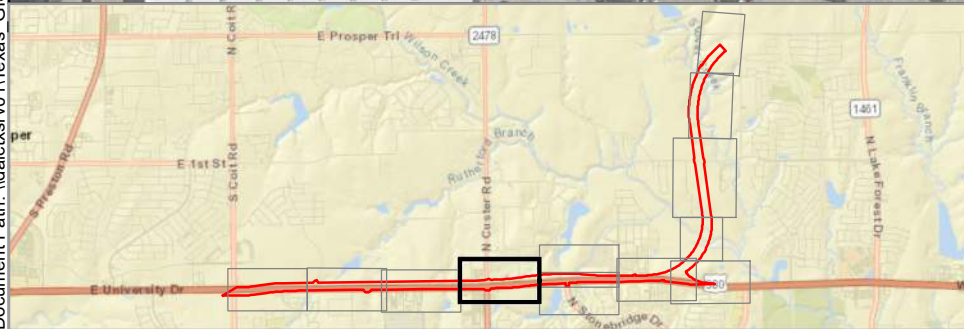
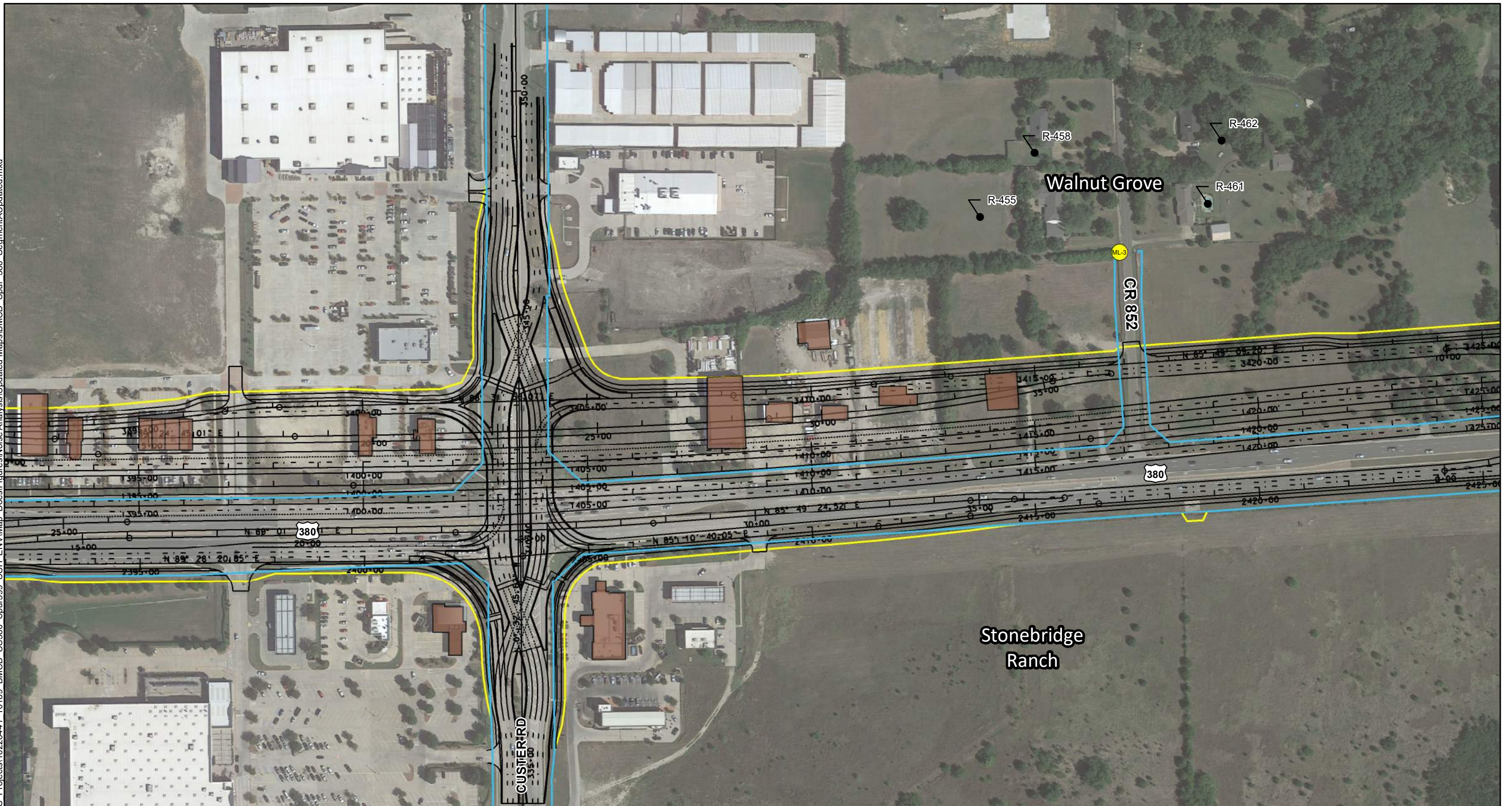


FIGURE A-3
NOV 2022



Legend

- PROPOSED BARRIER
- BARRIER ANALYZED BUT NOT PROPOSED
- IMPACTED RECEIVER
- NON-IMPACTED RECEIVER
- BENEFITED RECEIVER
- RESIDENTIAL DISPLACEMENT
- COMMERCIAL DISPLACEMENT
- EXISTING ROW
- PROPOSED IMPROVEMENTS
- PROPOSED ROW
- EXISTING NEIGHBORHOOD WALLS
- VALIDATION LOCATIONS
- AMBIENT MEASUREMENT SITES

NOISE IMPACTS AND RECEIVERS

US 380
SEGMENT A

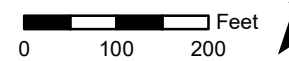
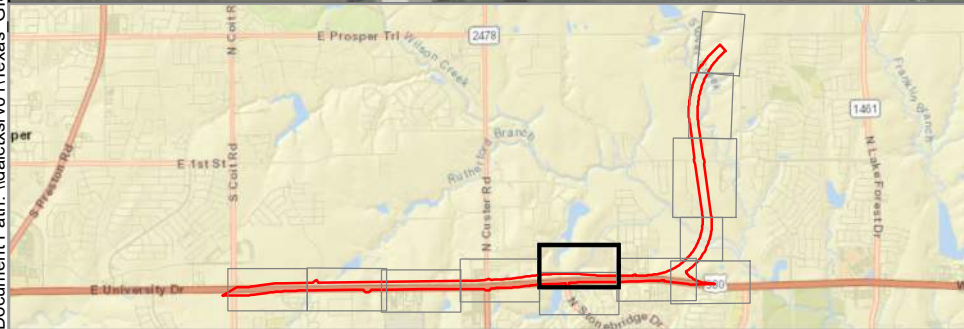
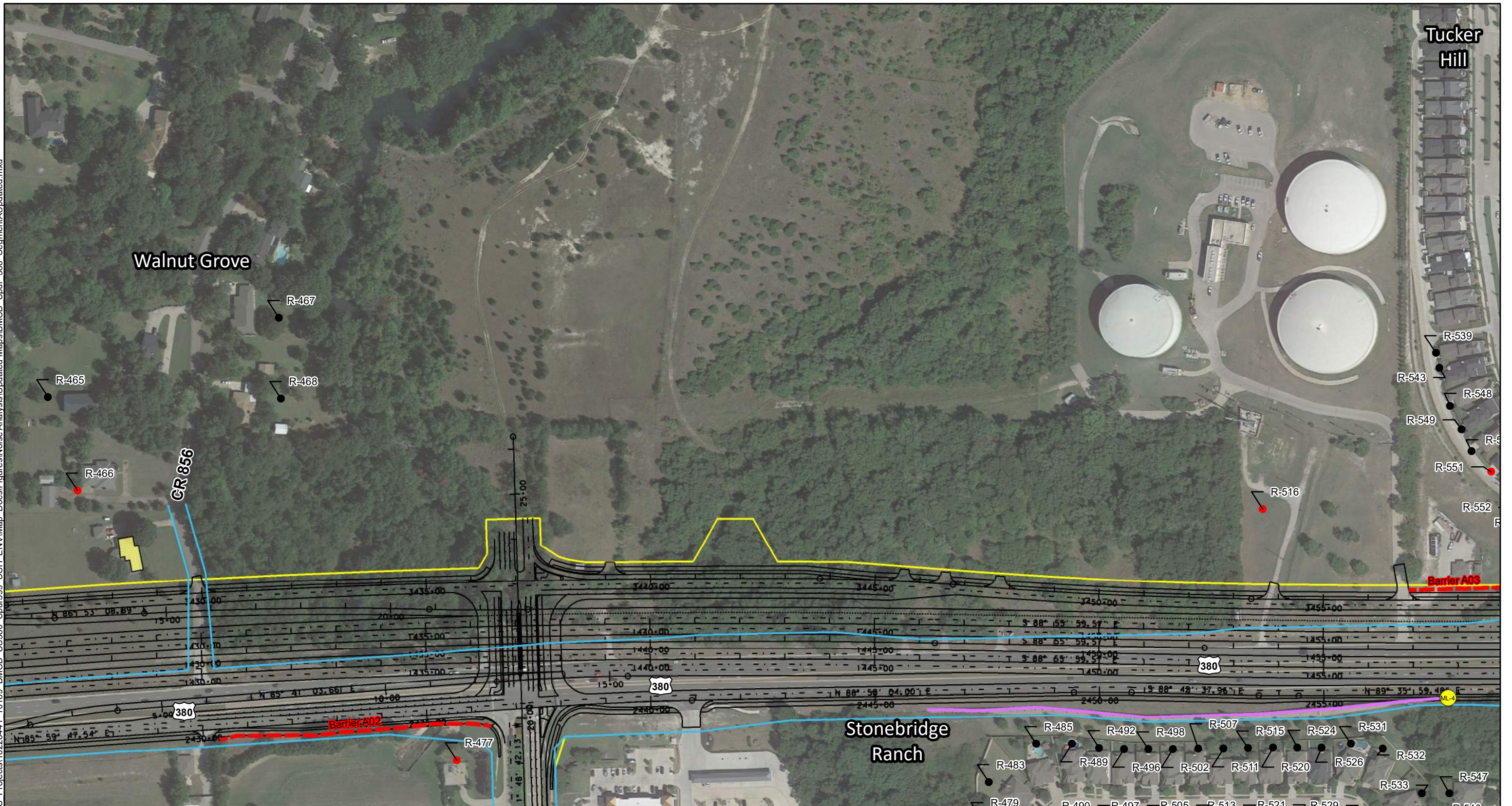


FIGURE A-4
NOV 2022



Legend

- PROPOSED BARRIER
- - - BARRIER ANALYZED BUT NOT PROPOSED
- IMPACTED RECEIVER
- NON-IMPACTED RECEIVER
- BENEFITED RECEIVER
- RESIDENTIAL DISPLACEMENT
- COMMERCIAL DISPLACEMENT
- EXISTING ROW
- PROPOSED IMPROVEMENTS
- PROPOSED ROW
- EXISTING NEIGHBORHOOD WALLS
- VALIDATION LOCATIONS
- AMBIENT MEASUREMENT SITES

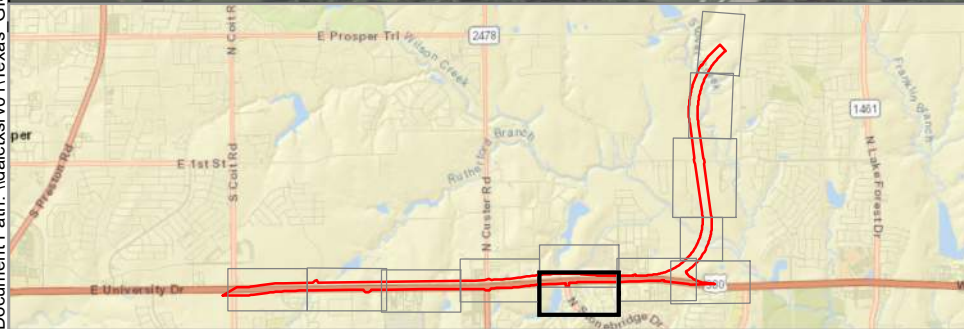
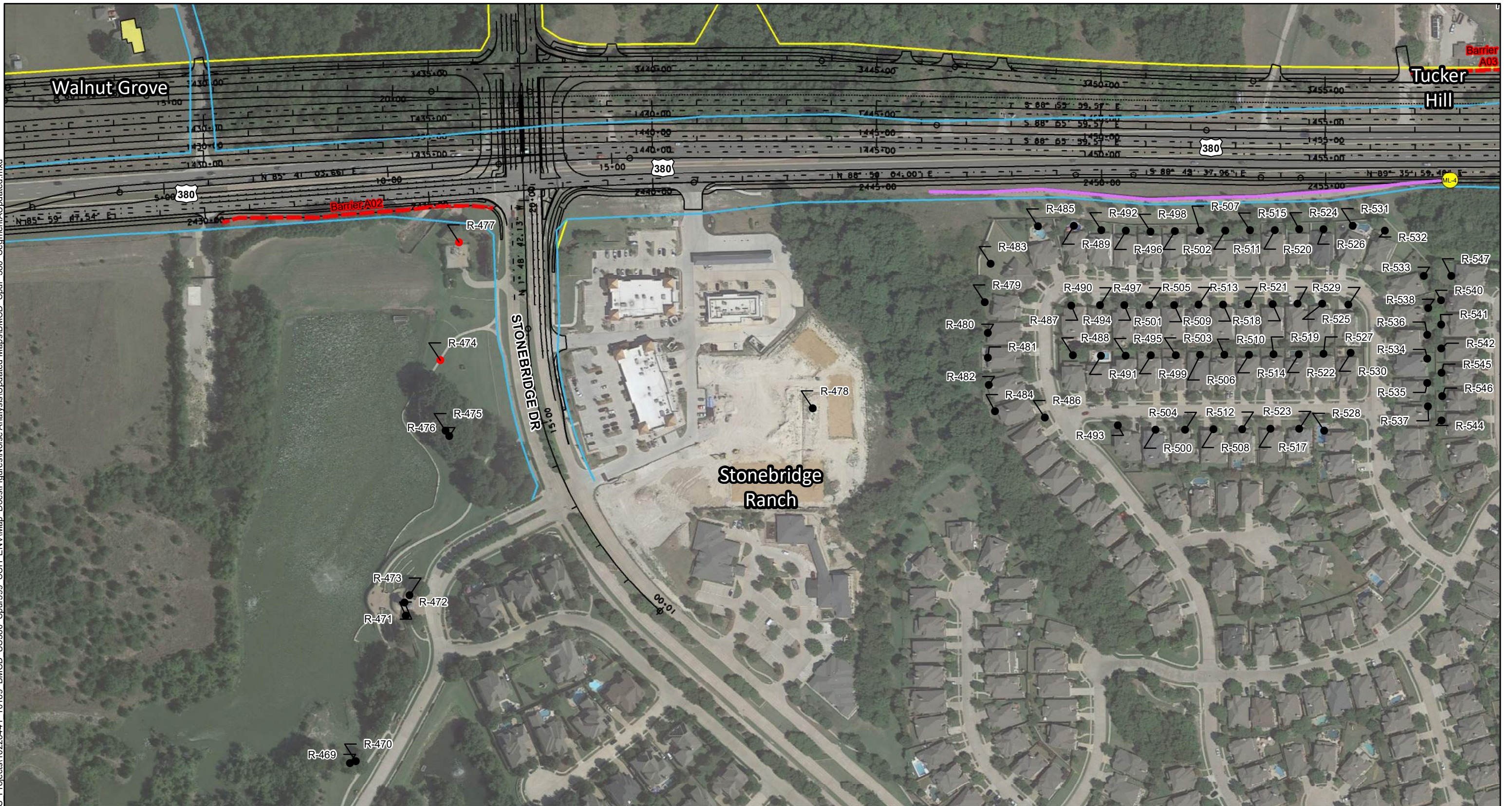
NOISE IMPACTS AND RECEIVERS

US 380
SEGMENT A

0 100 200 Feet

North Arrow

FIGURE A-5
NOV 2022



Legend

- PROPOSED BARRIER
- - - BARRIER ANALYZED BUT NOT PROPOSED
- IMPACTED RECEIVER
- NON-IMPACTED RECEIVER
- BENEFITED RECEIVER
- RESIDENTIAL DISPLACEMENT
- COMMERCIAL DISPLACEMENT
- EXISTING ROW
- PROPOSED IMPROVEMENTS
- PROPOSED ROW
- EXISTING NEIGHBORHOOD WALLS
- VALIDATION LOCATIONS
- AMBIENT MEASUREMENT SITES

NOISE IMPACTS AND RECEIVERS

US 380
SEGMENT A

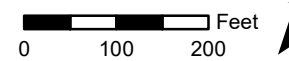
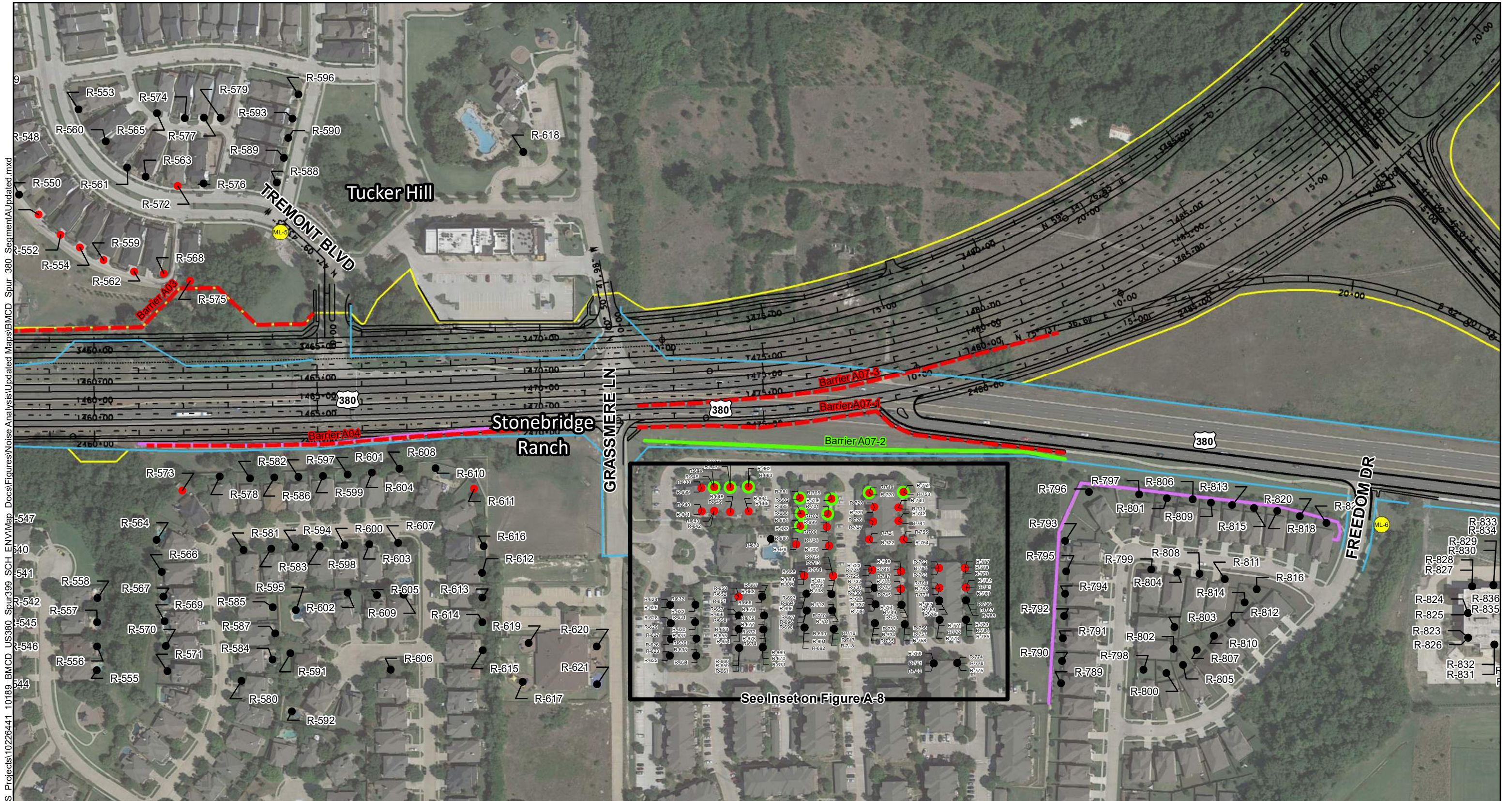
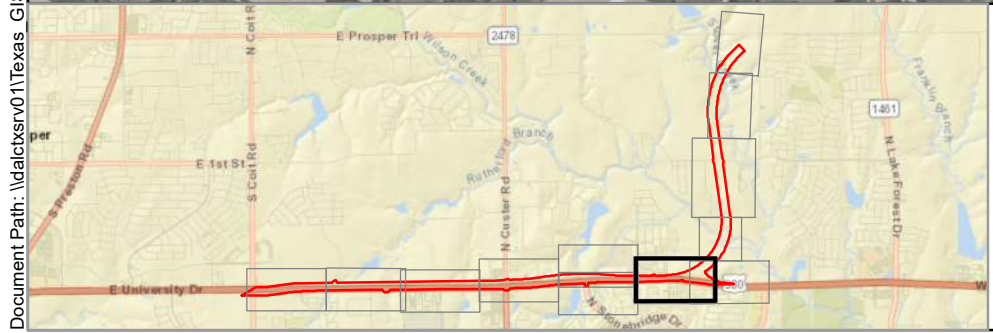


FIGURE A-6
NOV 2022



Document Path: \\dalactxrv01\Texas GIS Projects\102226441_10189_BMCD_US380_Spur399_SCH_ENVM\Map_Docs\Figures\Noise Analysis\Updated Maps\BMCD_Spur_380_SegmentAUpdated.mxd



Legend

— PROPOSED BARRIER	— EXISTING ROW
- - - BARRIER ANALYZED BUT NOT PROPOSED	— PROPOSED IMPROVEMENTS
● IMPACTED RECEIVER	— PROPOSED ROW
● NON-IMPACTED RECEIVER	— EXISTING NEIGHBORHOOD WALLS
● BENEFITED RECEIVER	● VALIDATION LOCATIONS
 RESIDENTIAL DISPLACEMENT	● AMBIENT MEASUREMENT SITES
 COMMERCIAL DISPLACEMENT	

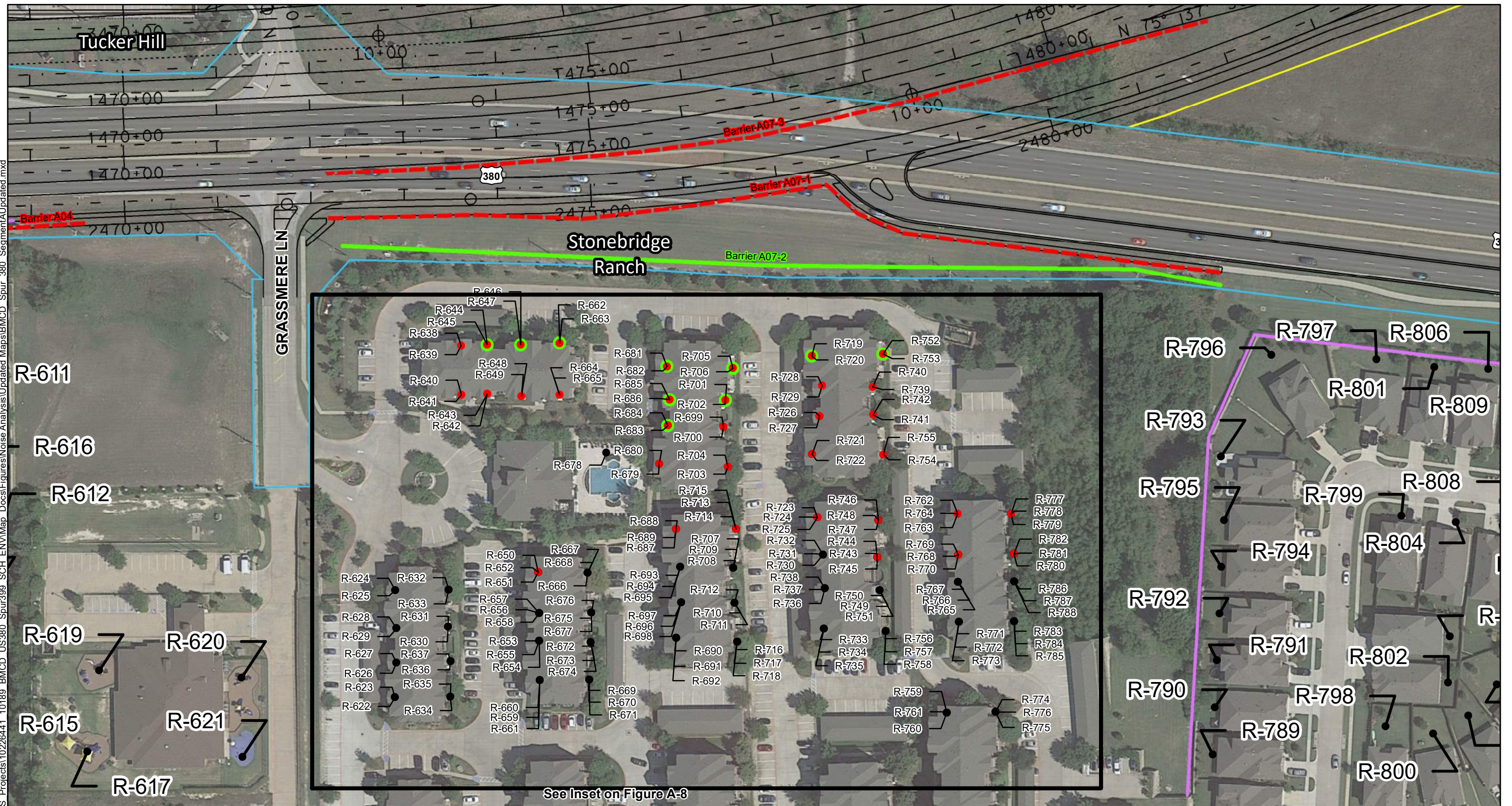
NOISE IMPACTS AND RECEIVERS

US 380
SEGMENT A

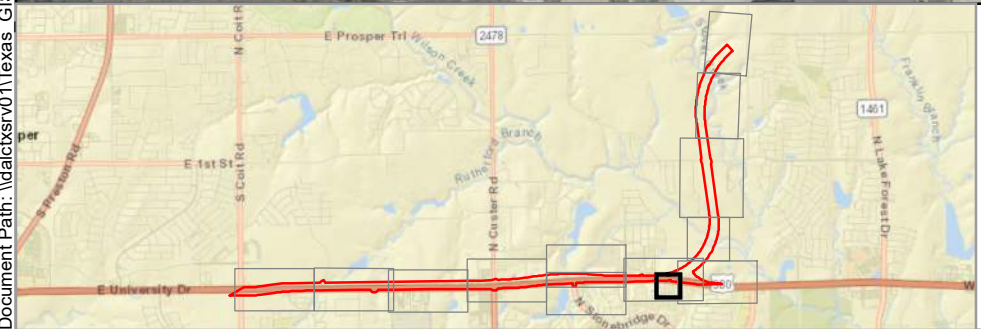
0 100 200 Feet

FIGURE A-7
NOV 2022

Document Path: \\dalctsr\01\Texas GIS Projects\10226441_10189_BMCD_US380_Spur399_SCH_ENV\Map_Docs\Figures\Noise Analysis\Updated Maps\BMCD_Spur_380_SegmentAUpdated.mxd



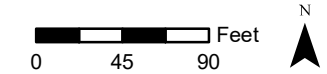
See Inset on Figure A-8

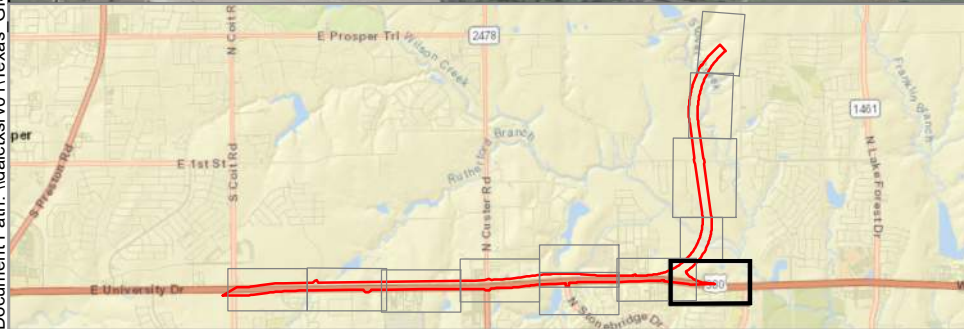
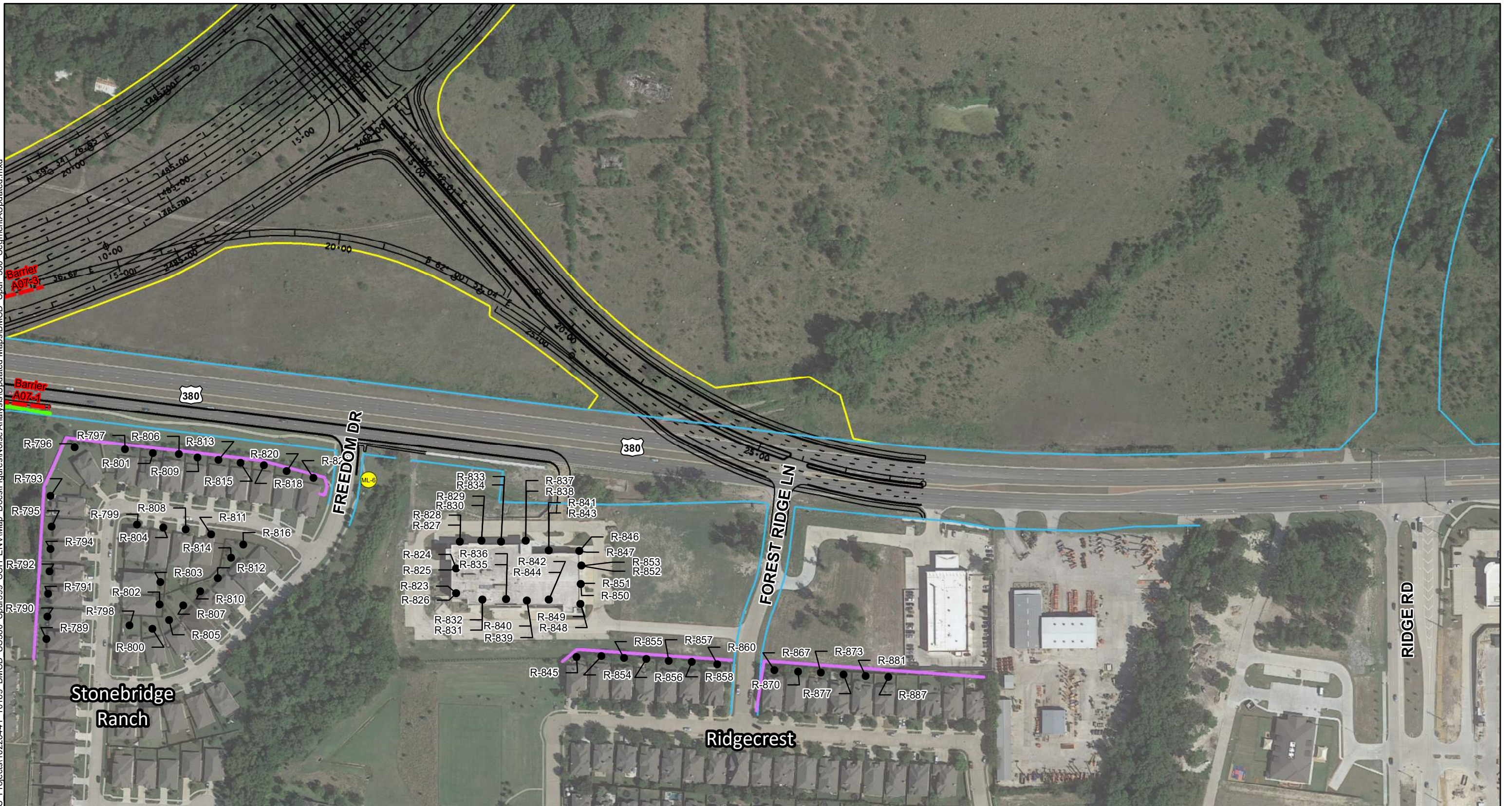


Legend	
	PROPOSED BARRIER
	BARRIER ANALYZED BUT NOT PROPOSED
	IMPACTED RECEIVER
	NON-IMPACTED RECEIVER
	BENEFITED RECEIVER
	RESIDENTIAL DISPLACEMENT
	COMMERCIAL DISPLACEMENT
	EXISTING ROW
	PROPOSED IMPROVEMENTS
	PROPOSED ROW
	EXISTING NEIGHBORHOOD WALLS
	VALIDATION LOCATIONS
	AMBIENT MEASUREMENT SITES

NOISE IMPACTS AND RECEIVERS

US 380
SEGMENT A





Legend

- PROPOSED BARRIER
- BARRIER ANALYZED BUT NOT PROPOSED
- IMPACTED RECEIVER
- NON-IMPACTED RECEIVER
- BENEFITED RECEIVER
- RESIDENTIAL DISPLACEMENT
- COMMERCIAL DISPLACEMENT
- EXISTING ROW
- PROPOSED IMPROVEMENTS
- PROPOSED ROW
- EXISTING NEIGHBORHOOD WALLS
- VALIDATION LOCATIONS
- AMBIENT MEASUREMENT SITES

NOISE IMPACTS AND RECEIVERS

US 380
SEGMENT A

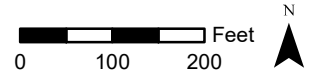
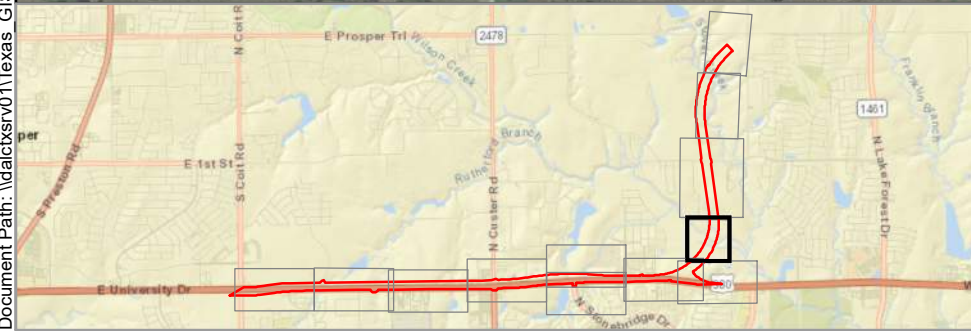
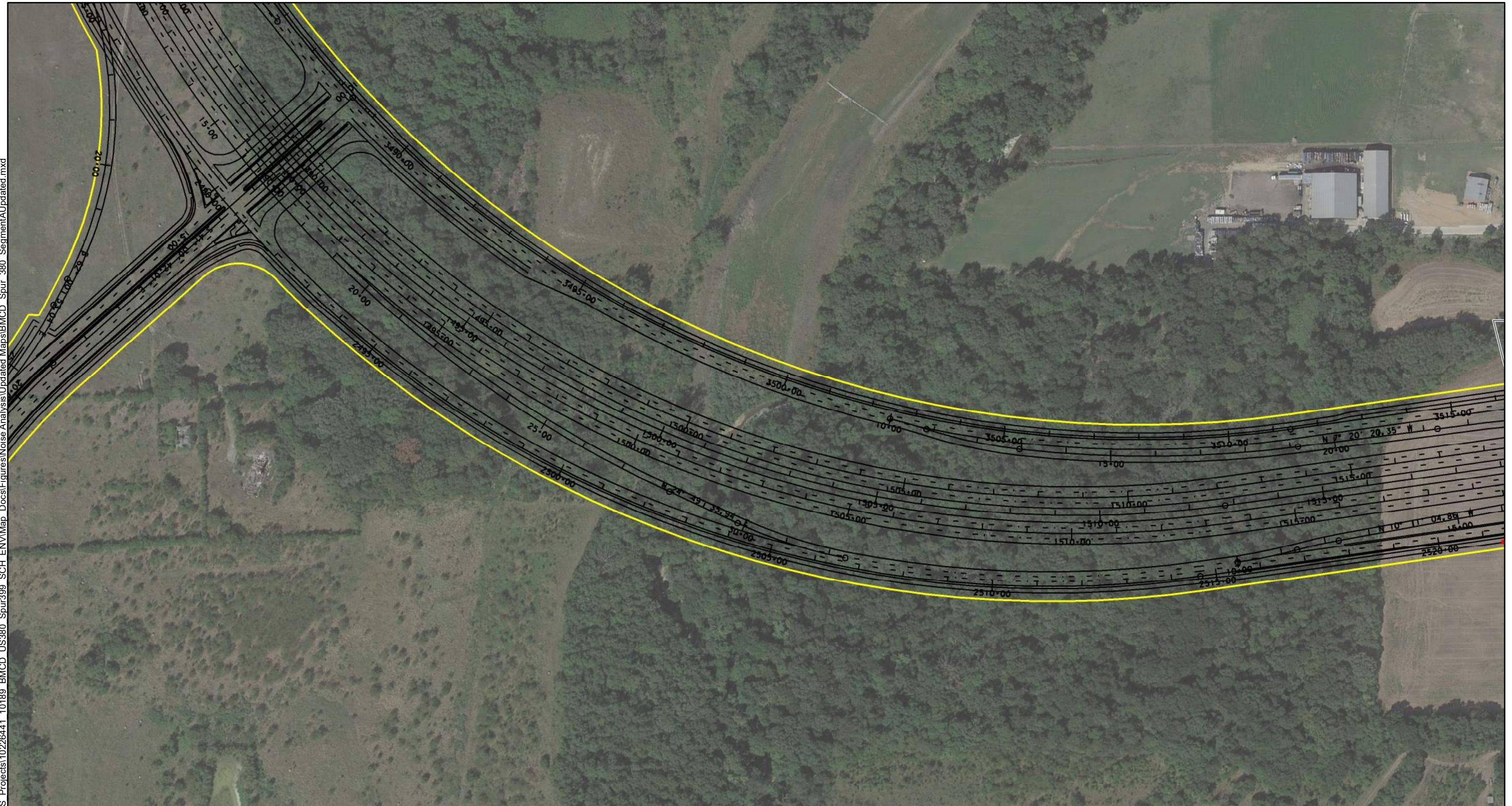


FIGURE A-9
NOV 2022



Legend

PROPOSED BARRIER	EXISTING ROW
BARRIER ANALYZED BUT NOT PROPOSED	PROPOSED IMPROVEMENTS
IMPACTED RECEIVER	PROPOSED ROW
NON-IMPACTED RECEIVER	EXISTING NEIGHBORHOOD WALLS
BENEFITED RECEIVER	VALIDATION LOCATIONS
RESIDENTIAL DISPLACEMENT	AMBIENT MEASUREMENT SITES
COMMERCIAL DISPLACEMENT	

NOISE IMPACTS AND RECEIVERS

US 380
SEGMENT A

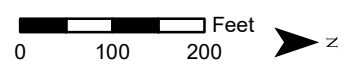
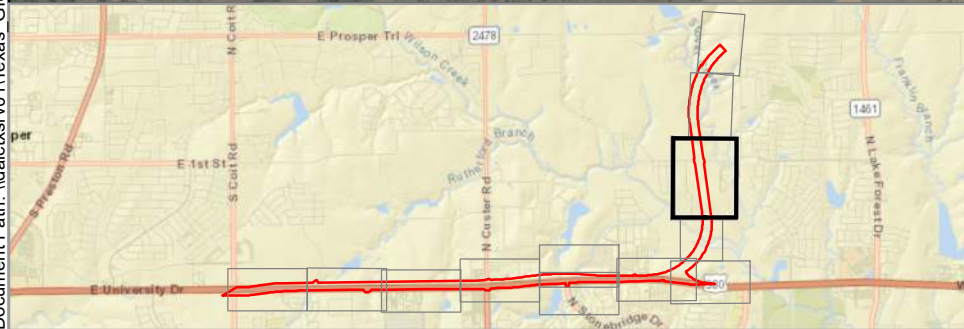
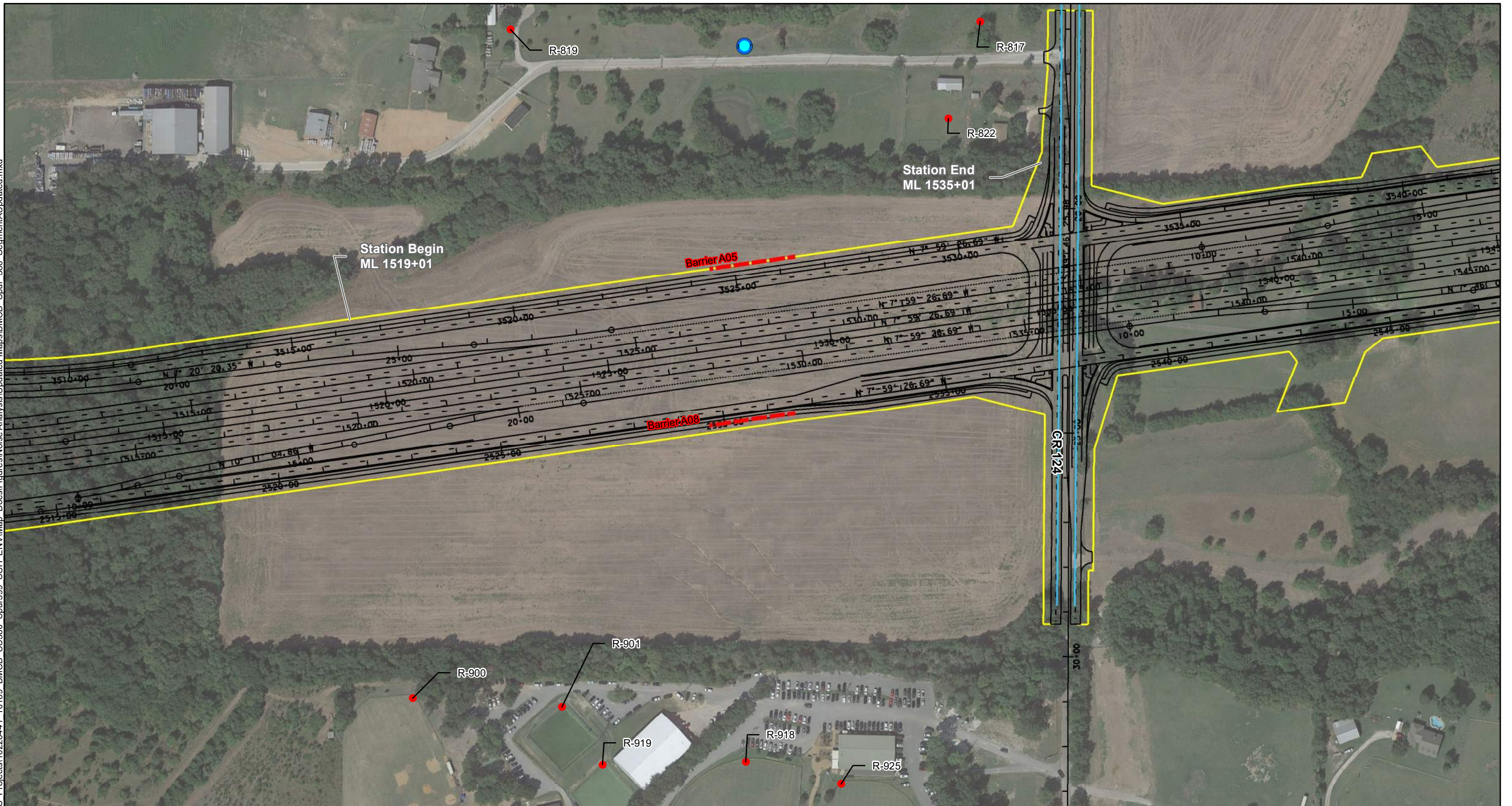


FIGURE A-10
NOV 2022



Legend

- PROPOSED BARRIER
- - - BARRIER ANALYZED BUT NOT PROPOSED
- IMPACTED RECEIVER
- NON-IMPACTED RECEIVER
- BENEFITED RECEIVER
- RESIDENTIAL DISPLACEMENT
- COMMERCIAL DISPLACEMENT
- EXISTING ROW
- PROPOSED IMPROVEMENTS
- PROPOSED ROW
- EXISTING NEIGHBORHOOD WALLS
- VALIDATION LOCATIONS
- AMBIENT MEASUREMENT SITES

NOISE IMPACTS AND RECEIVERS

US 380
SEGMENT A

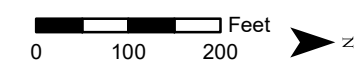
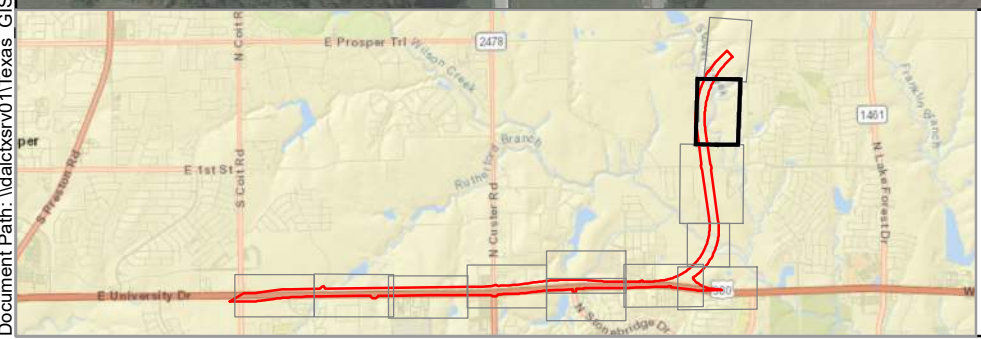
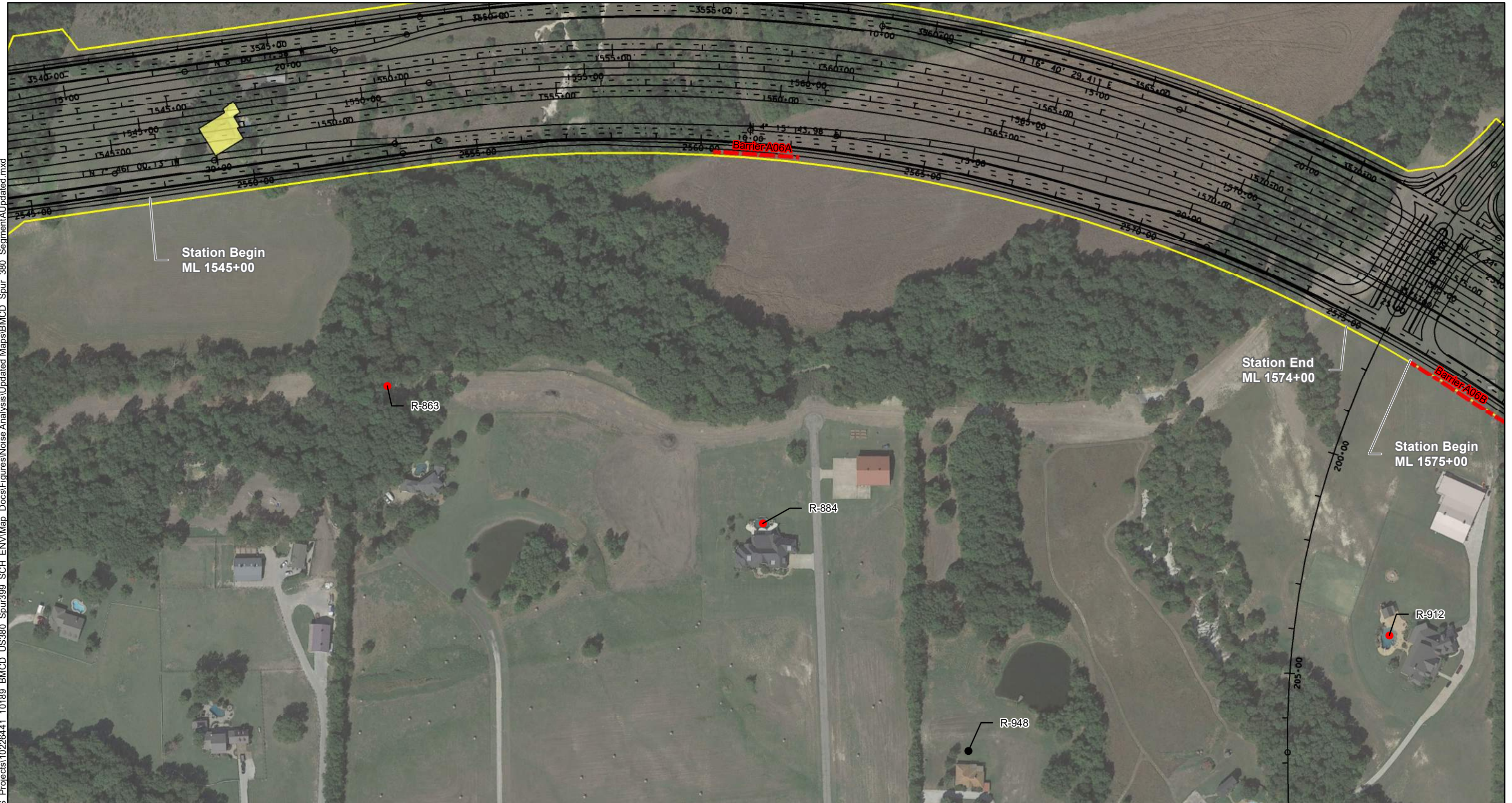


FIGURE A-11
NOV 2022

Document Path: \\dalactxrv01\Texas GIS Projects\10226441_10189_BMCD_US380_Spur399_SCH_ENV\Map Docs\Figures\Noise Analysis\Updated Maps\BMCD_Spur_380_SegmentA\Updated.mxd



Legend

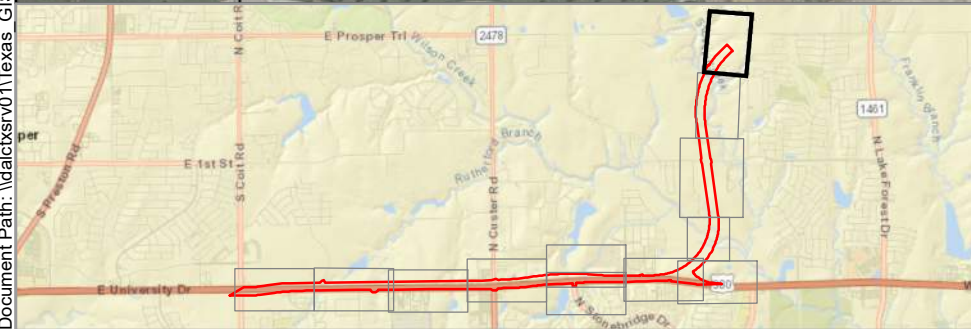
- PROPOSED BARRIER
- - - BARRIER ANALYZED BUT NOT PROPOSED
- IMPACTED RECEIVER
- NON-IMPACTED RECEIVER
- BENEFITED RECEIVER
- RESIDENTIAL DISPLACEMENT
- COMMERCIAL DISPLACEMENT
- EXISTING ROW
- PROPOSED IMPROVEMENTS
- PROPOSED ROW
- EXISTING NEIGHBORHOOD WALLS
- VALIDATION LOCATIONS
- AMBIENT MEASUREMENT SITES

NOISE IMPACTS AND RECEIVERS

US 380
SEGMENT A

0 100 200 Feet

FIGURE A-12
NOV 2022



Legend	
	PROPOSED BARRIER
	BARRIER ANALYZED BUT NOT PROPOSED
	IMPACTED RECEIVER
	NON-IMPACTED RECEIVER
	BENEFITED RECEIVER
	RESIDENTIAL DISPLACEMENT
	COMMERCIAL DISPLACEMENT
	EXISTING ROW
	PROPOSED IMPROVEMENTS
	PROPOSED ROW
	EXISTING NEIGHBORHOOD WALLS
	VALIDATION LOCATIONS
	AMBIENT MEASUREMENT SITES

NOISE IMPACTS AND RECEIVERS

US 380
SEGMENT A

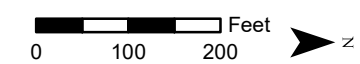
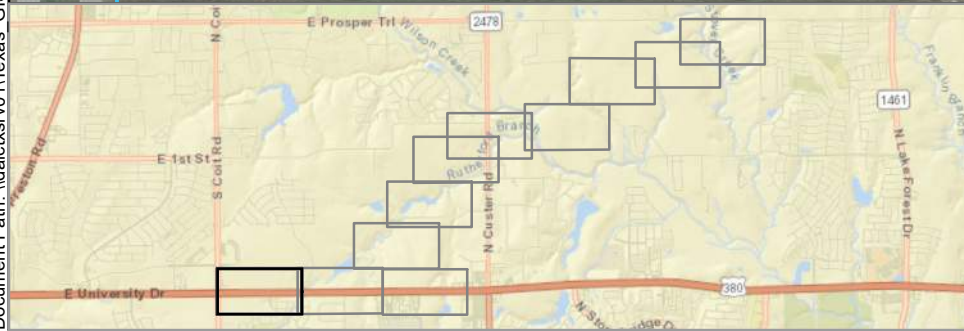
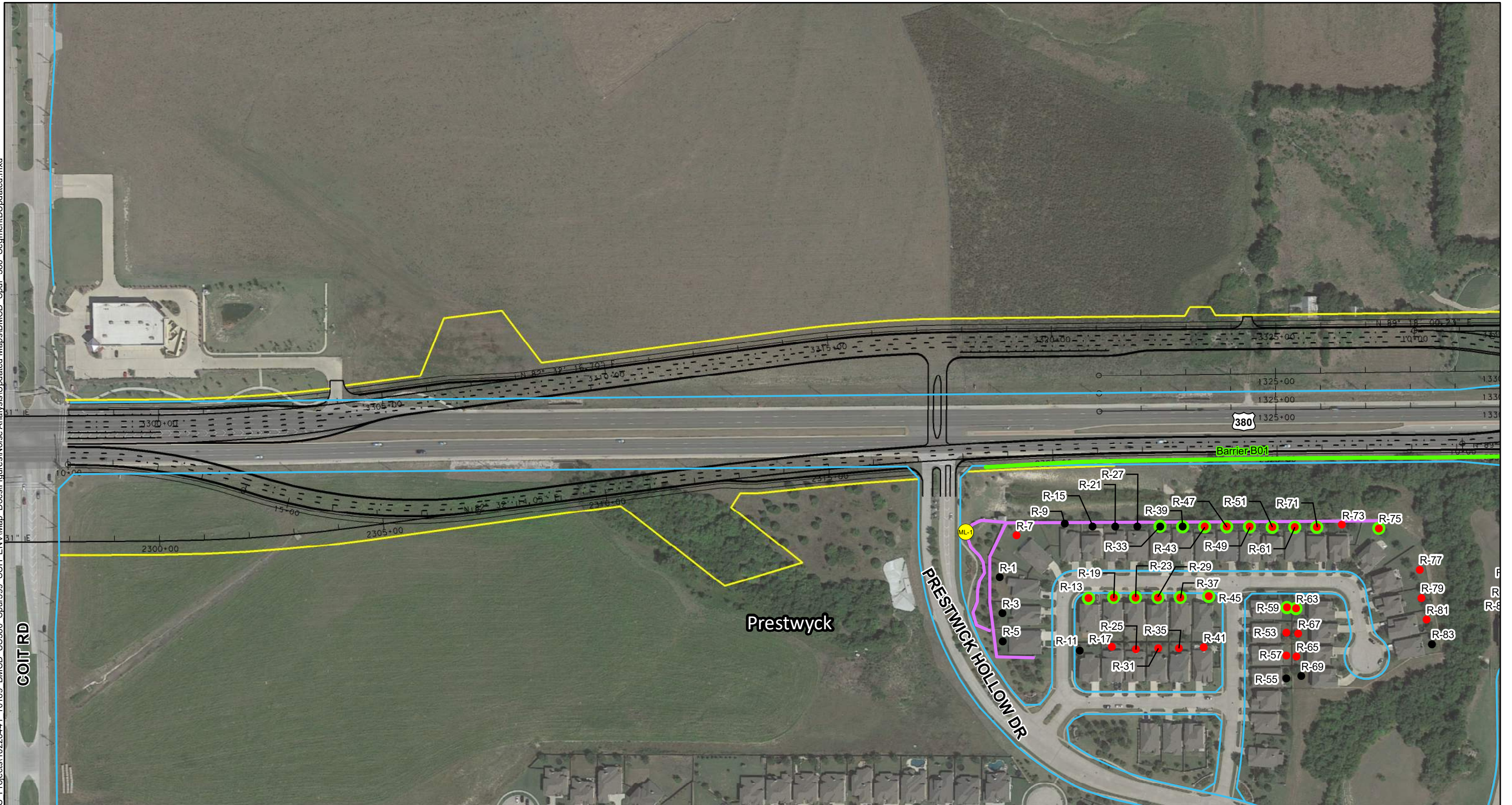


FIGURE A-13
NOV 2022



Legend

- PROPOSED BARRIER
- BARRIER ANALYZED BUT NOT PROPOSED
- IMPACTED RECEIVER
- NON-IMPACTED RECEIVER
- BENEFITED RECEIVER
- RESIDENTIAL DISPLACEMENT
- COMMERCIAL DISPLACEMENT
- EXISTING ROW
- PROPOSED IMPROVEMENTS
- PROPOSED ROW
- EXISTING NEIGHBORHOOD WALLS
- VALIDATION LOCATIONS
- AMBIENT MEASUREMENT SITES

NOISE IMPACTS AND RECEIVERS

US 380
SEGMENT B

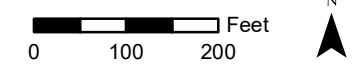
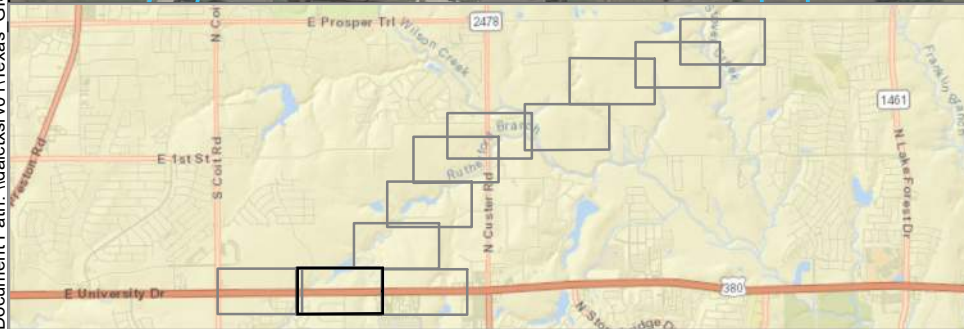
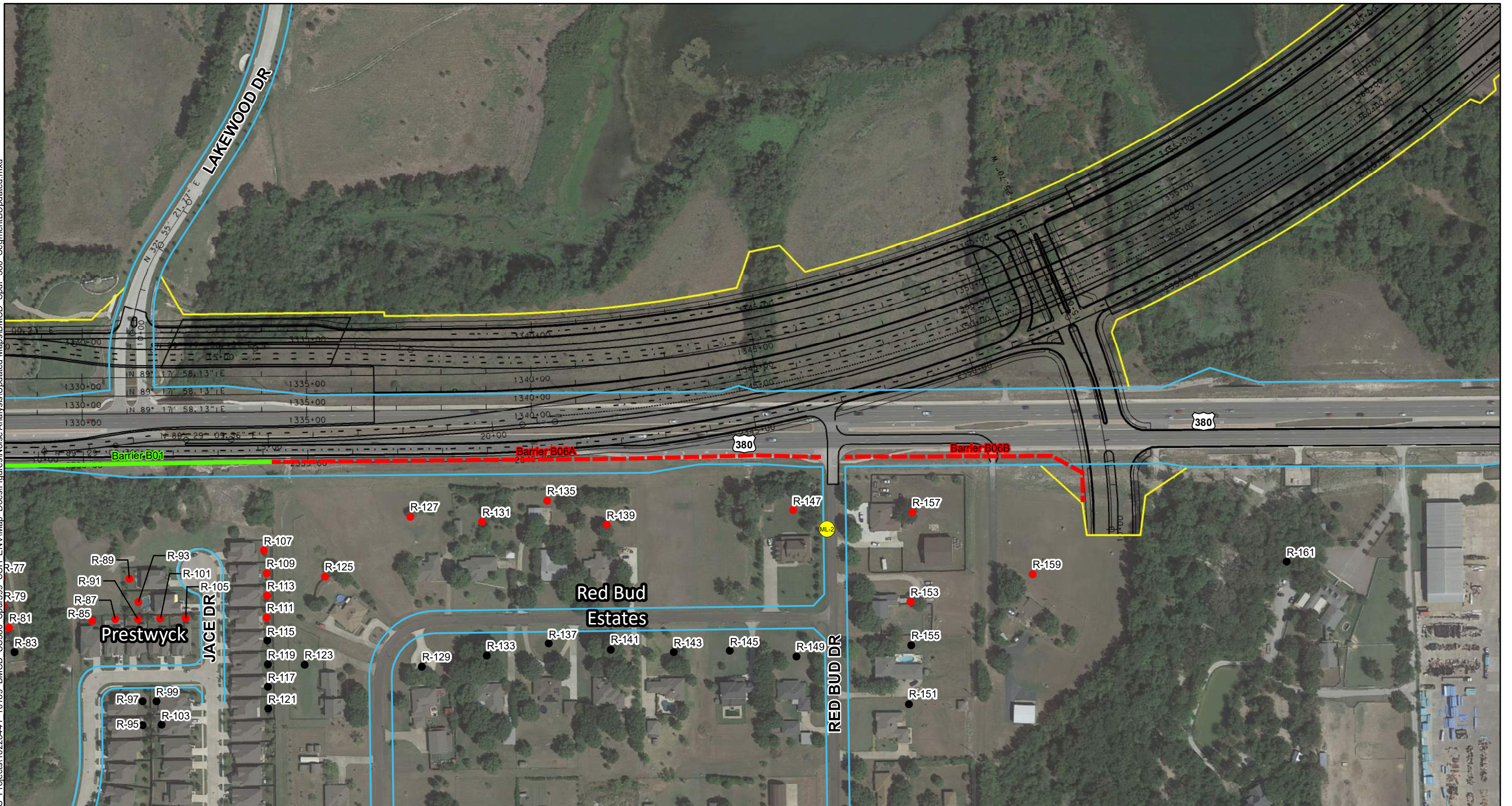


FIGURE B-1
NOV 2022



Legend

- PROPOSED BARRIER
- - - BARRIER ANALYZED BUT NOT PROPOSED
- IMPACTED RECEIVER
- NON-IMPACTED RECEIVER
- BENEFITED RECEIVER
- RESIDENTIAL DISPLACEMENT
- COMMERCIAL DISPLACEMENT
- EXISTING ROW
- PROPOSED IMPROVEMENTS
- PROPOSED ROW
- EXISTING NEIGHBORHOOD WALLS
- VALIDATION LOCATIONS
- AMBIENT MEASUREMENT SITES

NOISE IMPACTS AND RECEIVERS

US 380
SEGMENT B

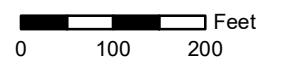
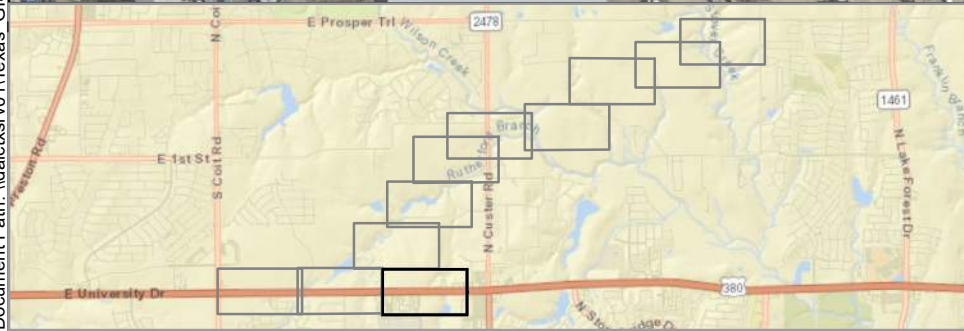
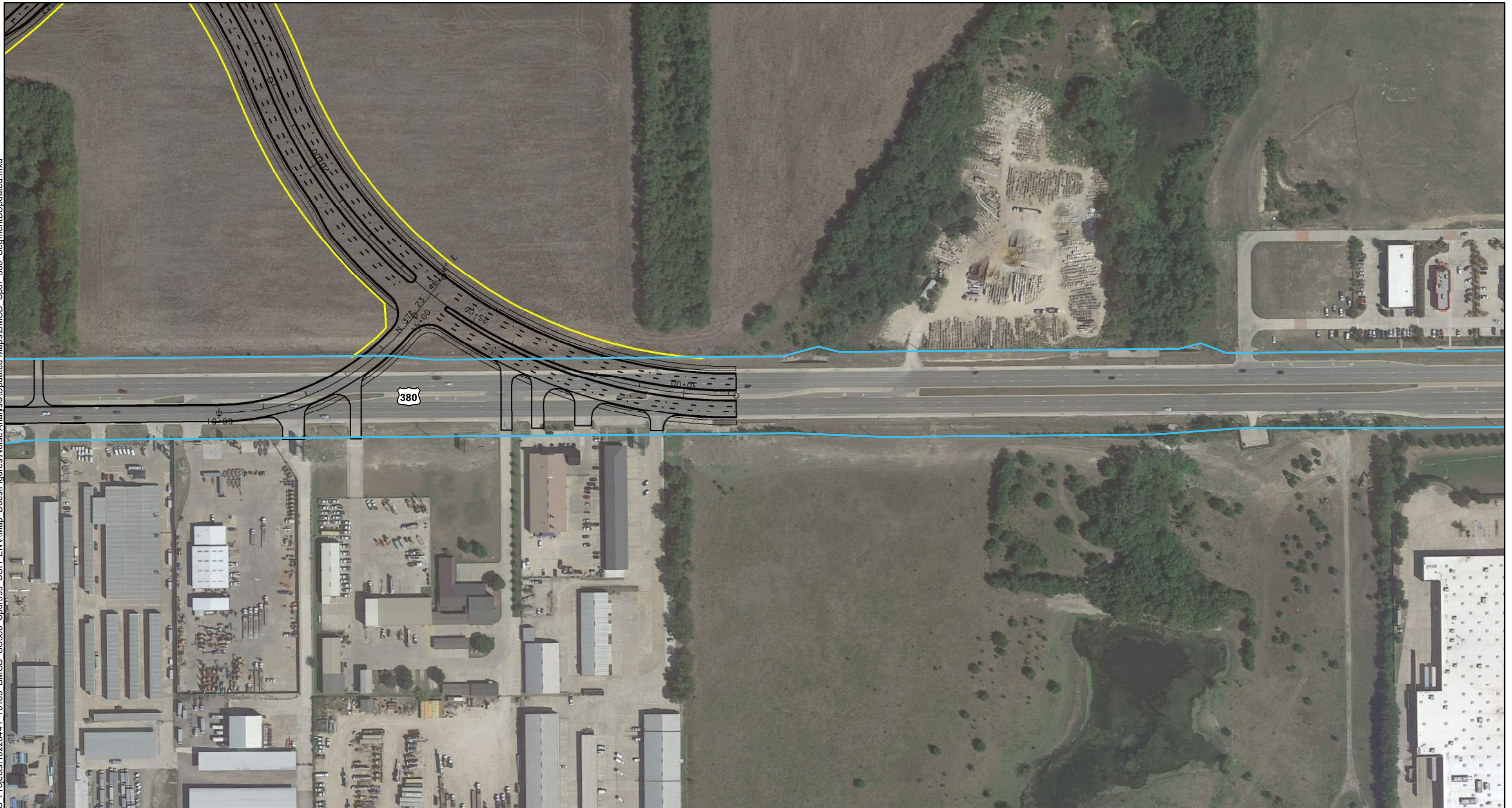


FIGURE B-2
NOV 2022



Legend

- PROPOSED BARRIER
- - - BARRIER ANALYZED BUT NOT PROPOSED
- IMPACTED RECEIVER
- NON-IMPACTED RECEIVER
- BENEFITED RECEIVER
- RESIDENTIAL DISPLACEMENT
- COMMERCIAL DISPLACEMENT
- EXISTING ROW
- PROPOSED IMPROVEMENTS
- PROPOSED ROW
- EXISTING NEIGHBORHOOD WALLS
- VALIDATION LOCATIONS
- AMBIENT MEASUREMENT SITES

NOISE IMPACTS AND RECEIVERS

US 380
SEGMENT B

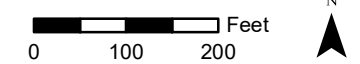
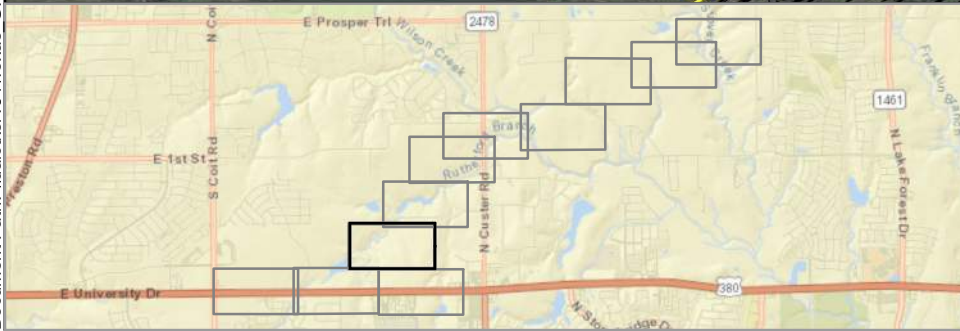


FIGURE B-3
NOV 2022



Legend

- PROPOSED BARRIER
- - - BARRIER ANALYZED BUT NOT PROPOSED
- IMPACTED RECEIVER
- NON-IMPACTED RECEIVER
- BENEFITED RECEIVER
- RESIDENTIAL DISPLACEMENT
- COMMERCIAL DISPLACEMENT
- EXISTING ROW
- PROPOSED IMPROVEMENTS
- PROPOSED ROW
- EXISTING NEIGHBORHOOD WALLS
- VALIDATION LOCATIONS
- AMBIENT MEASUREMENT SITES

NOISE IMPACTS AND RECEIVERS

US 380
SEGMENT B

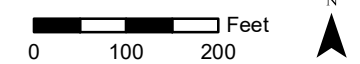
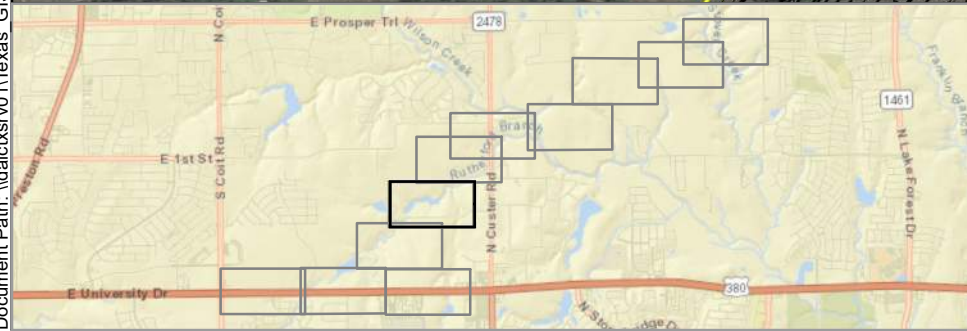


FIGURE B-4
NOV 2022



Legend

- PROPOSED BARRIER
- - - BARRIER ANALYZED BUT NOT PROPOSED
- IMPACTED RECEIVER
- NON-IMPACTED RECEIVER
- BENEFITED RECEIVER
- RESIDENTIAL DISPLACEMENT
- COMMERCIAL DISPLACEMENT
- EXISTING ROW
- PROPOSED IMPROVEMENTS
- PROPOSED ROW
- EXISTING NEIGHBORHOOD WALLS
- VALIDATION LOCATIONS
- AMBIENT MEASUREMENT SITES

NOISE IMPACTS AND RECEIVERS

US 380
SEGMENT B

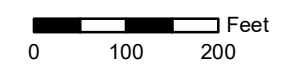
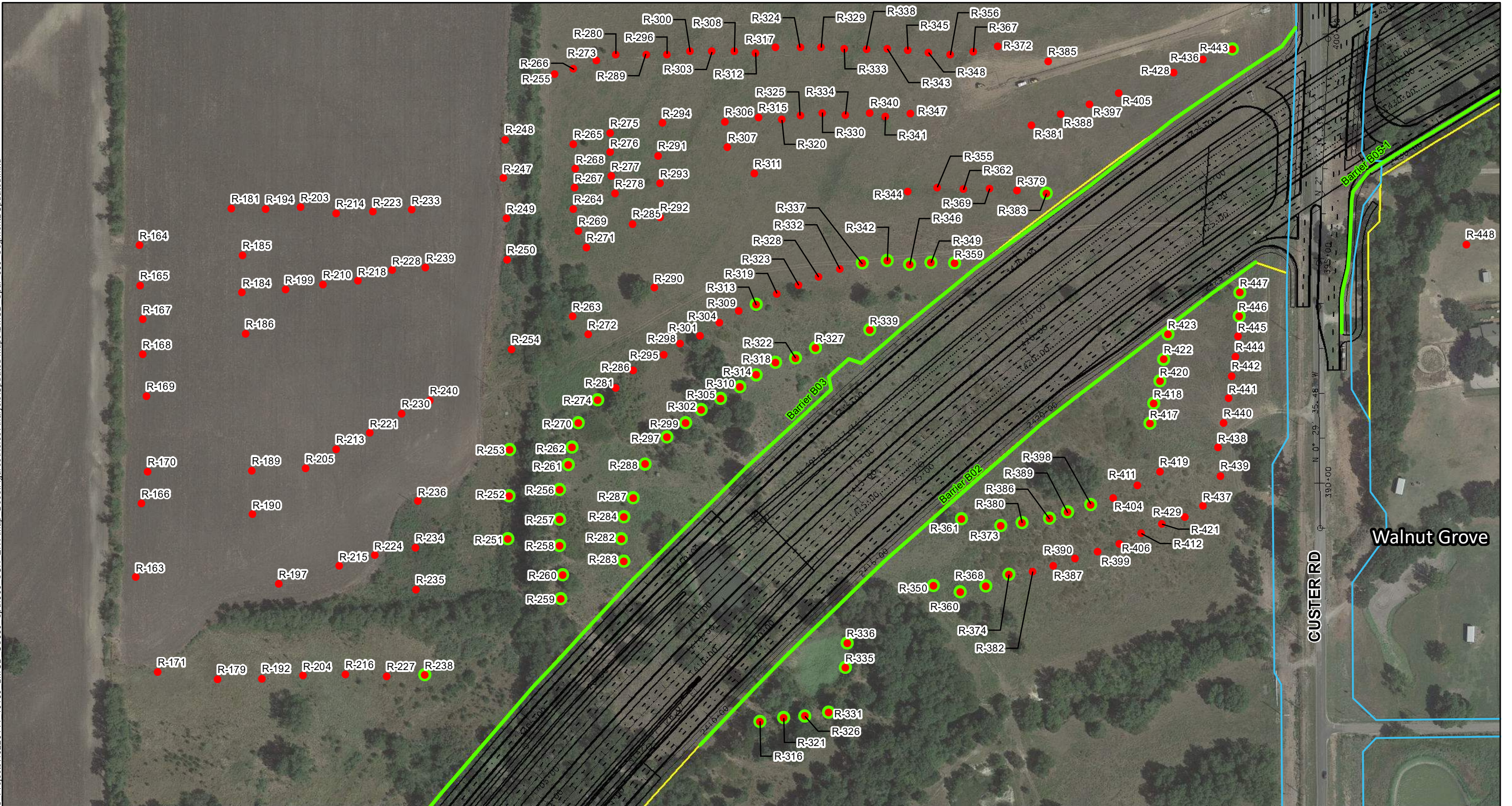


FIGURE B-5
NOV 2022



Walnut Grove

CUSTER RD

Legend

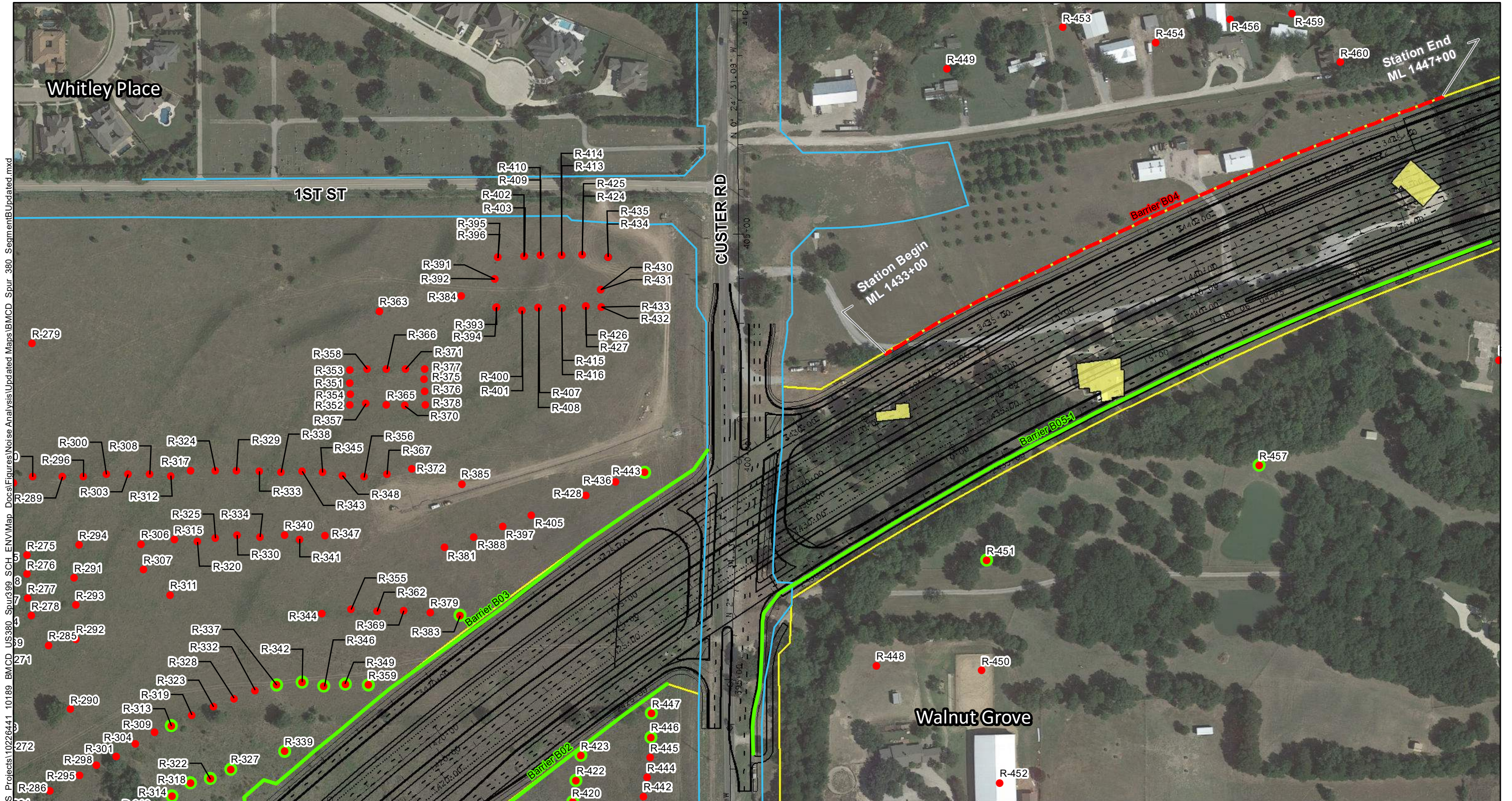
- PROPOSED BARRIER
- - - BARRIER ANALYZED BUT NOT PROPOSED
- IMPACTED RECEIVER
- NON-IMPACTED RECEIVER
- BENEFITED RECEIVER
- RESIDENTIAL DISPLACEMENT
- COMMERCIAL DISPLACEMENT
- EXISTING ROW
- PROPOSED IMPROVEMENTS
- PROPOSED ROW
- EXISTING NEIGHBORHOOD WALLS
- VALIDATION LOCATIONS
- AMBIENT MEASUREMENT SITES

NOISE IMPACTS AND RECEIVERS

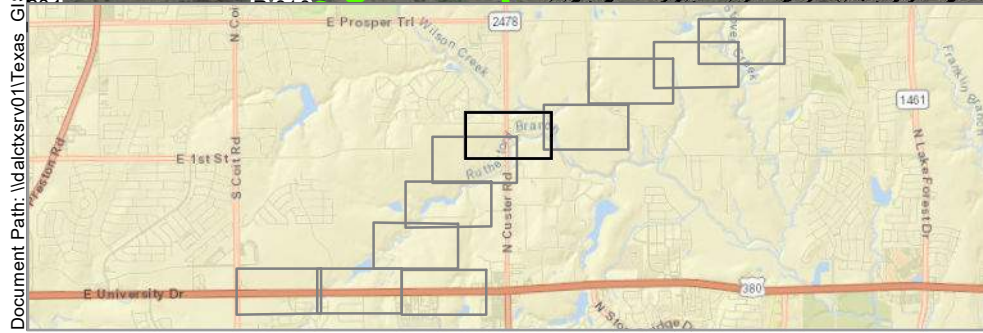
US 380
SEGMENT B

0 100 200 Feet

N



Document Path: \\dalctskv01\Texas GIS Projects\10226441_10189_BMCD_US380_Spur380_SCH_ENV\Map_Docs\Figures\Noise Analysis\Updated Maps\BMCD_Spur_380_SegmentBUpdated.mxd



Legend

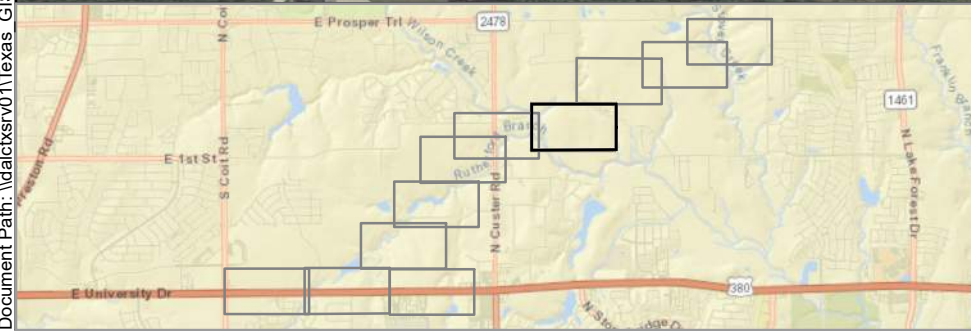
- PROPOSED BARRIER
- - - BARRIER ANALYZED BUT NOT PROPOSED
- IMPACTED RECEIVER
- NON-IMPACTED RECEIVER
- BENEFITED RECEIVER
- RESIDENTIAL DISPLACEMENT
- COMMERCIAL DISPLACEMENT
- EXISTING ROW
- PROPOSED IMPROVEMENTS
- PROPOSED ROW
- EXISTING NEIGHBORHOOD WALLS
- VALIDATION LOCATIONS
- AMBIENT MEASUREMENT SITES

NOISE IMPACTS AND RECEIVERS

US 380
SEGMENT B

0 100 200 Feet

N



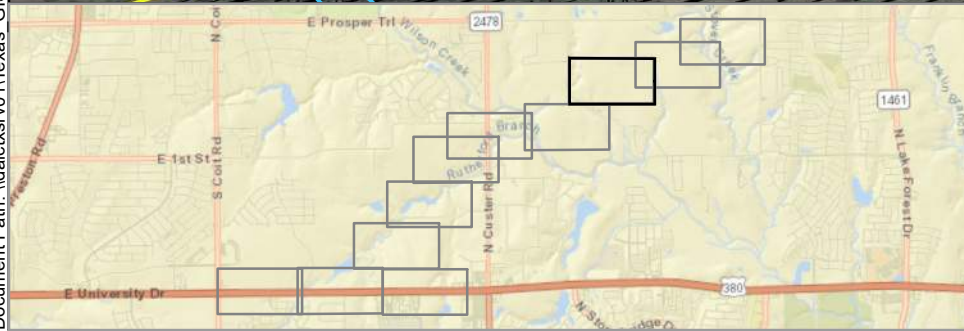
Legend	
	PROPOSED BARRIER
	BARRIER ANALYZED BUT NOT PROPOSED
	IMPACTED RECEIVER
	NON-IMPACTED RECEIVER
	BENEFITED RECEIVER
	RESIDENTIAL DISPLACEMENT
	COMMERCIAL DISPLACEMENT
	EXISTING ROW
	PROPOSED IMPROVEMENTS
	PROPOSED ROW
	EXISTING NEIGHBORHOOD WALLS
	VALIDATION LOCATIONS
	AMBIENT MEASUREMENT SITES

NOISE IMPACTS AND RECEIVERS

US 380
SEGMENT B

0 100 200 Feet

FIGURE B-8
NOV 2022



Legend

- PROPOSED BARRIER
- - - BARRIER ANALYZED BUT NOT PROPOSED
- IMPACTED RECEIVER
- NON-IMPACTED RECEIVER
- BENEFITED RECEIVER
- RESIDENTIAL DISPLACEMENT
- COMMERCIAL DISPLACEMENT
- EXISTING ROW
- PROPOSED IMPROVEMENTS
- PROPOSED ROW
- EXISTING NEIGHBORHOOD WALLS
- VALIDATION LOCATIONS
- AMBIENT MEASUREMENT SITES

NOISE IMPACTS AND RECEIVERS

US 380
SEGMENT B

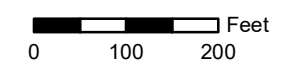
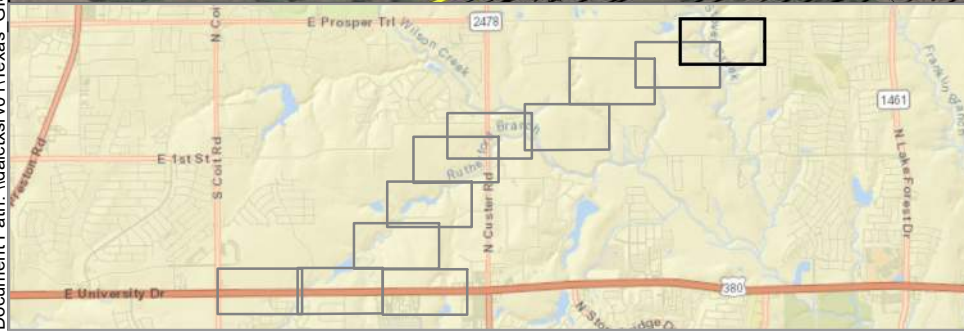
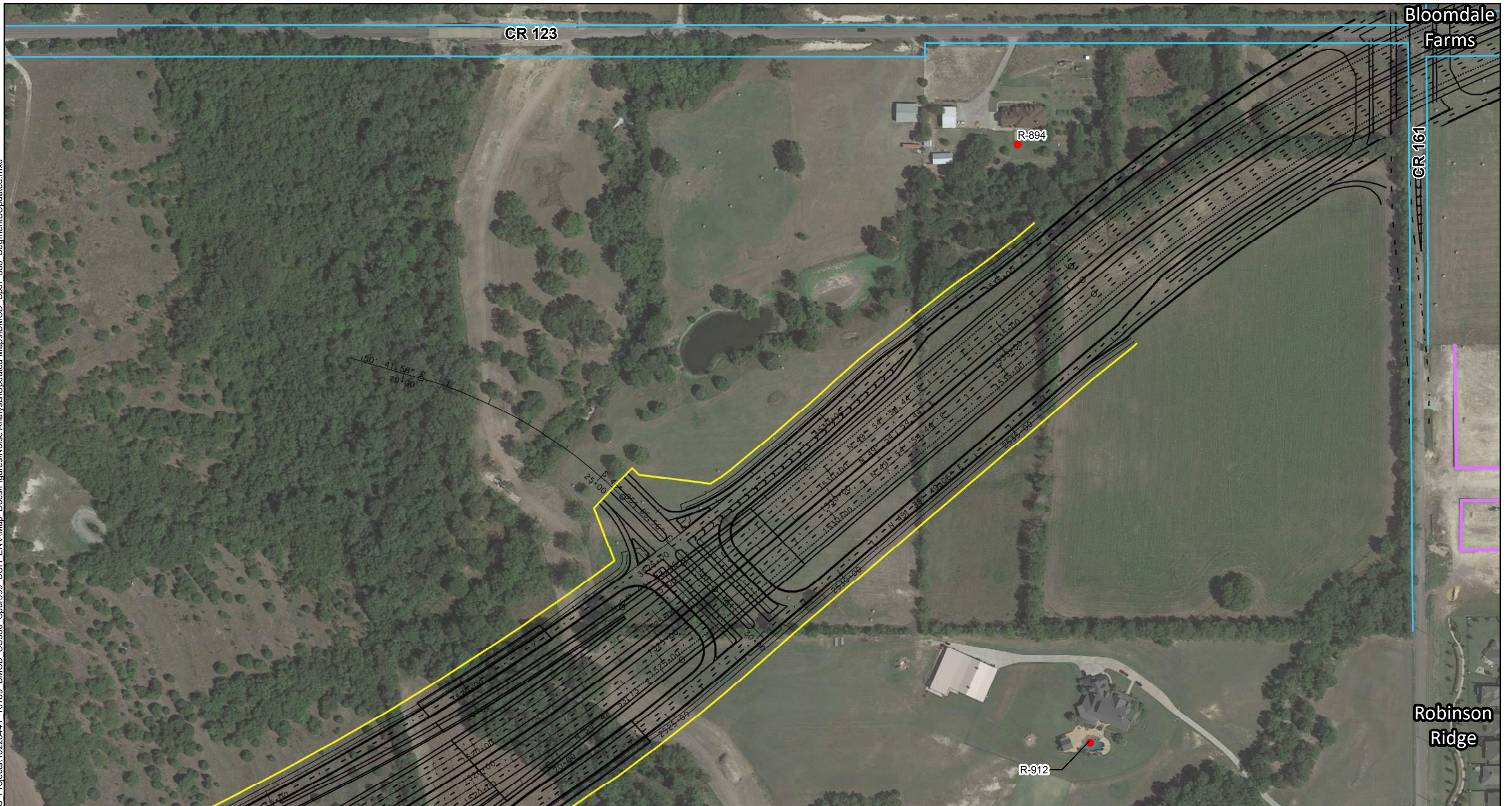


FIGURE B-9
NOV 2022





Legend

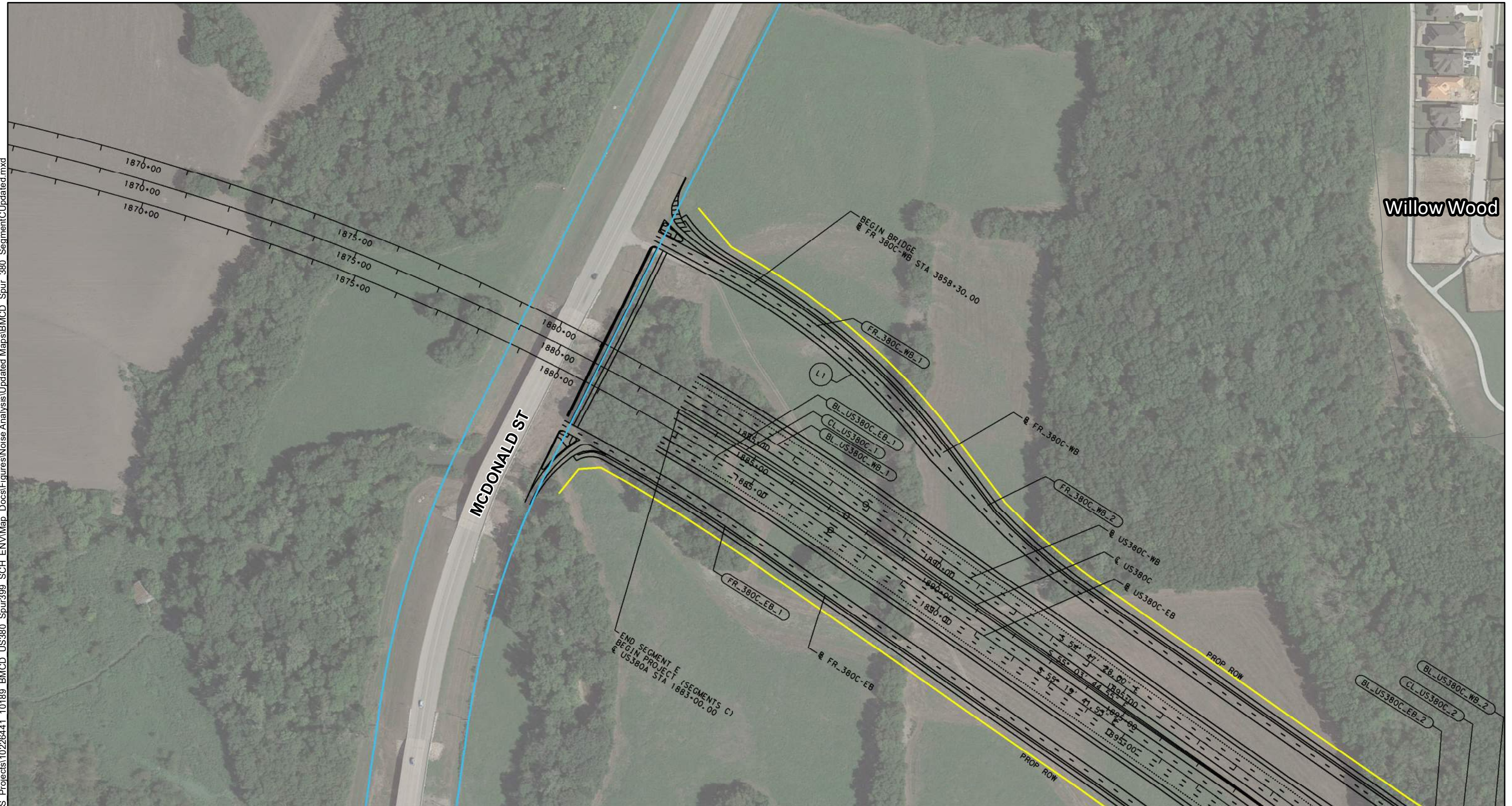
- PROPOSED BARRIER
- BARRIER ANALYZED BUT NOT PROPOSED
- IMPACTED RECEIVER
- NON-IMPACTED RECEIVER
- BENEFITED RECEIVER
- RESIDENTIAL DISPLACEMENT
- COMMERCIAL DISPLACEMENT
- EXISTING ROW
- PROPOSED IMPROVEMENTS
- PROPOSED ROW
- EXISTING NEIGHBORHOOD WALLS
- VALIDATION LOCATIONS
- AMBIENT MEASUREMENT SITES

NOISE IMPACTS AND RECEIVERS

US 380
SEGMENT B

0 100 200 Feet

N



Legend

- BARRIERS ANALYZED BUT NOT PROPOSED
- IMPACTED RECEIVER
- NON-IMPACTED RECEIVER
- RESIDENTIAL DISPLACEMENT
- COMMERCIAL DISPLACEMENT
- EXISTING ROW
- PROPOSED IMPROVEMENTS
- PROPOSED ROW
- EXISTING NEIGHBORHOOD WALLS
- VALIDATION LOCATIONS
- AMBIENT MEASUREMENT SITES

NOISE IMPACTS AND RECEIVERS

US 380
SEGMENT C

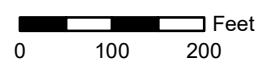
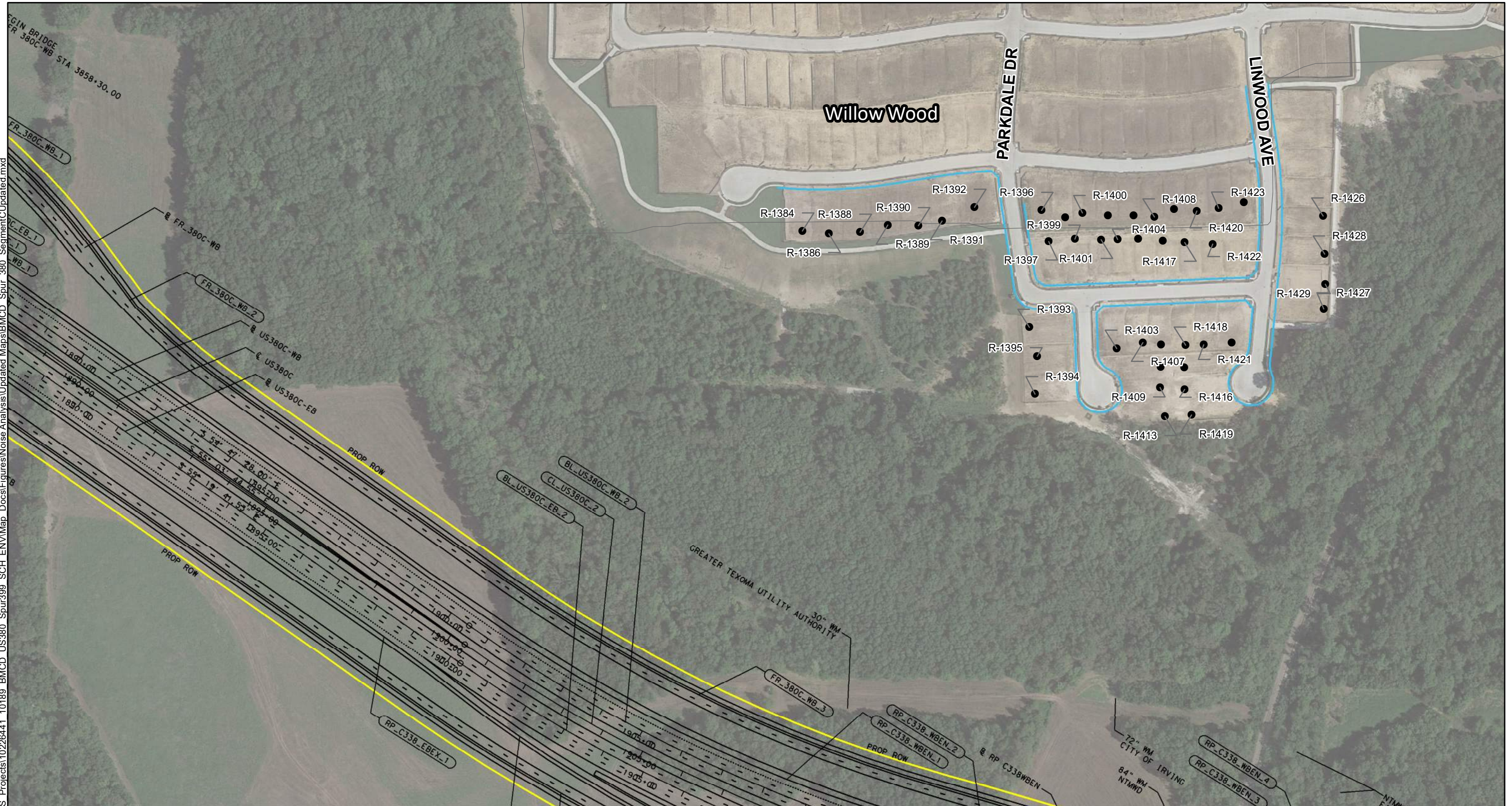


FIGURE C-1
NOV 2022

Document Path: \\dalactsvr01\Texas GIS Projects\10226441_10189_BMCD_US380_Spur399_SCH_ENV\Map Docs\Figures\Noise Analysis\Updated Maps\BMCD_Spur_380_SegmentC\Updated.mxd

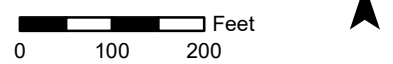


Legend

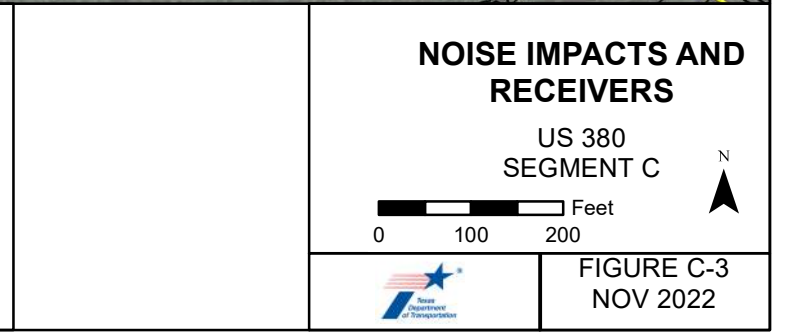
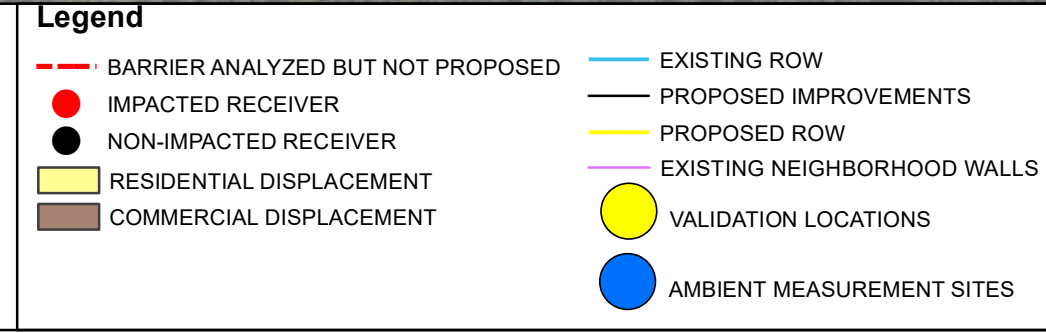
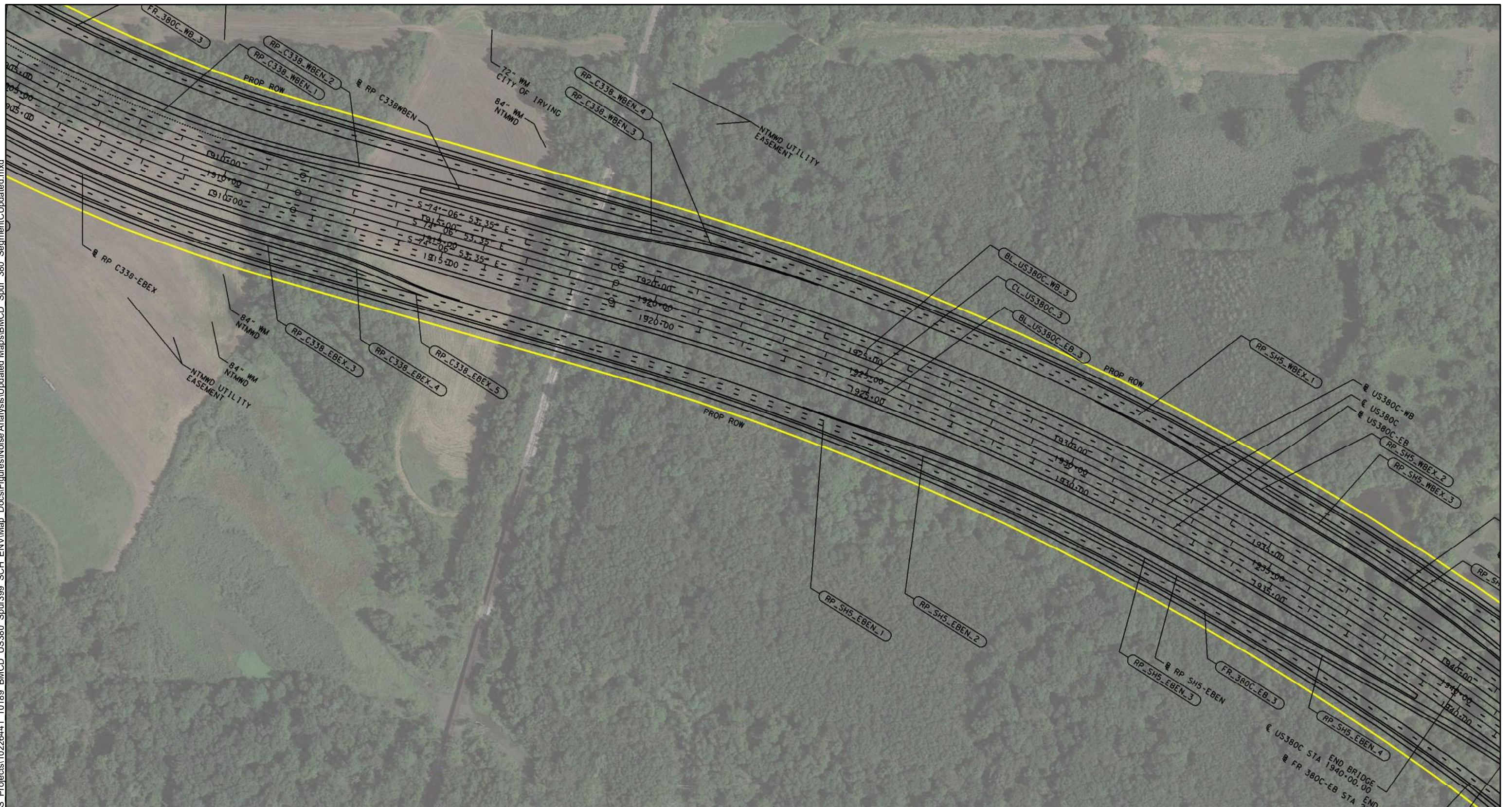
- BARRIER ANALYZED BUT NOT PROPOSED
- IMPACTED RECEIVER
- NON-IMPACTED RECEIVER
- RESIDENTIAL DISPLACEMENT
- COMMERCIAL DISPLACEMENT
- EXISTING ROW
- PROPOSED IMPROVEMENTS
- PROPOSED ROW
- EXISTING NEIGHBORHOOD WALLS
- VALIDATION LOCATIONS
- AMBIENT MEASUREMENT SITES

NOISE IMPACTS AND RECEIVERS

US 380
SEGMENT C



Document Path: \\dalctsvr01\Texas GIS Projects\10226441_10189_BMCD_US380_Spur399_SCH ENV\Map Docs\Figures\Noise Analysis\Updated Maps\BMCD_Spur_380_SegmentC\Updated.mxd





Legend

- BARRIER ANALYZED BUT NOT PROPOSED
- IMPACTED RECEIVER
- NON-IMPACTED RECEIVER
- RESIDENTIAL DISPLACEMENT
- COMMERCIAL DISPLACEMENT
- EXISTING ROW
- PROPOSED IMPROVEMENTS
- PROPOSED ROW
- EXISTING NEIGHBORHOOD WALLS
- VALIDATION LOCATIONS
- AMBIENT MEASUREMENT SITES

NOISE IMPACTS AND RECEIVERS

US 380
SEGMENT C

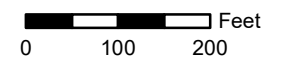


FIGURE C-4
NOV 2022



Legend

- BARRIER ANALYZED BUT NOT PROPOSED
- IMPACTED RECEIVER
- NON-IMPACTED RECEIVER
- RESIDENTIAL DISPLACEMENT
- COMMERCIAL DISPLACEMENT
- EXISTING ROW
- PROPOSED IMPROVEMENTS
- PROPOSED ROW
- EXISTING NEIGHBORHOOD WALLS
- VALIDATION LOCATIONS
- AMBIENT MEASUREMENT SITES

NOISE IMPACTS AND RECEIVERS

US 380
SEGMENT C

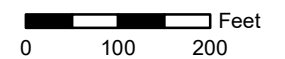
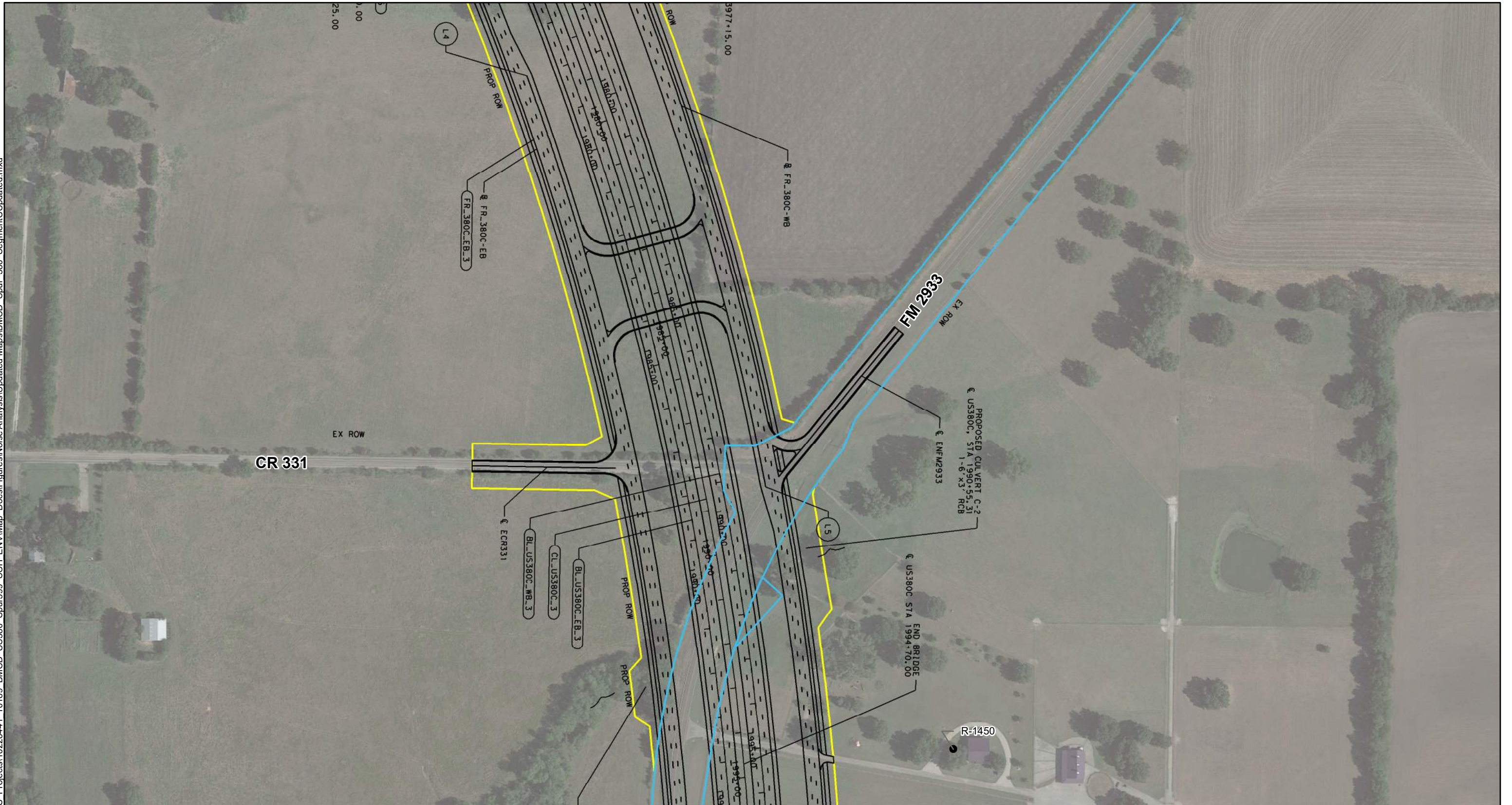


FIGURE C-5
NOV 2022



Legend

- BARRIER ANALYZED BUT NOT PROPOSED
- IMPACTED RECEIVER
- NON-IMPACTED RECEIVER
- RESIDENTIAL DISPLACEMENT
- COMMERCIAL DISPLACEMENT
- EXISTING ROW
- PROPOSED IMPROVEMENTS
- PROPOSED ROW
- EXISTING NEIGHBORHOOD WALLS
- VALIDATION LOCATIONS
- AMBIENT MEASUREMENT SITES

NOISE IMPACTS AND RECEIVERS

US 380
SEGMENT C

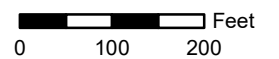
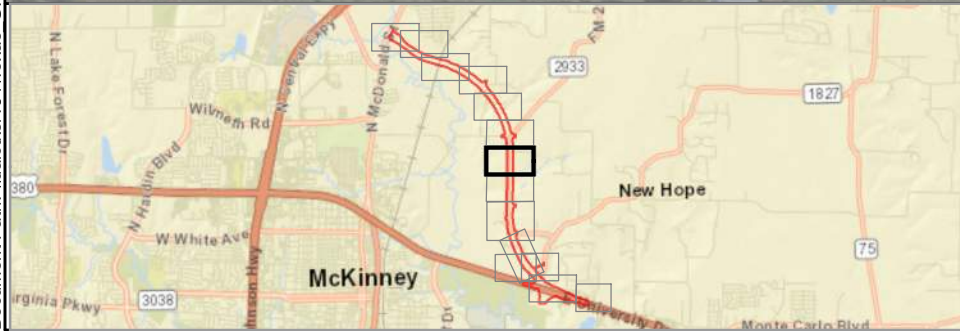


FIGURE C-6
NOV 2022



Legend

- BARRIER ANALYZED BUT NOT PROPOSED
- IMPACTED RECEIVER
- NON-IMPACTED RECEIVER
- RESIDENTIAL DISPLACEMENT
- COMMERCIAL DISPLACEMENT
- EXISTING ROW
- PROPOSED IMPROVEMENTS
- PROPOSED ROW
- EXISTING NEIGHBORHOOD WALLS
- VALIDATION LOCATIONS
- AMBIENT MEASUREMENT SITES

NOISE IMPACTS AND RECEIVERS

US 380
SEGMENT C

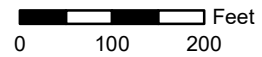
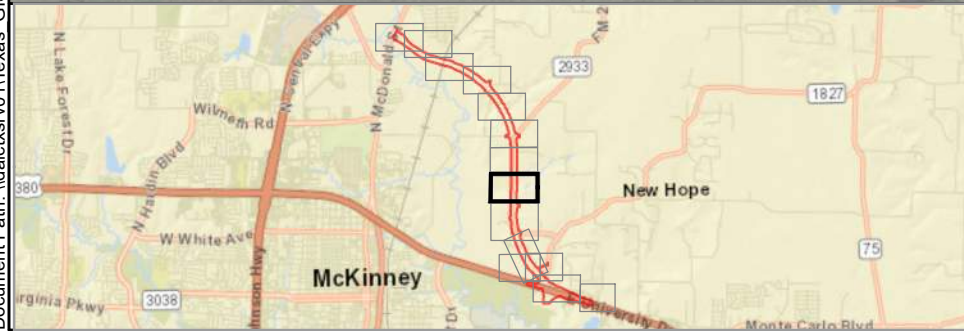
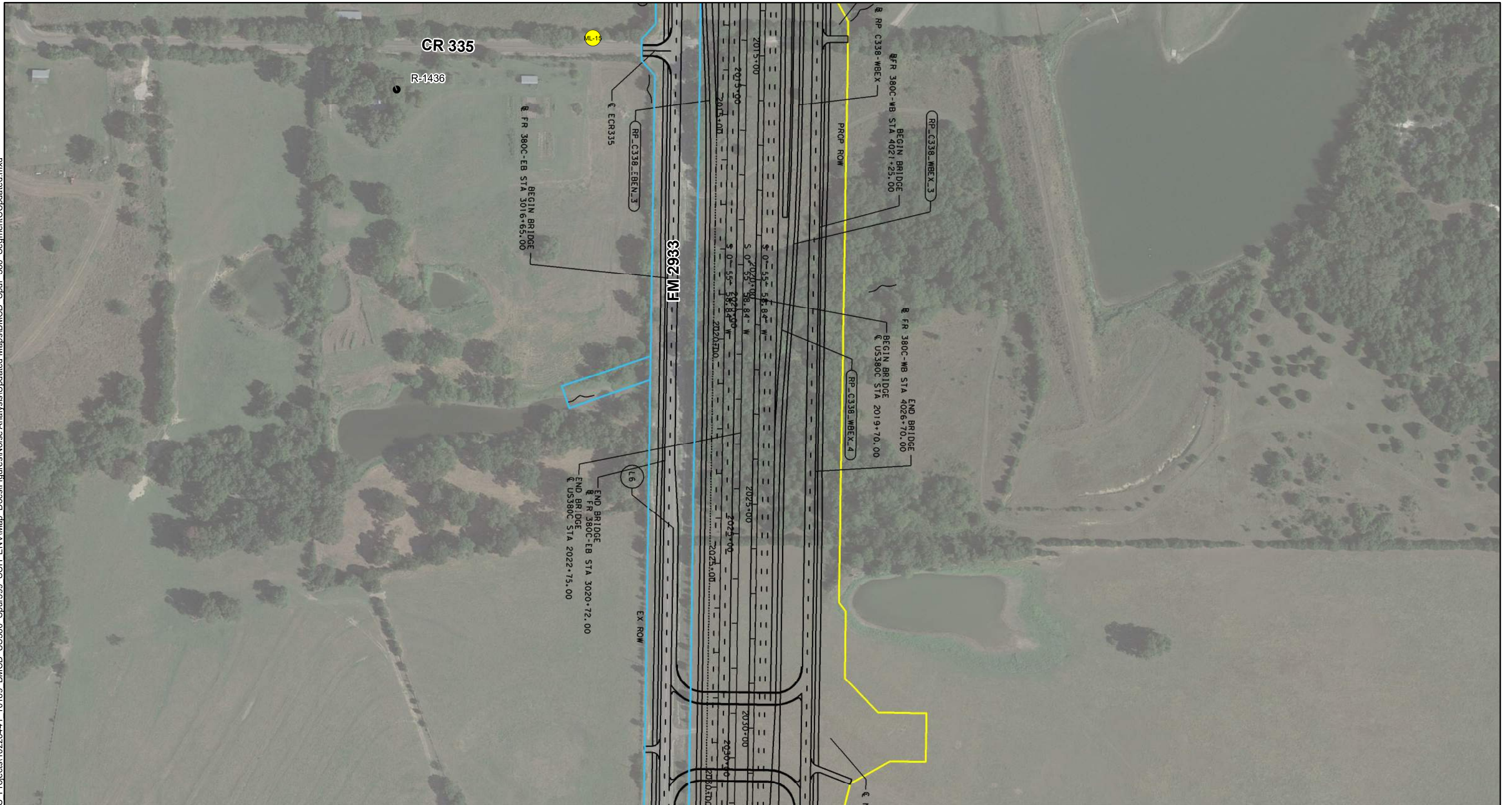


FIGURE C-7
NOV 2022



Legend

- BARRIER ANALYZED BUT NOT PROPOSED
- IMPACTED RECEIVER
- NON-IMPACTED RECEIVER
- RESIDENTIAL DISPLACEMENT
- COMMERCIAL DISPLACEMENT
- EXISTING ROW
- PROPOSED IMPROVEMENTS
- PROPOSED ROW
- EXISTING NEIGHBORHOOD WALLS
- VALIDATION LOCATIONS
- AMBIENT MEASUREMENT SITES

NOISE IMPACTS AND RECEIVERS

US 380
SEGMENT C

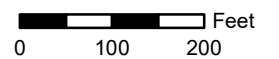
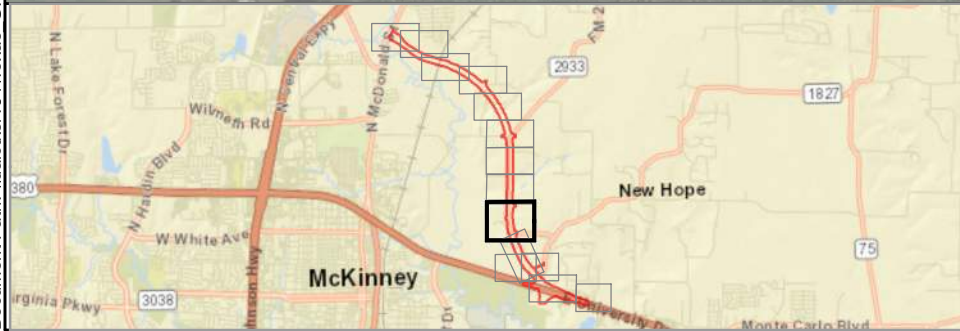
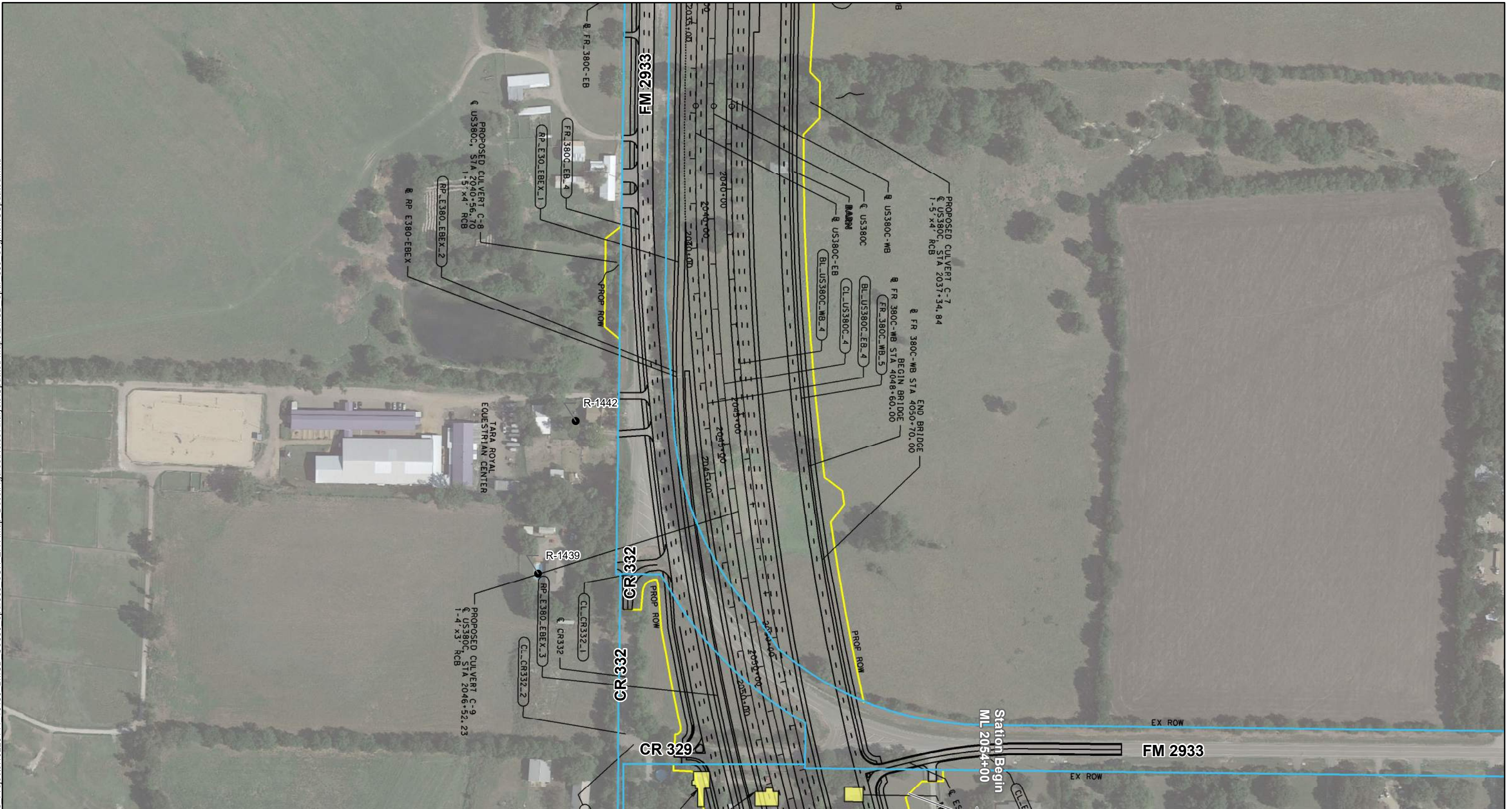


FIGURE C-8
NOV 2022



Legend

- BARRIER ANALYZED BUT NOT PROPOSED
- IMPACTED RECEIVER
- NON-IMPACTED RECEIVER
- RESIDENTIAL DISPLACEMENT
- COMMERCIAL DISPLACEMENT
- EXISTING ROW
- PROPOSED IMPROVEMENTS
- PROPOSED ROW
- EXISTING NEIGHBORHOOD WALLS
- VALIDATION LOCATIONS
- AMBIENT MEASUREMENT SITES

NOISE IMPACTS AND RECEIVERS

US 380
SEGMENT C

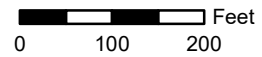
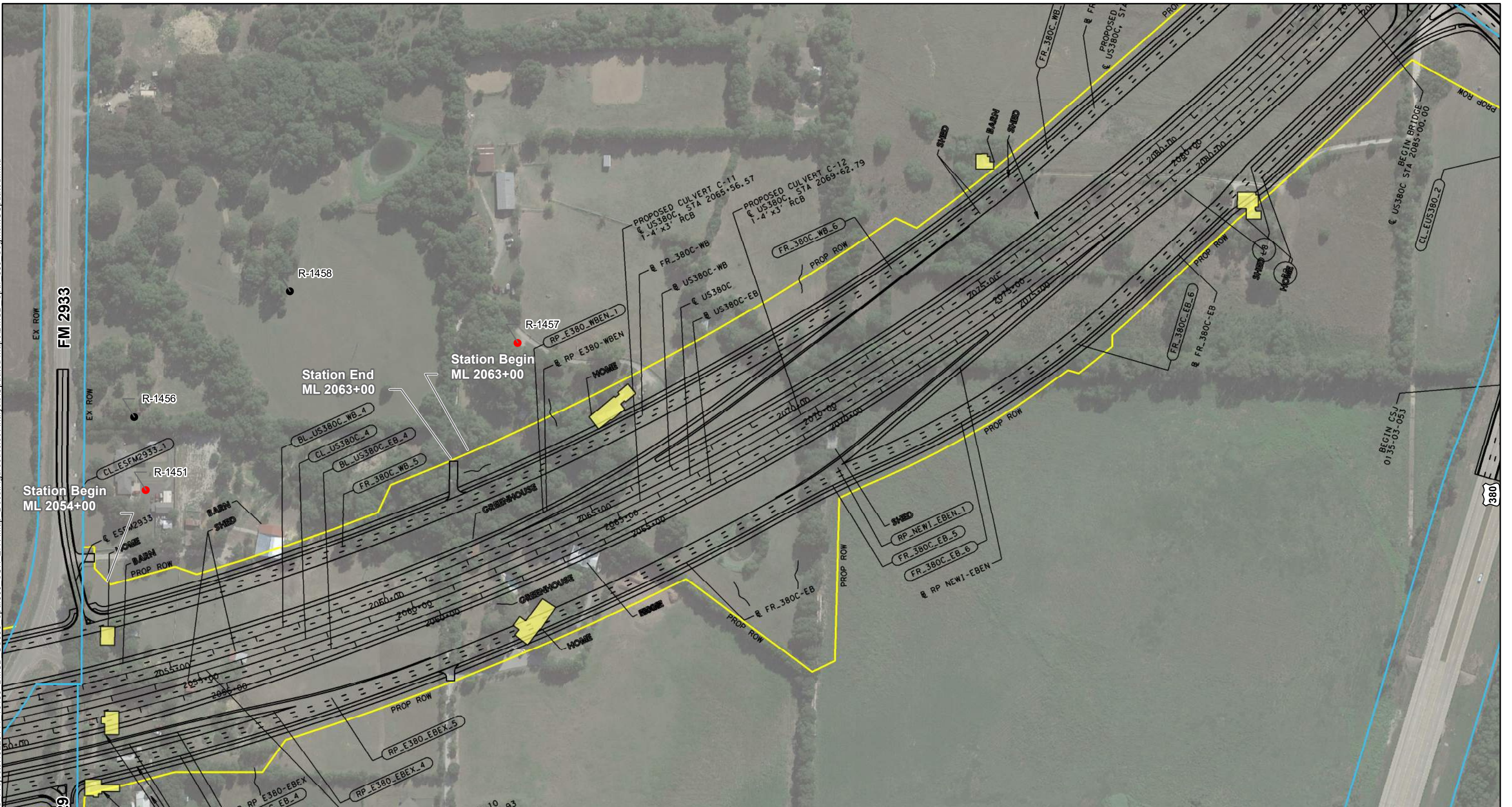


FIGURE C-9
NOV 2022



Legend

- BARRIER ANALYZED BUT NOT PROPOSED
- IMPACTED RECEIVER
- NON-IMPACTED RECEIVER
- RESIDENTIAL DISPLACEMENT
- COMMERCIAL DISPLACEMENT
- EXISTING ROW
- PROPOSED IMPROVEMENTS
- PROPOSED ROW
- EXISTING NEIGHBORHOOD WALLS
- VALIDATION LOCATIONS
- AMBIENT MEASUREMENT SITES

NOISE IMPACTS AND RECEIVERS

US 380
SEGMENT C

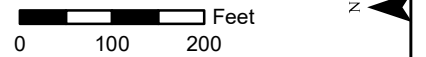
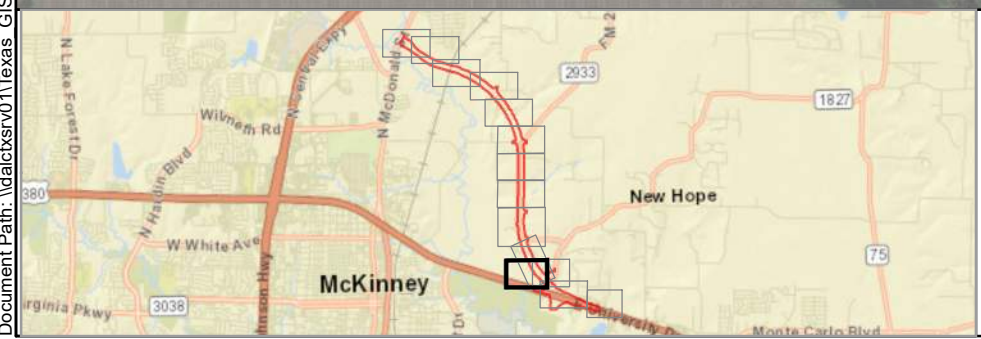


FIGURE C-10
NOV 2022



Legend

- BARRIER ANALYZED BUT NOT PROPOSED
- IMPACTED RECEIVER
- NON-IMPACTED RECEIVER
- RESIDENTIAL DISPLACEMENT
- COMMERCIAL DISPLACEMENT
- EXISTING ROW
- PROPOSED IMPROVEMENTS
- PROPOSED ROW
- EXISTING NEIGHBORHOOD WALLS
- VALIDATION LOCATIONS
- AMBIENT MEASUREMENT SITES

NOISE IMPACTS AND RECEIVERS

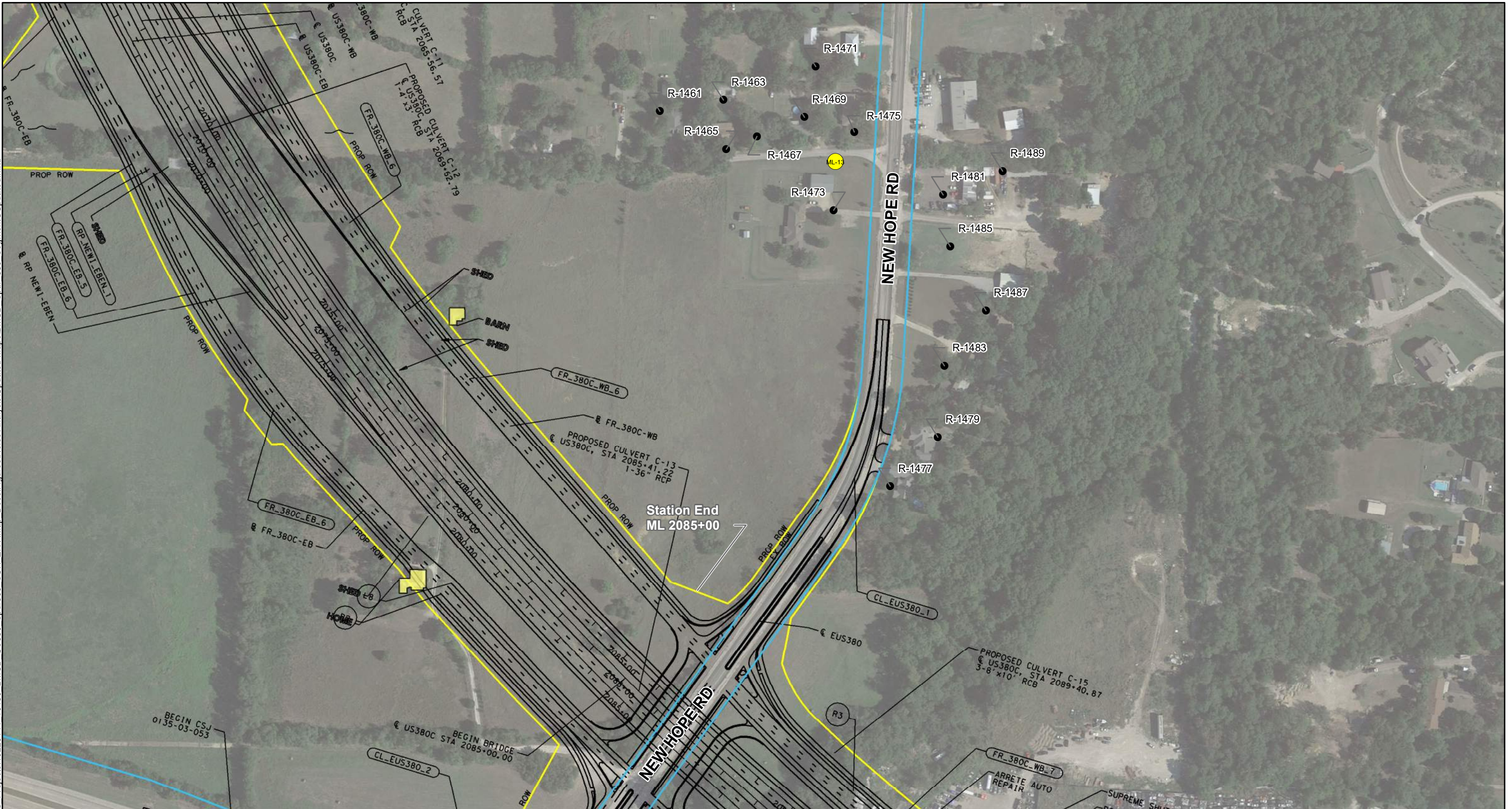
US 380
SEGMENT C

0 100 200

Feet

FIGURE C-11
NOV 2022

Document Path: \\dalctsr\01\Texas GIS Projects\10226441_10189_BMCD_US380_Spur399_SCH_ENV\Map_Docs\Figures\Noise Analysis\Updated Maps\BMCD_Spur_380_SegmentC\Updated.mxd



Legend

- BARRIER ANALYZED BUT NOT PROPOSED
- IMPACTED RECEIVER
- NON-IMPACTED RECEIVER
- RESIDENTIAL DISPLACEMENT
- COMMERCIAL DISPLACEMENT
- EXISTING ROW
- PROPOSED IMPROVEMENTS
- PROPOSED ROW
- EXISTING NEIGHBORHOOD WALLS
- VALIDATION LOCATIONS
- AMBIENT MEASUREMENT SITES

NOISE IMPACTS AND RECEIVERS

US 380
SEGMENT C

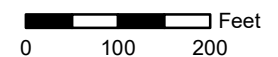
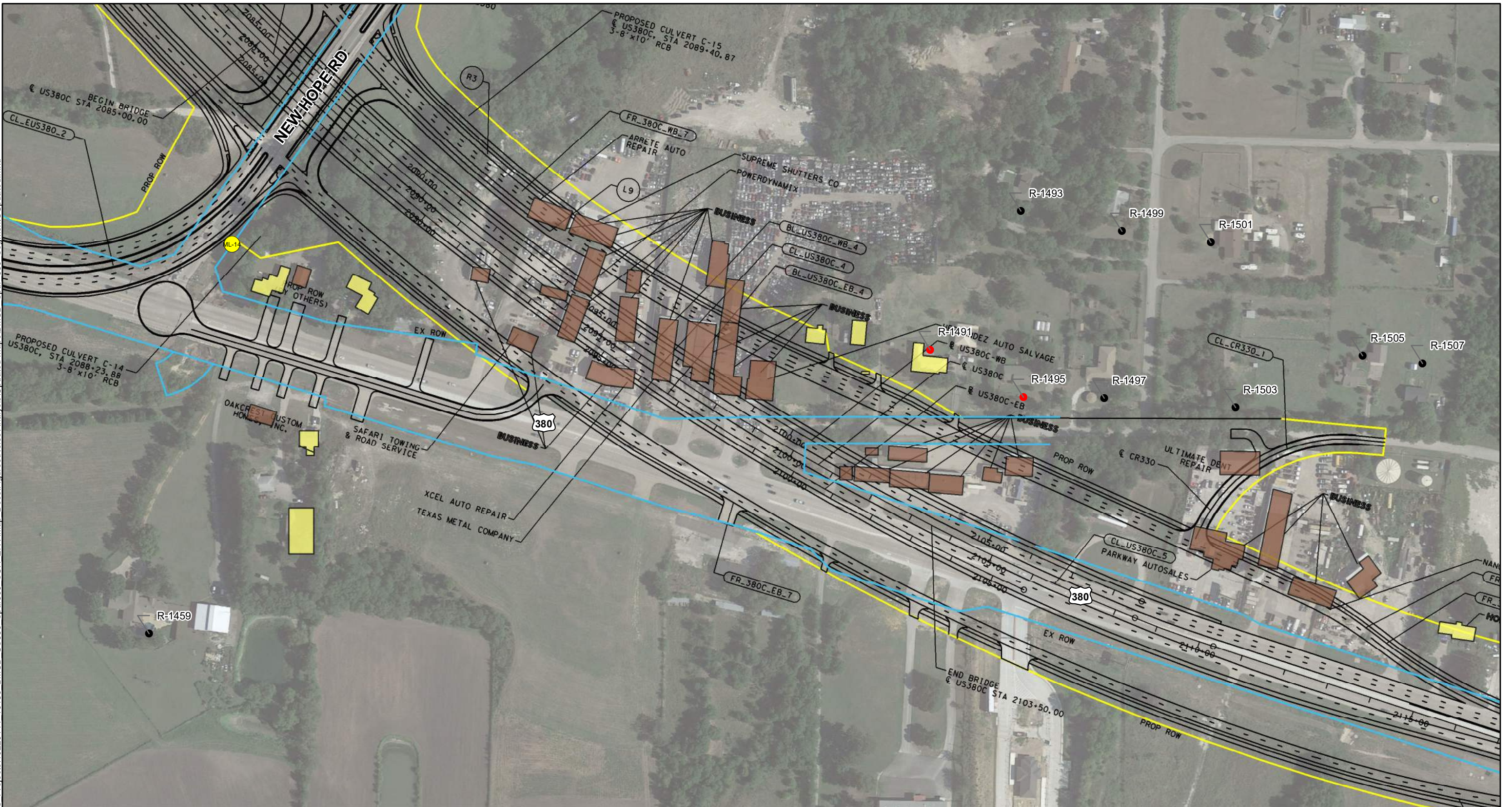


FIGURE C-12
NOV 2022



Legend

- BARRIER ANALYZED BUT NOT PROPOSED
- IMPACTED RECEIVER
- NON-IMPACTED RECEIVER
- RESIDENTIAL DISPLACEMENT
- COMMERCIAL DISPLACEMENT
- EXISTING ROW
- PROPOSED IMPROVEMENTS
- PROPOSED ROW
- EXISTING NEIGHBORHOOD WALLS
- VALIDATION LOCATIONS
- AMBIENT MEASUREMENT SITES

NOISE IMPACTS AND RECEIVERS

US 380
SEGMENT C

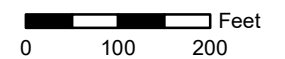


FIGURE C-13
NOV 2022

Document Path: \\dalactxrv01\Texas GIS Projects\10226441_10189_BMCD_US380_Spur399_SCH_ENV\Map Docs\Figures\Noise Analysis\Updated Maps\BMCD_Spur_380_SegmentC\Updated.mxd



Legend

- BARRIER ANALYZED BUT NOT PROPOSED
- IMPACTED RECEIVER
- NON-IMPACTED RECEIVER
- RESIDENTIAL DISPLACEMENT
- COMMERCIAL DISPLACEMENT
- EXISTING ROW
- PROPOSED IMPROVEMENTS
- PROPOSED ROW
- EXISTING NEIGHBORHOOD WALLS
- VALIDATION LOCATIONS
- AMBIENT MEASUREMENT SITES

NOISE IMPACTS AND RECEIVERS

US 380
SEGMENT C

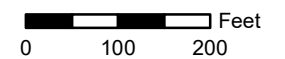
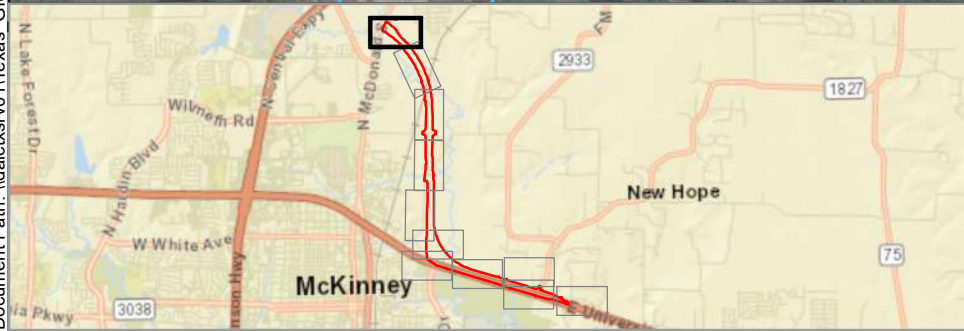


FIGURE C-14
NOV 2022



Legend

- BARRIER ANALYZED BUT NOT PROPOSED
- IMPACTED RECEIVER
- NON-IMPACTED RECEIVER
- RESIDENTIAL DISPLACEMENT
- COMMERCIAL DISPLACEMENT
- EXISTING ROW
- PROPOSED IMPROVEMENTS
- PROPOSED ROW
- EXISTING NEIGHBORHOOD WALLS
- VALIDATION LOCATIONS
- AMBIENT MEASUREMENT SITES

NOISE IMPACTS AND RECEIVERS

US 380
SEGMENT D

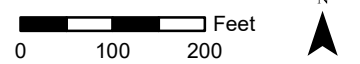
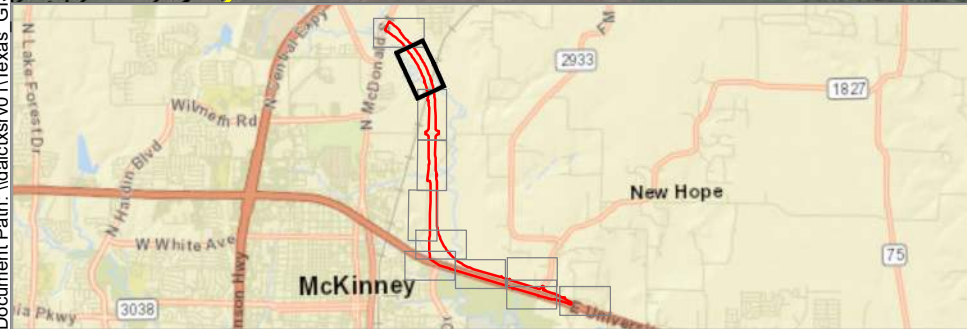


FIGURE D-1
NOV 2022



Legend

- BARRIER ANALYZED BUT NOT PROPOSED
- IMPACTED RECEIVER
- NON-IMPACTED RECEIVER
- RESIDENTIAL DISPLACEMENT
- COMMERCIAL DISPLACEMENT
- EXISTING ROW
- PROPOSED IMPROVEMENTS
- PROPOSED ROW
- EXISTING NEIGHBORHOOD WALLS
- VALIDATION LOCATIONS
- AMBIENT MEASUREMENT SITES

NOISE IMPACTS AND RECEIVERS

US 380
SEGMENT D



FIGURE D-2
NOV 2022



Legend

- BARRIER ANALYZED BUT NOT PROPOSED
- IMPACTED RECEIVER
- NON-IMPACTED RECEIVER
- RESIDENTIAL DISPLACEMENT
- COMMERCIAL DISPLACEMENT
- EXISTING ROW
- PROPOSED IMPROVEMENTS
- PROPOSED ROW
- EXISTING NEIGHBORHOOD WALLS
- VALIDATION LOCATIONS
- AMBIENT MEASUREMENT SITES

NOISE IMPACTS AND RECEIVERS

US 380
SEGMENT D

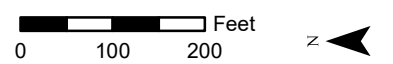
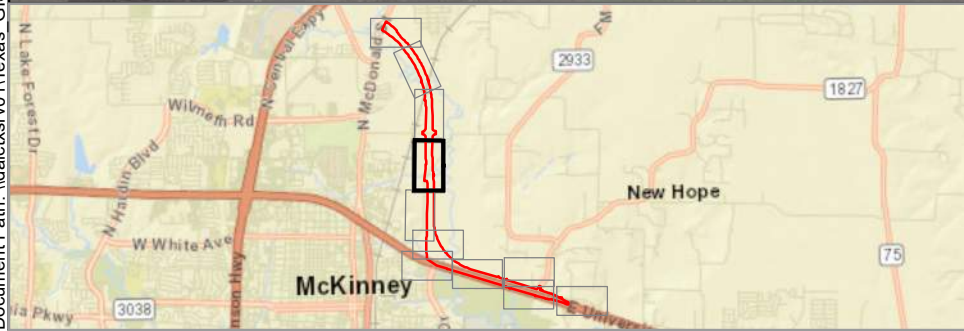


FIGURE D-3
NOV 2022



Legend

- BARRIER ANALYZED BUT NOT PROPOSED
- IMPACTED RECEIVER
- NON-IMPACTED RECEIVER
- RESIDENTIAL DISPLACEMENT
- COMMERCIAL DISPLACEMENT
- EXISTING ROW
- PROPOSED IMPROVEMENTS
- PROPOSED ROW
- EXISTING NEIGHBORHOOD WALLS
- VALIDATION LOCATIONS
- AMBIENT MEASUREMENT SITES

NOISE IMPACTS AND RECEIVERS

US 380
SEGMENT D

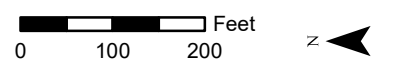
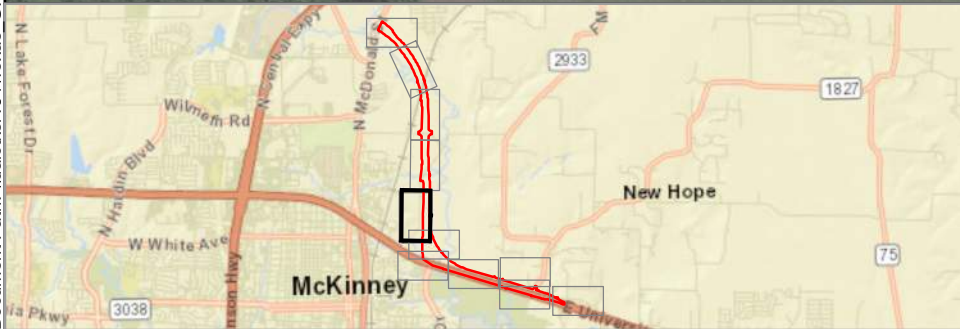
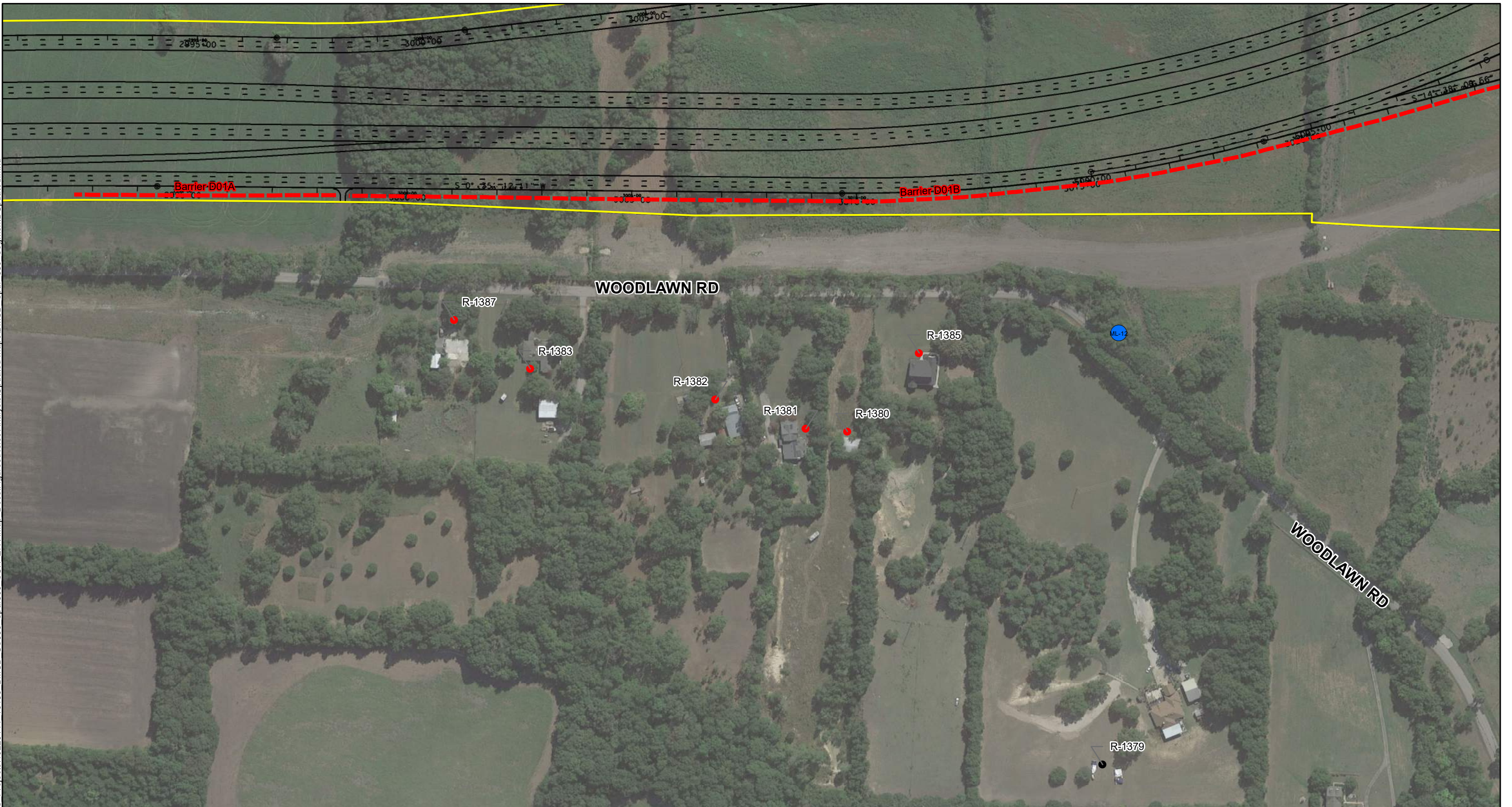


FIGURE D-4
NOV 2022



Legend

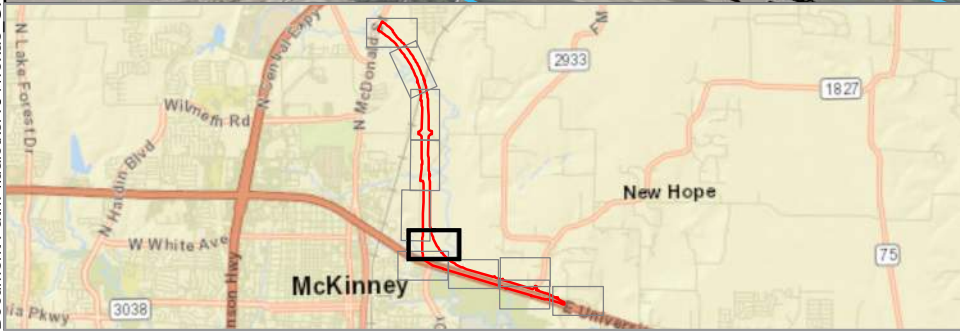
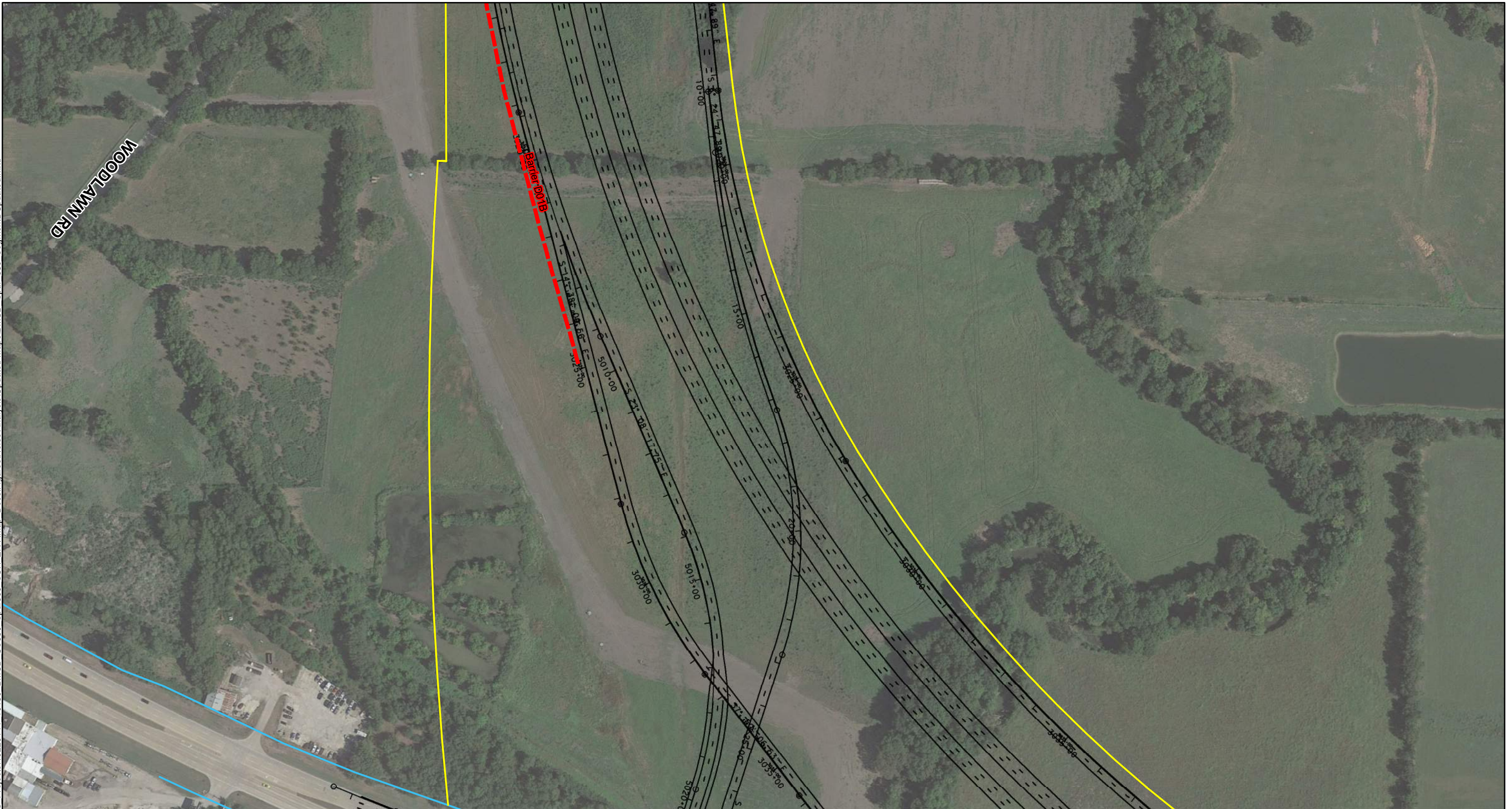
- BARRIER ANALYZED BUT NOT PROPOSED
- IMPACTED RECEIVER
- NON-IMPACTED RECEIVER
- RESIDENTIAL DISPLACEMENT
- COMMERCIAL DISPLACEMENT
- EXISTING ROW
- PROPOSED IMPROVEMENTS
- PROPOSED ROW
- EXISTING NEIGHBORHOOD WALLS
- VALIDATION LOCATIONS
- AMBIENT MEASUREMENT SITES

NOISE IMPACTS AND RECEIVERS

US 380
SEGMENT D



FIGURE D-5
NOV 2022



Legend

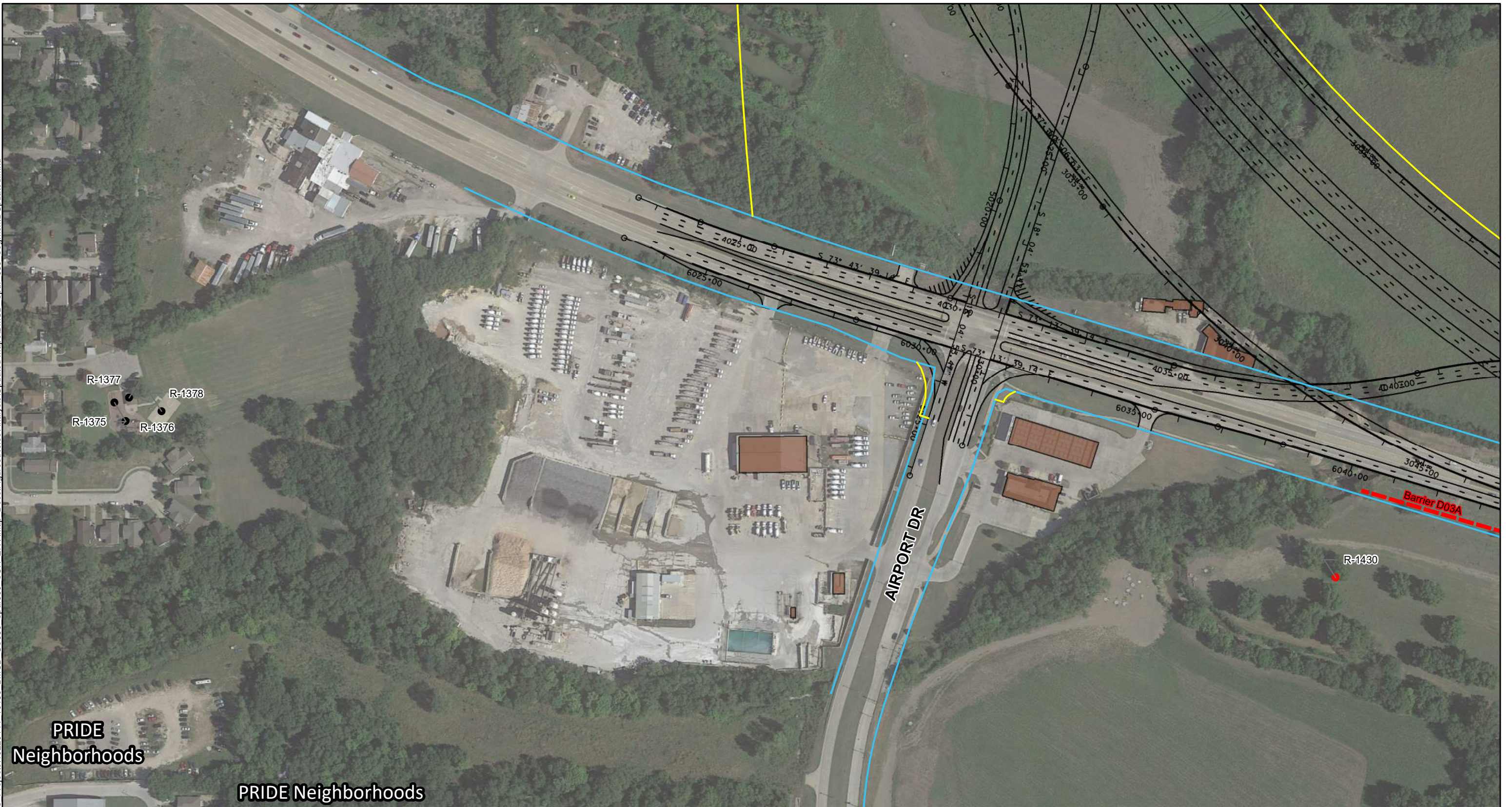
- BARRIER ANALYZED BUT NOT PROPOSED
- IMPACTED RECEIVER
- NON-IMPACTED RECEIVER
- RESIDENTIAL DISPLACEMENT
- COMMERCIAL DISPLACEMENT
- EXISTING ROW
- PROPOSED IMPROVEMENTS
- PROPOSED ROW
- EXISTING NEIGHBORHOOD WALLS
- VALIDATION LOCATIONS
- AMBIENT MEASUREMENT SITES

NOISE IMPACTS AND RECEIVERS

US 380
SEGMENT D

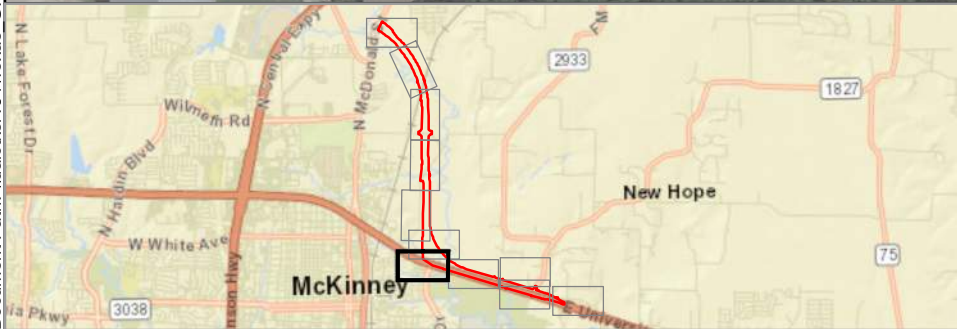


FIGURE D-6
NOV 2022



PRIDE
Neighborhoods

PRIDE Neighborhoods



Legend

- BARRIER ANALYZED BUT NOT PROPOSED
- IMPACTED RECEIVER
- NON-IMPACTED RECEIVER
- RESIDENTIAL DISPLACEMENT
- COMMERCIAL DISPLACEMENT
- EXISTING ROW
- PROPOSED IMPROVEMENTS
- PROPOSED ROW
- EXISTING NEIGHBORHOOD WALLS
- VALIDATION LOCATIONS
- AMBIENT MEASUREMENT SITES

NOISE IMPACTS AND RECEIVERS

US 380
SEGMENT D

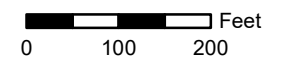
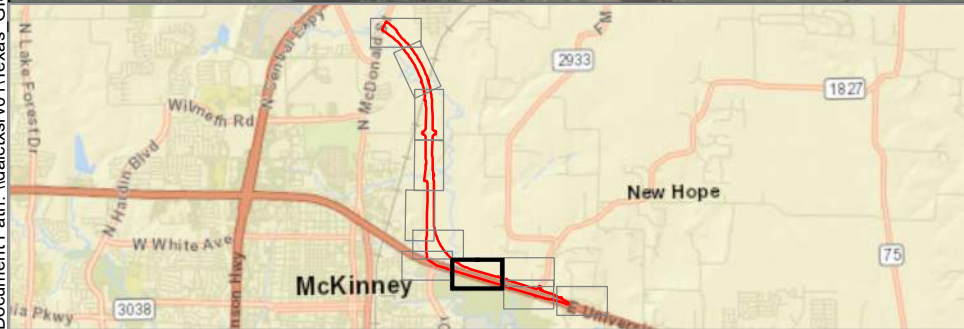
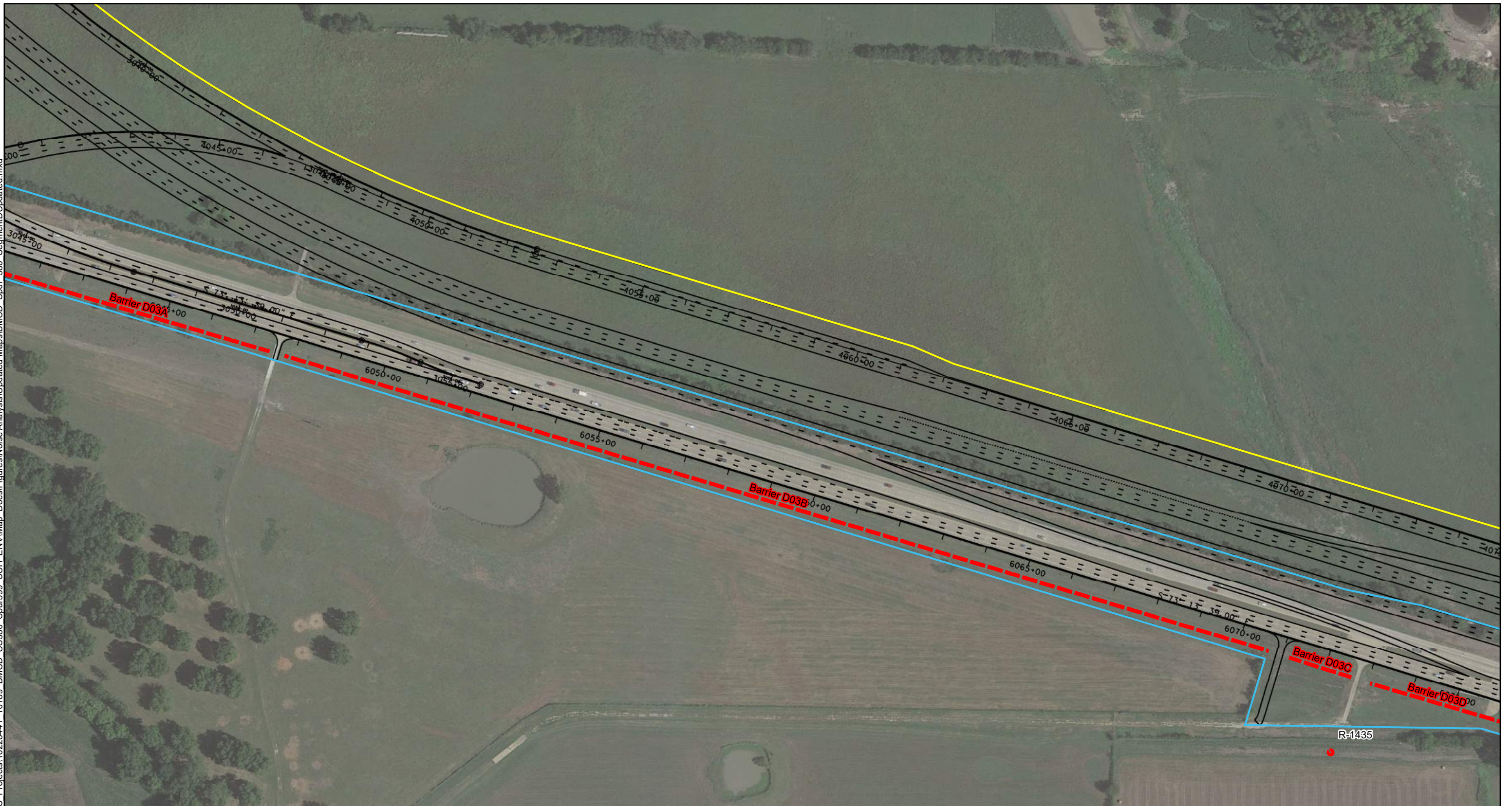


FIGURE D-7
NOV 2022



Legend

- BARRIER ANALYZED BUT NOT PROPOSED
- IMPACTED RECEIVER
- NON-IMPACTED RECEIVER
- RESIDENTIAL DISPLACEMENT
- COMMERCIAL DISPLACEMENT
- EXISTING ROW
- PROPOSED IMPROVEMENTS
- PROPOSED ROW
- EXISTING NEIGHBORHOOD WALLS
- VALIDATION LOCATIONS
- AMBIENT MEASUREMENT SITES

NOISE IMPACTS AND RECEIVERS

US 380
SEGMENT D

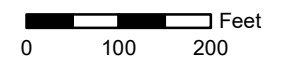
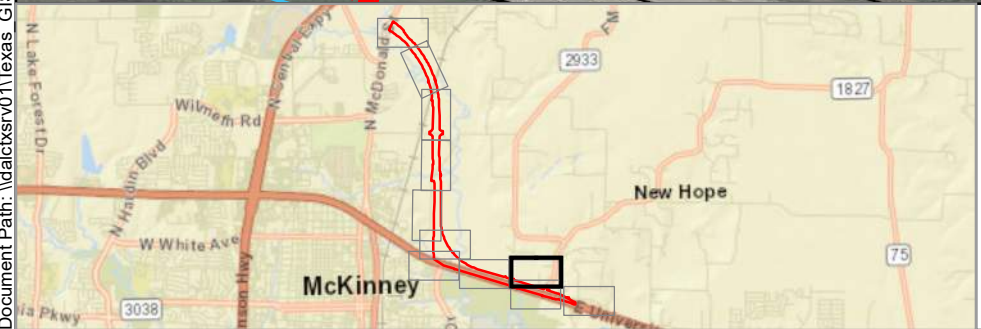
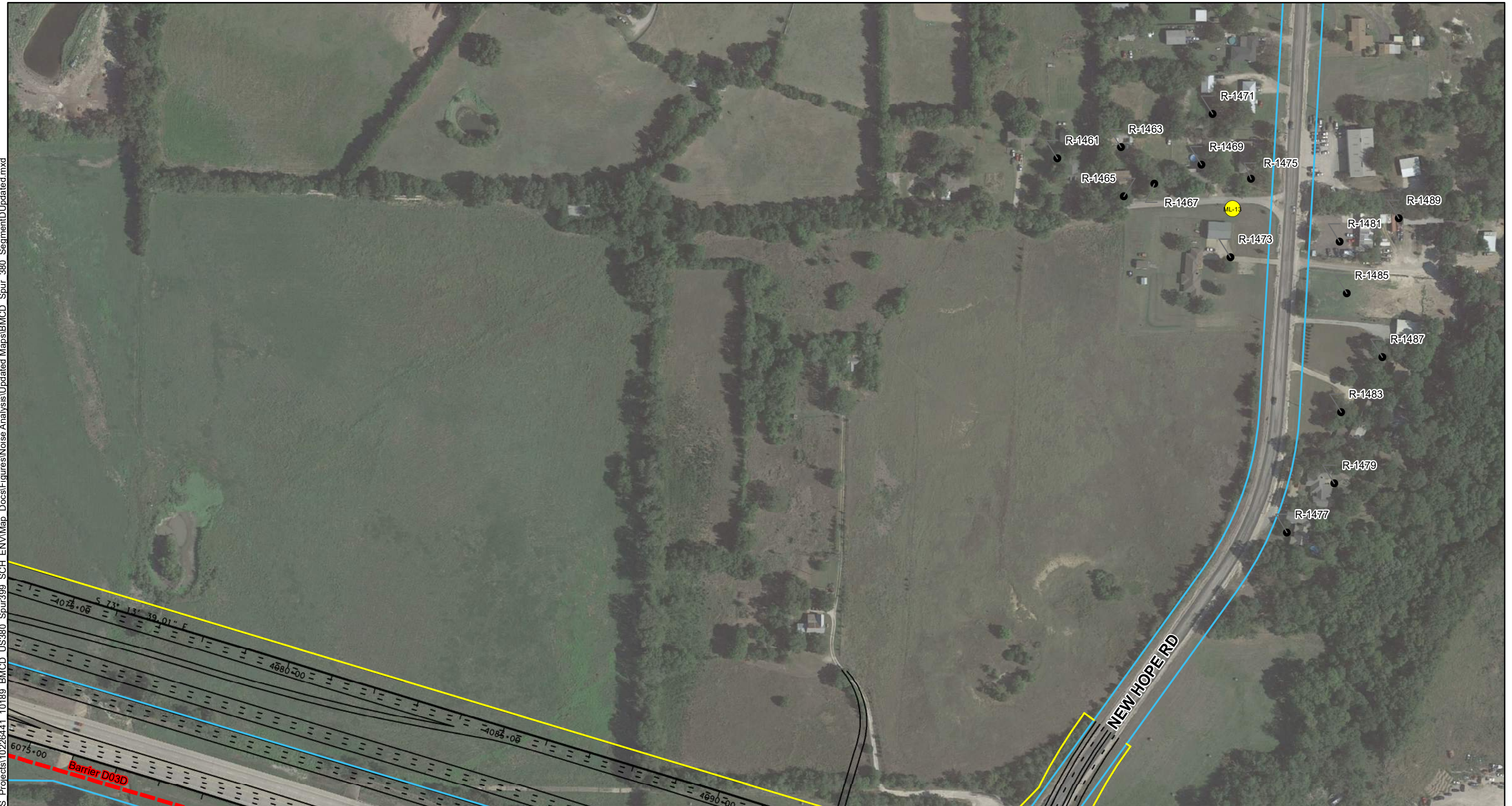


FIGURE D-8
NOV 2022



Legend

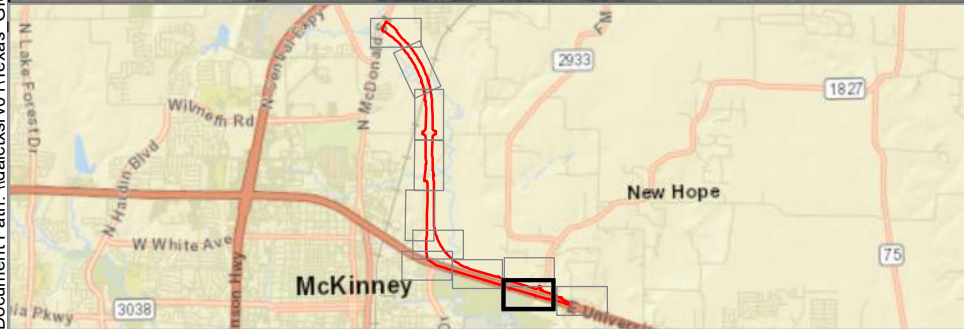
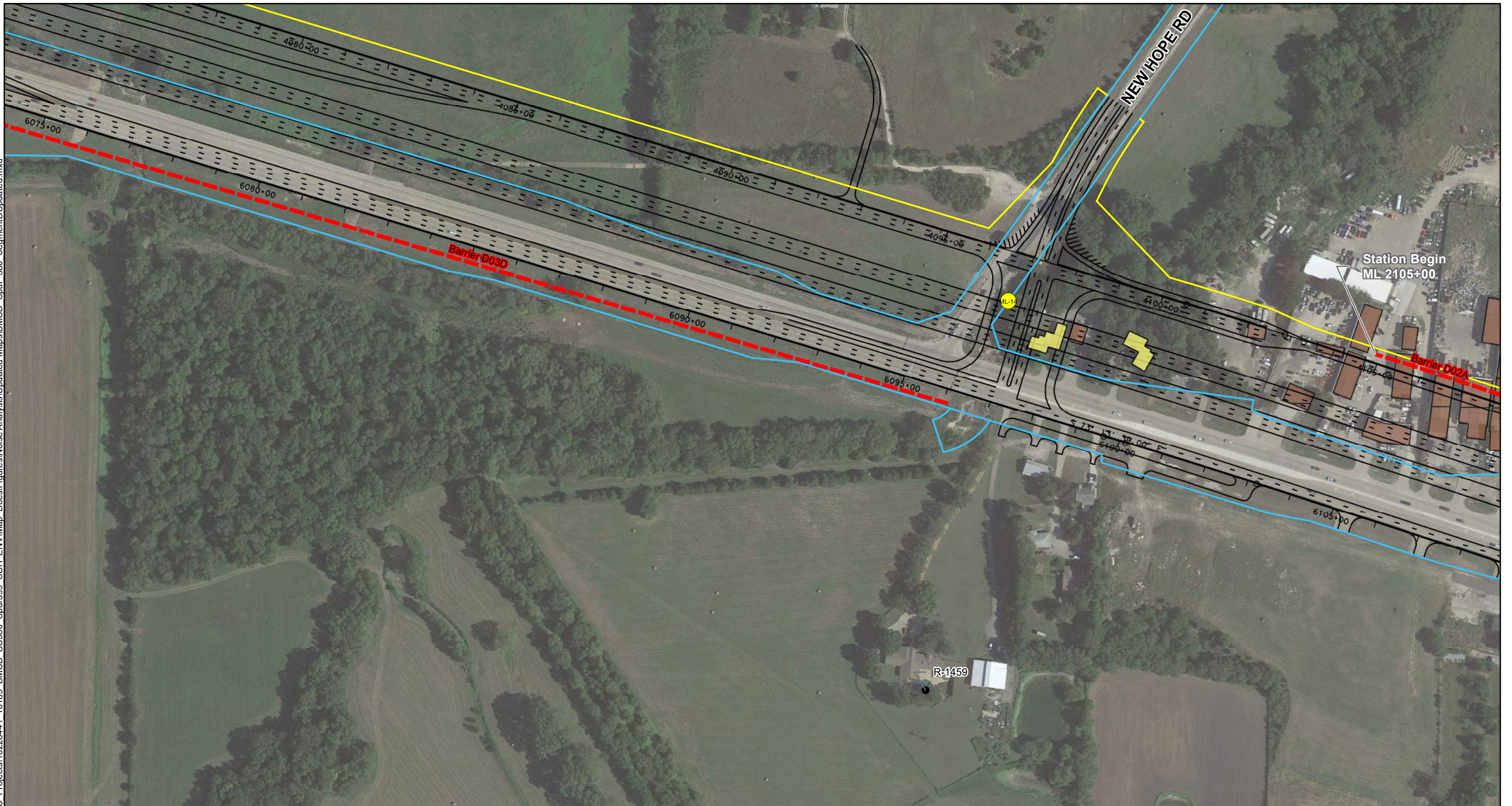
- BARRIER ANALYZED BUT NOT PROPOSED
- IMPACTED RECEIVER
- NON-IMPACTED RECEIVER
- RESIDENTIAL DISPLACEMENT
- COMMERCIAL DISPLACEMENT
- EXISTING ROW
- PROPOSED IMPROVEMENTS
- PROPOSED ROW
- EXISTING NEIGHBORHOOD WALLS
- VALIDATION LOCATIONS
- AMBIENT MEASUREMENT SITES

NOISE IMPACTS AND RECEIVERS

US 380
SEGMENT D



FIGURE D-9
NOV 2022



Legend

- BARRIER ANALYZED BUT NOT PROPOSED
- IMPACTED RECEIVER
- NON-IMPACTED RECEIVER
- RESIDENTIAL DISPLACEMENT
- COMMERCIAL DISPLACEMENT
- EXISTING ROW
- PROPOSED IMPROVEMENTS
- PROPOSED ROW
- EXISTING NEIGHBORHOOD WALLS
- VALIDATION LOCATIONS
- AMBIENT MEASUREMENT SITES

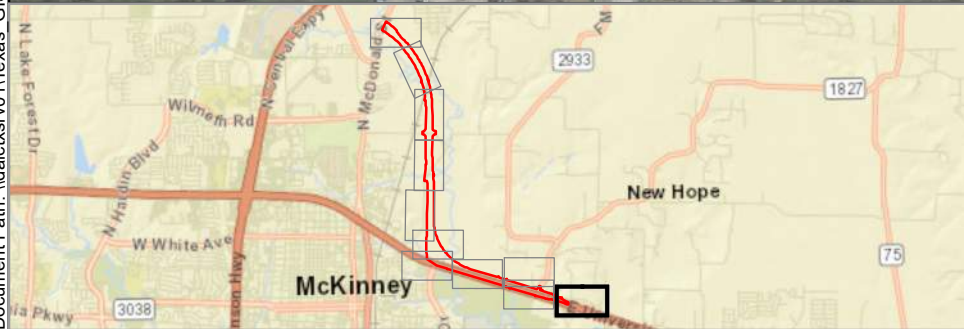
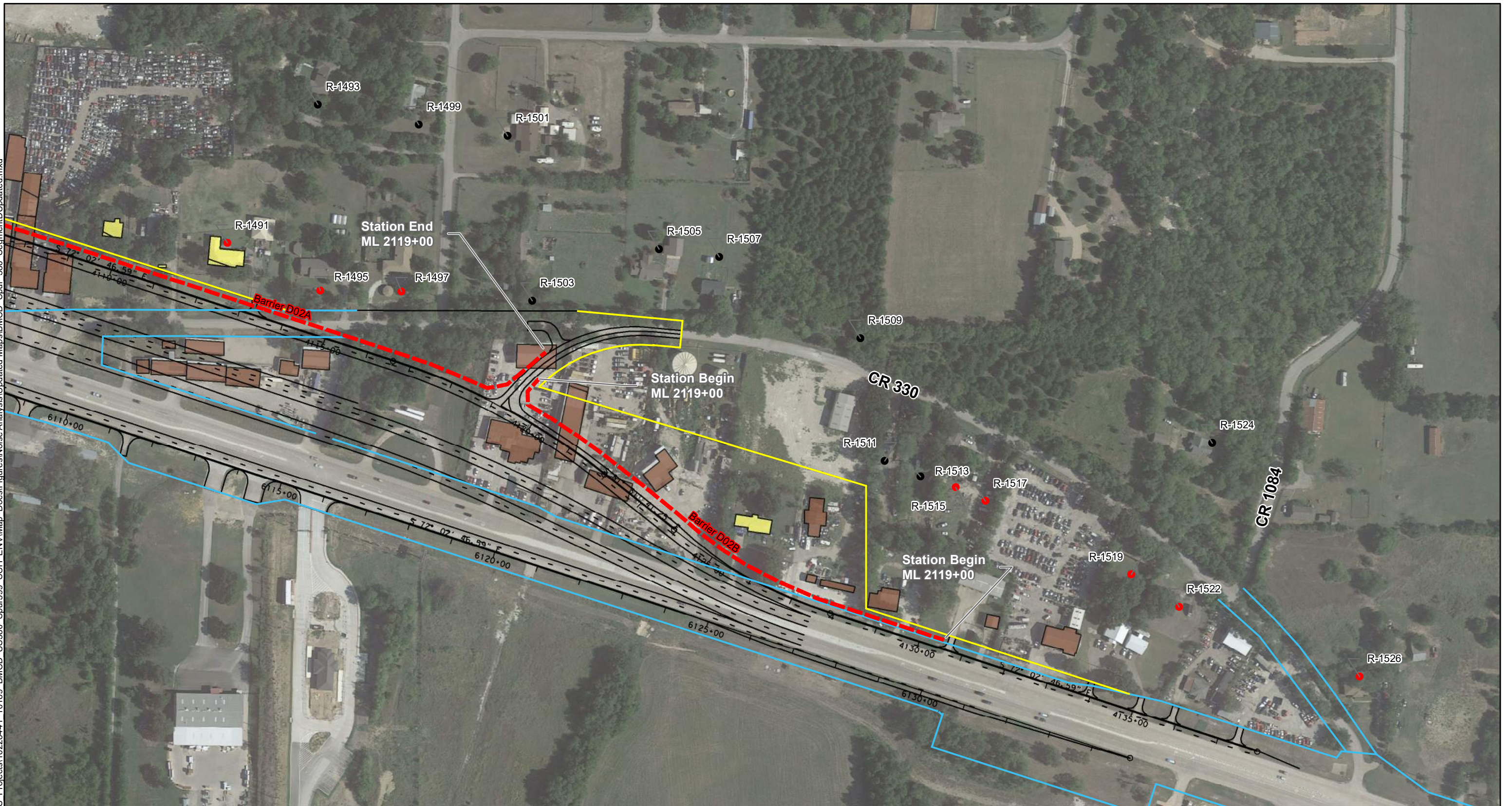
NOISE IMPACTS AND RECEIVERS

US 380
SEGMENT D



FIGURE D-10
NOV 2022

Document Path: \\dalctsr\01\Texas GIS Projects\10226441_10189_BMCD_US380_Spur399_SCH_ENV\Map Docs\Figures\Noise Analysis\Updated Maps\BMCD_Spur_380_SegmentD\Updated.mxd



Legend

- BARRIER ANALYZED BUT NOT PROPOSED
- IMPACTED RECEIVER
- NON-IMPACTED RECEIVER
- RESIDENTIAL DISPLACEMENT
- COMMERCIAL DISPLACEMENT
- EXISTING ROW
- PROPOSED IMPROVEMENTS
- PROPOSED ROW
- EXISTING NEIGHBORHOOD WALLS
- VALIDATION LOCATIONS
- AMBIENT MEASUREMENT SITES

NOISE IMPACTS AND RECEIVERS

US 380
SEGMENT D

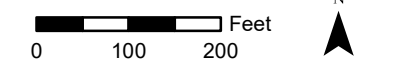
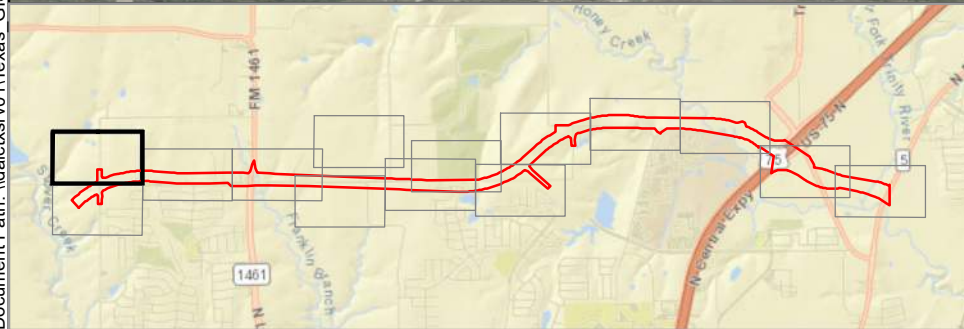


FIGURE D-11
NOV 2022

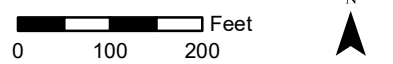


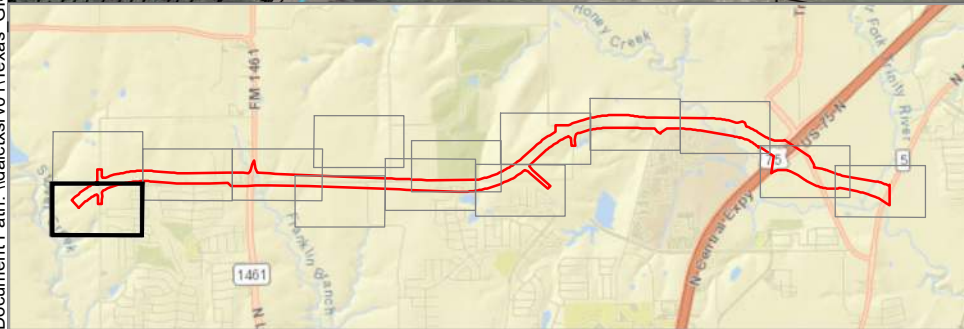
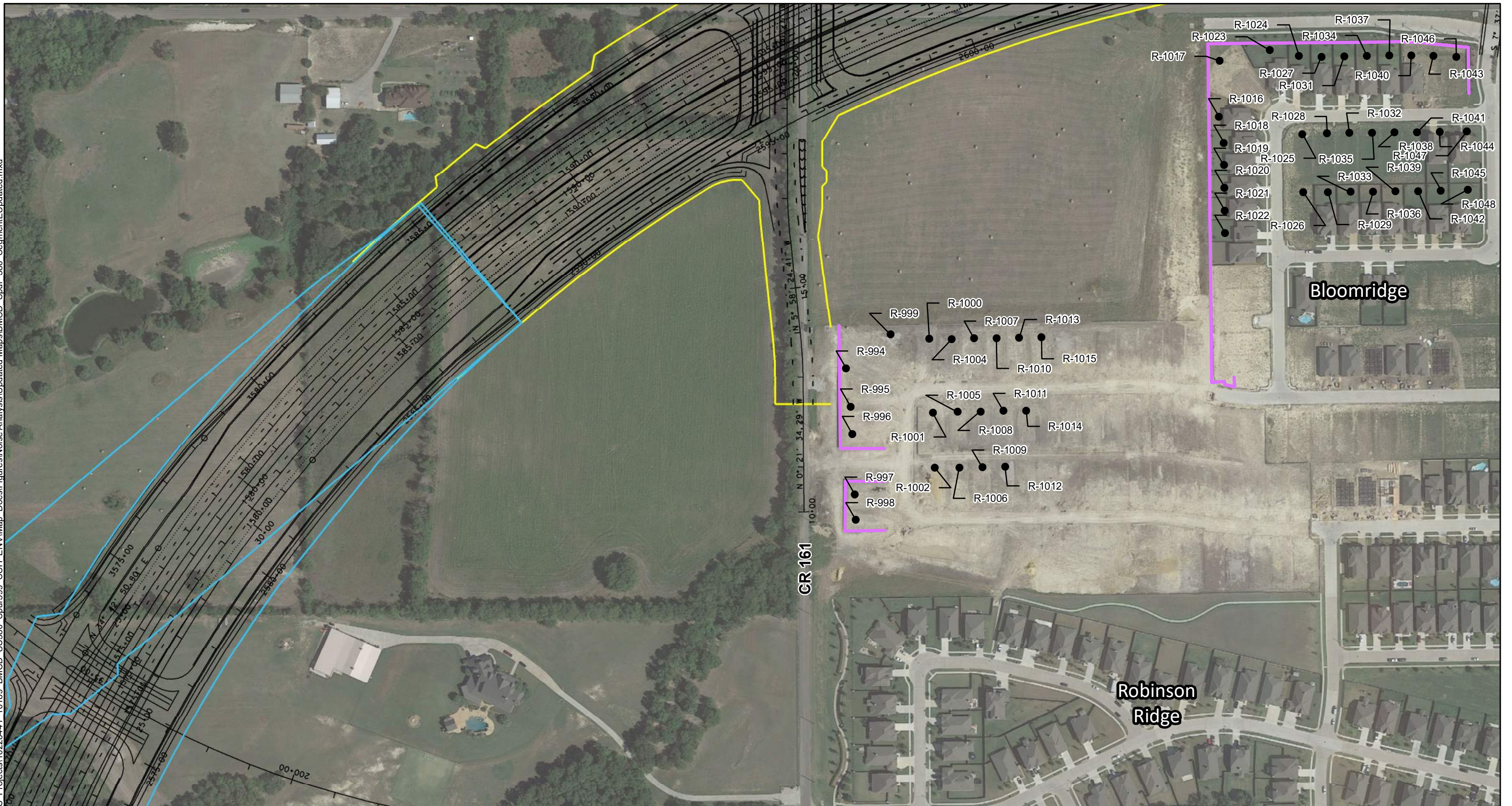
Legend

- PROPOSED BARRIER
- BARRIER ANALYZED BUT NOT PROPOSED
- IMPACTED RECEIVER
- NON-IMPACTED RECEIVER
- BENEFITED RECEIVER
- RESIDENTIAL DISPLACEMENT
- COMMERCIAL DISPLACEMENT
- EXISTING ROW
- PROPOSED IMPROVEMENTS
- PROPOSED ROW
- EXISTING NEIGHBORHOOD WALLS
- VALIDATION LOCATIONS
- AMBIENT MEASUREMENT SITES

NOISE IMPACTS AND RECEIVERS

US 380
SEGMENT E





Legend

- PROPOSED BARRIER
- BARRIER ANALYZED BUT NOT PROPOSED
- IMPACTED RECEIVER
- NON-IMPACTED RECEIVER
- BENEFITED RECEIVER
- RESIDENTIAL DISPLACEMENT
- COMMERCIAL DISPLACEMENT
- EXISTING ROW
- PROPOSED IMPROVEMENTS
- PROPOSED ROW
- EXISTING NEIGHBORHOOD WALLS
- VALIDATION LOCATIONS
- AMBIENT MEASUREMENT SITES

NOISE IMPACTS AND RECEIVERS

US 380
SEGMENT E

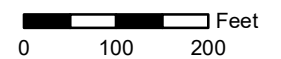
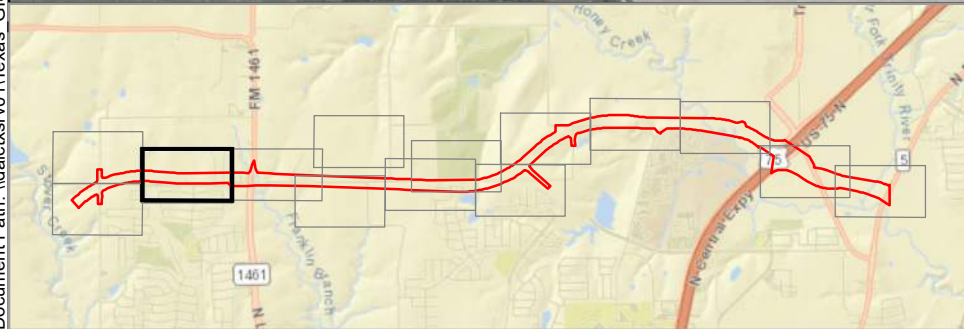
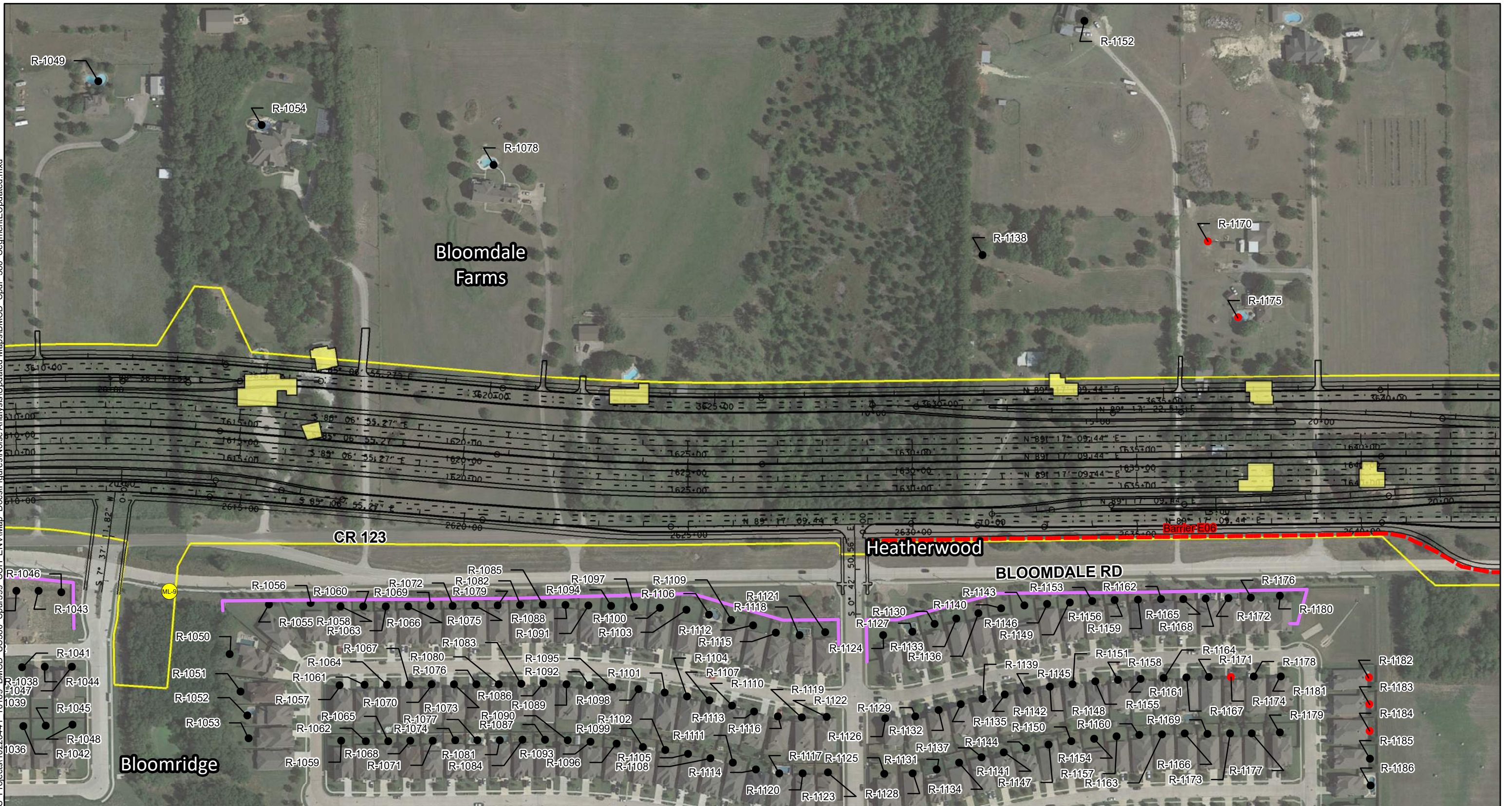


FIGURE E-2
NOV 2022

Document Path: \\dalctsr\01\Texas GIS Projects\10226441_10189_BMCD_US380_Spur399_SCH_ENV\Map_Docs\Figures\Noise Analysis\Updated Maps\BMCD_Spur_380_SegmentEUpdated.mxd



Legend

- PROPOSED BARRIER
- BARRIER ANALYZED BUT NOT PROPOSED
- IMPACTED RECEIVER
- NON-IMPACTED RECEIVER
- BENEFITED RECEIVER
- RESIDENTIAL DISPLACEMENT
- COMMERCIAL DISPLACEMENT
- EXISTING ROW
- PROPOSED IMPROVEMENTS
- PROPOSED ROW
- EXISTING NEIGHBORHOOD WALLS
- VALIDATION LOCATIONS
- AMBIENT MEASUREMENT SITES

NOISE IMPACTS AND RECEIVERS

US 380
SEGMENT E

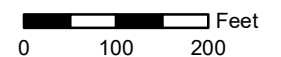
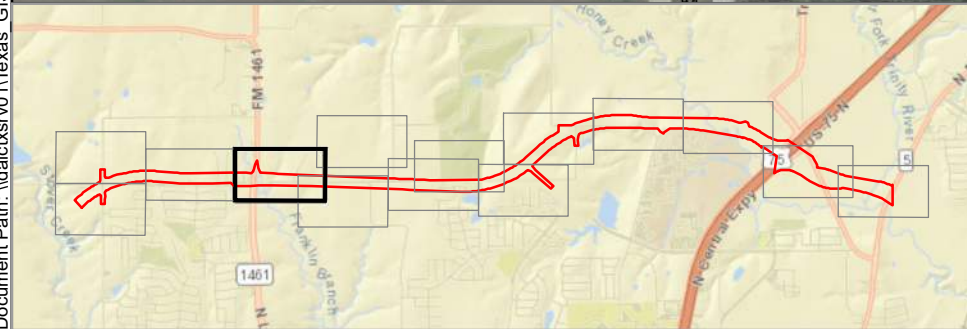
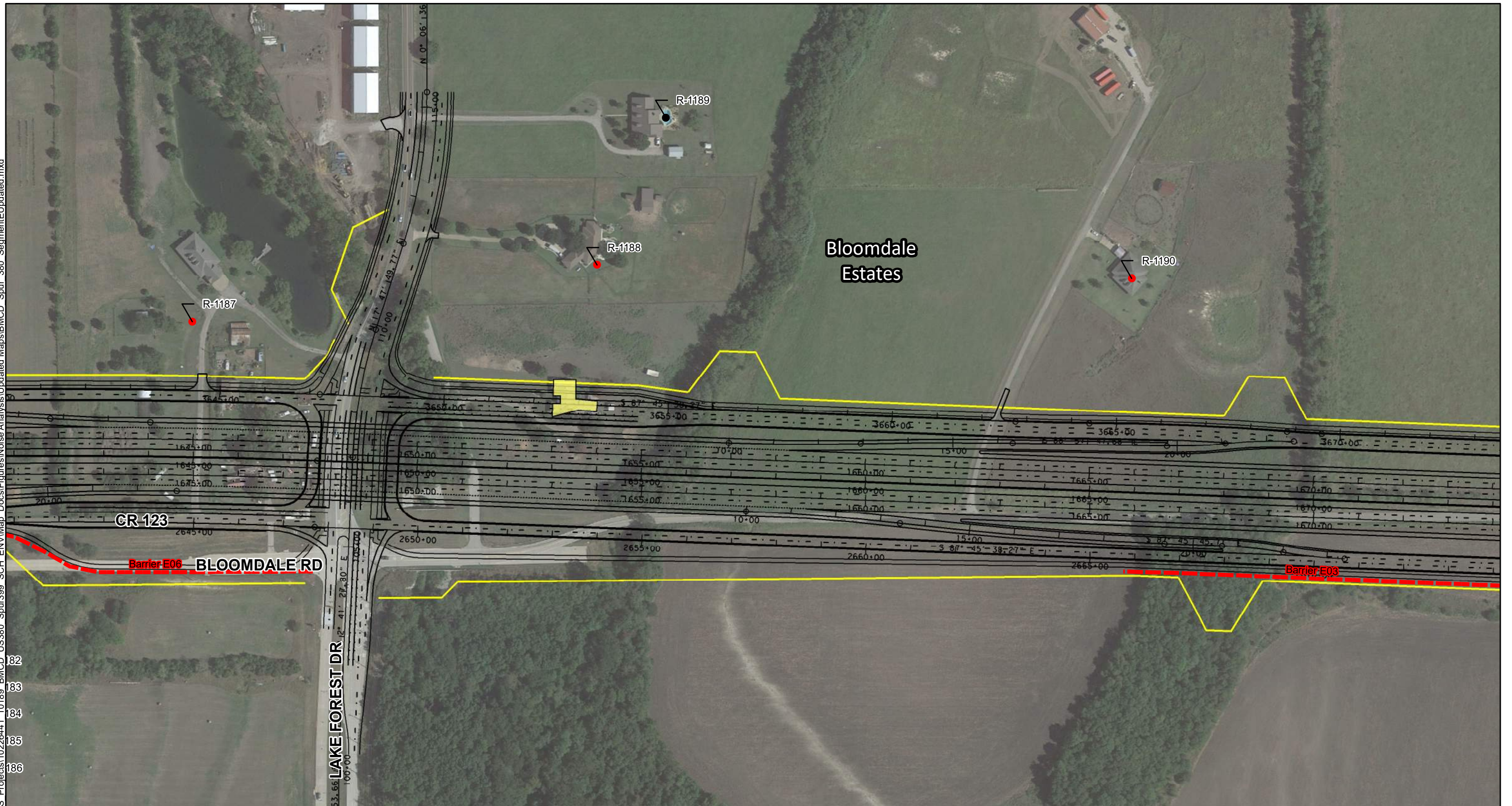


FIGURE E-3
NOV 2022



Legend

- PROPOSED BARRIER
- - - BARRIER ANALYZED BUT NOT PROPOSED
- IMPACTED RECEIVER
- NON-IMPACTED RECEIVER
- BENEFITED RECEIVER
- RESIDENTIAL DISPLACEMENT
- COMMERCIAL DISPLACEMENT
- EXISTING ROW
- PROPOSED IMPROVEMENTS
- PROPOSED ROW
- EXISTING NEIGHBORHOOD WALLS
- VALIDATION LOCATIONS
- AMBIENT MEASUREMENT SITES

NOISE IMPACTS AND RECEIVERS

US 380
SEGMENT E

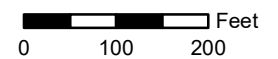
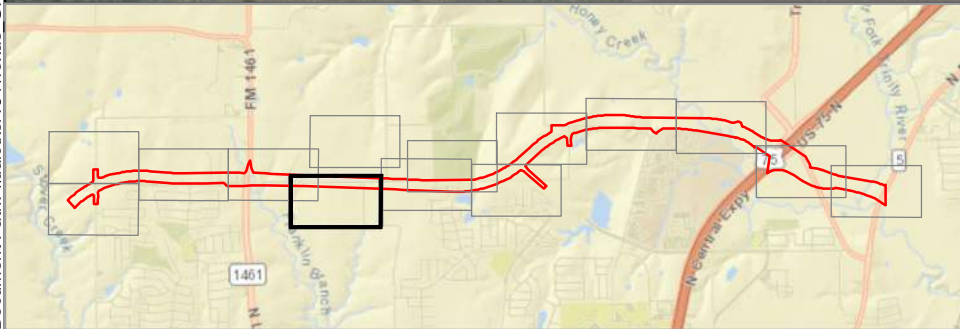


FIGURE E-4
NOV 2022

Document Path: \\dalactxrv01\Texas GIS Projects\10226441_10189_BMCD_US380_Spur399_SCH_ENV\Map_Docs\Figures\Noise Analysis\Updated Maps\BMCD_Spur_380_SegmentEUpdated.mxd



Legend

- PROPOSED BARRIER
- - - BARRIER ANALYZED BUT NOT PROPOSED
- IMPACTED RECEIVER
- NON-IMPACTED RECEIVER
- BENEFITED RECEIVER
- RESIDENTIAL DISPLACEMENT
- COMMERCIAL DISPLACEMENT
- EXISTING ROW
- PROPOSED IMPROVEMENTS
- PROPOSED ROW
- EXISTING NEIGHBORHOOD WALLS
- VALIDATION LOCATIONS
- AMBIENT MEASUREMENT SITES

NOISE IMPACTS AND RECEIVERS

US 380
SEGMENT E

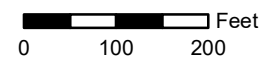
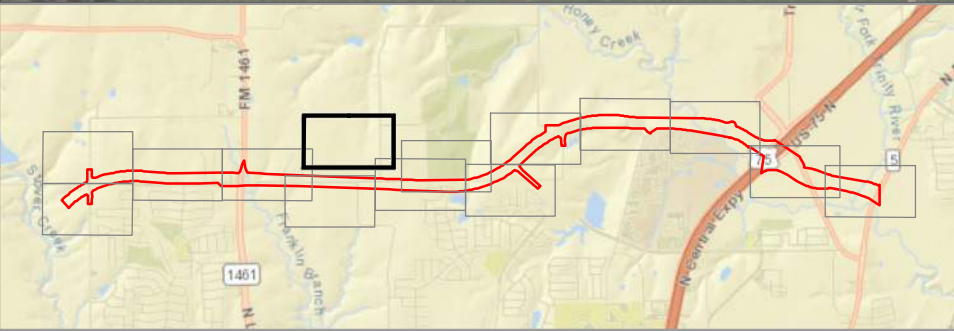


FIGURE E-5
NOV 2022



Bloomdale Estates



Legend

- PROPOSED BARRIER
- - - BARRIER ANALYZED BUT NOT PROPOSED
- IMPACTED RECEIVER
- NON-IMPACTED RECEIVER
- BENEFITED RECEIVER
- RESIDENTIAL DISPLACEMENT
- COMMERCIAL DISPLACEMENT
- EXISTING ROW
- PROPOSED IMPROVEMENTS
- PROPOSED ROW
- EXISTING NEIGHBORHOOD WALLS
- VALIDATION LOCATIONS
- AMBIENT MEASUREMENT SITES

NOISE IMPACTS AND RECEIVERS

US 380
SEGMENT E

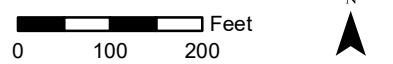
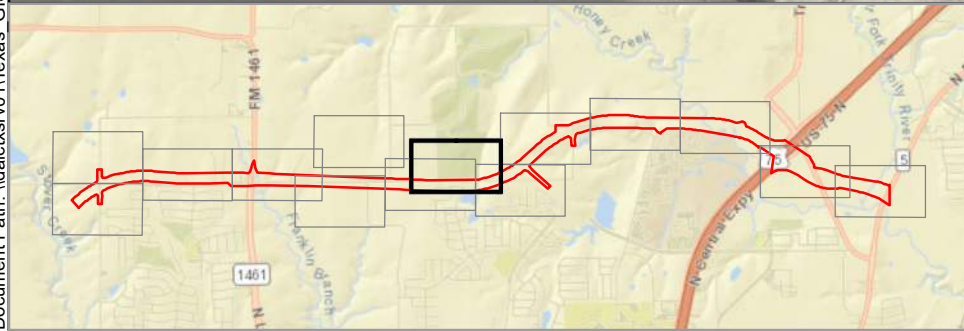
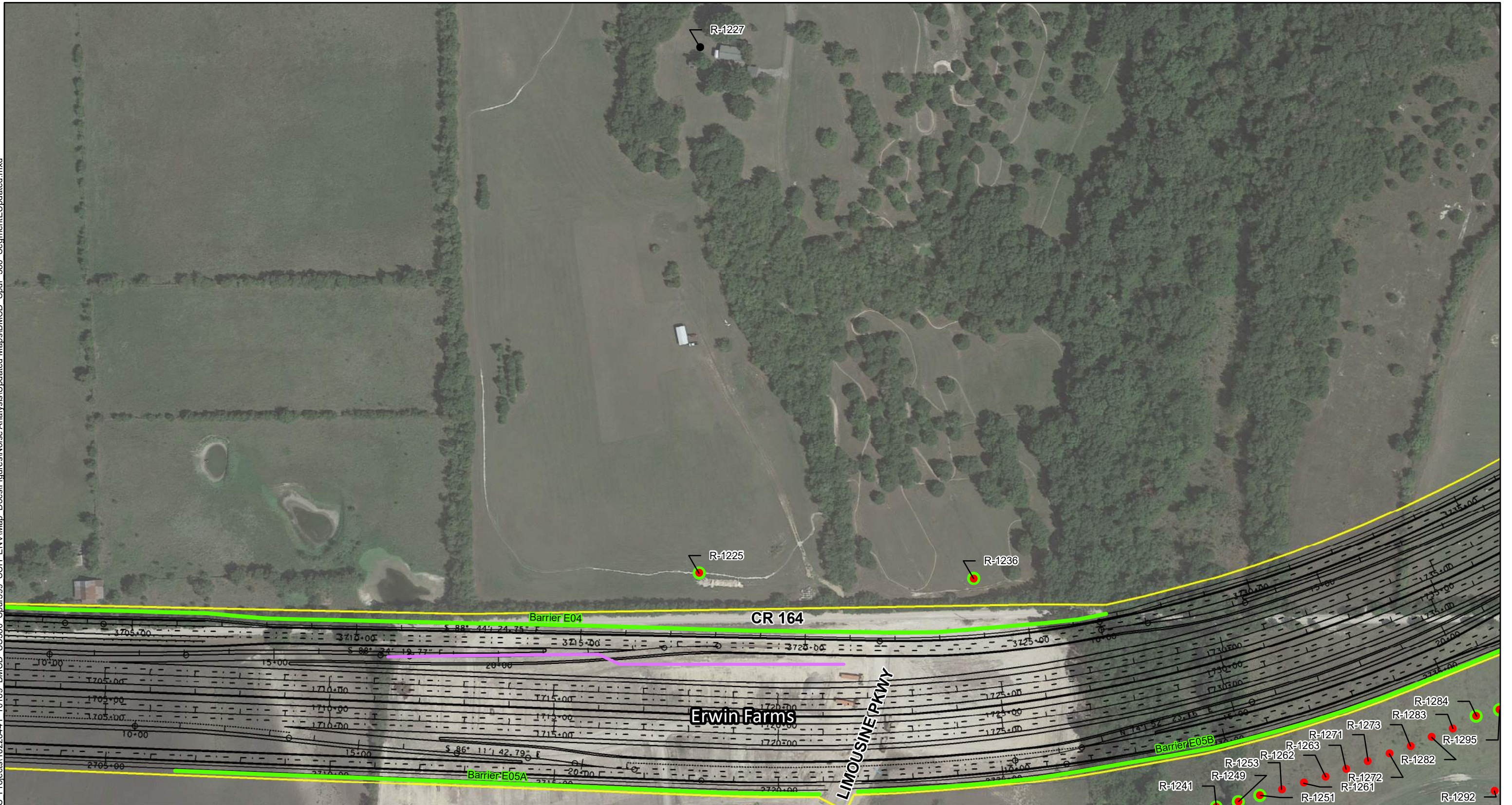


FIGURE E-6
NOV 2022



Legend

- PROPOSED BARRIER
- - - BARRIER ANALYZED BUT NOT PROPOSED
- IMPACTED RECEIVER
- NON-IMPACTED RECEIVER
- BENEFITED RECEIVER
- RESIDENTIAL DISPLACEMENT
- COMMERCIAL DISPLACEMENT
- EXISTING ROW
- PROPOSED IMPROVEMENTS
- PROPOSED ROW
- EXISTING NEIGHBORHOOD WALLS
- VALIDATION LOCATIONS
- AMBIENT MEASUREMENT SITES

NOISE IMPACTS AND RECEIVERS

US 380
SEGMENT E

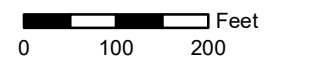
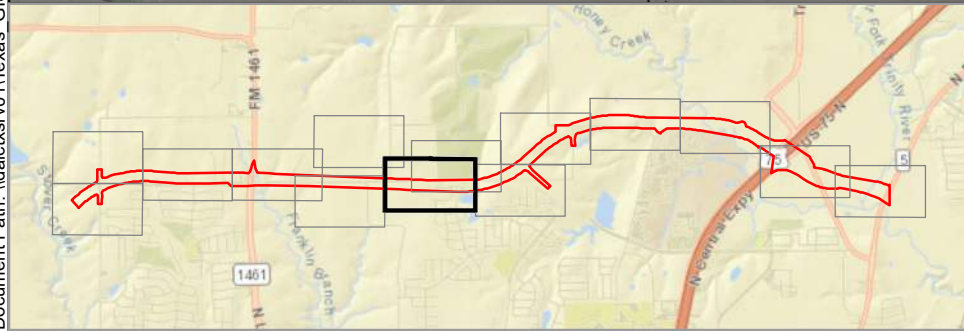


FIGURE E-7
NOV 2022



Legend

- PROPOSED BARRIER
- - - BARRIER ANALYZED BUT NOT PROPOSED
- IMPACTED RECEIVER
- NON-IMPACTED RECEIVER
- BENEFITED RECEIVER
- RESIDENTIAL DISPLACEMENT
- COMMERCIAL DISPLACEMENT
- EXISTING ROW
- PROPOSED IMPROVEMENTS
- PROPOSED ROW
- EXISTING NEIGHBORHOOD WALLS
- VALIDATION LOCATIONS
- AMBIENT MEASUREMENT SITES

NOISE IMPACTS AND RECEIVERS

US 380
SEGMENT E

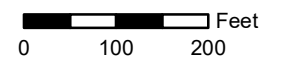
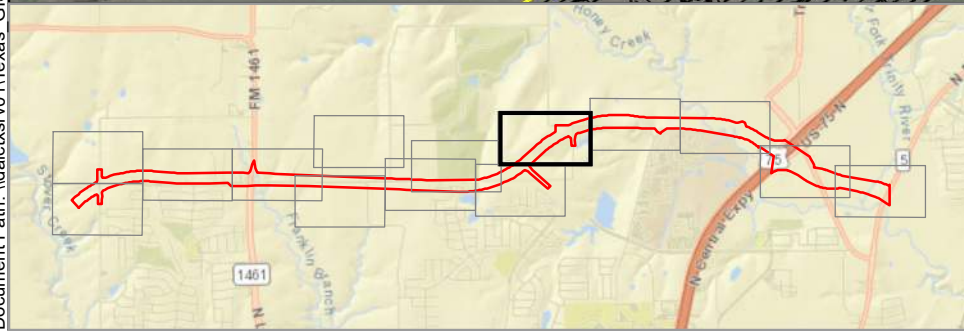
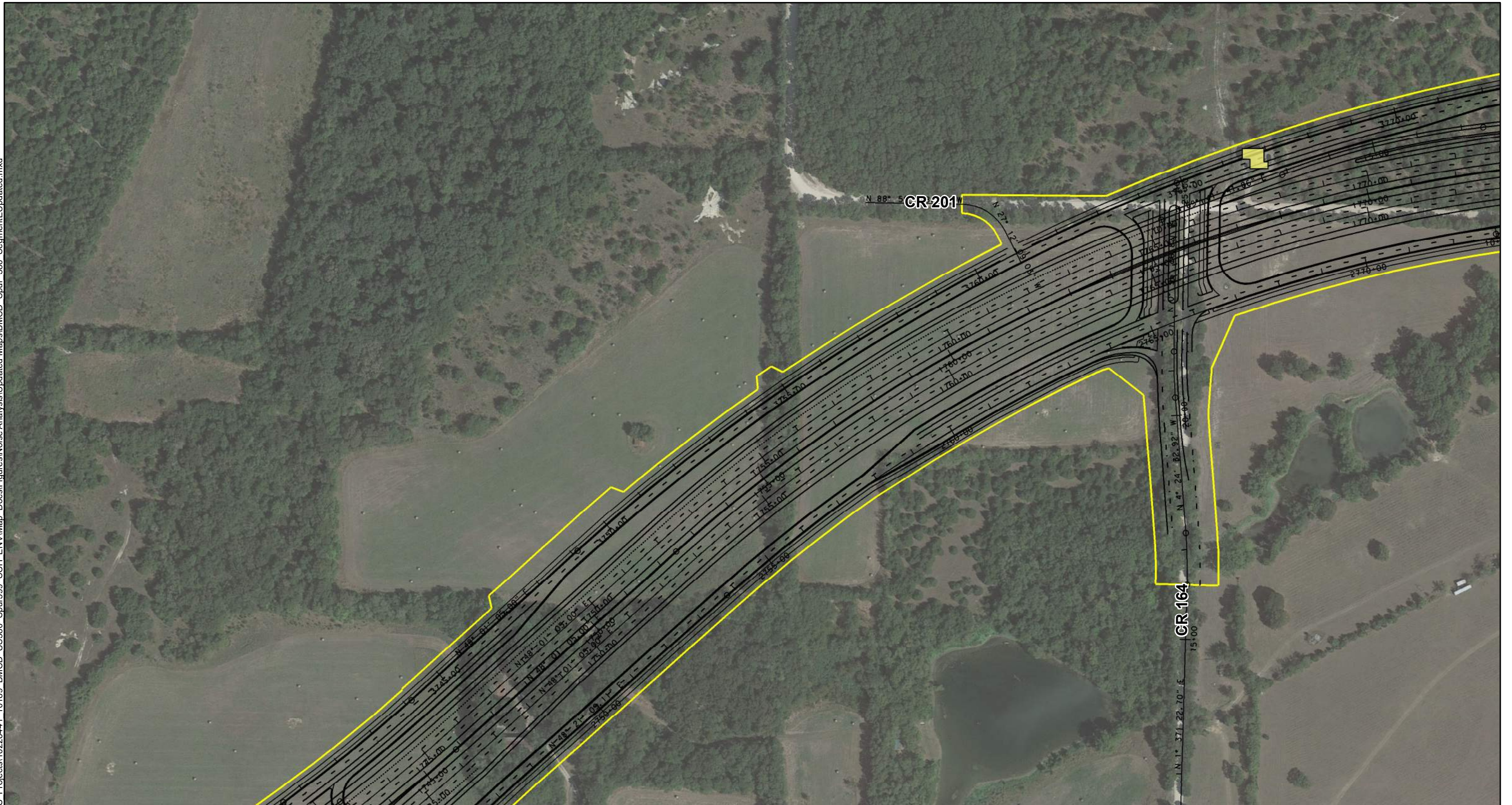


FIGURE E-8
NOV 2022



Legend

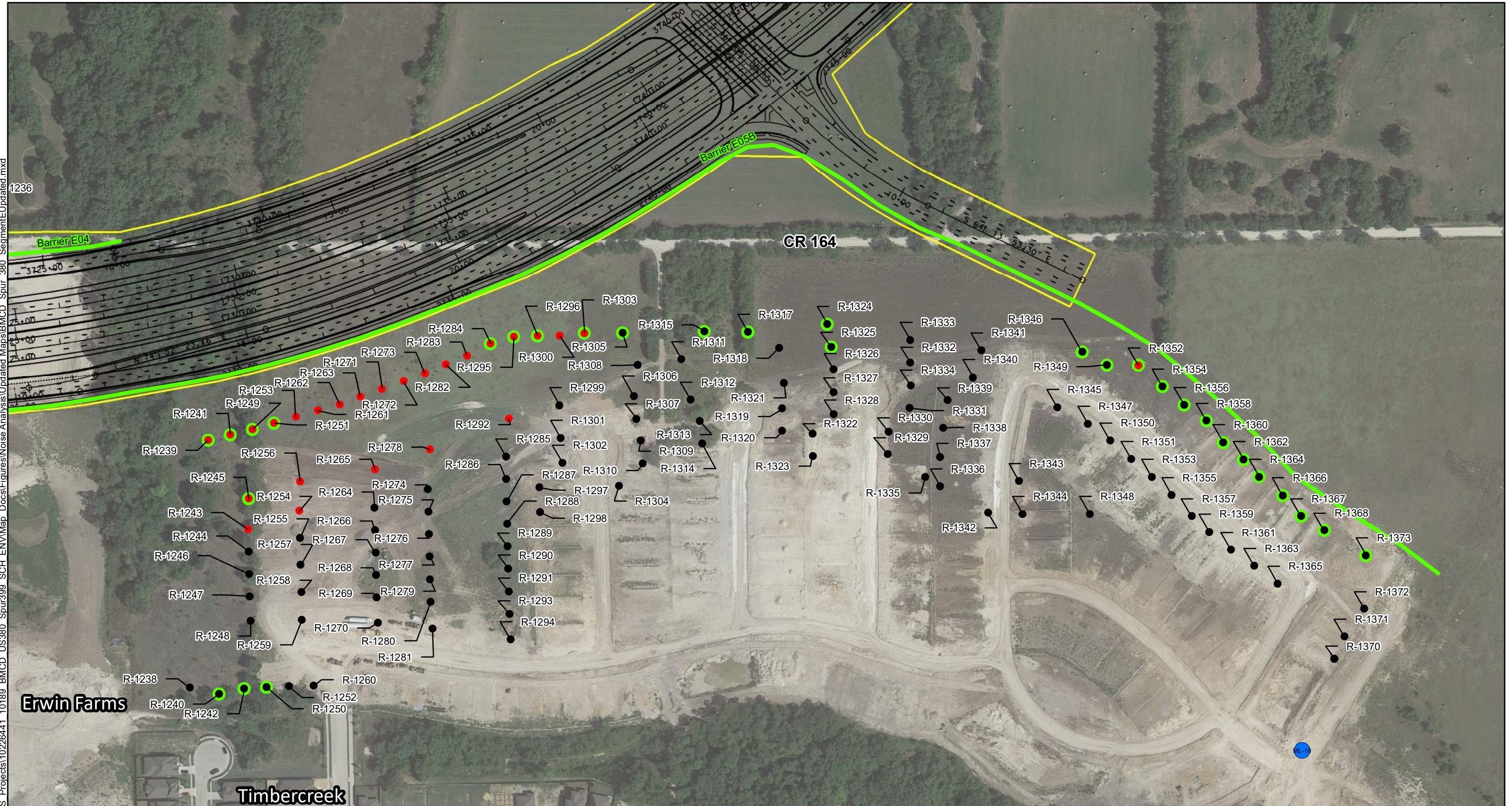
- PROPOSED BARRIER
- BARRIER ANALYZED BUT NOT PROPOSED
- IMPACTED RECEIVER
- NON-IMPACTED RECEIVER
- BENEFITED RECEIVER
- RESIDENTIAL DISPLACEMENT
- COMMERCIAL DISPLACEMENT
- EXISTING ROW
- PROPOSED IMPROVEMENTS
- PROPOSED ROW
- EXISTING NEIGHBORHOOD WALLS
- VALIDATION LOCATIONS
- AMBIENT MEASUREMENT SITES

NOISE IMPACTS AND RECEIVERS

US 380
SEGMENT E

0 100 200 Feet

FIGURE E-9
NOV 2022



Erwin Farms

Timbercreek

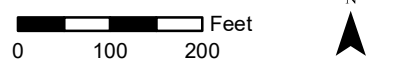
CR 164

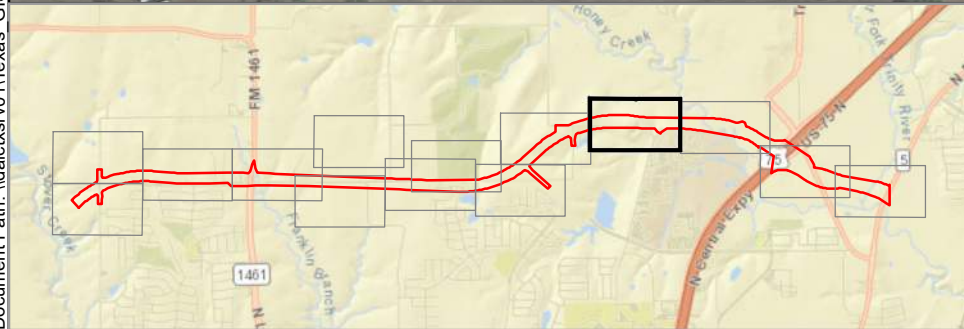
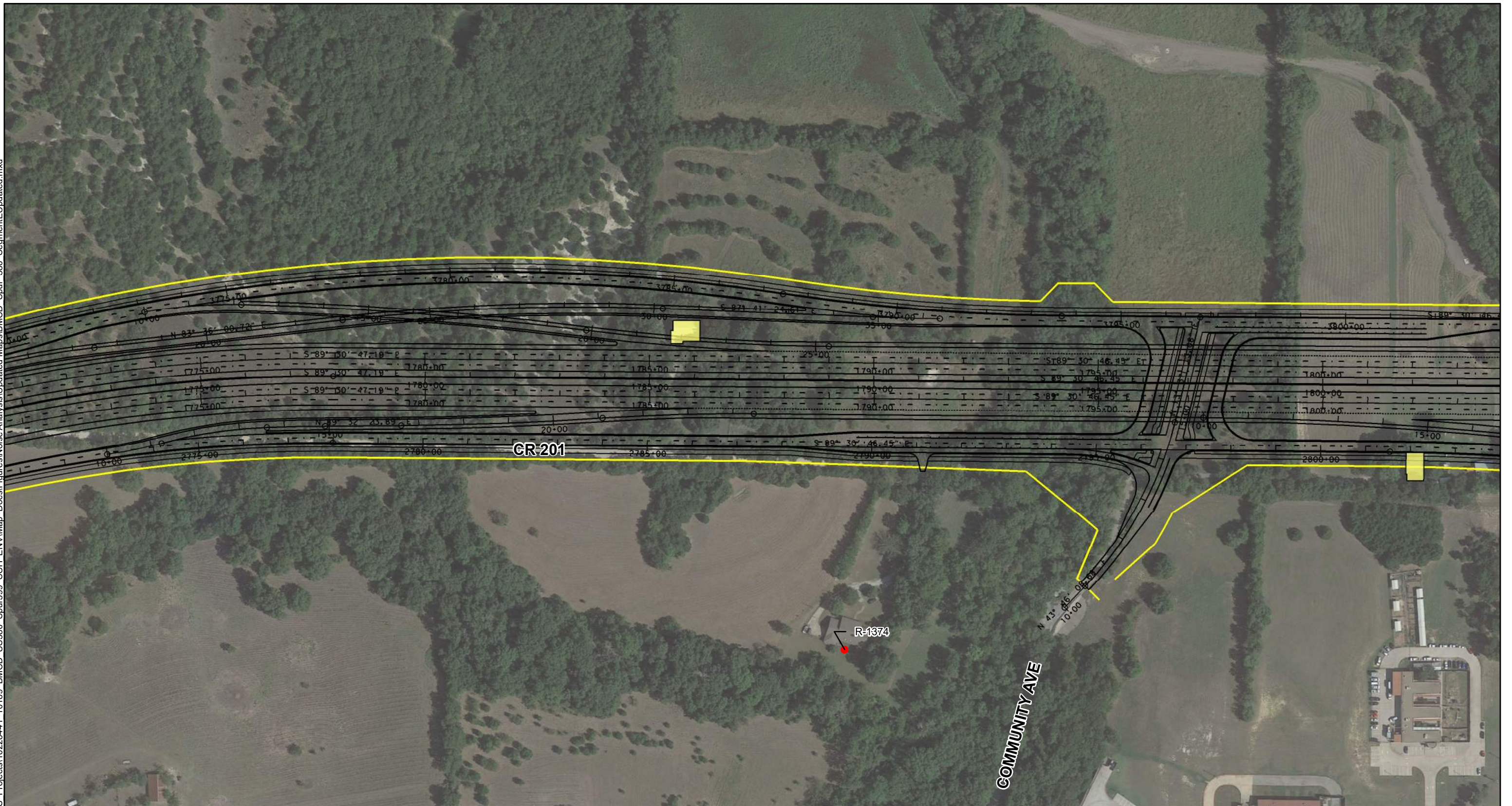
Legend

- PROPOSED BARRIER
- - - BARRIER ANALYZED BUT NOT PROPOSED
- IMPACTED RECEIVER
- NON-IMPACTED RECEIVER
- BENEFITED RECEIVER
- RESIDENTIAL DISPLACEMENT
- COMMERCIAL DISPLACEMENT
- EXISTING ROW
- PROPOSED IMPROVEMENTS
- PROPOSED ROW
- EXISTING NEIGHBORHOOD WALLS
- VALIDATION LOCATIONS
- AMBIENT MEASUREMENT SITES

NOISE IMPACTS AND RECEIVERS

US 380
SEGMENT E



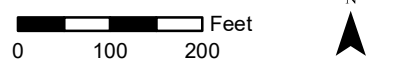


Legend

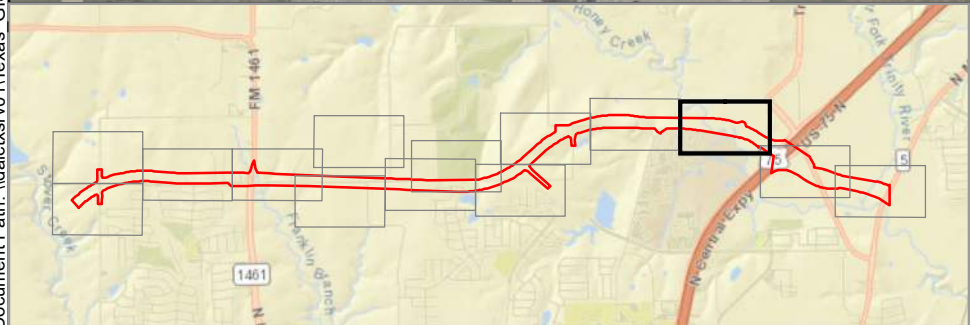
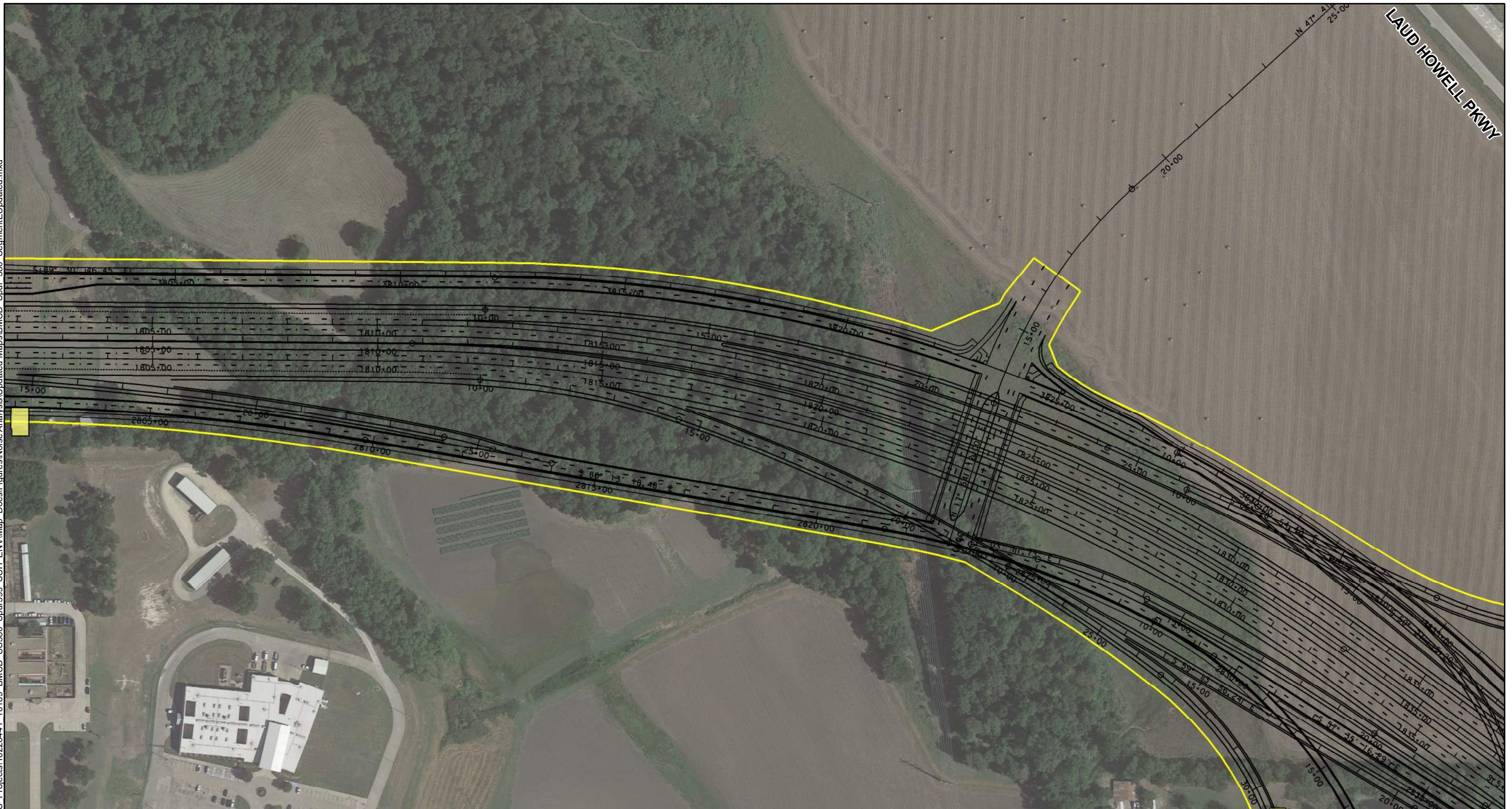
- PROPOSED BARRIER
- BARRIER ANALYZED BUT NOT PROPOSED
- IMPACTED RECEIVER
- NON-IMPACTED RECEIVER
- BENEFITED RECEIVER
- RESIDENTIAL DISPLACEMENT
- COMMERCIAL DISPLACEMENT
- EXISTING ROW
- PROPOSED IMPROVEMENTS
- PROPOSED ROW
- EXISTING NEIGHBORHOOD WALLS
- VALIDATION LOCATIONS
- AMBIENT MEASUREMENT SITES

NOISE IMPACTS AND RECEIVERS

US 380
SEGMENT E



Document Path: \\dalctsr01\Texas GIS Projects\10226441_10189_BMCD_US380_Spur399_SCH_ENVM\Map_Docs\Figures\NoiseAnalysis\Updated Maps\BMCD_Spur_380_SegmentEUpdated.mxd



Legend

- PROPOSED BARRIER
- - - BARRIER ANALYZED BUT NOT PROPOSED
- IMPACTED RECEIVER
- NON-IMPACTED RECEIVER
- BENEFITED RECEIVER
- RESIDENTIAL DISPLACEMENT
- COMMERCIAL DISPLACEMENT
- EXISTING ROW
- - - PROPOSED IMPROVEMENTS
- PROPOSED ROW
- - - EXISTING NEIGHBORHOOD WALLS
- VALIDATION LOCATIONS
- AMBIENT MEASUREMENT SITES

NOISE IMPACTS AND RECEIVERS

US 380
SEGMENT E

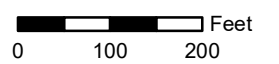
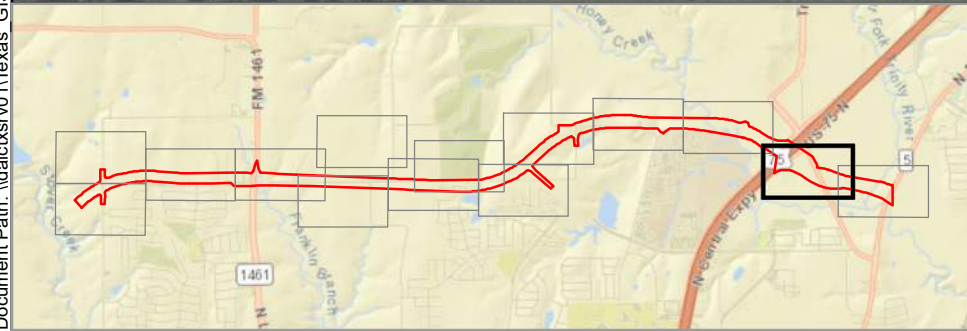
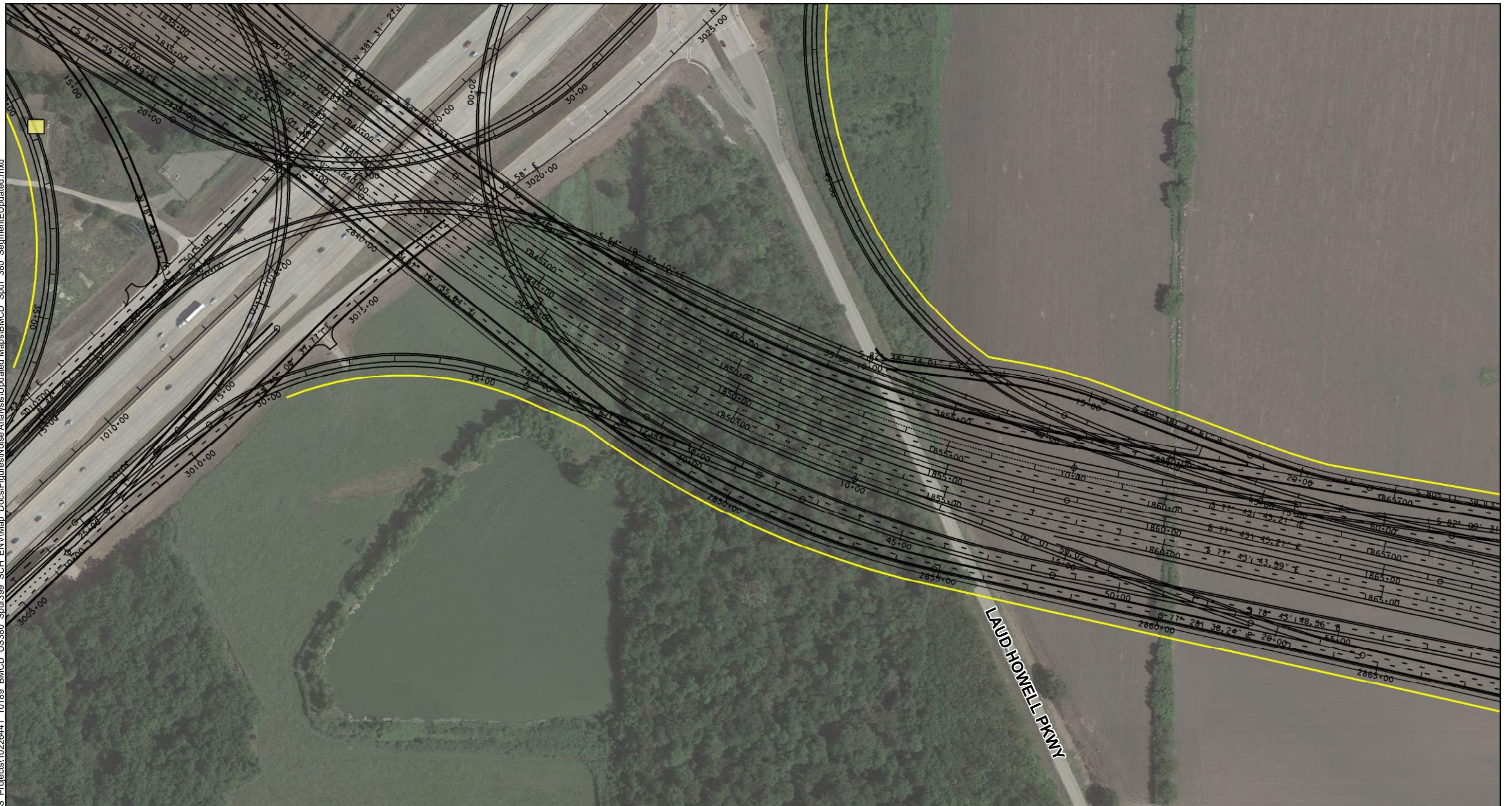


FIGURE E-12
NOV 2022



Legend

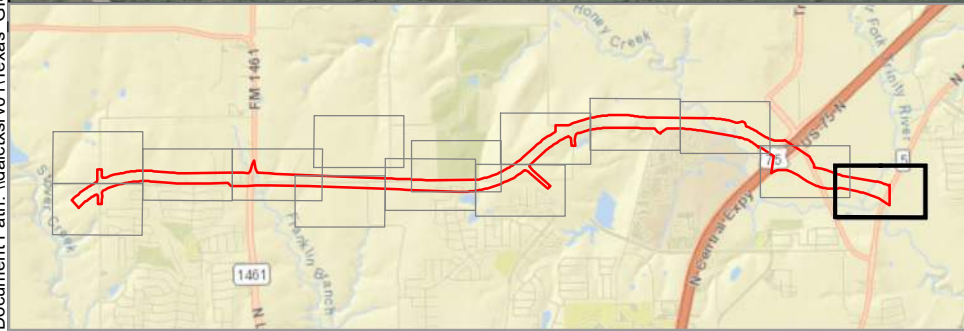
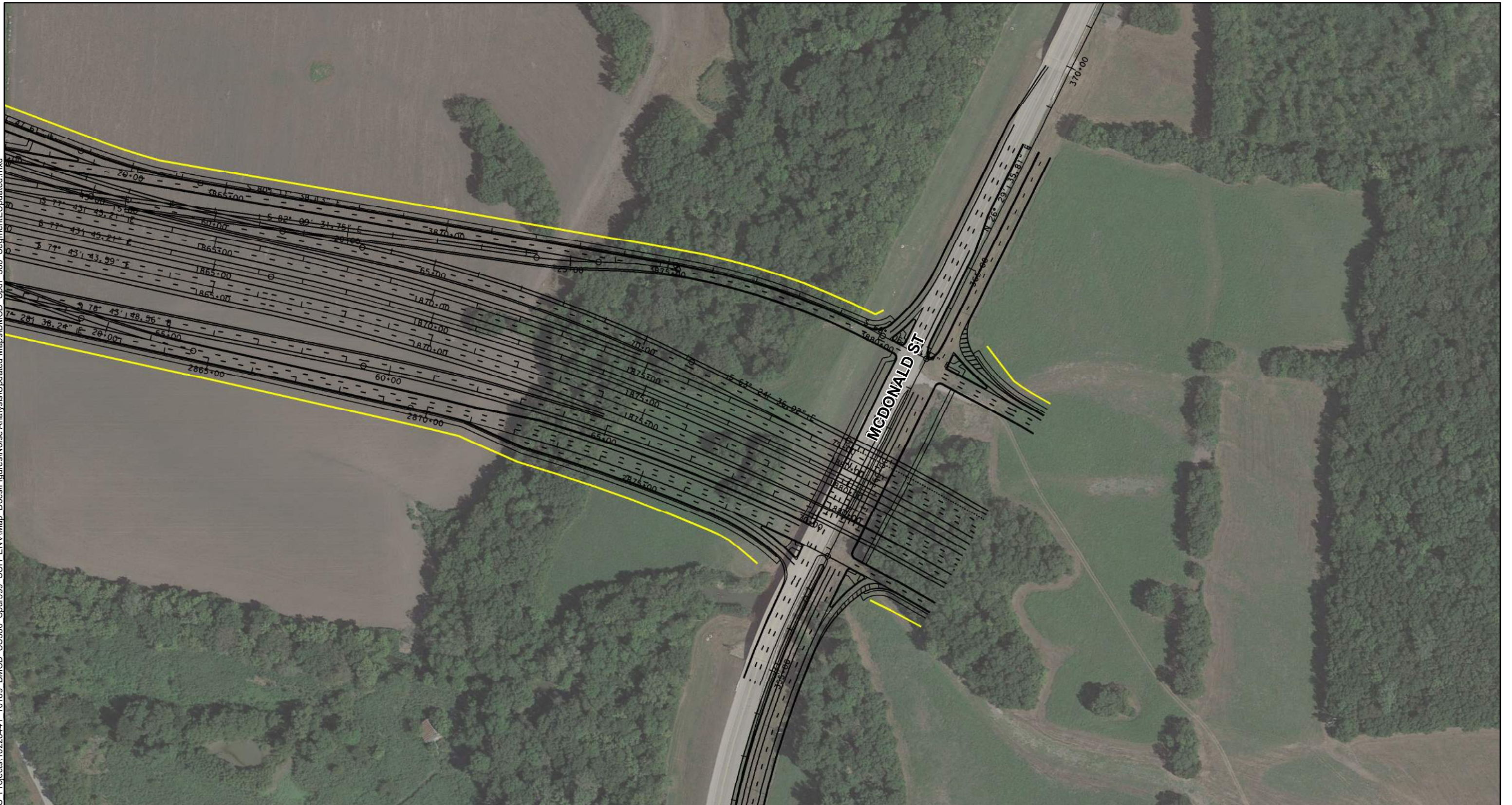
- PROPOSED BARRIER
- - - BARRIER ANALYZED BUT NOT PROPOSED
- IMPACTED RECEIVER
- NON-IMPACTED RECEIVER
- BENEFITED RECEIVER
- RESIDENTIAL DISPLACEMENT
- COMMERCIAL DISPLACEMENT
- EXISTING ROW
- PROPOSED IMPROVEMENTS
- PROPOSED ROW
- EXISTING NEIGHBORHOOD WALLS
- VALIDATION LOCATIONS
- AMBIENT MEASUREMENT SITES

NOISE IMPACTS AND RECEIVERS

US 380
SEGMENT E



FIGURE E-13
NOV 2022



Legend

- PROPOSED BARRIER
- BARRIER ANALYZED BUT NOT PROPOSED
- IMPACTED RECEIVER
- NON-IMPACTED RECEIVER
- BENEFITED RECEIVER
- RESIDENTIAL DISPLACEMENT
- COMMERCIAL DISPLACEMENT
- EXISTING ROW
- PROPOSED IMPROVEMENTS
- PROPOSED ROW
- EXISTING NEIGHBORHOOD WALLS
- VALIDATION LOCATIONS
- AMBIENT MEASUREMENT SITES

NOISE IMPACTS AND RECEIVERS

US 380
SEGMENT E

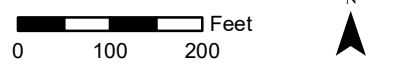


FIGURE E-14
NOV 2022

Attachment B – Traffic Figures

TRAFFIC ANALYSIS FOR HIGHWAY DESIGN (Option C)

Dallas District

February 15, 2022

										Total Number of Equivalent 18k Single Axle Load Applications One Direction Expected for a 20 Year Period (2030 to 2050)			
Description of Location	Average Daily Traffic		Dir Dist %	K Factor	Percent Trucks		ATHWLD	Percent Tandem Axles in ATHWLD	Flexible Pavement	S N	Rigid Pavement	SLAB	
	2030	2050			ADT	DHV							
	Base Year				Base Year								
Data for Use in Air & Noise Analysis													
Vehicle Class	Base Year												
	% of ADT	% of DHV											
Light Duty	95.1	97.1											
Medium Duty	1.8	1.1											
Heavy Duty	3.1	1.8											
										Total Number of Equivalent 18k Single Axle Load Applications One Direction Expected for a 30 Year Period (2030 to 2060)			
Description of Location	Average Daily Traffic		Dir Dist %	K Factor	Percent Trucks		ATHWLD	Percent Tandem Axles in ATHWLD	Flexible Pavement	S N	Rigid Pavement	SLAB	
	2030	2060			ADT	DHV							
	Base Year				Base Year								
<u>US 380 Proposed Mainlanes</u> From Coit Road to FM 1827 Segment A - Section #1 From Coit Road To Exit to Coit Road Collin County													
93,000	162,500	58 - 42	8.5	4.9	2.9	12,600	30	28,689,000	3	38,627,500	8"		

NOT INTENDED FOR CONSTRUCTION
 BIDDING OR PERMIT PURPOSES
 Dan Perge, P.E.
 Serial Number 77159

TRAFFIC ANALYSIS FOR HIGHWAY DESIGN (Option C)

Dallas District

February 15, 2022

										Total Number of Equivalent 18k Single Axle Load Applications One Direction Expected for a 20 Year Period (2030 to 2050)													
Description of Location	Average Daily Traffic		Dir Dist %	K Factor	Base Year Percent Trucks		ATHWLD	Percent Tandem Axles in ATHWLD	Flexible Pavement	S N	Rigid Pavement	SLAB											
	2030	2050			ADT	DHV																	
<u>US 380 Proposed Mainlanes</u> From Coit Road to FM 1827 Segment A - Section #2 From Exit to Coit Road To Future Bloomdale Road Collin County												75,400	115,900	58 - 42	8.5	5.2	3.1	12,400	40	15,183,500	3	20,452,500	8"
Data for Use in Air & Noise Analysis																							
Vehicle Class	Base Year																						
	% of ADT		% of DHV																				
Light Duty	94.8		96.9																				
Medium Duty	1.9		1.1																				
Heavy Duty	3.3		2.0																				
										Total Number of Equivalent 18k Single Axle Load Applications One Direction Expected for a 30 Year Period (2030 to 2060)													
Description of Location	Average Daily Traffic		Dir Dist %	K Factor	Base Year Percent Trucks		ATHWLD	Percent Tandem Axles in ATHWLD	Flexible Pavement	S N	Rigid Pavement	SLAB											
	2030	2060			ADT	DHV																	
<u>US 380 Proposed Mainlanes</u> From Coit Road to FM 1827 Segment A - Section #2 From Exit to Coit Road To Future Bloomdale Road Collin County												75,400	131,700	58 - 42	8.5	5.2	3.1	12,500	40	24,656,500	3	33,213,000	8"

NOT INTENDED FOR CONSTRUCTION
 BIDDING OR PERMIT PURPOSES
 Dan Perge, P.E.
 Serial Number 77159

TRAFFIC ANALYSIS FOR HIGHWAY DESIGN (Option C)

Dallas District

February 15, 2022

									Total Number of Equivalent 18k Single Axle Load Applications One Direction Expected for a 20 Year Period (2030 to 2050)			
Description of Location	Average Daily Traffic		Dir Dist %	K Factor	Percent Trucks		ATHWLD	Percent Tandem Axles in ATHWLD	Flexible Pavement	S N	Rigid Pavement	SLAB
	2030	2050			ADT	DHV						
	Base Year				Base Year							
Data for Use in Air & Noise Analysis												
Vehicle Class	Base Year											
	% of ADT		% of DHV									
Light Duty	95.1		97.1									
Medium Duty	1.8		1.1									
Heavy Duty	3.1		1.8									
									Total Number of Equivalent 18k Single Axle Load Applications One Direction Expected for a 30 Year Period (2030 to 2060)			
Description of Location	Average Daily Traffic		Dir Dist %	K Factor	Percent Trucks		ATHWLD	Percent Tandem Axles in ATHWLD	Flexible Pavement	S N	Rigid Pavement	SLAB
	2030	2060			ADT	DHV						
	Base Year				Base Year							
<u>US 380 Proposed Mainlanes</u> From Coit Road to FM 1827 Segment B - Section #1 From Coit Road To Exit to Coit Road Collin County	93,000	162,500	58 - 42	8.5	4.9	2.9	12,600	30	28,689,000	3	38,627,500	8"

NOT INTENDED FOR CONSTRUCTION
 BIDDING OR PERMIT PURPOSES
 Dan Perge, P.E.
 Serial Number 77159

TRAFFIC ANALYSIS FOR HIGHWAY DESIGN (Option C)

Dallas District

February 15, 2022

										Total Number of Equivalent 18k Single Axle Load Applications One Direction Expected for a 20 Year Period (2030 to 2050)														
Description of Location	Average Daily Traffic		Dir Dist %	K Factor	Base Year Percent Trucks		ATHWLD	Percent Tandem Axles in ATHWLD	Flexible Pavement	S N	Rigid Pavement	SLAB												
	2030	2050			ADT	DHV																		
<u>US 380 Proposed Mainlanes</u> From Coit Road to FM 1827 Segment B - Section #2 From Exit to Coit Road To Future Bloomdale Road West Collin County													76,000	115,900	58 - 42	8.5	5.2	3.1	12,400	40	15,231,000	3	20,516,500	8"
Data for Use in Air & Noise Analysis																								
Vehicle Class	Base Year																							
	% of ADT		% of DHV																					
Light Duty	94.8		96.9																					
Medium Duty	1.9		1.1																					
Heavy Duty	3.3		2.0																					
										Total Number of Equivalent 18k Single Axle Load Applications One Direction Expected for a 30 Year Period (2030 to 2060)														
Description of Location	Average Daily Traffic		Dir Dist %	K Factor	Base Year Percent Trucks		ATHWLD	Percent Tandem Axles in ATHWLD	Flexible Pavement	S N	Rigid Pavement	SLAB												
	2030	2060			ADT	DHV																		
<u>US 380 Proposed Mainlanes</u> From Coit Road to FM 1827 Segment B - Section #2 From Exit to Coit Road To Future Bloomdale Road West Collin County													76,000	133,000	58 - 42	8.5	5.2	3.1	12,500	40	24,882,500	3	33,517,500	8"

NOT INTENDED FOR CONSTRUCTION
 BIDDING OR PERMIT PURPOSES
 Dan Perge, P.E.
 Serial Number 77159

TRAFFIC ANALYSIS FOR HIGHWAY DESIGN (Option C)

Dallas District

February 15, 2022

										Total Number of Equivalent 18k Single Axle Load Applications One Direction Expected for a 20 Year Period (2030 to 2050)											
Description of Location	Average Daily Traffic		Dir Dist %	K Factor	Percent Trucks		ATHWLD	Percent Tandem Axles in ATHWLD	Flexible Pavement	S N	Rigid Pavement	SLAB									
	2030	2050			ADT	DHV															
	Base Year				Base Year																
<u>US 380 Proposed Mainlanes</u> From Coit Road to FM 1827 Segment C From McDonald Street To FM 1827 Collin County										70,600	109,000	58 - 42	8.5	5.4	3.2	12,400	40	14,795,000	3	19,935,000	8"
Data for Use in Air & Noise Analysis																					
Vehicle Class	Base Year																				
	% of ADT		% of DHV																		
Light Duty	94.6		96.8																		
Medium Duty	1.9		1.1																		
Heavy Duty	3.5		2.1																		
										Total Number of Equivalent 18k Single Axle Load Applications One Direction Expected for a 30 Year Period (2030 to 2060)											
Description of Location	Average Daily Traffic		Dir Dist %	K Factor	Percent Trucks		ATHWLD	Percent Tandem Axles in ATHWLD	Flexible Pavement	S N	Rigid Pavement	SLAB									
	2030	2060			ADT	DHV															
	Base Year				Base Year																
<u>US 380 Proposed Mainlanes</u> From Coit Road to FM 1827 Segment C From McDonald Street To FM 1827 Collin County										70,600	123,200	58 - 42	8.5	5.4	3.2	12,400	40	23,947,500	3	32,267,000	8"

NOT INTENDED FOR CONSTRUCTION
 BIDDING OR PERMIT PURPOSES
 Dan Perge, P.E.
 Serial Number 77159

TRAFFIC ANALYSIS FOR HIGHWAY DESIGN (Option C)

Dallas District

February 15, 2022

										Total Number of Equivalent 18k Single Axle Load Applications One Direction Expected for a 20 Year Period (2030 to 2050)											
Description of Location	Average Daily Traffic		Dir Dist %	K Factor	Percent Trucks		ATHWLD	Percent Tandem Axles in ATHWLD	Flexible Pavement	S N	Rigid Pavement	SLAB									
	2030	2050			ADT	DHV															
	Base Year				Base Year																
<u>US 380 Proposed Mainlanes</u> From Coit Road to FM 1827 Segment D From McDonald Street To FM 1827 Collin County										84,600	130,900	58 - 42	8.5	5.0	3.0	12,500	40	16,456,000	3	22,160,000	8"
Data for Use in Air & Noise Analysis																					
Vehicle Class	Base Year																				
	% of ADT		% of DHV																		
Light Duty	95.0		97.0																		
Medium Duty	1.8		1.1																		
Heavy Duty	3.2		1.9																		
										Total Number of Equivalent 18k Single Axle Load Applications One Direction Expected for a 30 Year Period (2030 to 2060)											
Description of Location	Average Daily Traffic		Dir Dist %	K Factor	Percent Trucks		ATHWLD	Percent Tandem Axles in ATHWLD	Flexible Pavement	S N	Rigid Pavement	SLAB									
	2030	2060			ADT	DHV															
	Base Year				Base Year																
<u>US 380 Proposed Mainlanes</u> From Coit Road to FM 1827 Segment D From McDonald Street To FM 1827 Collin County										84,600	147,100	58 - 42	8.5	5.0	3.0	12,500	30	26,539,500	3	35,739,000	8"

NOT INTENDED FOR CONSTRUCTION
 BIDDING OR PERMIT PURPOSES
 Dan Perge, P.E.
 Serial Number 77159

TRAFFIC ANALYSIS FOR HIGHWAY DESIGN (Option C)

Dallas District

February 15, 2022

									Total Number of Equivalent 18k Single Axle Load Applications One Direction Expected for a 20 Year Period (2030 to 2050)			
Description of Location	Average Daily Traffic		Dir Dist %	K Factor	Percent Trucks		ATHWLD	Percent Tandem Axles in ATHWLD	Flexible Pavement	S N	Rigid Pavement	SLAB
	2030	2050			ADT	DHV						
	Base Year				Base Year							
Data for Use in Air & Noise Analysis												
Vehicle Class	Base Year											
	% of ADT		% of DHV									
Light Duty	95.1		97.1									
Medium Duty	1.8		1.1									
Heavy Duty	3.1		1.8									
									Total Number of Equivalent 18k Single Axle Load Applications One Direction Expected for a 30 Year Period (2030 to 2060)			
Description of Location	Average Daily Traffic		Dir Dist %	K Factor	Percent Trucks		ATHWLD	Percent Tandem Axles in ATHWLD	Flexible Pavement	S N	Rigid Pavement	SLAB
	2030	2060			ADT	DHV						
	Base Year				Base Year							
<u>US 380 Proposed Mainlanes</u> From Coit Road to FM 1827												
Segment E From Future Bloomdale Road To McDonald Street Collin County	89,600	155,800	58 - 42	8.5	4.9	2.9	12,600	30	27,555,000	3	37,100,500	8"

NOT INTENDED FOR CONSTRUCTION
BIDDING OR PERMIT PURPOSES
Dan Perge, P.E.
Serial Number 77159

TRAFFIC ANALYSIS FOR HIGHWAY DESIGN (Option C)

Dallas District

February 15, 2022

									Total Number of Equivalent 18k Single Axle Load Applications One Direction Expected for a 20 Year Period (2030 to 2050)			
Description of Location	Average Daily Traffic		Dir Dist %	K Factor	Percent Trucks		ATHWLD	Percent Tandem Axles in ATHWLD	Flexible Pavement	S N	Rigid Pavement	SLAB
	2030	2050			ADT	DHV						
	Base Year				Base Year							
Data for Use in Air & Noise Analysis												
Vehicle Class	Base Year											
	% of ADT		% of DHV									
Light Duty	96.3		97.2									
Medium Duty	1.3		1.0									
Heavy Duty	2.4		1.8									
									Total Number of Equivalent 18k Single Axle Load Applications One Direction Expected for a 30 Year Period (2030 to 2060)			
Description of Location	Average Daily Traffic		Dir Dist %	K Factor	Percent Trucks		ATHWLD	Percent Tandem Axles in ATHWLD	Flexible Pavement	S N	Rigid Pavement	SLAB
	2030	2060			ADT	DHV						
	Base Year				Base Year							
<u>US 380 Proposed Frontage Roads</u> From Coit Road to FM 1827 Segment A From Coit Road To Future Bloomdale Road Collin County	30,000	45,900	58 - 42	8.5	3.7	2.8	11,400	30	3,321,500	3	4,057,000	8"
<u>US 380 Proposed Frontage Roads</u> From Coit Road to FM 1827 Segment A From Coit Road To Future Bloomdale Road Collin County	30,000	53,000	58 - 42	8.5	3.7	2.8	11,500	30	5,448,000	3	6,655,000	8"

NOT INTENDED FOR CONSTRUCTION
BIDDING OR PERMIT PURPOSES
Dan Perge, P.E.
Serial Number 77159

TRAFFIC ANALYSIS FOR HIGHWAY DESIGN (Option C)

Dallas District

February 15, 2022

										Total Number of Equivalent 18k Single Axle Load Applications One Direction Expected for a 20 Year Period (2030 to 2050)											
Description of Location	Average Daily Traffic		Dir Dist %	K Factor	Percent Trucks		ATHWLD	Percent Tandem Axles in ATHWLD	Flexible Pavement	S N	Rigid Pavement	SLAB									
	2030	2050			ADT	DHV															
	Base Year				Base Year																
<u>US 380 Proposed Frontage Roads</u> From Coit Road to FM 1827																					
Segment B From Coit Road To Future Bloomdale Road										21,900	33,700	58 - 42	8.5	3.7	2.8	11,100	40	2,433,000	3	2,972,000	8"
Collin County																					
Data for Use in Air & Noise Analysis																					
Vehicle Class	Base Year																				
	% of ADT		% of DHV																		
Light Duty	96.3		97.2																		
Medium Duty	1.3		1.0																		
Heavy Duty	2.4		1.8																		
										Total Number of Equivalent 18k Single Axle Load Applications One Direction Expected for a 30 Year Period (2030 to 2060)											
Description of Location	Average Daily Traffic		Dir Dist %	K Factor	Percent Trucks		ATHWLD	Percent Tandem Axles in ATHWLD	Flexible Pavement	S N	Rigid Pavement	SLAB									
	2030	2060			ADT	DHV															
	Base Year				Base Year																
<u>US 380 Proposed Frontage Roads</u> From Coit Road to FM 1827																					
Segment B From Coit Road To Future Bloomdale Road										21,900	37,900	58 - 42	8.5	3.7	2.8	11,200	40	3,925,500	3	4,795,000	8"
Collin County																					

NOT INTENDED FOR CONSTRUCTION
 BIDDING OR PERMIT PURPOSES
 Dan Perge, P.E.
 Serial Number 77159

TRAFFIC ANALYSIS FOR HIGHWAY DESIGN (Option C)

Dallas District

February 15, 2022

										Total Number of Equivalent 18k Single Axle Load Applications One Direction Expected for a 20 Year Period (2030 to 2050)											
Description of Location	Average Daily Traffic		Dir Dist %	K Factor	Percent Trucks		ATHWLD	Percent Tandem Axles in ATHWLD	Flexible Pavement	S N	Rigid Pavement	SLAB									
	2030	2050			ADT	DHV															
	Base Year				Base Year																
US 380 Proposed Frontage Roads From Coit Road to FM 1827																					
<u>Segment C</u> From McDonald Street To FM 1827										21,700	32,300	58 - 42	8.5	3.7	2.8	11,100	40	2,363,000	3	2,886,500	8"
Collin County																					
Data for Use in Air & Noise Analysis																					
Vehicle Class	Base Year																				
	% of ADT		% of DHV																		
Light Duty	96.3		97.2																		
Medium Duty	1.3		1.0																		
Heavy Duty	2.4		1.8																		
										Total Number of Equivalent 18k Single Axle Load Applications One Direction Expected for a 30 Year Period (2030 to 2060)											
Description of Location	Average Daily Traffic		Dir Dist %	K Factor	Percent Trucks		ATHWLD	Percent Tandem Axles in ATHWLD	Flexible Pavement	S N	Rigid Pavement	SLAB									
	2030	2060			ADT	DHV															
	Base Year				Base Year																
US 380 Proposed Frontage Roads From Coit Road to FM 1827																					
<u>Segment C</u> From McDonald Street To FM 1827										21,700	37,300	58 - 42	8.5	3.7	2.8	11,200	40	3,873,000	3	4,730,500	8"
Collin County																					

NOT INTENDED FOR CONSTRUCTION
 BIDDING OR PERMIT PURPOSES
 Dan Perge, P.E.
 Serial Number 77159

TRAFFIC ANALYSIS FOR HIGHWAY DESIGN (Option C)

Dallas District

February 15, 2022

										Total Number of Equivalent 18k Single Axle Load Applications One Direction Expected for a 20 Year Period (2030 to 2050)											
Description of Location	Average Daily Traffic		Dir Dist %	K Factor	Percent Trucks		ATHWLD	Percent Tandem Axles in ATHWLD	Flexible Pavement	S N	Rigid Pavement	SLAB									
	2030	2050			ADT	DHV															
	Base Year				Base Year																
<u>US 380 Proposed Frontage Roads</u> From Coit Road to FM 1827																					
Segment D (Section #1) From McDonald Street To Entrance From Airport Drive										6,900	10,500	58 - 42	8.5	5.8	4.4	10,800	40	1,182,000	3	1,450,500	8"
Collin County																					
Data for Use in Air & Noise Analysis																					
Vehicle Class	Base Year																				
	% of ADT		% of DHV																		
Light Duty	94.2		95.6																		
Medium Duty	2.1		1.6																		
Heavy Duty	3.7		2.8																		
										Total Number of Equivalent 18k Single Axle Load Applications One Direction Expected for a 30 Year Period (2030 to 2060)											
Description of Location	Average Daily Traffic		Dir Dist %	K Factor	Percent Trucks		ATHWLD	Percent Tandem Axles in ATHWLD	Flexible Pavement	S N	Rigid Pavement	SLAB									
	2030	2060			ADT	DHV															
	Base Year				Base Year																
<u>US 380 Proposed Frontage Roads</u> From Coit Road to FM 1827																					
Segment D (Section #1) From McDonald Street To Entrance From Airport Drive										6,900	12,000	58 - 42	8.5	5.8	4.4	10,800	40	1,926,000	3	2,363,000	8"
Collin County																					

NOT INTENDED FOR CONSTRUCTION
 BIDDING OR PERMIT PURPOSES
 Dan Perge, P.E.
 Serial Number 77159

TRAFFIC ANALYSIS FOR HIGHWAY DESIGN (Option C)

Dallas District

February 15, 2022

										Total Number of Equivalent 18k Single Axle Load Applications One Direction Expected for a 20 Year Period (2030 to 2050)											
Description of Location	Average Daily Traffic		Dir Dist %	K Factor	Percent Trucks		ATHWLD	Percent Tandem Axles in ATHWLD	Flexible Pavement	S N	Rigid Pavement	SLAB									
	2030	2050			ADT	DHV															
	Base Year				Base Year																
US 380 Proposed Frontage Roads From Coit Road to FM 1827																					
<u>Segment D (Section #2)</u> From Entrance From Airport Drive To FM 1827										25,100	37,600	58 - 42	8.5	3.6	2.7	11,200	40	2,671,500	3	3,262,000	8"
Collin County																					
Data for Use in Air & Noise Analysis																					
Vehicle Class	Base Year																				
	% of ADT		% of DHV																		
Light Duty	96.4		97.3																		
Medium Duty	1.3		1.0																		
Heavy Duty	2.3		1.7																		
										Total Number of Equivalent 18k Single Axle Load Applications One Direction Expected for a 30 Year Period (2030 to 2060)											
Description of Location	Average Daily Traffic		Dir Dist %	K Factor	Percent Trucks		ATHWLD	Percent Tandem Axles in ATHWLD	Flexible Pavement	S N	Rigid Pavement	SLAB									
	2030	2060			ADT	DHV															
	Base Year				Base Year																
US 380 Proposed Frontage Roads From Coit Road to FM 1827																					
<u>Segment D (Section #2)</u> From Entrance From Airport Drive To FM 1827										25,100	43,000	58 - 42	8.5	3.6	2.7	11,300	30	4,352,500	3	5,315,000	8"
Collin County																					

NOT INTENDED FOR CONSTRUCTION
 BIDDING OR PERMIT PURPOSES
 Dan Perge, P.E.
 Serial Number 77159

TRAFFIC ANALYSIS FOR HIGHWAY DESIGN (Option C)

Dallas District

February 15, 2022

										Total Number of Equivalent 18k Single Axle Load Applications One Direction Expected for a 20 Year Period (2030 to 2050)											
Description of Location	Average Daily Traffic		Dir Dist %	K Factor	Percent Trucks		ATHWLD	Percent Tandem Axles in ATHWLD	Flexible Pavement	S N	Rigid Pavement	SLAB									
	2030	2050			ADT	DHV															
	Base Year				Base Year																
<u>US 380 Proposed Frontage Roads</u> From Coit Road to FM 1827																					
Segment E From Future Bloomdale Road To McDonald Street										30,700	47,500	58 - 42	8.5	3.6	2.7	11,400	30	3,332,000	3	4,068,500	8"
Collin County																					
Data for Use in Air & Noise Analysis																					
Vehicle Class	Base Year																				
	% of ADT		% of DHV																		
Light Duty	96.4		97.3																		
Medium Duty	1.3		1.0																		
Heavy Duty	2.3		1.7																		
										Total Number of Equivalent 18k Single Axle Load Applications One Direction Expected for a 30 Year Period (2030 to 2060)											
Description of Location	Average Daily Traffic		Dir Dist %	K Factor	Percent Trucks		ATHWLD	Percent Tandem Axles in ATHWLD	Flexible Pavement	S N	Rigid Pavement	SLAB									
	2030	2060			ADT	DHV															
	Base Year				Base Year																
<u>US 380 Proposed Frontage Roads</u> From Coit Road to FM 1827																					
Segment E From Future Bloomdale Road To McDonald Street										30,700	53,700	58 - 42	8.5	3.6	2.7	11,500	30	5,394,500	3	6,587,000	8"
Collin County																					

NOT INTENDED FOR CONSTRUCTION
 BIDDING OR PERMIT PURPOSES
 Dan Perge, P.E.
 Serial Number 77159

1 Coit Rd @ US 380

Year	2020
ADT	9300
K-factor	9.4
D-factor	52
Truck%	6.4
SingleUnit'	4.7
ComboUni	1.7

Year	2020
ADT	42900
K-factor	8.5
D-factor	55
Truck%	7.5
SingleUnit'	3.7
ComboUni	3.8

Year	2020
ADT	45700
K-factor	8.5
D-factor	55
Truck%	7.5
SingleUnit'	3.7
ComboUni	3.8

Year	2020
ADT	12100
K-factor	16.4
D-factor	65
Truck%	3.2
SingleUnit'	1.8
ComboUni	1.4

2 Prestwick Hollow Dr @ US 380

Year	2020
ADT	48000
K-factor	8.5
D-factor	55
Truck%	7.5
SingleUnit'	3.7
ComboUni	3.8

Year	2020
ADT	42900
K-factor	8.5
D-factor	55
Truck%	7.5
SingleUnit'	3.7
ComboUni	3.8

Year	2020
ADT	1100
K-factor	14
D-factor	60
Truck%	3.2
SingleUnit'	1.8
ComboUni	1.4

3 Lakewood Dr @ US 380

Year	2020
ADT	800
K-factor	8.5
D-factor	55
Truck%	7.5
SingleUnit'	3.7
ComboUni	3.8

Year	2020
ADT	48000
K-factor	8.5
D-factor	55
Truck%	7.5
SingleUnit'	3.7
ComboUni	3.8

Year	2020
ADT	48000
K-factor	8.5
D-factor	55
Truck%	7.5
SingleUnit'	3.7
ComboUni	3.8

4 Custer Rd @ US 380

Year	2020
ADT	13900
K-factor	8.2
D-factor	52
Truck%	3.7
SingleUnit'	2.6
ComboUni	1.1

Year	2020
ADT	43800
K-factor	8.6
D-factor	53
Truck%	6.5
SingleUnit'	3.3
ComboUni	3.2

Year	2020
ADT	41400
K-factor	8.5
D-factor	55
Truck%	7.5
SingleUnit'	3.7
ComboUni	3.8

Year	2020
ADT	23000
K-factor	8.5
D-factor	51
Truck%	3.7
SingleUnit'	2.5
ComboUni	1.2

5 Stonebridge Dr @ US 380

Year	2020
ADT	40400
K-factor	8.6
D-factor	53
Truck%	6.5
SingleUnit'	3.3
ComboUni	3.2

Year	2020
ADT	43800
K-factor	8.6
D-factor	53
Truck%	6.5
SingleUnit'	3.3
ComboUni	3.2

Year	2020
ADT	7500
K-factor	10.8
D-factor	58
Truck%	3.2
SingleUnit'	1.8
ComboUni	1.4

6 CR 933

Year	2020
ADT	20
K-factor	10.2
D-factor	60
Truck%	3.2
SingleUnit'	1.8
ComboUni	1.4

Year	2020
ADT	20
K-factor	10.2
D-factor	60
Truck%	3.2
SingleUnit'	1.8
ComboUni	1.4

7

Custer Rd @ County Rd

Year	2020
ADT	13900
K-factor	8.2
D-factor	62
Truck%	3.8
SingleUnit'	2.7
ComboUni	1.1

Year	2020
ADT	2700
K-factor	10.9
D-factor	61
Truck%	6
SingleUnit'	3.6
ComboUni	2.4

Year	2020
ADT	13900
K-factor	8.2
D-factor	62
Truck%	3.8
SingleUnit'	2.7
ComboUni	1.1

8

Grassmere Ln @ US 380

Year	2020
ADT	1100
K-factor	10.2
D-factor	60
Truck%	3.2
SingleUnit'	1.8
ComboUni	1.4

Year	2020
ADT	41700
K-factor	8.6
D-factor	53
Truck%	6.5
SingleUnit'	3.3
ComboUni	3.2

Year	2020
ADT	40400
K-factor	8.6
D-factor	53
Truck%	6.5
SingleUnit'	3.3
ComboUni	3.2

Year	2020
ADT	1300
K-factor	10.2
D-factor	60
Truck%	3.2
SingleUnit'	1.8
ComboUni	1.4

Year	2019
ADT	700
K-factor	11.2
D-factor	60
Truck%	3.2
SingleUnit'	1.8
ComboUni	1.4

Year	2019
ADT	700
K-factor	11.2
D-factor	60
Truck%	3.2
SingleUnit'	1.8
ComboUni	1.4

Year	2020
ADT	20
K-factor	11.2
D-factor	60
Truck%	3.2
SingleUnit'	1.8
ComboUni	1.4

Year	2020
ADT	80
K-factor	10.2
D-factor	60
Truck%	3.2
SingleUnit'	1.8
ComboUni	1.4

Year	2020
ADT	2700
K-factor	10.2
D-factor	60
Truck%	3.2
SingleUnit'	1.8
ComboUni	1.4

Year	2020
ADT	2900
K-factor	10.2
D-factor	60
Truck%	3.2
SingleUnit'	1.8
ComboUni	1.4

Year	2020
ADT	400
K-factor	10.2
D-factor	60
Truck%	3.2
SingleUnit'	1.8
ComboUni	1.4

Year	2020
ADT	6900
K-factor	9.7
D-factor	62
Truck%	6.7
SingleUnit'	3.3
ComboUni	3.4

Year	2020
ADT	200
K-factor	10.2
D-factor	60
Truck%	3.2
SingleUnit'	1.8
ComboUni	1.4

Year	2020
ADT	2700
K-factor	10.2
D-factor	60
Truck%	3.2
SingleUnit'	1.8
ComboUni	1.4

Year	2020
ADT	10400
K-factor	8.3
D-factor	50
Truck%	2.8
SingleUnit'	2
ComboUni	0.8

12 CR 164 @ CR 201

Year	2020
ADT	170
K-factor	15
D-factor	60
Truck%	2.9
SingleUnit'	1.7
ComboUni	1.2

Year	2020
ADT	170
K-factor	15
D-factor	60
Truck%	2.9
SingleUnit'	1.7
ComboUni	1.2

Year	2020
ADT	170
K-factor	10.2
D-factor	60
Truck%	3.2
SingleUnit'	1.8
ComboUni	1.4

13 Community Avenue @ CR 201

Year	2020
ADT	170
K-factor	10.2
D-factor	60
Truck%	3.2
SingleUnit'	1.8
ComboUni	1.4

Year	2020
ADT	170
K-factor	10.2
D-factor	60
Truck%	3.2
SingleUnit'	1.8
ComboUni	1.4

Year	2020
ADT	2700
K-factor	13.3
D-factor	60
Truck%	3.2
SingleUnit'	1.8
ComboUni	1.4

14 Bloomdale Rd @ US 75

		US 75 SBFR	US 75 Mainlane	US 75 NBFR	
Year	2020	Year	2020	Year	2020
ADT	5600	ADT	72700	ADT	2600
K-factor	10.8	K-factor	10	K-factor	26.1
D-factor	100	D-factor	66	D-factor	61
Truck%	6.5	Truck%	14	Truck%	3.2
SingleUnit'	4.6	SingleUnit'	3.9	SingleUnit'	1.8
ComboUni	1.9	ComboUni	10.1	ComboUni	1.4
Year 2020		Year 2020		Year 2020	
ADT 3700		ADT 72700		ADT 5600	
K-factor 26.1		K-factor 10		K-factor 10.5	
D-factor 61		D-factor 66		D-factor 100	
Truck% 3.2		Truck% 14		Truck% 6.4	
SingleUnit 1.8		SingleUnit' 3.9		SingleUnit' 4.6	
ComboUni 1.4		ComboUni 10.1		ComboUni 1.9	
		US 75 SBFR	US 75 Mainlane	US 75 NBFR	

15 Spur 195 @ US 75

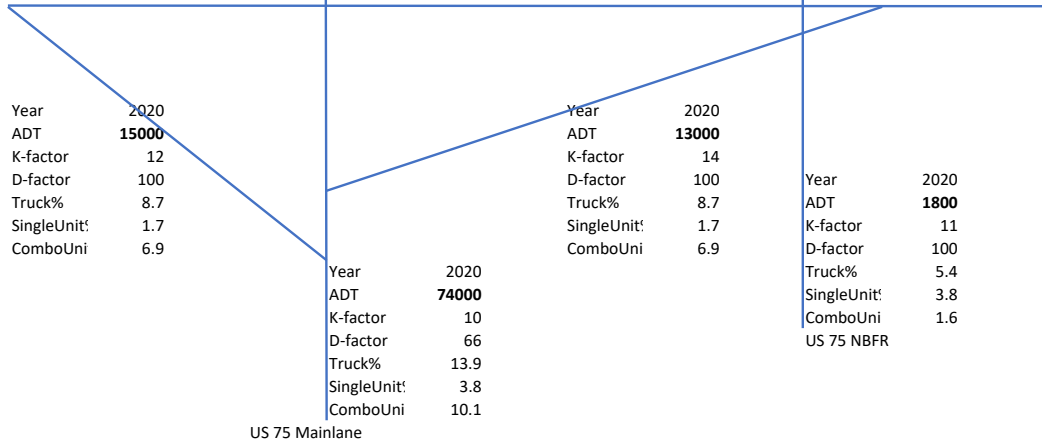
		US 75 SBFR	US 75 Mainlane	US 75 NBFR	
Year	2020	Year	2020	Year	2020
ADT	2300	ADT	72700	ADT	3200
K-factor	10.8	K-factor	10	K-factor	10
D-factor	100	D-factor	66	D-factor	60
Truck%	6.5	Truck%	14	Truck%	8.5
SingleUnit'	4.6	SingleUnit'	3.9	SingleUnit'	7.4
ComboUni	1.9	ComboUni	10.1	ComboUni	1.2
Year 2020		Year 2020		Year 2020	
ADT 11100		ADT 72700		ADT 5600	
K-factor 10.2		K-factor 10		K-factor 10.5	
D-factor 51		D-factor 66		D-factor 100	
Truck% 3.2		Truck% 14		Truck% 6.4	
SingleUnit 1.8		SingleUnit' 3.9		SingleUnit' 4.6	
ComboUni 1.4		ComboUni 10.1		ComboUni 1.9	
		US 75 SBFR	US 75 Mainlane	US 75 NBFR	

16 121 @ US 75

US 75 SBFR	
Year	2020
ADT	2200
K-factor	8.2
D-factor	100
Truck%	5.5
SingleUnit [†]	3.9
ComboUni	1.6

US 75 Mainlane	
Year	2020
ADT	51000
K-factor	10
D-factor	66
Truck%	15.3
SingleUnit [†]	3.1
ComboUni	12.2

US 75 NBFR



US 75 SBFR

US 75 Mainlane

US 75 NBFR

17 Davis Rd @ US 75

US 75 SBFR	
Year	2020
ADT	2200
K-factor	8.2
D-factor	100
Truck%	5.5
SingleUnit [†]	3.9
ComboUni	1.6

US 75 Mainlane	
Year	2020
ADT	51000
K-factor	10
D-factor	66
Truck%	15.3
SingleUnit [†]	3.1
ComboUni	12.2

US 75 NBFR

US 75 NBFR	
Year	2020
ADT	11300
K-factor	13.5
D-factor	60
Truck%	5.4
SingleUnit [†]	2.7
ComboUni	2.7

US 75 SBFR	
Year	2020
ADT	51000
K-factor	10
D-factor	66
Truck%	15.3
SingleUnit [†]	3.1
ComboUni	12.2

US 75 Mainlane	
Year	2020
ADT	51000
K-factor	10
D-factor	66
Truck%	15.3
SingleUnit [†]	3.1
ComboUni	12.2

US 75 NBFR	
Year	2020
ADT	5100
K-factor	10.8
D-factor	60
Truck%	7
SingleUnit [†]	4.9
ComboUni	2

US 75 SBFR

US 75 Mainlane

US 75 NBFR

18

McDonald St (North of Spur 195)

Year	2020
ADT	8200
K-factor	8.5
D-factor	58
Truck%	8.4
SingleUnit%	7.2
ComboUni	1.2

Year	2020
ADT	8200
K-factor	8.5
D-factor	58
Truck%	8.4
SingleUnit%	7.2
ComboUni	1.2

19

CR 338

Year	2020
ADT	480
K-factor	30
D-factor	61
Truck%	5.8
SingleUnit%	3.5
ComboUni	2.3

Year	2020
ADT	480
K-factor	30
D-factor	61
Truck%	5.8
SingleUnit%	3.5
ComboUni	2.3

12 CR 331 @ FM 2933

Year	2020
ADT	7122
K-factor	10.5
D-factor	62
Truck%	10.6
SingleUnit%	3.5
ComboUni	7.1

Year	2020
ADT	1022
K-factor	10.9
D-factor	61
Truck%	6
SingleUnit%	3.6
ComboUni	2.4

Year	2020
ADT	3722
K-factor	10.5
D-factor	62
Truck%	10.6
SingleUnit%	3.5
ComboUni	7.1

13 FM 2933 @ Wayside Trl

Year	2020
ADT	3722
K-factor	11
D-factor	62
Truck%	13.5
SingleUnit%	4.5
ComboUni	9

Year	2020
ADT	32
K-factor	11
D-factor	62
Truck%	13.5
SingleUnit%	4.5
ComboUni	9

Year	2020
ADT	3722
K-factor	11
D-factor	62
Truck%	13.5
SingleUnit%	4.5
ComboUni	9

22 FM 2933 @ CR 335

Year	2020	Year	2020
ADT	1300	ADT	1300
K-factor	11	K-factor	11
D-factor	62	D-factor	62
Truck%	13.5	Truck%	13.5
SingleUnit'	4.5	SingleUnit'	4.5
ComboUni	9	ComboUni	9

23 FM 2933 @ CR 332

Year	2020	Year	2020	Year	2020
ADT	40	ADT	1300	ADT	1500
K-factor	17.1	K-factor	11	K-factor	11.3
D-factor	60	D-factor	62	D-factor	62
Truck%	2.9	Truck%	13.5	Truck%	12.7
SingleUnit'	2.9	SingleUnit'	4.5	SingleUnit'	4.2
ComboUni	0	ComboUni	9	ComboUni	8.5

24 CR 332 @ Peacock Trl

Year	2020
ADT	100
K-factor	10.2
D-factor	60
Truck%	3.2
SingleUnit%	1.8
ComboUni	1.4

25 FM 1827 @ US 380

Year	2020
ADT	5100
K-factor	8.3
D-factor	62
Truck%	5.1
SingleUnit%	3.6
ComboUni	1.5

Year	2020
ADT	40400
K-factor	9.2
D-factor	67
Truck%	4
SingleUnit%	2.5
ComboUni	1.5

Year	2020
ADT	47000
K-factor	8.9
D-factor	61
Truck%	4.5
SingleUnit%	2.8
ComboUni	1.7

26 CR 274

Year	2020
ADT	1800
K-factor	10.9
D-factor	60
Truck%	3.2
SingleUnit%	1.8
ComboUni	1.4

Year	2020
ADT	1800
K-factor	10.9
D-factor	60
Truck%	3.2
SingleUnit%	1.8
ComboUni	1.4

27 Woodlawn Rd

Year	2020
ADT	1200
K-factor	13.3
D-factor	60
Truck%	3.2
SingleUnit%	1.8
ComboUni	1.4

Year	2020
ADT	1200
K-factor	13.3
D-factor	60
Truck%	3.2
SingleUnit%	1.8
ComboUni	1.4

28 Airport Dr @ US 380

Year	2020
ADT	47000
K-factor	8.9
D-factor	61
Truck%	4.5
SingleUnit%	2.8
ComboUni	1.7

Year	2020
ADT	31700
K-factor	8.9
D-factor	61
Truck%	4.5
SingleUnit%	2.8
ComboUni	1.7

Year	2020
ADT	16400
K-factor	8.1
D-factor	60
Truck%	12.9
SingleUnit%	7.3
ComboUni	5.6

29 Privite Road 5092 @ US 380

Year	2020
ADT	40400
K-factor	9.2
D-factor	67
Truck%	4
SingleUnit'	2.5
ComboUni	1.5

Year	2020
ADT	40400
K-factor	9.2
D-factor	67
Truck%	4
SingleUnit'	2.5
ComboUni	1.5

Driveway to McKinney C&D Landfill

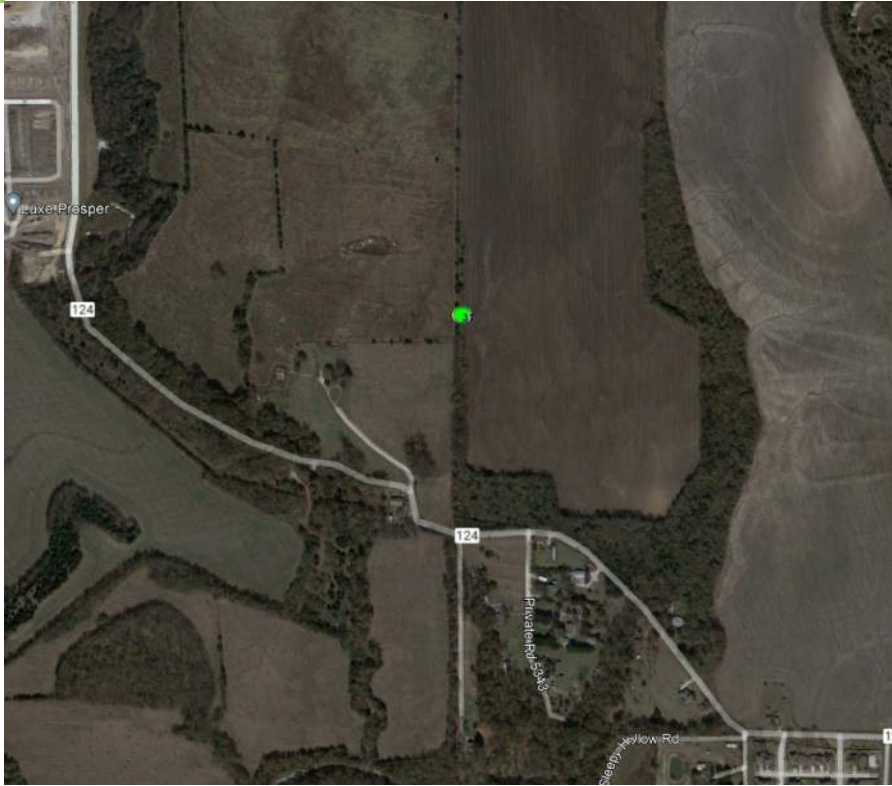
30 Privite Road 5446 @ US 380

Year	2020
ADT	40400
K-factor	9.2
D-factor	67
Truck%	4
SingleUnit'	2.5
ComboUni	1.5

Year	2020
ADT	40400
K-factor	9.2
D-factor	67
Truck%	4
SingleUnit'	2.5
ComboUni	1.5

Year	2020
ADT	300
K-factor	9.2
D-factor	50
Truck%	4
SingleUnit'	2.5
ComboUni	1.5

31 There isn't a road at this location.



32 CR 1006 @ CR 164

Year	2020
ADT	80
K-factor	10.2
D-factor	60
Truck%	3.2
SingleUnit%	1.8
ComboUni	1.4

Year	2020
ADT	500
K-factor	10.3
D-factor	60
Truck%	3.1
SingleUnit%	2.1
ComboUni	1

Year	2020
ADT	500
K-factor	10.3
D-factor	60
Truck%	3.1
SingleUnit%	2.1
ComboUni	1

Year	2020
ADT	500
K-factor	10.2
D-factor	60
Truck%	3.2
SingleUnit'	1.8
ComboUni	1.4

Year	2020
ADT	500
K-factor	10.2
D-factor	60
Truck%	3.2
SingleUnit'	1.8
ComboUni	1.4

a

Red Bud Dr @ University Dr

Year -
 ADT -
 K-factor -
 D-factor -
 Truck% -
 SingleUnit! -
 ComboUni -

Year -
 ADT -
 K-factor -
 D-factor -
 Truck% -
 SingleUnit! -
 ComboUni -

Year	2020
ADT	580
K-factor	9.9
D-factor	60
Truck%	3.2
SingleUnit!	1.8
ComboUni	1.4

b

CR 852 @ University Dr

Year	2020
ADT	200
K-factor	10.2
D-factor	60
Truck%	3.2
SingleUnit!	1.8
ComboUni	1.4

Year -
 ADT -
 K-factor -
 D-factor -
 Truck% -
 SingleUnit! -
 ComboUni -

Year -
 ADT -
 K-factor -
 D-factor -
 Truck% -
 SingleUnit! -
 ComboUni -

c CR 856 @ Univeristy Dr

Year	2020
ADT	170
K-factor	10.2
D-factor	60
Truck%	3.2
SingleUnit!	1.8
ComboUni	1.4

Year	-
ADT	-
K-factor	-
D-factor	-
Truck%	-
SingleUnit!	-
ComboUni	-

Year	-
ADT	-
K-factor	-
D-factor	-
Truck%	-
SingleUnit!	-
ComboUni	-

d Tremont @ University Dr

Year	2020
ADT	2100
K-factor	10.2
D-factor	60
Truck%	3.2
SingleUnit!	1.8
ComboUni	1.4

Year	2020
ADT	40400
K-factor	8.6
D-factor	53
Truck%	6.5
SingleUnit!	3.3
ComboUni	3.2

Year	2020
ADT	40400
K-factor	8.6
D-factor	53
Truck%	6.5
SingleUnit!	3.3
ComboUni	3.2

e Custer Rd @ E. 1st/ Easy Ln
(Same as Point #7)

Year	2020
ADT	13900
K-factor	8.2
D-factor	62
Truck%	3.8
SingleUnit%	2.7
ComboUni	1.1

Year	2020
ADT	100
K-factor	10.2
D-factor	60
Truck%	3.2
SingleUnit%	1.8
ComboUni	1.4

Easy Ln

E. 1st

Year	2020
ADT	2700
K-factor	10.9
D-factor	61
Truck%	6
SingleUnit%	3.6
ComboUni	2.4

Year	2020
ADT	13900
K-factor	8.2
D-factor	62
Truck%	3.8
SingleUnit%	2.7
ComboUni	1.1

All below points volumes are assumed based on ITE Trip Generation. K, D and other factors are assumed from similar points or closet points.

A1 Freedom @ US 380

Year	2020	Year	2020
ADT	41700	ADT	41700
K-factor	8.6	K-factor	8.6
D-factor	53	D-factor	53
Truck%	6.5	Truck%	6.5
SingleUnit%	3.3	SingleUnit%	3.3
ComboUni	3.2	ComboUni	3.2

Year	2020	Year	2020
ADT	41700	ADT	800
K-factor	8.6	K-factor	10.8
D-factor	53	D-factor	58
Truck%	6.5	Truck%	3.2
SingleUnit%	3.3	SingleUnit%	1.8
ComboUni	3.2	ComboUni	1.4

A2 Forest Ridge Ln @ US 380

Year	2020	Year	2020
ADT	41700	ADT	41700
K-factor	8.6	K-factor	8.6
D-factor	53	D-factor	53
Truck%	6.5	Truck%	6.5
SingleUnit%	3.3	SingleUnit%	3.3
ComboUni	3.2	ComboUni	3.2

Year	2020	Year	2020
ADT	41700	ADT	4200
K-factor	8.6	K-factor	10.2
D-factor	53	D-factor	60
Truck%	6.5	Truck%	3.2
SingleUnit%	3.3	SingleUnit%	1.8
ComboUni	3.2	ComboUni	1.4

A3 Baneberry Ln @ Bloomdale Rd

Year -
 ADT -
 K-factor -
 D-factor -
 Truck% -
 SingleUnit! -
 ComboUni -

Year	-	Year	2020
ADT	-	ADT	200
K-factor	-	K-factor	10.2
D-factor	-	D-factor	60
Truck%	-	Truck%	3.2
SingleUnit!	-	SingleUnit!	1.8
ComboUni	-	ComboUni	1.4

A4 Bluewood Ln @ Bloomdale Rd

Year -
 ADT -
 K-factor -
 D-factor -
 Truck% -
 SingleUnit! -
 ComboUni -

Year	-	Year	2020
ADT	-	ADT	1600
K-factor	-	K-factor	10.2
D-factor	-	D-factor	60
Truck%	-	Truck%	3.2
SingleUnit!	-	SingleUnit!	1.8
ComboUni	-	ComboUni	1.4

A5 Bluewood Ln @ Grove Cove Dr

Year 2020
 ADT **1600**
 K-factor 10.2
 D-factor 60
 Truck% 3.2
 SingleUnit\$ 1.8
 ComboUni 1.4

Year 2020
 ADT **300**
 K-factor 10.2
 D-factor 60
 Truck% 3.2
 SingleUnit\$ 1.8
 ComboUni 1.4

Year 2020
 ADT **400**
 K-factor 10.2
 D-factor 60
 Truck% 3.2
 SingleUnit\$ 1.8
 ComboUni 1.4

Year 2020
 ADT **1600**
 K-factor 10.2
 D-factor 60
 Truck% 3.2
 SingleUnit\$ 1.8
 ComboUni 1.4

A6 CR 943 @ Bloomdale Rd

Year -
 ADT -
 K-factor -
 D-factor -
 Truck% -
 SingleUnit\$ -
 ComboUni -

Year -
 ADT -
 K-factor -
 D-factor -
 Truck% -
 SingleUnit\$ -
 ComboUni -

Year 2020
 ADT **400**
 K-factor 10.2
 D-factor 60
 Truck% 3.2
 SingleUnit\$ 1.8
 ComboUni 1.4

Year -
ADT -
K-factor -
D-factor -
Truck% -
SingleUnit:-
ComboUni -

Year -
ADT -
K-factor -
D-factor -
Truck% -
SingleUnit:-
ComboUni -

Year 2020
ADT **400**
K-factor 10.2
D-factor 60
Truck% 3.2
SingleUnit: 1.8
ComboUni 1.4

Blue Build Alternative – New Location



Modifications may continue to be made to the alternatives as the project progresses.

NOT TO SCALE

NOT INTENDED FOR CONSTRUCTION,
BIDDING OR PERMIT PURPOSES
DHURVA LAHON, P.E.
SERIAL NUMBER 102185

US 380 BLUE ALT
KEYMAP

Kimley»Horn
F-928

0135-02-065,
ETC. SHEET 1 OF 1

DATE: 7/13/2021
FILE: US380_BLUE_TITLE.dgn



COIT ROAD

12,200	11,800
18,800	18,400
<u>21,300</u>	<u>20,800</u>

3,900
6,200
<u>7,000</u>

39,600
60,400
<u>68,500</u>

3,500
5,500
<u>6,700</u>

47,000
72,100
<u>82,200</u>

WB US 380

47,800
73,100
<u>83,000</u>

WB US 380

3,800	4,300	4,100
5,900	6,500	6,400
<u>6,700</u>	<u>7,100</u>	<u>7,500</u>

EB US 380

46,300
71,400
<u>80,500</u>

3,900
6,100
<u>7,000</u>

38,400
59,100
<u>66,500</u>

4,000
6,200
<u>7,000</u>

4,400	4,000	3,500
6,800	6,100	5,300
<u>7,800</u>	<u>6,800</u>	<u>6,300</u>

EB US 380

46,000
70,800
<u>80,300</u>

SEE SHEET 2 OF 63

NOT TO SCALE

NOT INTENDED FOR CONSTRUCTION,
BIDDING OR PERMIT PURPOSES
DHURVA LAHON, P.E.
SERIAL NUMBER 102185

US 380 BLUE ALT AND
COIT RD
AVERAGE DAILY TRAFFIC
BLUE ALT BUILD VOLUMES

Kimley»Horn
F-928

0135-02-065,
ETC. SHEET 1 OF 63

LEGEND

- XXXX- 2030 AVERAGE DAILY TRAFFIC VOLUMES
- XXXX- 2050 AVERAGE DAILY TRAFFIC VOLUMES
- XXXX- 2060 AVERAGE DAILY TRAFFIC VOLUMES

DATE: 7/13/2021
FILE: US380_BLUE_TRF_01.dgn



SEE SHEET 1 OF 63

SEE SHEET 3 OF 63

47,000
72,100
82,200

WB US 380

EB US 380

46,000
70,800
80,300

ENTRANCE FROM INDEPENDENCE PARKWAY

47,000
72,100
82,200

EXIT TO INDEPENDENCE PARKWAY

46,000
70,800
80,300

WB US 380

47,000
72,100
82,200

EB US 380

46,000
70,800
80,300

NOT TO SCALE

NOT INTENDED FOR CONSTRUCTION,
BIDDING OR PERMIT PURPOSES
DHURVA LAHON, P.E.
SERIAL NUMBER 102185

US 380 BLUE ALT AND
RAMPS
AVERAGE DAILY TRAFFIC
BLUE ALT BUILD VOLUMES

Kimley»Horn
F-928

0135-02-065,
ETC.

SHEET 2 OF 63

LEGEND

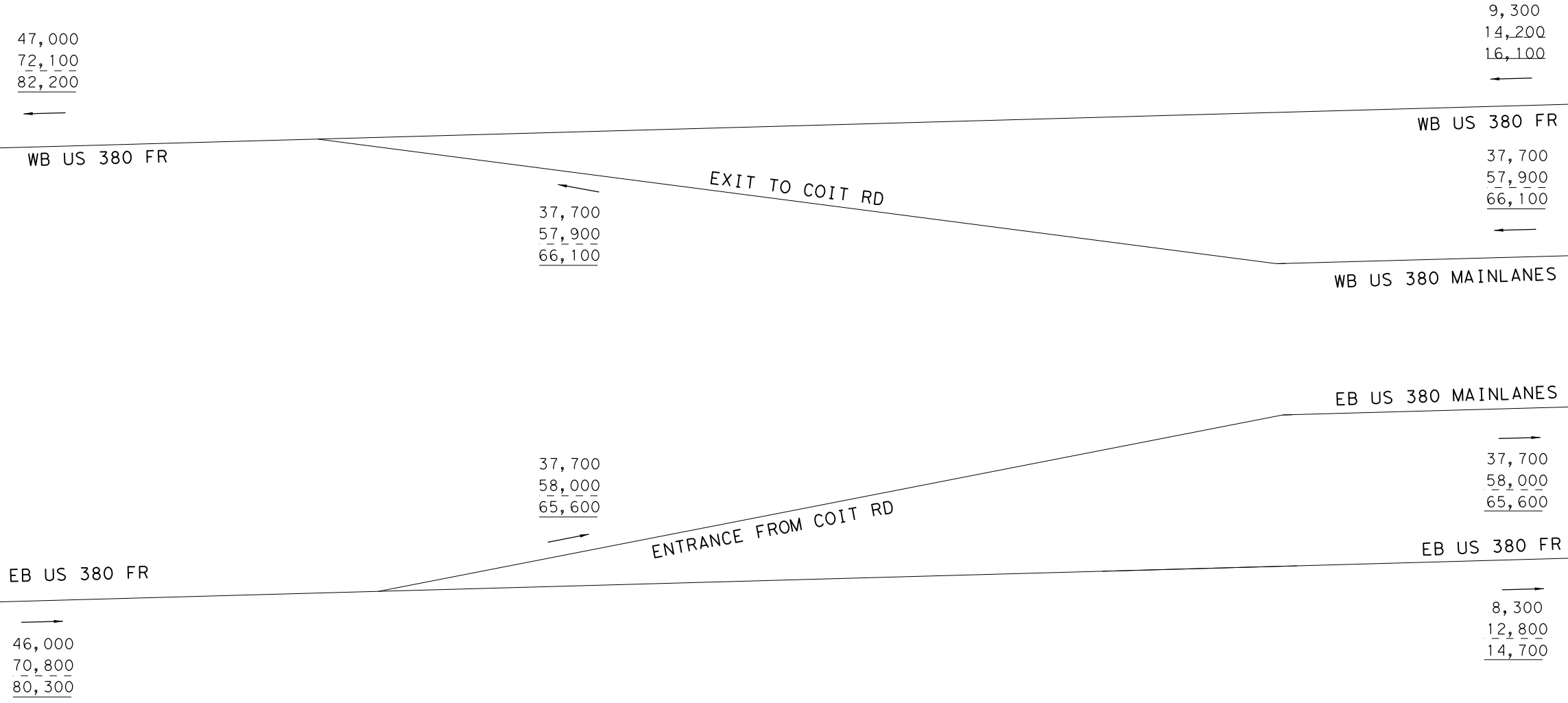
- XXXX- 2030 AVERAGE DAILY TRAFFIC VOLUMES
- XXXX- 2050 AVERAGE DAILY TRAFFIC VOLUMES
- XXXX- 2060 AVERAGE DAILY TRAFFIC VOLUMES

DATE: 7/13/2021
FILE: US380_BLUE_TRF_02.dgn



SEE SHEET 2 OF 63

SEE SHEET 4 OF 63



NOT TO SCALE

NOT INTENDED FOR CONSTRUCTION,
 BIDDING OR PERMIT PURPOSES
 DHRUVA LAHON, P.E.
 SERIAL NUMBER 102185

US 380 BLUE ALT AND
 RAMPS
 AVERAGE DAILY TRAFFIC
 BLUE ALT BUILD VOLUMES



LEGEND

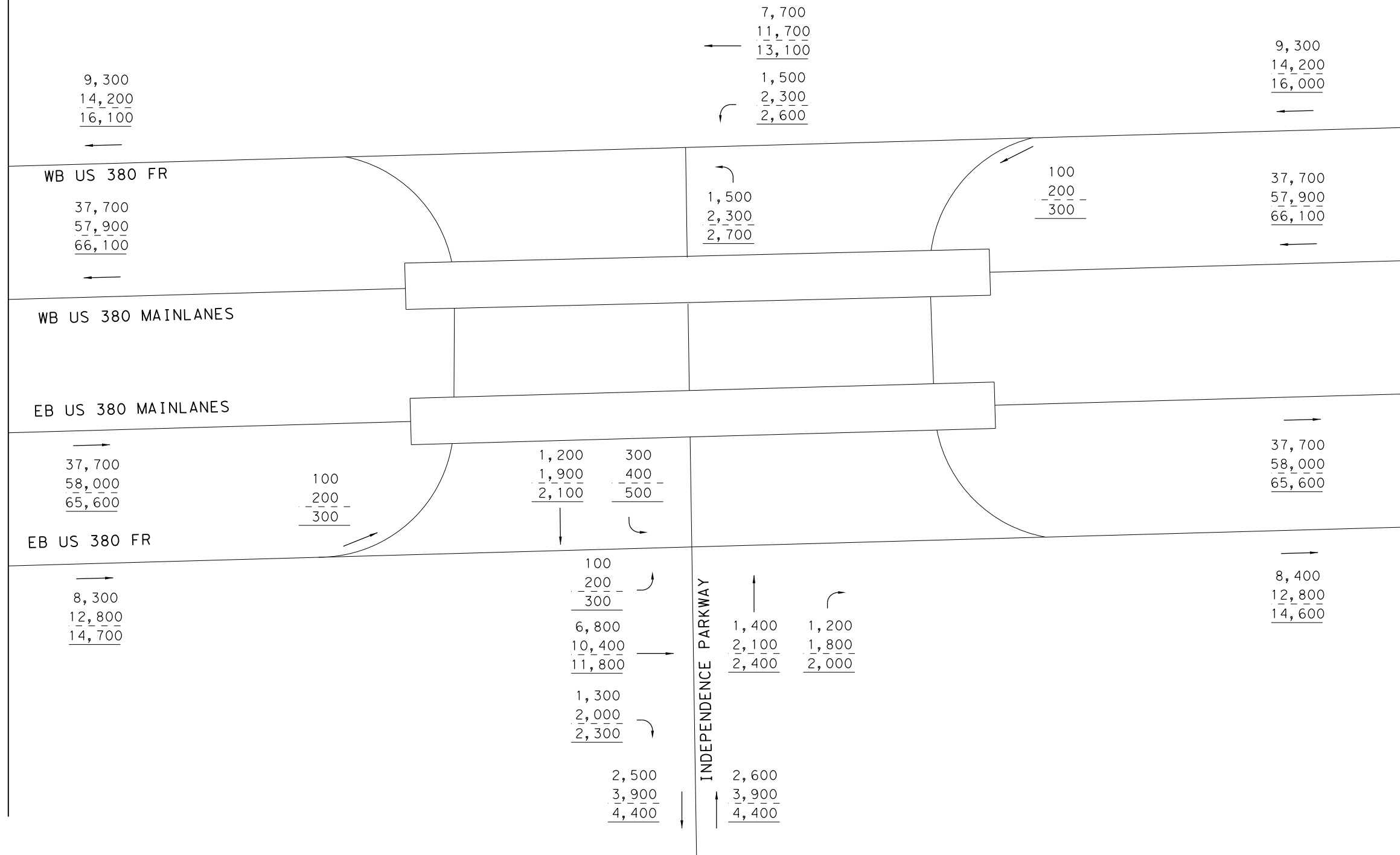
- XXXX- 2030 AVERAGE DAILY TRAFFIC VOLUMES
- XXXX- 2050 AVERAGE DAILY TRAFFIC VOLUMES
- XXXX- 2060 AVERAGE DAILY TRAFFIC VOLUMES

DATE: 7/13/2021
FILE: US380_BLUE_TRF_03.dgn



SEE SHEET 3 OF 63

SEE SHEET 5 OF 63



LEGEND

- XXXX- 2030 AVERAGE DAILY TRAFFIC VOLUMES
- XXXX- 2050 AVERAGE DAILY TRAFFIC VOLUMES
- XXXX- 2060 AVERAGE DAILY TRAFFIC VOLUMES

NOT TO SCALE

NOT INTENDED FOR CONSTRUCTION,
 BIDDING OR PERMIT PURPOSES
 DHRUVA LAHON, P.E.
 SERIAL NUMBER 102185

US 380 BLUE ALT AND
 INDEPENDENCE PKWY
 AVERAGE DAILY TRAFFIC
 BLUE ALT BUILD VOLUMES



0135-02-065,
ETC.

SHEET 4 OF 63

DATE: 7/13/2021
FILE: US380_BLUE_TRF_04.dgn



SEE SHEET 4 OF 63

SEE SHEET 6 OF 63

9,300
14,200
16,000

WB US 380 FR

37,700
57,900
66,100

WB US 380 MAINLANES

EB US 380 MAINLANES

37,700
58,000
65,600

EB US 380 FR

8,400
12,800
14,600

ENTRANCE FROM N CUSTER RD (FM 2478)

~~5,900~~ 9900
~~9,000~~ 15100
~~10,300~~ 17300

19200
29300
33300

~~15,200~~
~~23,200~~
~~26,300~~

27800
42800
48800

~~31,800~~
~~48,900~~
~~55,800~~

~~6,400~~ 9700
~~9,900~~ 15000
~~12,100~~ 17800

28000
43000
47800

~~31,300~~
~~48,100~~
~~53,500~~

EXIT TO N CUSTER RD (FM 2478)

18100
27800
32400

~~14,800~~
~~22,700~~
~~26,700~~

NOT TO SCALE

NOT INTENDED FOR CONSTRUCTION,
BIDDING OR PERMIT PURPOSES
DHURVA LAHON, P.E.
SERIAL NUMBER 102185

US 380 BLUE ALT AND
RAMPS
AVERAGE DAILY TRAFFIC
BLUE ALT BUILD VOLUMES

Kimley»Horn
F-928

0135-02-065,
ETC.

SHEET 5 OF 63

LEGEND

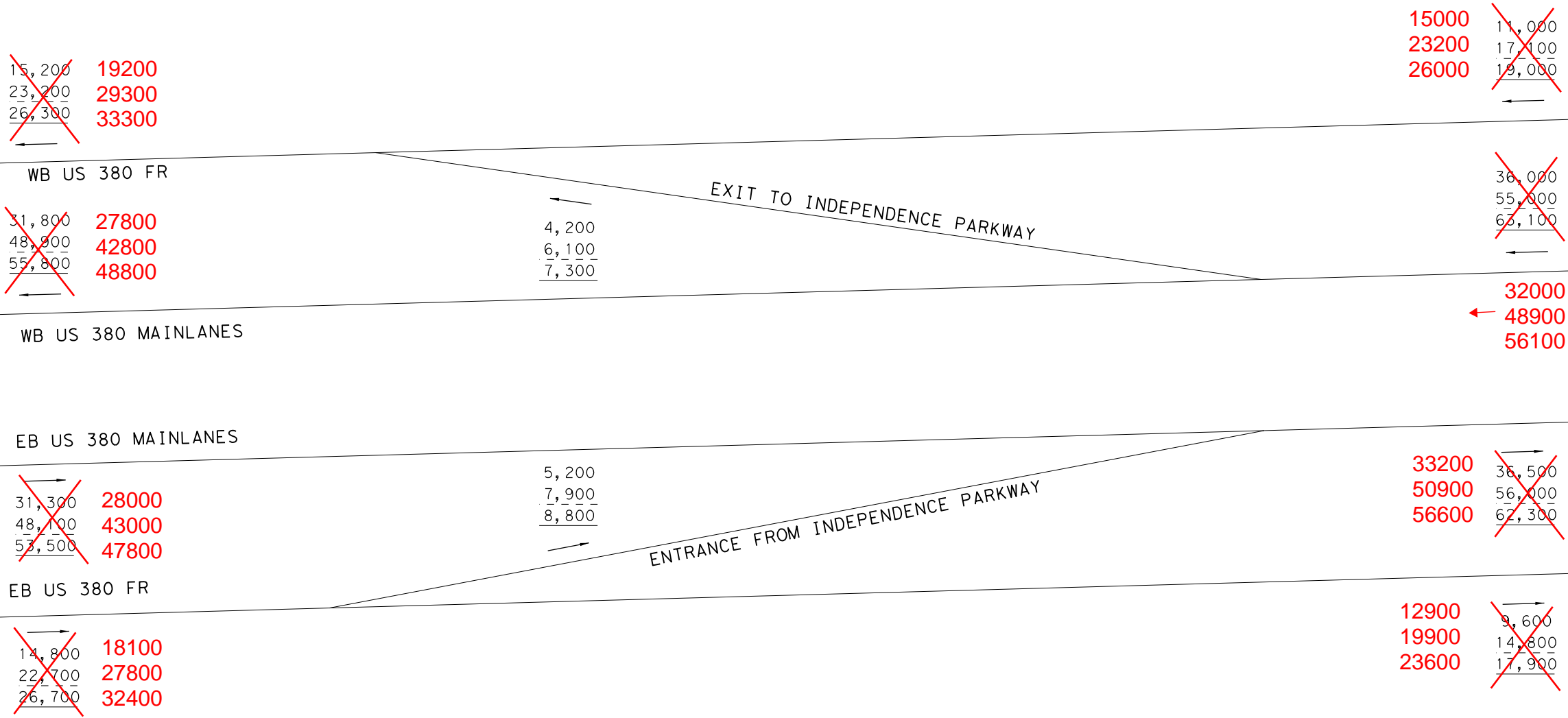
- XXXX- 2030 AVERAGE DAILY TRAFFIC VOLUMES
- XXXX- 2050 AVERAGE DAILY TRAFFIC VOLUMES
- XXXX- 2060 AVERAGE DAILY TRAFFIC VOLUMES

DATE: 7/13/2021
FILE: US380_BLUE_TRF_05.dgn



SEE SHEET 5 OF 63

SEE SHEET 7 OF 63



NOT TO SCALE

NOT INTENDED FOR CONSTRUCTION,
 BIDDING OR PERMIT PURPOSES
 DHRUVA LAHON, P.E.
 SERIAL NUMBER 102185

US 380 BLUE ALT AND
 RAMPS
 AVERAGE DAILY TRAFFIC
 BLUE ALT BUILD VOLUMES



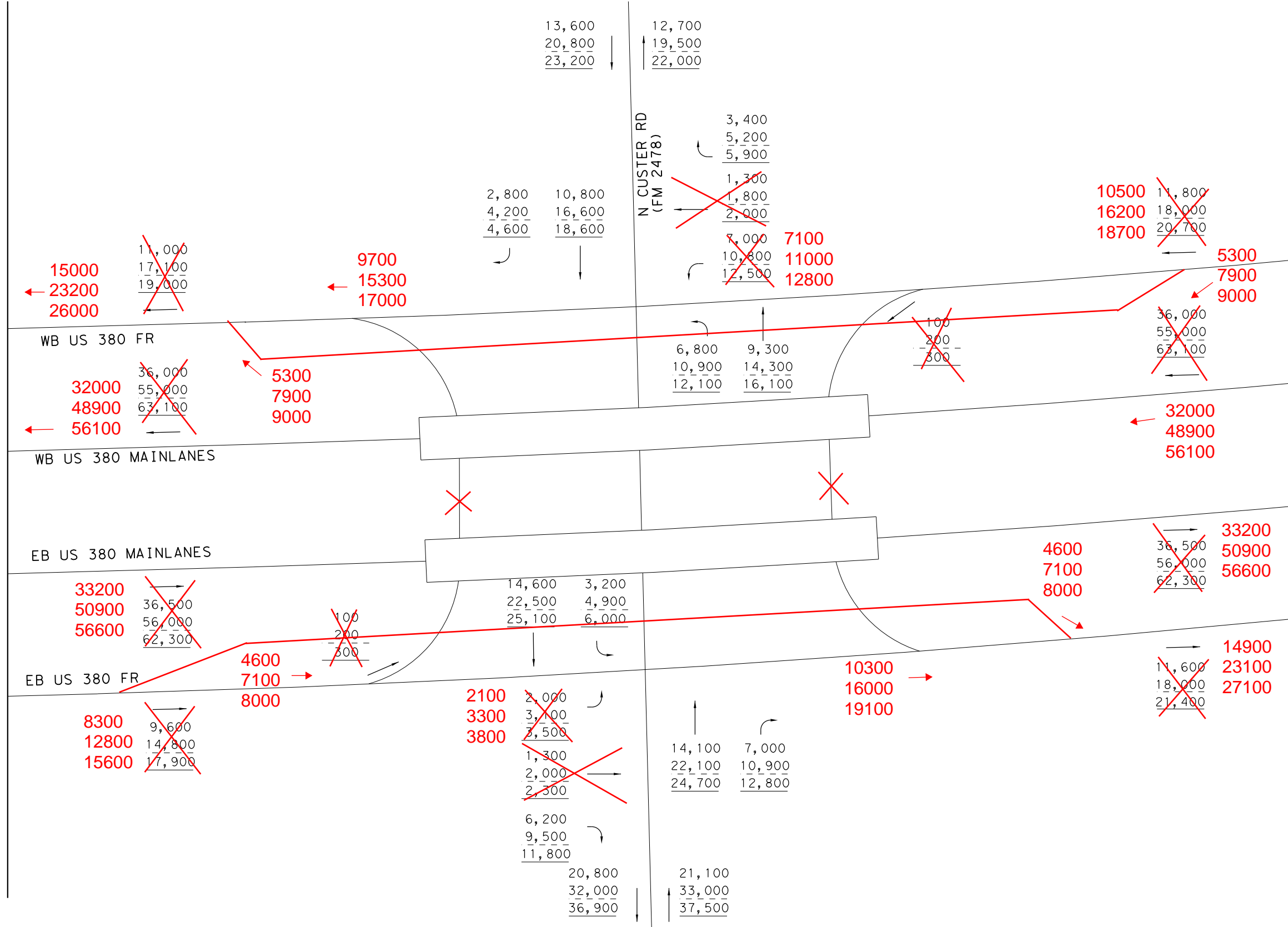
LEGEND

- XXXX- 2030 AVERAGE DAILY TRAFFIC VOLUMES
- XXXX- 2050 AVERAGE DAILY TRAFFIC VOLUMES
- XXXX- 2060 AVERAGE DAILY TRAFFIC VOLUMES



SEE SHEET 6 OF 63

SEE SHEET 8 OF 63



LEGEND

- XXXX- 2030 AVERAGE DAILY TRAFFIC VOLUMES
- XXXX- 2050 AVERAGE DAILY TRAFFIC VOLUMES
- XXXX- 2060 AVERAGE DAILY TRAFFIC VOLUMES

NOT TO SCALE

NOT INTENDED FOR CONSTRUCTION,
 BIDDING OR PERMIT PURPOSES
 DHRUVA LAHON, P.E.
 SERIAL NUMBER 102185

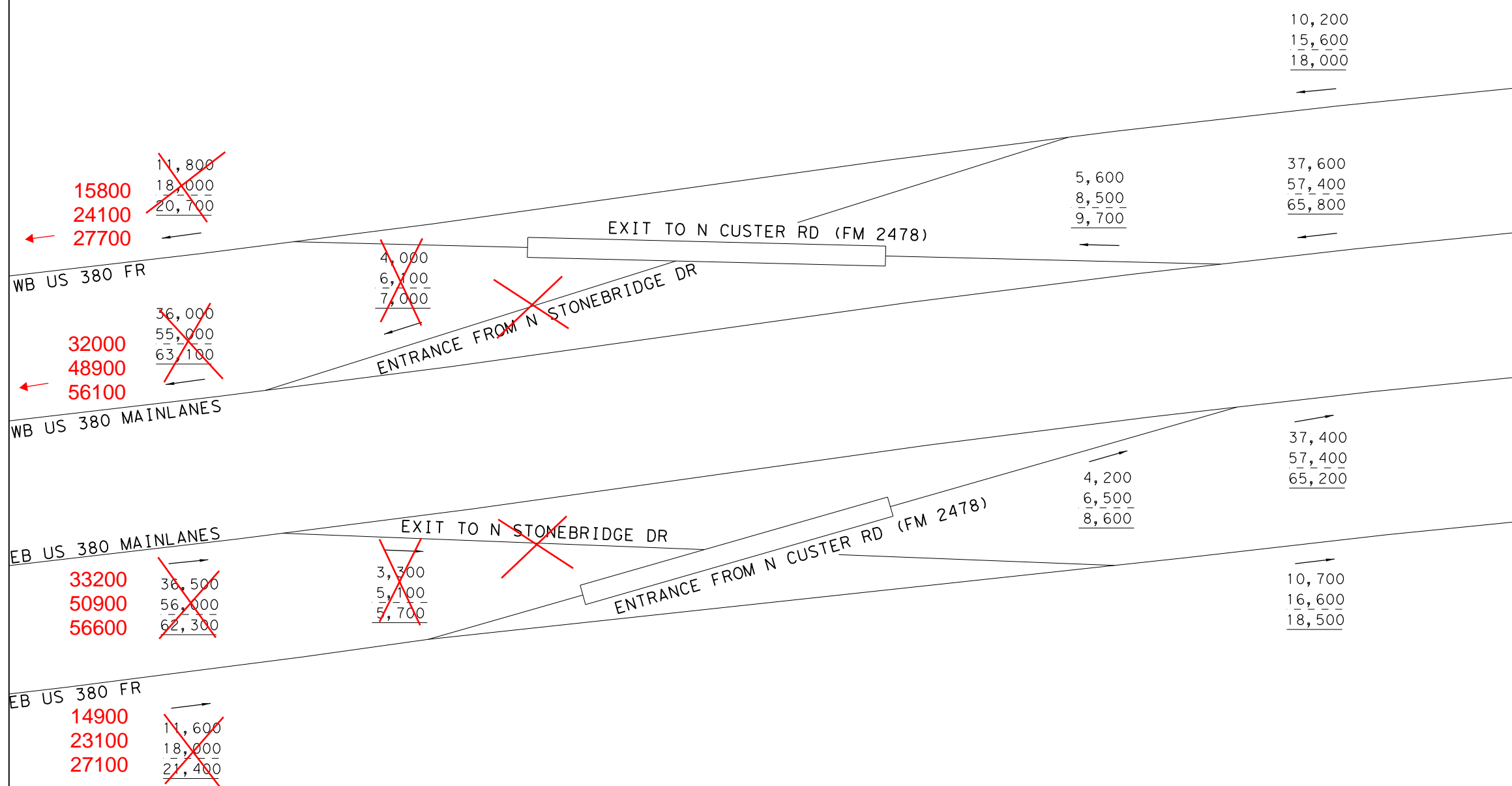
US 380 BLUE ALT AND
 N CUSTER RD
 AVERAGE DAILY TRAFFIC
 BLUE ALT BUILD VOLUMES





SEE SHEET 7 OF 63

SEE SHEET 9 OF 63



NOT TO SCALE

NOT INTENDED FOR CONSTRUCTION,
 BIDDING OR PERMIT PURPOSES
 DHRUVA LAHON, P.E.
 SERIAL NUMBER 102185

US 380 BLUE ALT AND
 RAMPS
 AVERAGE DAILY TRAFFIC
 BLUE ALT BUILD VOLUMES



LEGEND

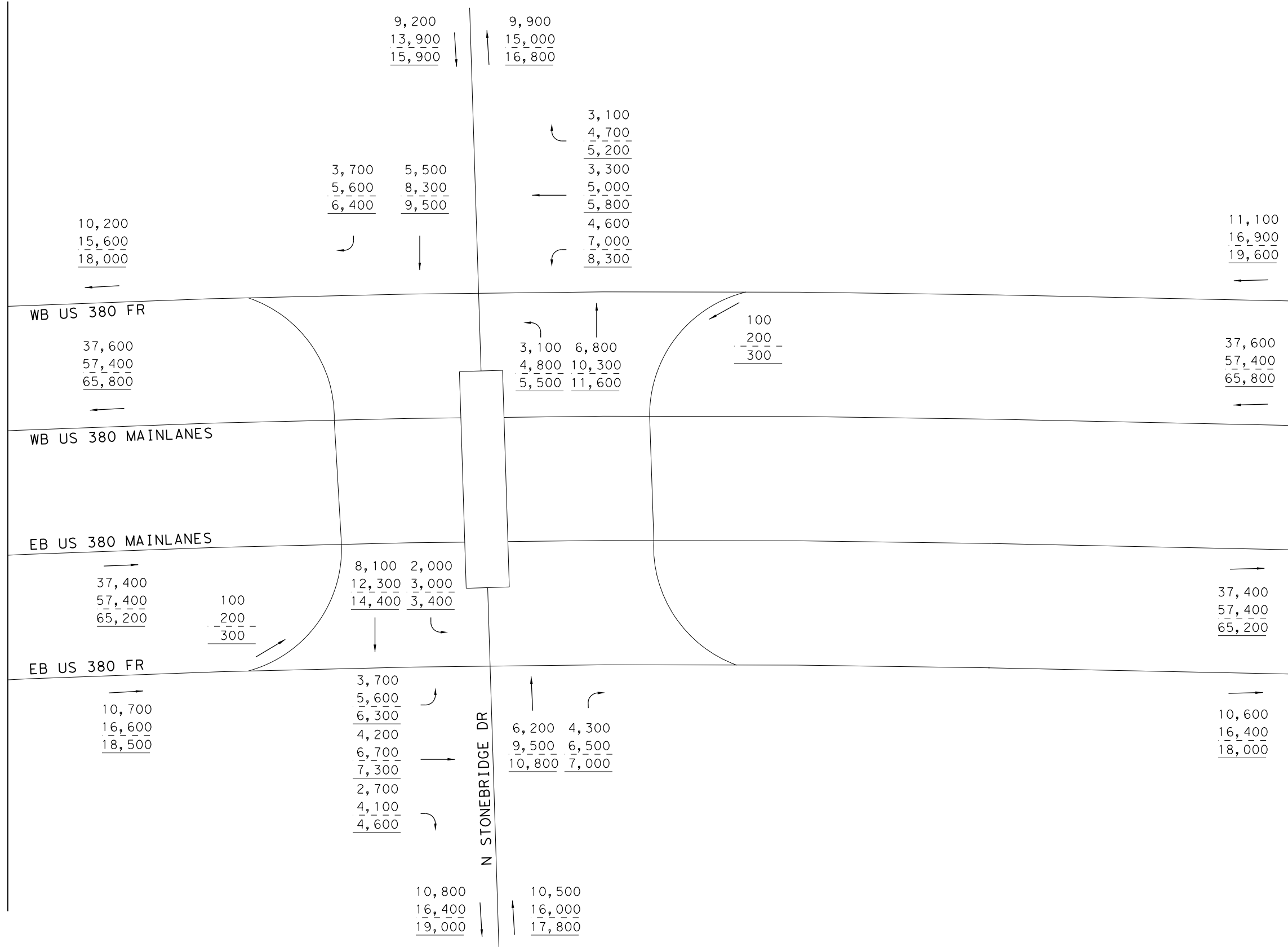
- XXXX- 2030 AVERAGE DAILY TRAFFIC VOLUMES
- XXXX- 2050 AVERAGE DAILY TRAFFIC VOLUMES
- XXXX- 2060 AVERAGE DAILY TRAFFIC VOLUMES

DATE: 7/13/2021
FILE: US380_BLUE_TRF_08.dgn



SEE SHEET 8 OF 63

SEE SHEET 10 OF 63



LEGEND

- XXXX- 2030 AVERAGE DAILY TRAFFIC VOLUMES
- XXXX- 2050 AVERAGE DAILY TRAFFIC VOLUMES
- XXXX- 2060 AVERAGE DAILY TRAFFIC VOLUMES

NOT TO SCALE

NOT INTENDED FOR CONSTRUCTION,
 BIDDING OR PERMIT PURPOSES
 DHRUVA LAHON, P.E.
 SERIAL NUMBER 102185

US 380 BLUE ALT AND
 STONEBRIDGE DR
 AVERAGE DAILY TRAFFIC
 BLUE ALT BUILD VOLUMES



DATE: 7/13/2021
 FILE: US380_BLUE_TRF_09.dgn



SEE SHEET 9 OF 63

SEE SHEET 11 OF 63

11,100
16,900
19,600

WB US 380 FR
37,600
57,400
65,800

WB US 380 MAINLANES

EB US 380 MAINLANES

37,400
57,400
65,200

EB US 380 FR

10,600
16,400
18,000

2,500
3,800
4,900

2,400
3,700
4,000

2,500
3,800
4,900

TREMONT BLVD

2,400
3,700
4,000
8,600
13,100
14,700

11,000
16,800
18,700

NOT TO SCALE

NOT INTENDED FOR CONSTRUCTION,
BIDDING OR PERMIT PURPOSES
DHURVA LAHON, P.E.
SERIAL NUMBER 102185

US 380 BLUE ALT AND
TREMONT BLVD
AVERAGE DAILY TRAFFIC
BLUE ALT BUILD VOLUMES

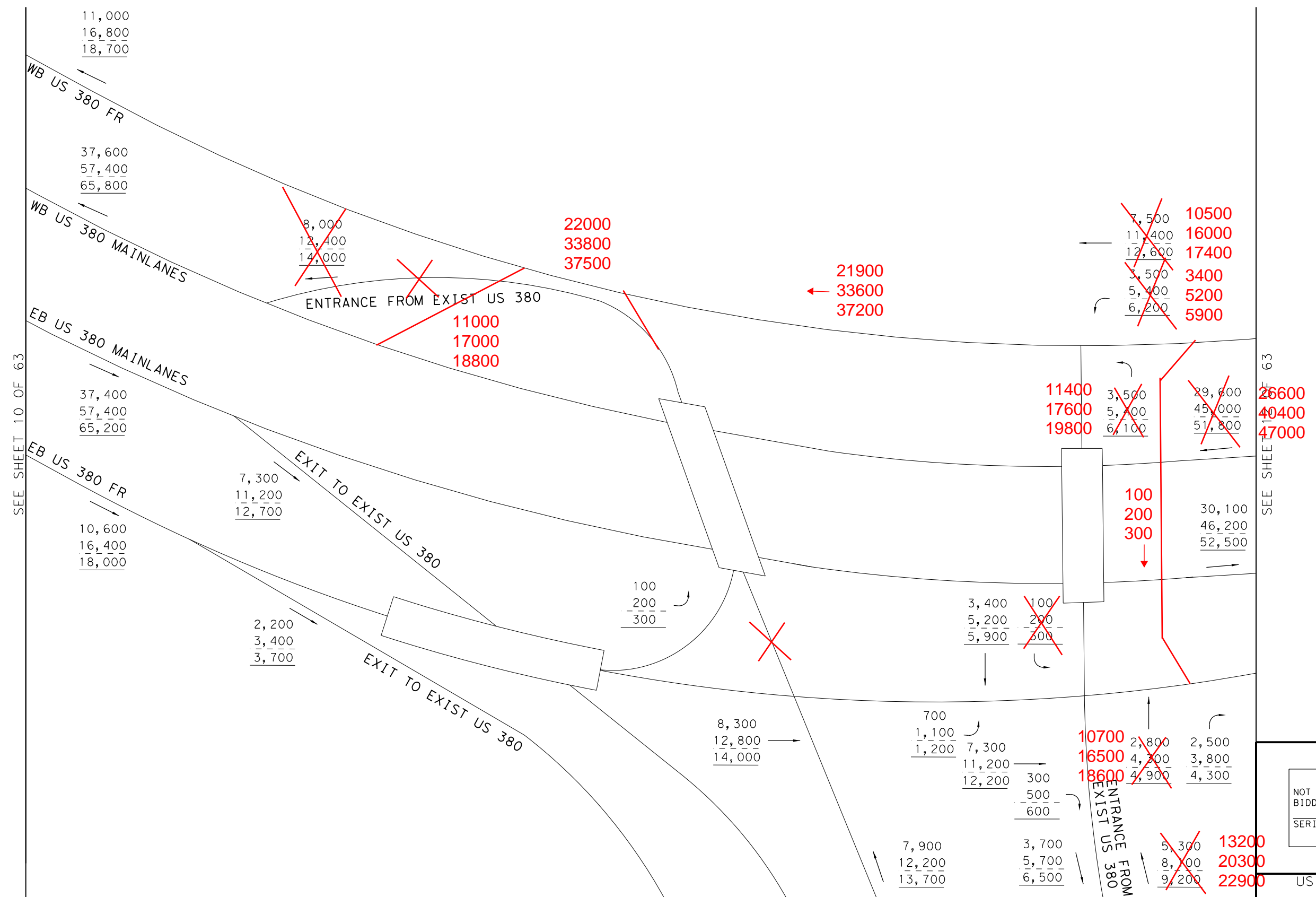
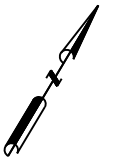
Kimley»Horn
F-928

0135-02-065,
ETC. SHEET 10 OF 63

LEGEND

- XXXX- 2030 AVERAGE DAILY TRAFFIC VOLUMES
- XXXX- 2050 AVERAGE DAILY TRAFFIC VOLUMES
- XXXX- 2060 AVERAGE DAILY TRAFFIC VOLUMES

DATE: 7/13/2021
FILE: US380_BLUE_TRF_10.dgn



SEE SHEET 10 OF 63

SEE SHEET 10 OF 63

SEE SHEET 11A OF 63

NOT TO SCALE

NOT INTENDED FOR CONSTRUCTION,
 BIDDING OR PERMIT PURPOSES
 DHRUVA LAHON, P.E.
 SERIAL NUMBER 102185

US 380 BLUE ALT AND
 RAMP
 AVERAGE DAILY TRAFFIC
 BLUE ALT BUILD VOLUMES

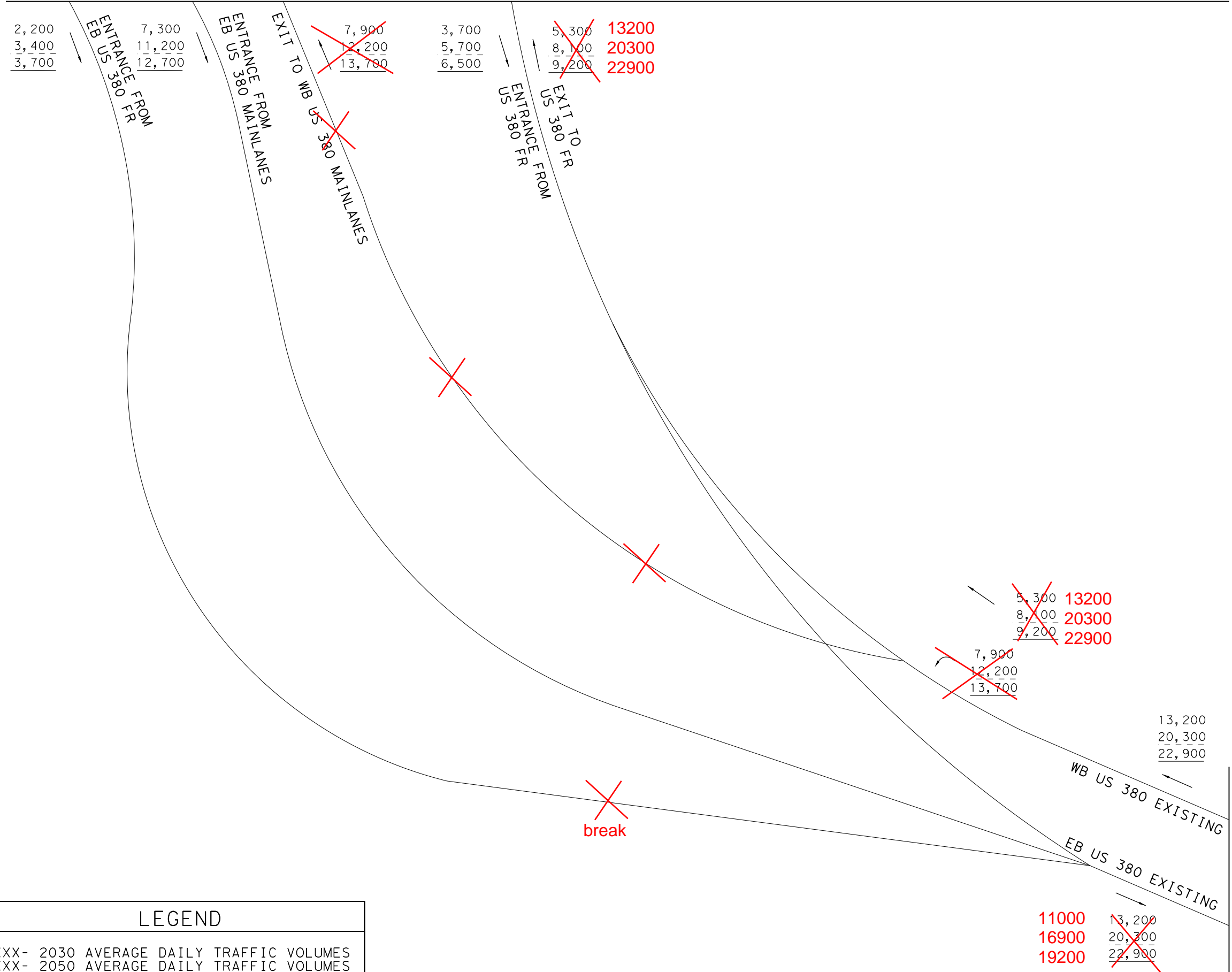
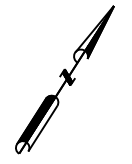
Kimley»Horn
F-928

0135-02-065,
 ETC. SHEET 11 OF 63

LEGEND

- XXXX- 2030 AVERAGE DAILY TRAFFIC VOLUMES
- XXXX- 2050 AVERAGE DAILY TRAFFIC VOLUMES
- XXXX- 2060 AVERAGE DAILY TRAFFIC VOLUMES

DATE: 7/13/2021
 FILE: US380.BLUE.TRF-11.dgn



DATE: 7/13/2021
FILE: US380_BLUE_TRF_11a.dgn

LEGEND	
XXXX-	2030 AVERAGE DAILY TRAFFIC VOLUMES
-XXXX-	2050 AVERAGE DAILY TRAFFIC VOLUMES
<u>XXXX</u>	2060 AVERAGE DAILY TRAFFIC VOLUMES

NOT TO SCALE

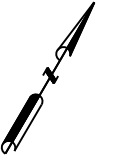
NOT INTENDED FOR CONSTRUCTION, BIDDING OR PERMIT PURPOSES
DHRUVA LAHON, P.E.
SERIAL NUMBER 102185

US 380 BLUE ALT AND EXISTING US 380 AVERAGE DAILY TRAFFIC BLUE ALT BUILD VOLUMES

Kimley»Horn F-928

0135-02-065, ETC. SHEET 11A OF 63

SEE SHEET 47 OF 63



SEE SHEET 11 OF 63

SEE SHEET 13 OF 63

~~11,000~~ 14000
~~16,800~~ 21400
~~18,800~~ 23600

WB US 380 FR

~~29,600~~ 26600
~~45,000~~ 40400
~~51,800~~ 47000

WB US 380 MAINLANES

EB US 380 MAINLANES
30,100
46,200
52,500

EB US 380 FR
9,900
15,200
16,800

ENTRANCE FROM EXIST US 380

EXIT TO EXIST US 380

~~4,200~~
~~6,000~~
~~7,900~~
7200
10600
12700

6,800
10,800
10,900

~~36,400~~
~~55,800~~
~~62,700~~
33400
51200
57900

34,000
52,400
59,300

27300
41900
47600

~~6,000~~
~~9,000~~
~~10,000~~
12700
19500
21700

CR 124 OFR

2800
4300
4900

~~3,900~~
~~6,200~~
~~6,800~~

NOT TO SCALE

NOT INTENDED FOR CONSTRUCTION,
BIDDING OR PERMIT PURPOSES
DHURVA LAHON, P.E.
SERIAL NUMBER 102185

US 380 BLUE ALT AND
RAMPS
AVERAGE DAILY TRAFFIC
BLUE ALT BUILD VOLUMES

Kimley»Horn
F-928

0135-02-065,
ETC. SHEET 12 OF 63

LEGEND

- XXXX- 2030 AVERAGE DAILY TRAFFIC VOLUMES
- XXXX- 2050 AVERAGE DAILY TRAFFIC VOLUMES
- XXXX- 2060 AVERAGE DAILY TRAFFIC VOLUMES

DATE: 7/13/2021
FILE: US380_BLUE_TRF_12.dgn



SEE SHEET 12 OF 63

SEE SHEET 14 OF 63

4,200	7200
6,000	10600
7,900	12700

7,200
10,600
<u>12,700</u>

WB US 380 FR

36,400	33400
55,800	51200
62,700	57900

3,000
4,800
4,800

ENTRANCE FROM CR 124

33,400
51,200
<u>57,900</u>

WB US 380 MAINLANES

EB US 380 MAINLANES

27300	34,000	3900
41900	52,400	6200
47600	59,300	6800

Exist US 380 ONR

2,800
4,800
4,900

EXIT TO CR 124

31,200
48,100
<u>54,400</u>

EB US 380 FR

12700	6,000
19500	9,000
21700	10,000

8,800
13,300
<u>14,900</u>

NOT TO SCALE

NOT INTENDED FOR CONSTRUCTION,
BIDDING OR PERMIT PURPOSES
DHURVA LAHON, P.E.
SERIAL NUMBER 102185

US 380 BLUE ALT AND
RAMPS
AVERAGE DAILY TRAFFIC
BLUE ALT BUILD VOLUMES



0135-02-065,
ETC. SHEET 13 OF 63

LEGEND

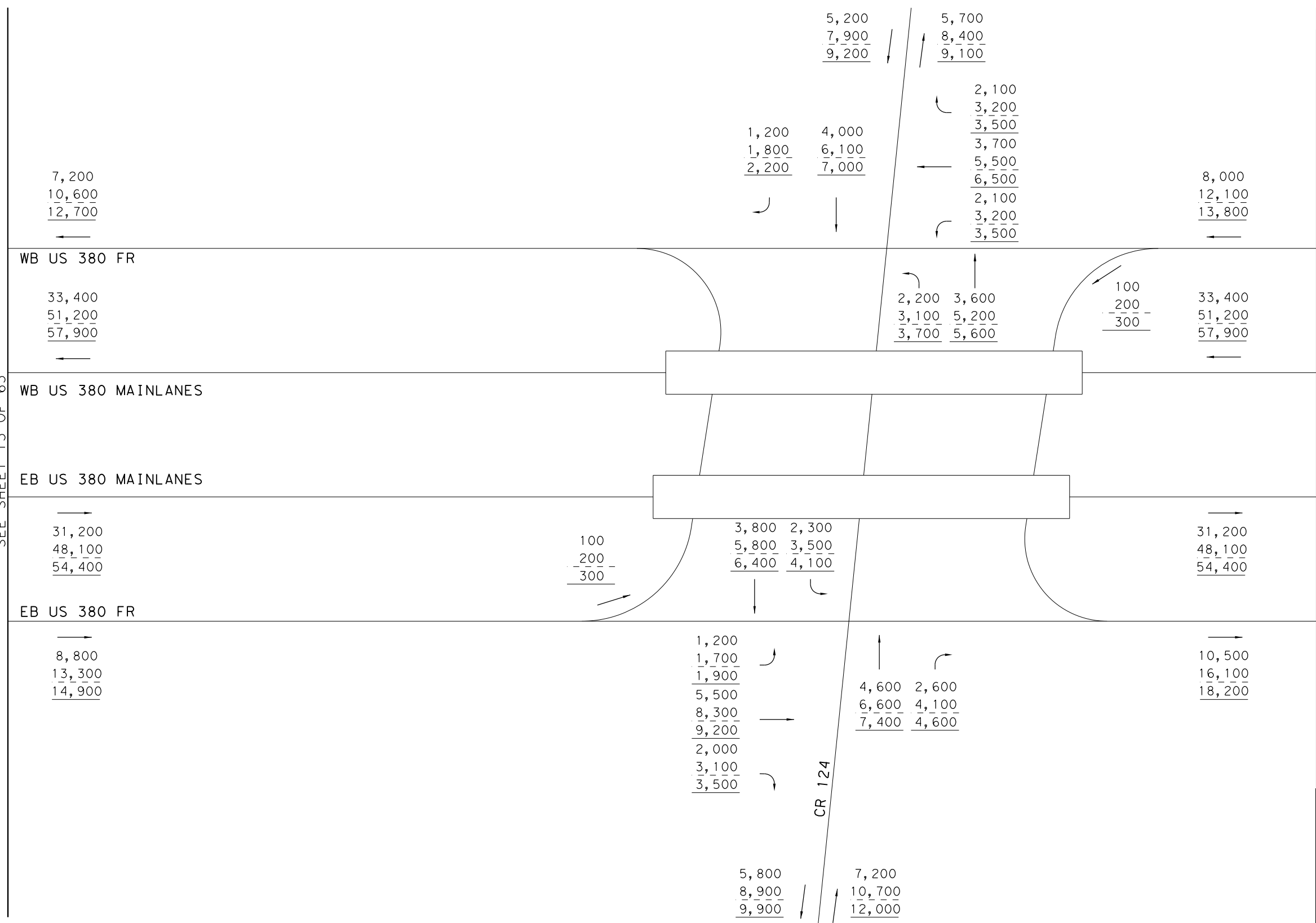
- XXXX- 2030 AVERAGE DAILY TRAFFIC VOLUMES
- XXXX- 2050 AVERAGE DAILY TRAFFIC VOLUMES
- XXXX- 2060 AVERAGE DAILY TRAFFIC VOLUMES

DATE: 7/13/2021
FILE: US380_BLUE_TRF_13.dgn



SEE SHEET 13 OF 63

SEE SHEET 15 OF 63



LEGEND

- XXXX- 2030 AVERAGE DAILY TRAFFIC VOLUMES
- XXXX- 2050 AVERAGE DAILY TRAFFIC VOLUMES
- XXXX- 2060 AVERAGE DAILY TRAFFIC VOLUMES

NOT TO SCALE

NOT INTENDED FOR CONSTRUCTION,
 BIDDING OR PERMIT PURPOSES
 DHRUVA LAHON, P.E.
 SERIAL NUMBER 102185

US 380 BLUE ALT AND
 CR 124
 AVERAGE DAILY TRAFFIC
 BLUE ALT BUILD VOLUMES





SEE SHEET 14 OF 63

SEE SHEET 16 OF 63

8,000
12,100
13,800

12,600
19,200
21,800

WB US 380 FR

4,600
7,100
8,000

ENTRANCE FROM BLOOMDALE RD WEST

28,800
44,100
49,900

WB US 380 MAINLANES

EB US 380 MAINLANES

31,200
48,100
54,400

2,500
3,900
4,400

EXIT TO BLOOMDALE RD WEST

28,700
44,200
50,000

EB US 380 FR

10,500
16,100
18,200

13,000
20,000
22,600

NOT TO SCALE

NOT INTENDED FOR CONSTRUCTION,
BIDDING OR PERMIT PURPOSES
DHURVA LAHON, P.E.
SERIAL NUMBER 102185

US 380 BLUE ALT AND
RAMPS
AVERAGE DAILY TRAFFIC
BLUE ALT BUILD VOLUMES



0135-02-065,
ETC. SHEET 15 OF 63

LEGEND

- XXXX- 2030 AVERAGE DAILY TRAFFIC VOLUMES
- XXXX- 2050 AVERAGE DAILY TRAFFIC VOLUMES
- XXXX- 2060 AVERAGE DAILY TRAFFIC VOLUMES

DATE: 7/13/2021
FILE: US380_BLUE_TRF_15.dgn



SEE SHEET 15 OF 63

SEE SHEET 17 OF 63

12,600
19,200
21,800

WB US 380 FR

28,800
44,100
49,900

WB US 380 MAINLANES

EB US 380 MAINLANES

28,700
44,200
50,000

EB US 380 FR

13,000
20,000
22,600

5,700
8,800
9,900

EXIT TO CR 124

6,500
10,000
11,300

ENTRANCE FROM CR 124

6,900
10,400
11,900

34,500
52,900
59,800

35,200
54,200
61,300

6,500
10,000
11,300

NOT TO SCALE

NOT INTENDED FOR CONSTRUCTION,
BIDDING OR PERMIT PURPOSES
DHURVA LAHON, P.E.
SERIAL NUMBER 102185

US 380 BLUE ALT AND
RAMPS
AVERAGE DAILY TRAFFIC
BLUE ALT BUILD VOLUMES

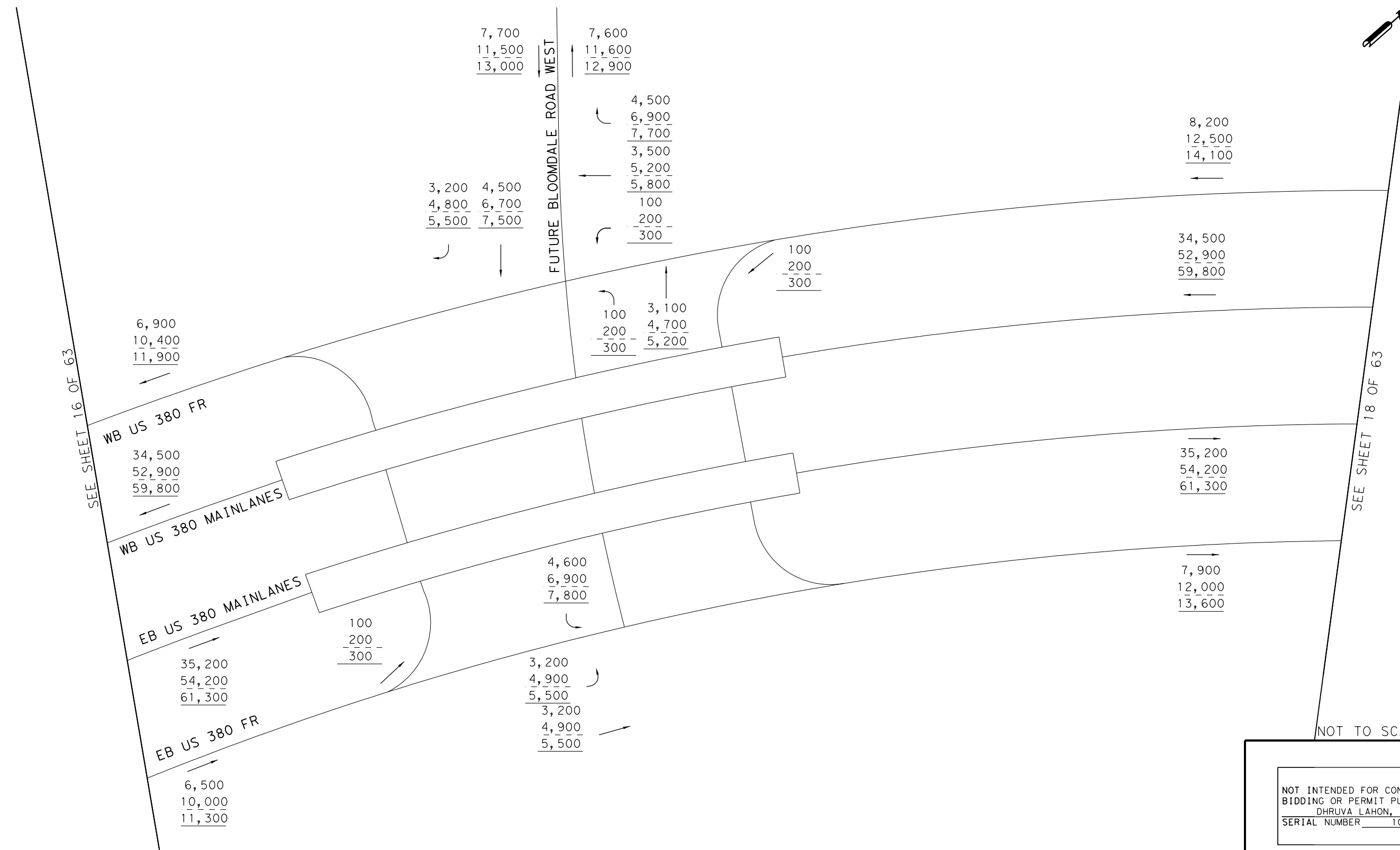
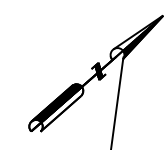
Kimley»Horn
F-928

0135-02-065,
ETC. SHEET 16 OF 63

LEGEND

- XXXX- 2030 AVERAGE DAILY TRAFFIC VOLUMES
- XXXX- 2050 AVERAGE DAILY TRAFFIC VOLUMES
- XXXX- 2060 AVERAGE DAILY TRAFFIC VOLUMES

DATE: 7/13/2021
FILE: US380_BLUE_TRF_16.dgn



SEE SHEET 16 OF 63

SEE SHEET 18 OF 63

NOT TO SCALE

NOT INTENDED FOR CONSTRUCTION,
 BIDDING OR PERMIT PURPOSES
 DHRUVA LAHON, P.E.
 SERIAL NUMBER 102185

US3880 BLUE ALT AND
 W BLOOMDALE RD
 AVERAGE DAILY TRAFFIC
 BLUE ALT BUILD VOLUMES



0135-02-065,
 ETC. SHEET 17 OF 63

LEGEND

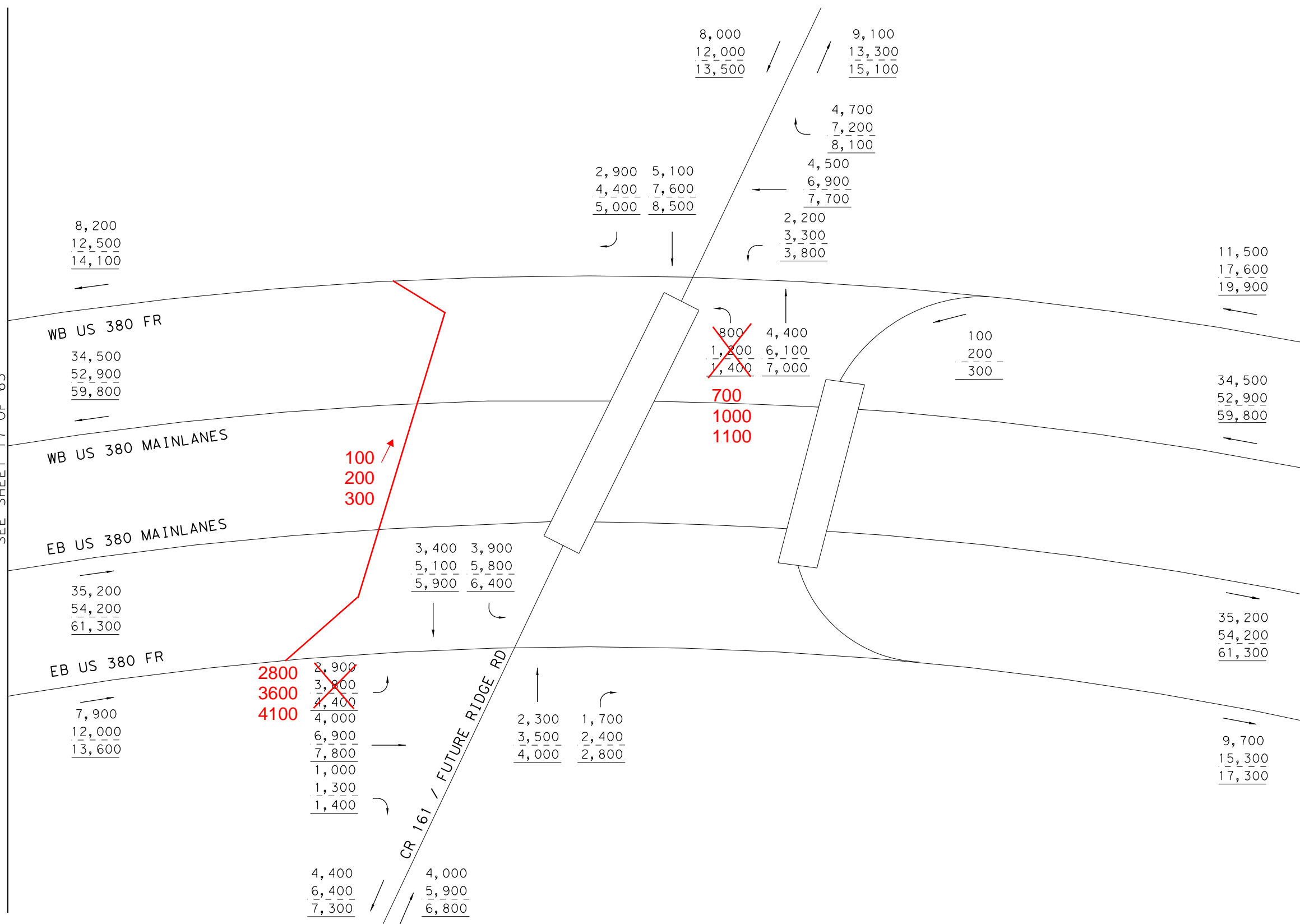
- XXXX- 2030 AVERAGE DAILY TRAFFIC VOLUMES
- XXXX- 2050 AVERAGE DAILY TRAFFIC VOLUMES
- XXXX- 2060 AVERAGE DAILY TRAFFIC VOLUMES

DATE: 7/13/2021
 FILE: US380_BLUE_TRF_17.dgn



SEE SHEET 17 OF 63

SEE SHEET 19 OF 63



LEGEND

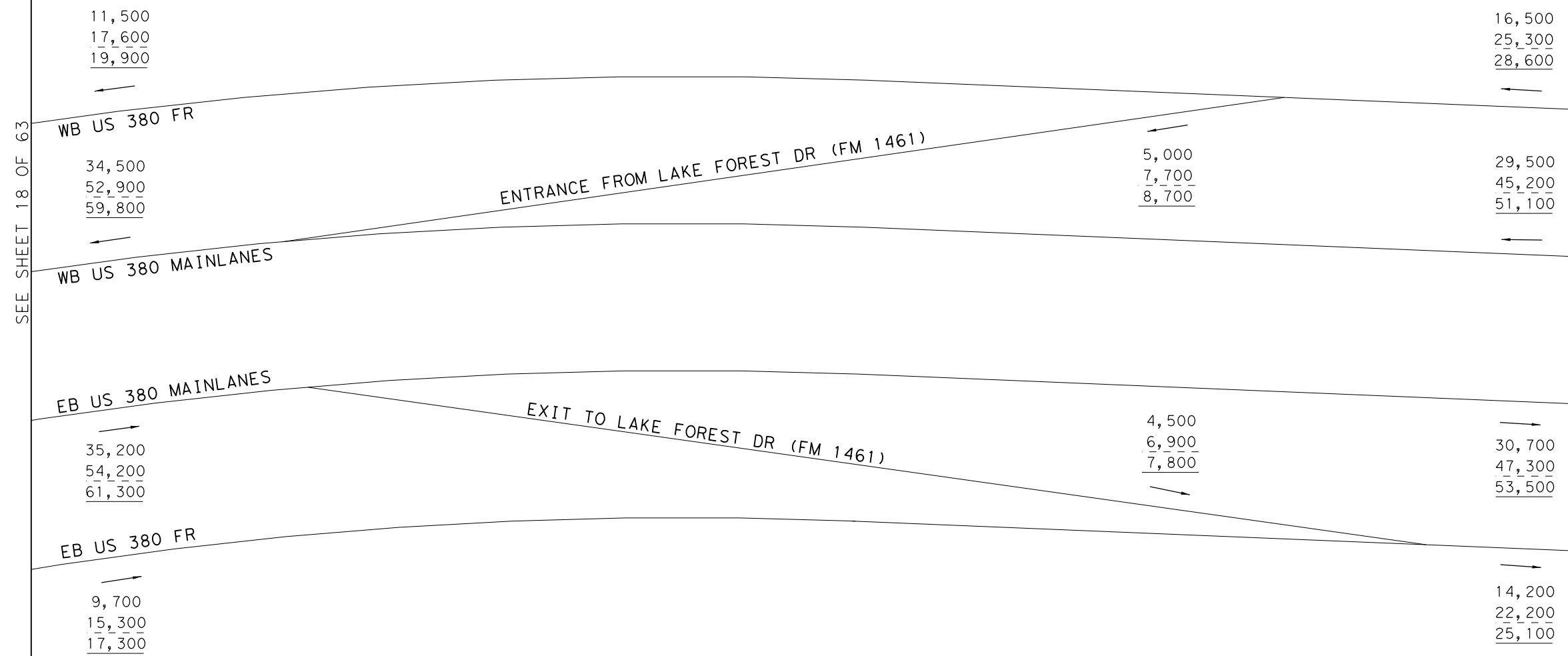
- XXXX- 2030 AVERAGE DAILY TRAFFIC VOLUMES
- XXXX- 2050 AVERAGE DAILY TRAFFIC VOLUMES
- XXXX- 2060 AVERAGE DAILY TRAFFIC VOLUMES

NOT TO SCALE

NOT INTENDED FOR CONSTRUCTION,
 BIDDING OR PERMIT PURPOSES
 DHRUVA LAHON, P.E.
 SERIAL NUMBER 102185

US 380 BLUE ALT AND
 CR 161/FUTURE RIDGE RD
 AVERAGE DAILY TRAFFIC
 BLUE ALT BUILD VOLUMES





SEE SHEET 18 OF 63

SEE SHEET 20 OF 63

NOT TO SCALE

NOT INTENDED FOR CONSTRUCTION,
 BIDDING OR PERMIT PURPOSES
 DHRUVA LAHON, P.E.
 SERIAL NUMBER 102185

US 380 BLUE ALT AND
 RAMPS
 AVERAGE DAILY TRAFFIC
 BLUE ALT BUILD VOLUMES



0135-02-065,
 ETC. SHEET 19 OF 63

LEGEND

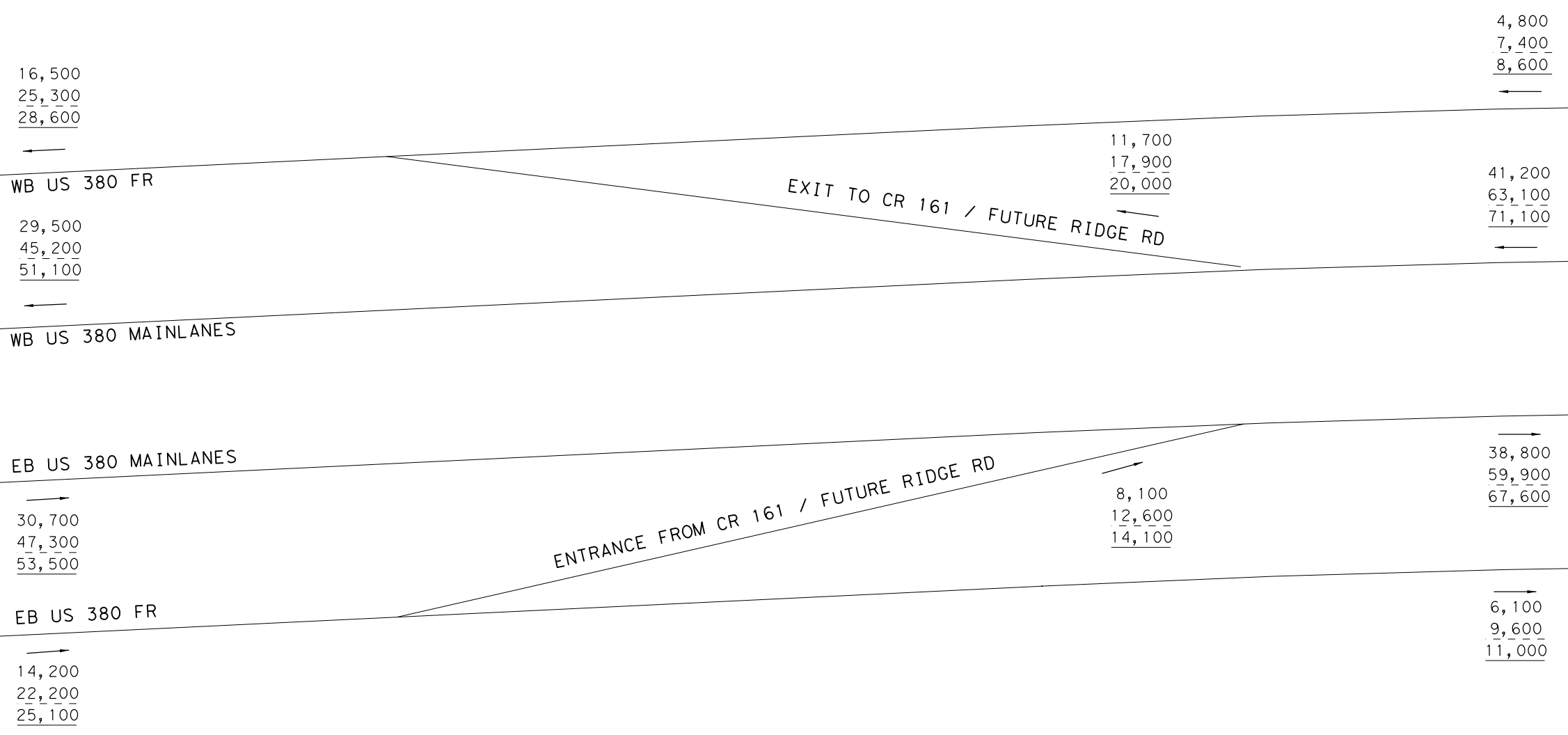
- XXXX- 2030 AVERAGE DAILY TRAFFIC VOLUMES
- XXXX- 2050 AVERAGE DAILY TRAFFIC VOLUMES
- XXXX- 2060 AVERAGE DAILY TRAFFIC VOLUMES

DATE: 7/13/2021
 FILE: US380_BLUE_TRF_19.dgn



SEE SHEET 19 OF 63

SEE SHEET 21 OF 63



LEGEND

- XXXX- 2030 AVERAGE DAILY TRAFFIC VOLUMES
- XXXX- 2050 AVERAGE DAILY TRAFFIC VOLUMES
- XXXX- 2060 AVERAGE DAILY TRAFFIC VOLUMES

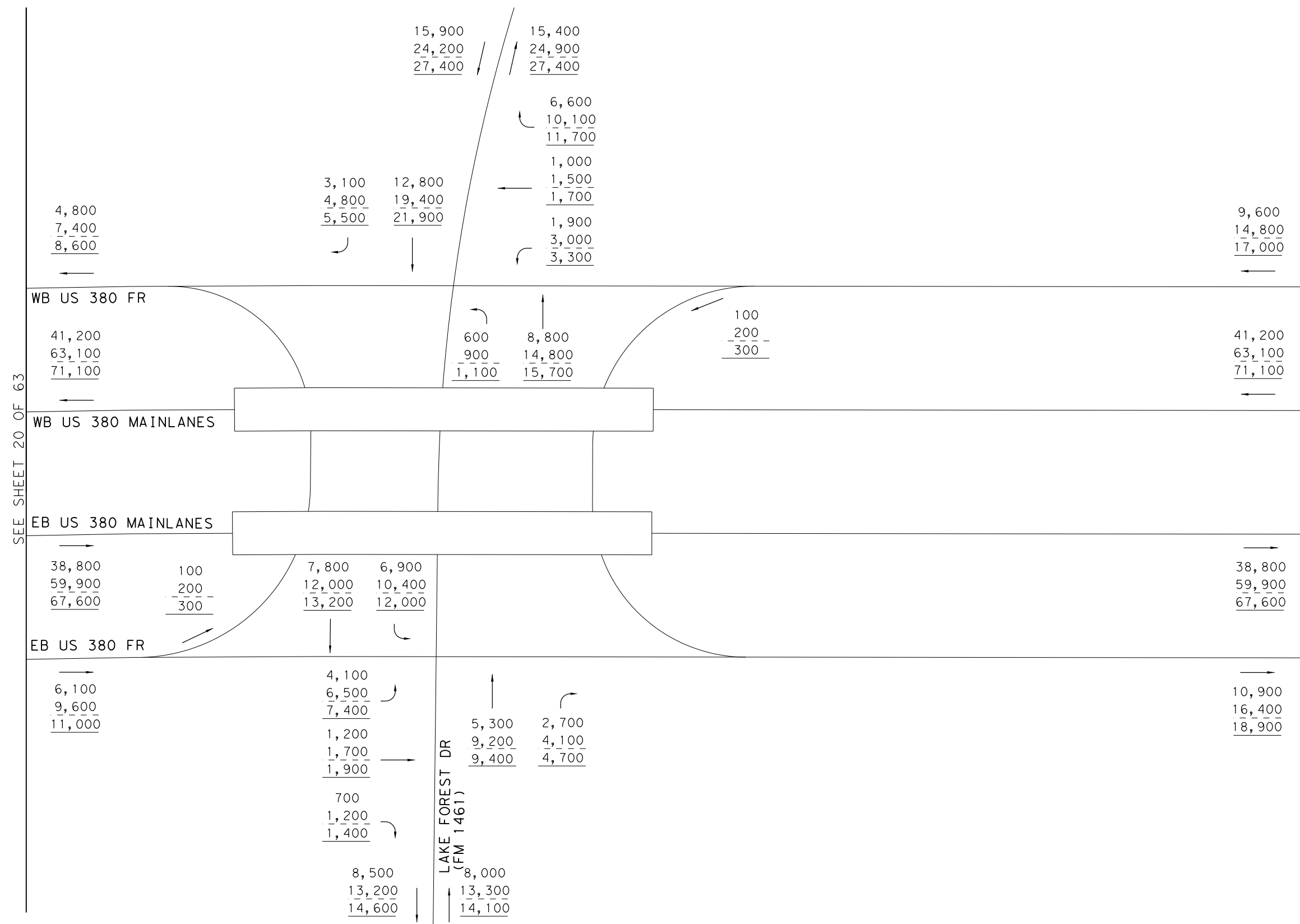
NOT TO SCALE

NOT INTENDED FOR CONSTRUCTION,
 BIDDING OR PERMIT PURPOSES
 DHRUVA LAHON, P.E.
 SERIAL NUMBER 102185

US 380 BLUE ALT AND
 RAMPS
 AVERAGE DAILY TRAFFIC
 BLUE ALT BUILD VOLUMES



DATE: 7/13/2021
 FILE: US380_BLUE_TRF_20.dgn



SEE SHEET 20 OF 63

SEE SHEET 22 OF 63

NOT TO SCALE

NOT INTENDED FOR CONSTRUCTION,
 BIDDING OR PERMIT PURPOSES
 DHRUVA LAHON, P.E.
 SERIAL NUMBER 102185

US 380 BLUE ALT AND
 LAKE FOREST DR
 AVERAGE DAILY TRAFFIC
 BLUE ALT BUILD VOLUMES



LEGEND

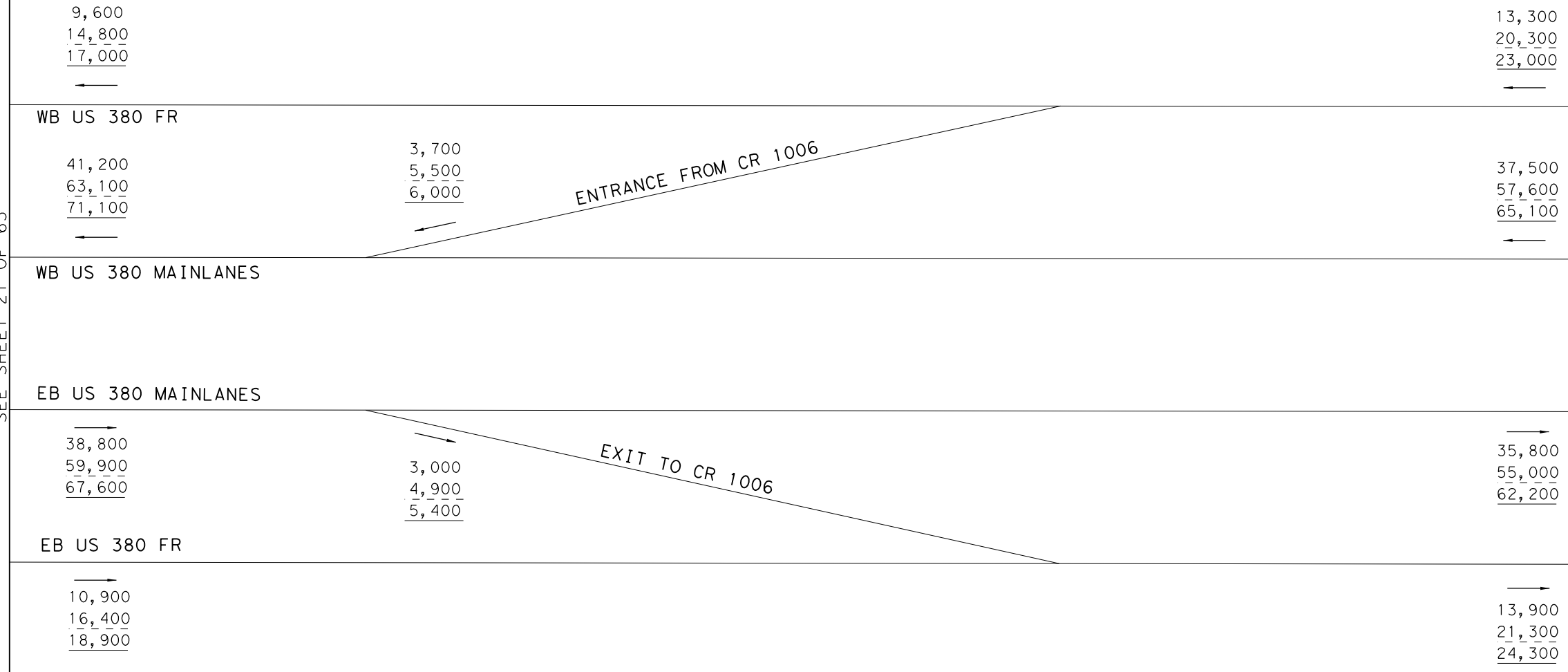
- XXXX- 2030 AVERAGE DAILY TRAFFIC VOLUMES
- XXXX- 2050 AVERAGE DAILY TRAFFIC VOLUMES
- XXXX- 2060 AVERAGE DAILY TRAFFIC VOLUMES

DATE: 7/13/2021
 FILE: US380_BLUE_TRF_21.dgn



SEE SHEET 21 OF 63

SEE SHEET 23 OF 63



NOT TO SCALE

NOT INTENDED FOR CONSTRUCTION,
 BIDDING OR PERMIT PURPOSES
 DHRUVA LAHON, P.E.
 SERIAL NUMBER 102185

US 380 BLUE ALT AND
 RAMPS
 AVERAGE DAILY TRAFFIC
 BLUE ALT BUILD VOLUMES



0135-02-065,
 ETC. SHEET 22 OF 63

LEGEND

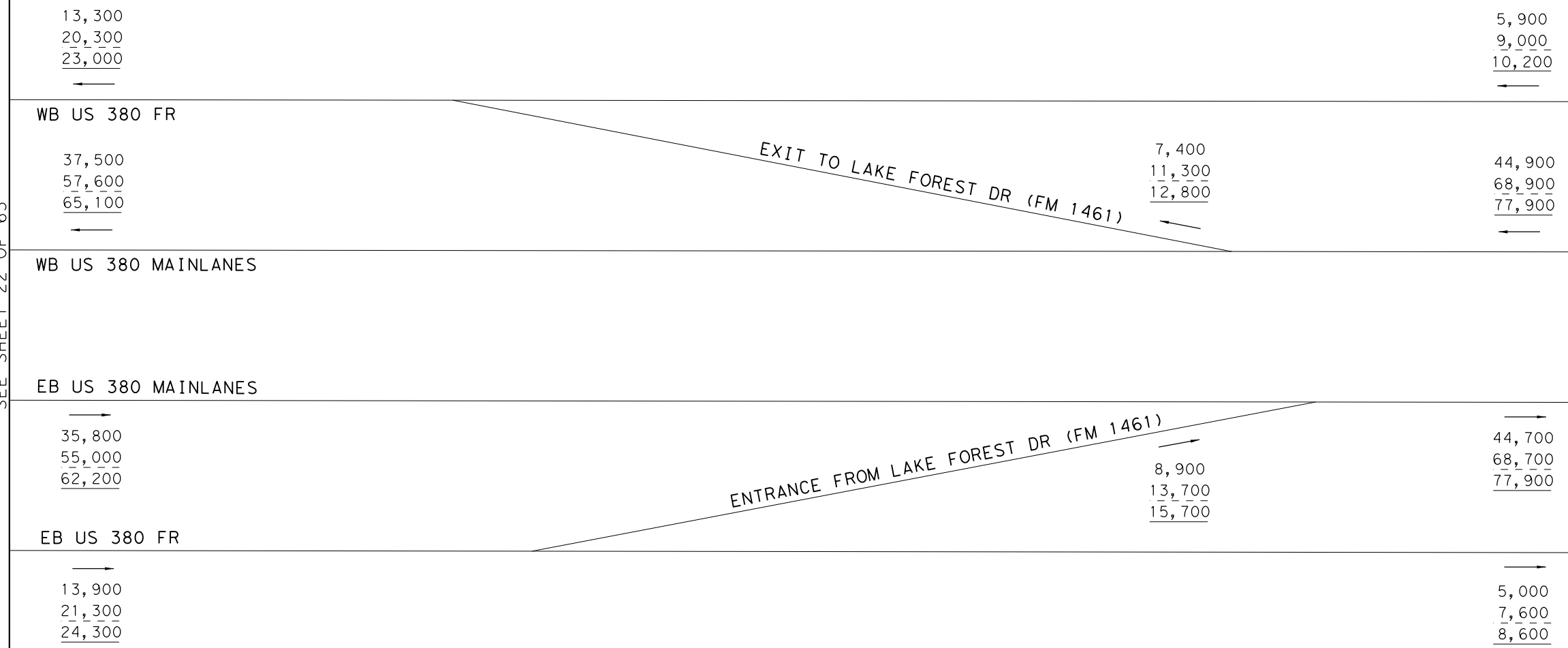
- XXXX- 2030 AVERAGE DAILY TRAFFIC VOLUMES
- XXXX- 2050 AVERAGE DAILY TRAFFIC VOLUMES
- XXXX- 2060 AVERAGE DAILY TRAFFIC VOLUMES

DATE: 7/13/2021
 FILE: US380_BLUE_TRF_22.dgn



SEE SHEET 22 OF 63

SEE SHEET 24 OF 63



NOT TO SCALE

NOT INTENDED FOR CONSTRUCTION,
 BIDDING OR PERMIT PURPOSES
 DHRUVA LAHON, P.E.
 SERIAL NUMBER 102185

US 380 BLUE ALT AND
 RAMPS
 AVERAGE DAILY TRAFFIC
 BLUE ALT BUILD VOLUMES



0135-02-065,
 ETC. SHEET 23 OF 63

LEGEND

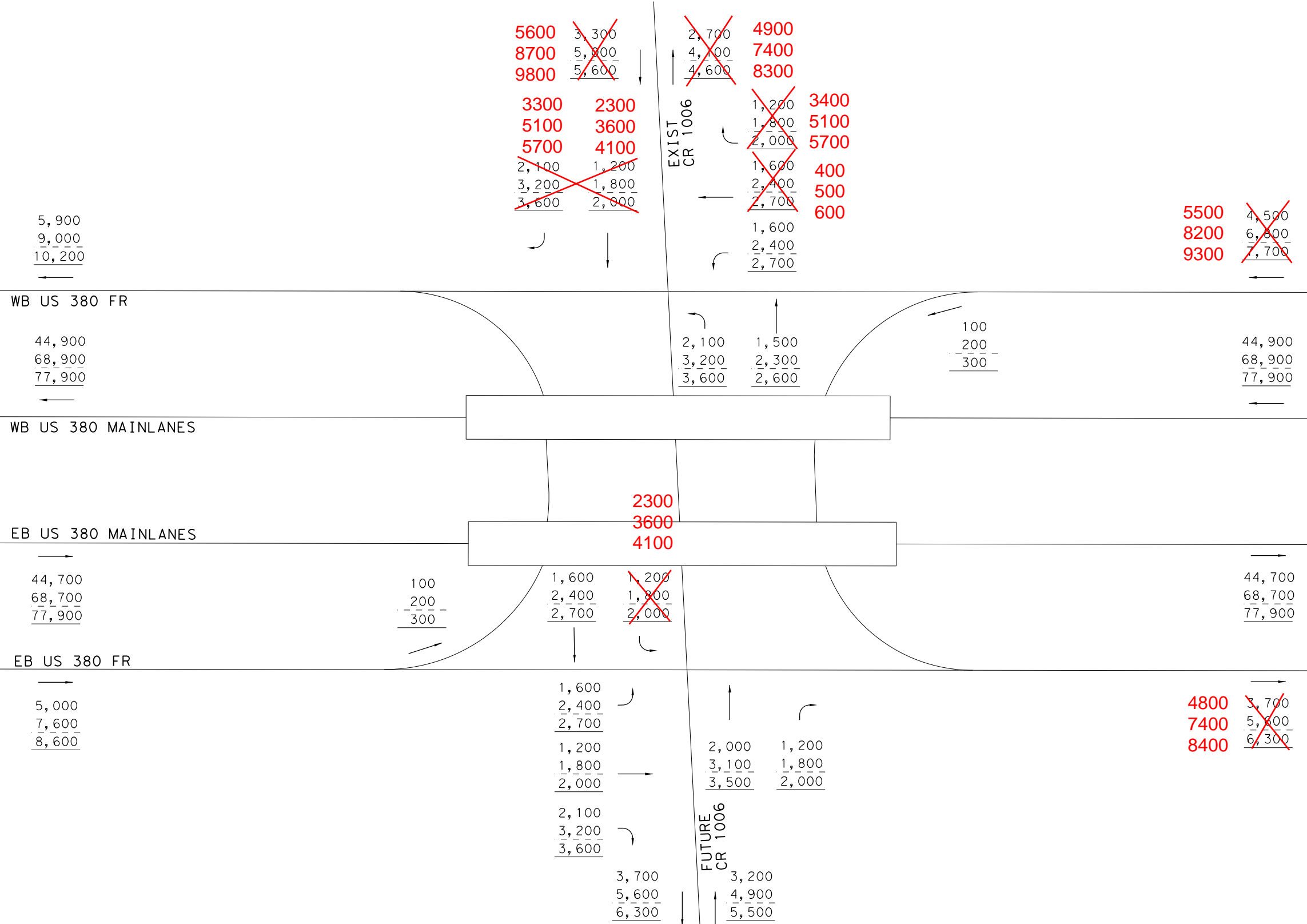
- XXXX- 2030 AVERAGE DAILY TRAFFIC VOLUMES
- XXXX- 2050 AVERAGE DAILY TRAFFIC VOLUMES
- XXXX- 2060 AVERAGE DAILY TRAFFIC VOLUMES

DATE: 7/13/2021
 FILE: US380_BLUE_TRF_23.dgn



SEE SHEET 23 OF 63

SEE SHEET 25 OF 63



LEGEND

- XXXX- 2030 AVERAGE DAILY TRAFFIC VOLUMES
- XXXX- 2050 AVERAGE DAILY TRAFFIC VOLUMES
- XXXX- 2060 AVERAGE DAILY TRAFFIC VOLUMES

NOT TO SCALE

NOT INTENDED FOR CONSTRUCTION,
 BIDDING OR PERMIT PURPOSES
 DHRUVA LAHON, P.E.
 SERIAL NUMBER 102185

US 380 BLUE ALT AND
 CR 1006
 AVERAGE DAILY TRAFFIC
 BLUE ALT BUILD VOLUMES



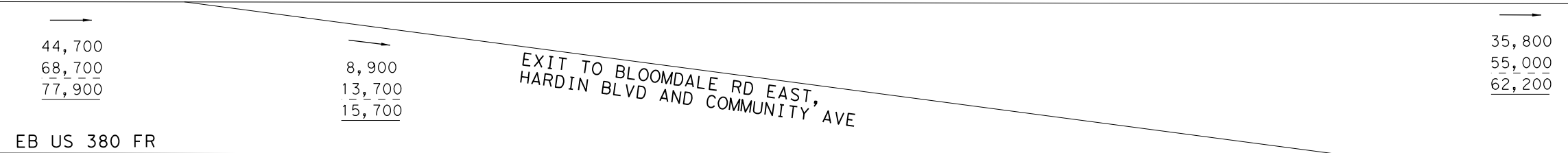
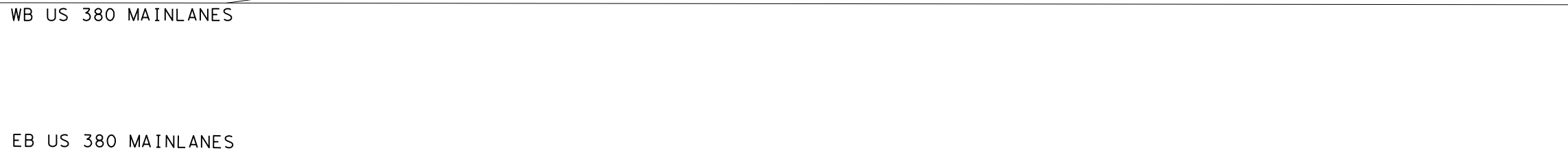
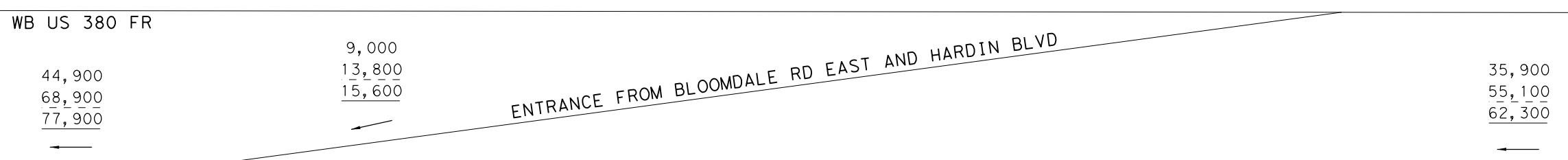


SEE SHEET 24 OF 63

SEE SHEET 26 OF 63

4,500	5500
6,800	8200
7,700	9300

14500	13,500
22000	20,600
24900	28,300



NOT TO SCALE

NOT INTENDED FOR CONSTRUCTION,
 BIDDING OR PERMIT PURPOSES
 DHRUVA LAHON, P.E.
 SERIAL NUMBER 102185

US 380 BLUE ALT AND
 RAMPS
 AVERAGE DAILY TRAFFIC
 BLUE ALT BUILD VOLUMES



0135-02-065,
 ETC. SHEET 25 OF 63

LEGEND

- XXXX- 2030 AVERAGE DAILY TRAFFIC VOLUMES
- XXXX- 2050 AVERAGE DAILY TRAFFIC VOLUMES
- XXXX- 2060 AVERAGE DAILY TRAFFIC VOLUMES

DATE: 7/13/2021
FILE: US380_BLUE_TRF_25.dgn



13,500	14500
20,600	22000
23,300	24900

12200	11,200
18600	17,800
21200	19,600

WB US 380 FR

35,900
<u>55,100</u>
62,300

2,300
<u>3,400</u>
3,700

38,200
<u>58,500</u>
66,000

WB US 380 MAINLANES

EXIT TO CR 1006

EB US 380 MAINLANES

35,800
<u>55,000</u>
62,200

2,000
<u>2,800</u>
3,100

37,800
<u>57,800</u>
65,300

EB US 380 FR

ENTRANCE FROM CR 1006

12,600	13700
19,300	21100
22,000	24100

11700	10,600
18300	16,500
21000	18,900

SEE SHEET 25 OF 63

SEE SHEET 27 OF 63

NOT TO SCALE

NOT INTENDED FOR CONSTRUCTION,
BIDDING OR PERMIT PURPOSES
DHURVA LAHON, P.E.
SERIAL NUMBER 102185

US 380 BLUE ALT AND
RAMPS
AVERAGE DAILY TRAFFIC
BLUE ALT BUILD VOLUMES

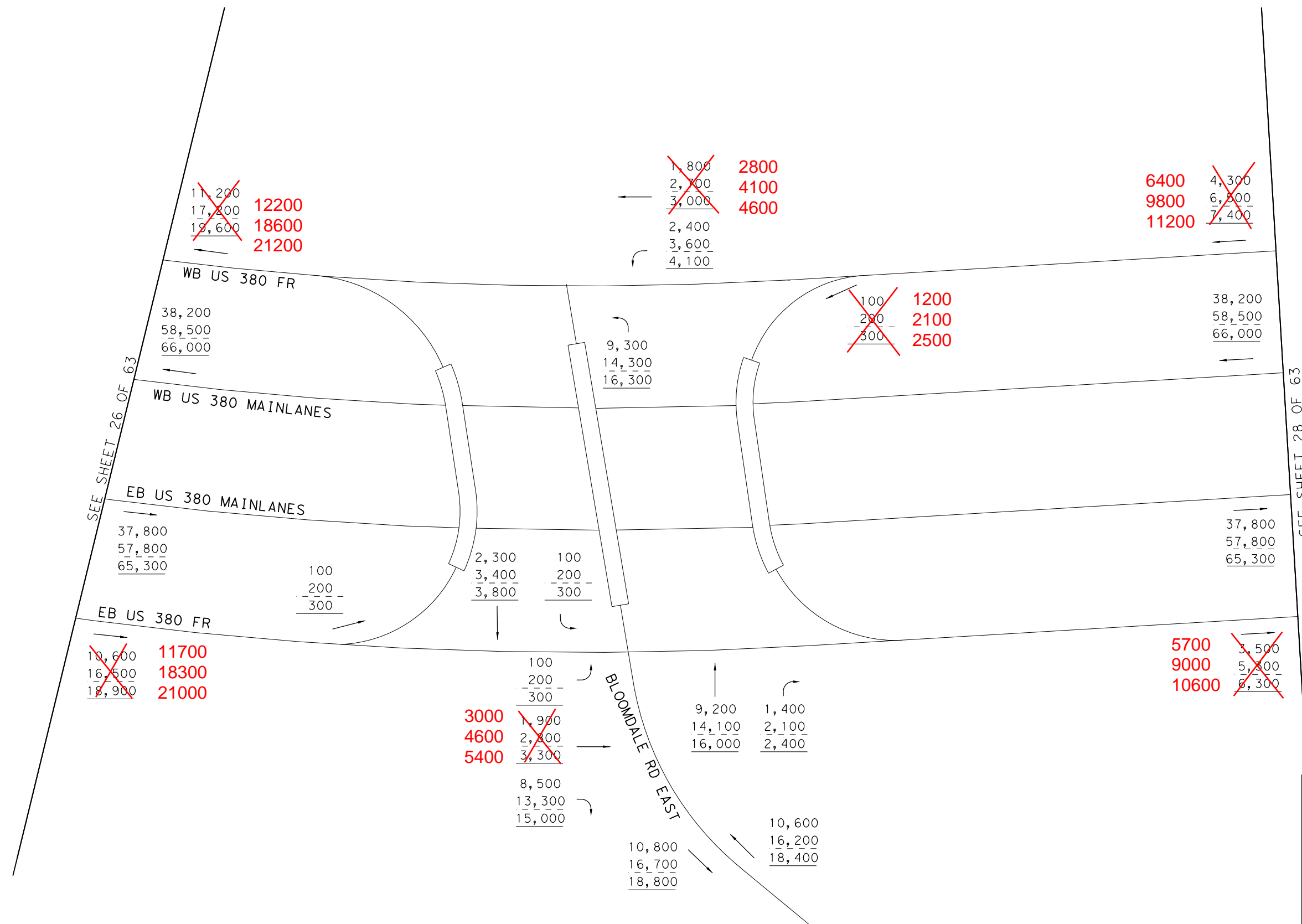
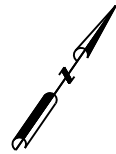
Kimley»Horn
F-928

0135-02-065,
ETC.

SHEET 26 OF 63

LEGEND

- XXXX- 2030 AVERAGE DAILY TRAFFIC VOLUMES
- XXXX- 2050 AVERAGE DAILY TRAFFIC VOLUMES
- XXXX- 2060 AVERAGE DAILY TRAFFIC VOLUMES



SEE SHEET 26 OF 63

SEE SHEET 28 OF 63

NOT TO SCALE

NOT INTENDED FOR CONSTRUCTION,
 BIDDING OR PERMIT PURPOSES
 DHRUVA LAHON, P.E.
 SERIAL NUMBER 102185

US 380 BLUE ALT AND
 E BLOOMDALE RD
 AVERAGE DAILY TRAFFIC
 BLUE ALT BUILD VOLUMES

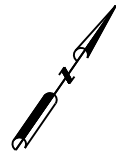
Kimley»Horn
F-928

0135-02-065,
 ETC. SHEET 27 OF 63

LEGEND

- XXXX- 2030 AVERAGE DAILY TRAFFIC VOLUMES
- XXXX- 2050 AVERAGE DAILY TRAFFIC VOLUMES
- XXXX- 2060 AVERAGE DAILY TRAFFIC VOLUMES

DATE: 7/13/2021
 FILE: US380_BLUE_TRF_27.dgn



RD 201

2400
3700
4200
↓

2200
3300
3800
↑

2400
3700
4200
↓

2200
3300
3800
4000
6100
7000

~~4,300~~
~~6,500~~
~~7,400~~

~~4,300~~
~~6,500~~
~~7,400~~

6400
9800
11200

WB US 380 FR

38,200
58,500
66,000

38,200
58,500
66,000

WB US 380 MAINLANES

EB US 380 MAINLANES

37,800
57,800
65,300

37,800
57,800
65,300

EB US 380 FR

~~3,500~~
~~5,700~~
~~6,300~~

5700
9000
10600

5700
9000
10600

~~3,500~~
~~5,700~~
~~6,300~~

SEE SHEET 27 OF 63

SEE SHEET 29 OF 63

NOT TO SCALE

NOT INTENDED FOR CONSTRUCTION,
BIDDING OR PERMIT PURPOSES
DHURVA LAHON, P.E.
SERIAL NUMBER 102185

US 380 BLUE ALT

AVERAGE DAILY TRAFFIC
BLUE ALT BUILD VOLUMES

Kimley»Horn
F-928

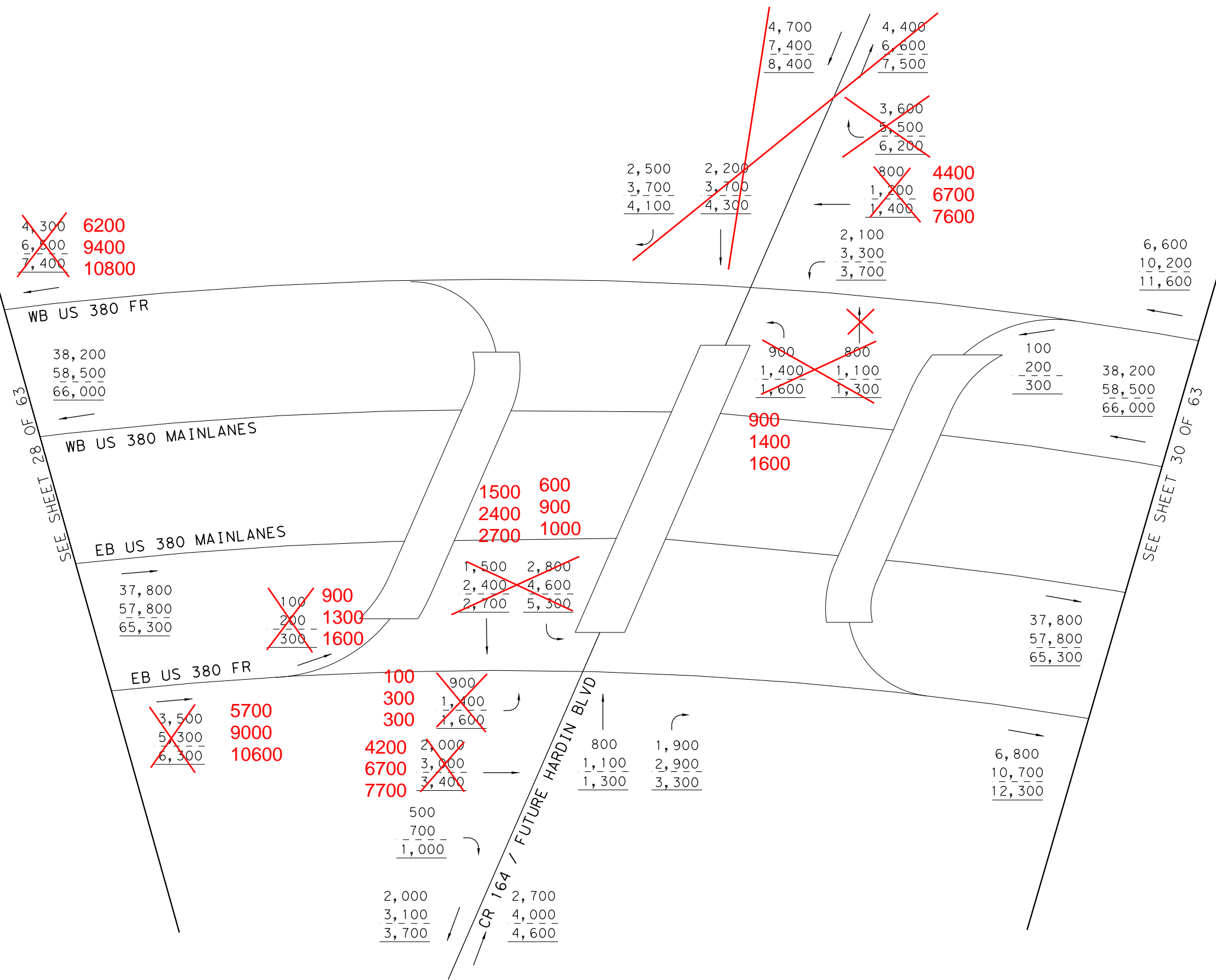
0135-02-065,
ETC.

SHEET 28 OF 63

LEGEND

- XXXX- 2030 AVERAGE DAILY TRAFFIC VOLUMES
- XXXX- 2050 AVERAGE DAILY TRAFFIC VOLUMES
- XXXX- 2060 AVERAGE DAILY TRAFFIC VOLUMES

DATE: 7/13/2021
FILE: US380_BLUE_TRF_28.dgn



SEE SHEET 28 OF 63

SEE SHEET 30 OF 63

WB US 380 FR

WB US 380 MAINLANES

EB US 380 MAINLANES

EB US 380 FR

CR 164 / FUTURE HARDIN BLVD

LEGEND	
XXXX-	2030 AVERAGE DAILY TRAFFIC VOLUMES
-XXXX-	2050 AVERAGE DAILY TRAFFIC VOLUMES
XXXX-	2060 AVERAGE DAILY TRAFFIC VOLUMES

NOT TO SCALE

NOT INTENDED FOR CONSTRUCTION,
 BIDDING OR PERMIT PURPOSES
 DHRUVA LAHON, P.E.
 SERIAL NUMBER 102185

US 380 BLUE ALT AND
 CR 164
 AVERAGE DAILY TRAFFIC
 BLUE ALT BUILD VOLUMES



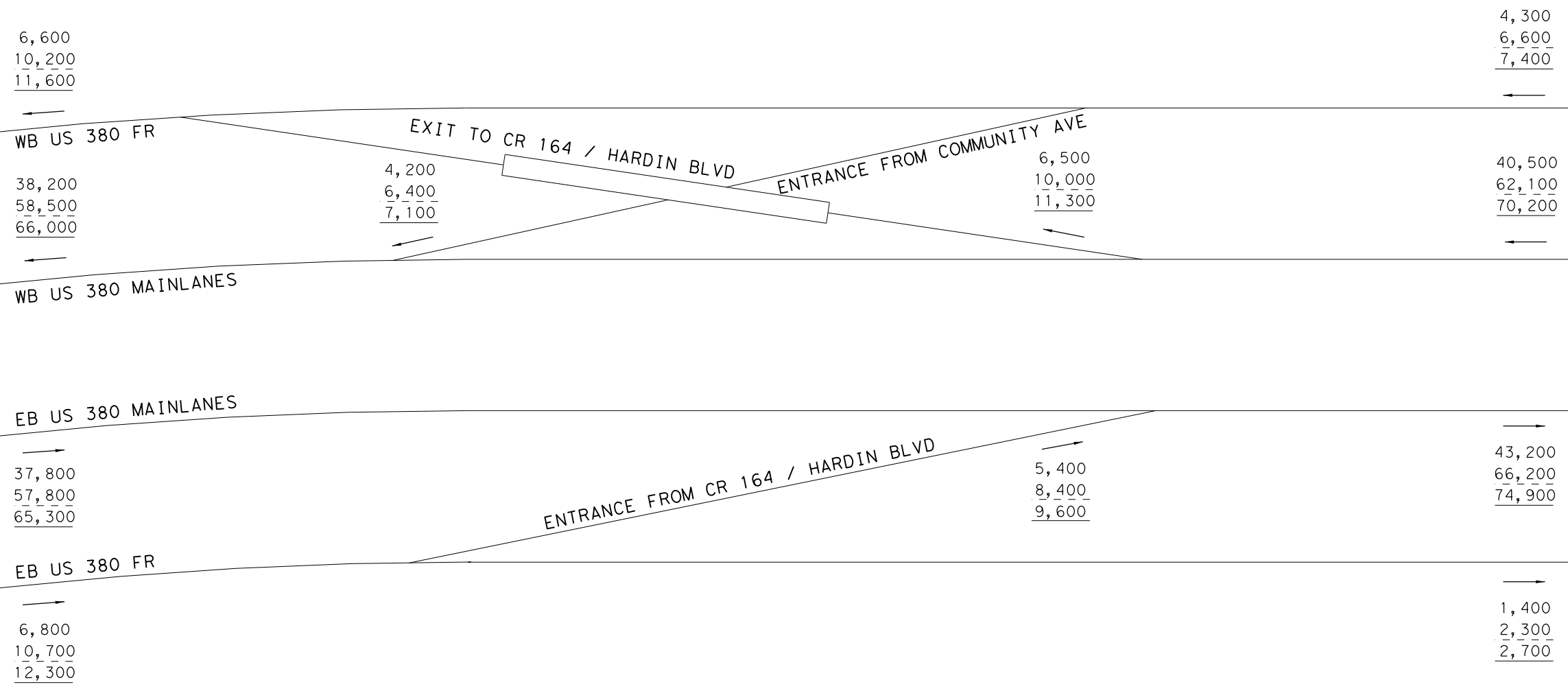
0135-02-065, ETC. SHEET 29 OF 63

DATE: 7/13/2021
 FILE: US380_BLUE_TRF_29.dgn



SEE SHEET 29 OF 63

SEE SHEET 31 OF 63



NOT TO SCALE

NOT INTENDED FOR CONSTRUCTION,
 BIDDING OR PERMIT PURPOSES
 DHRUVA LAHON, P.E.
 SERIAL NUMBER 102185

US 380 BLUE ALT AND
 RAMPS
 AVERAGE DAILY TRAFFIC
 BLUE ALT BUILD VOLUMES



0135-02-065,
 ETC. SHEET 30 OF 63

LEGEND

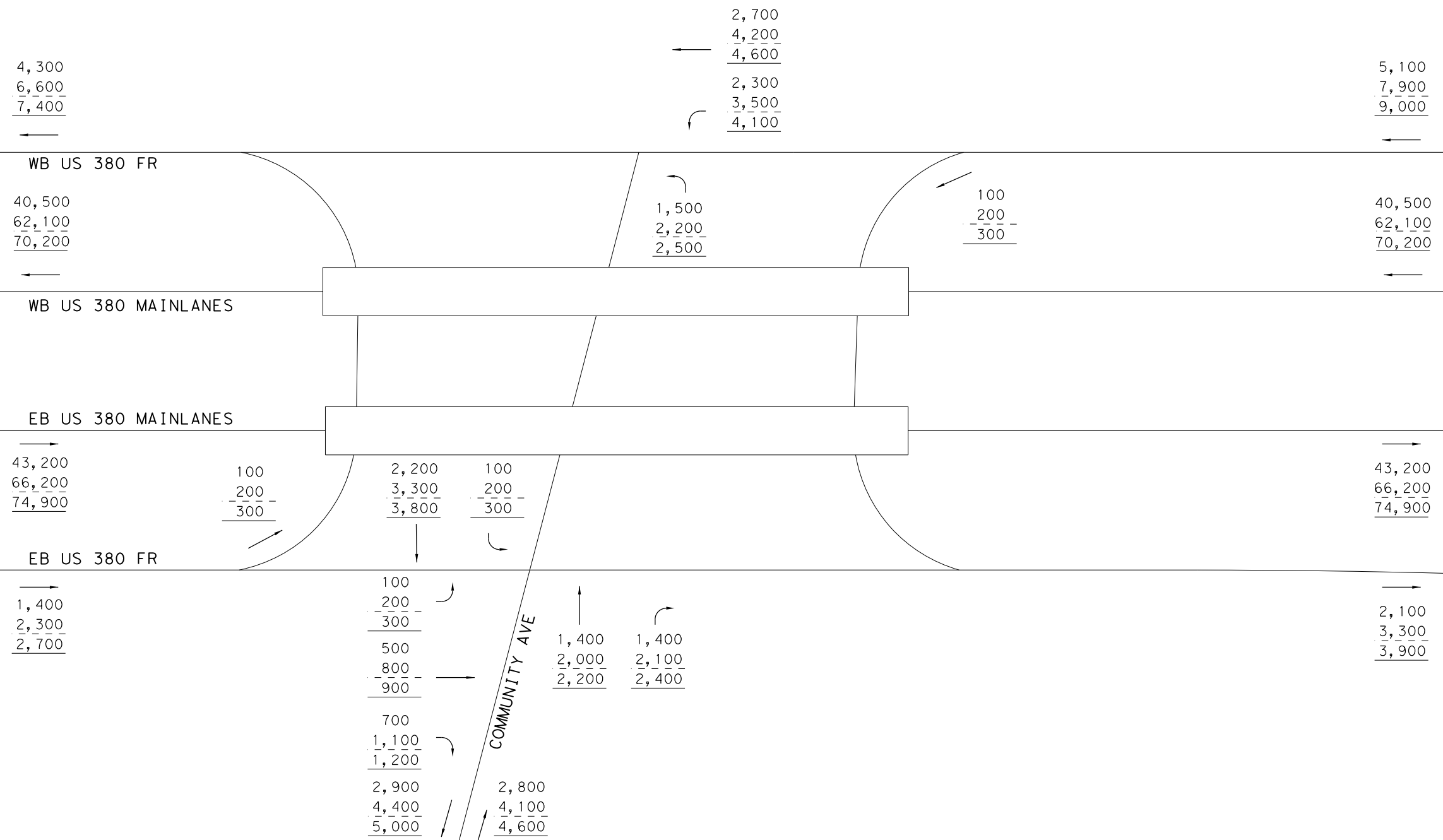
- XXXX- 2030 AVERAGE DAILY TRAFFIC VOLUMES
- XXXX- 2050 AVERAGE DAILY TRAFFIC VOLUMES
- XXXX- 2060 AVERAGE DAILY TRAFFIC VOLUMES

DATE: 7/13/2021
FILE: US380_BLUE_TRF_30.dgn



SEE SHEET 30 OF 63

SEE SHEET 32 OF 63



LEGEND

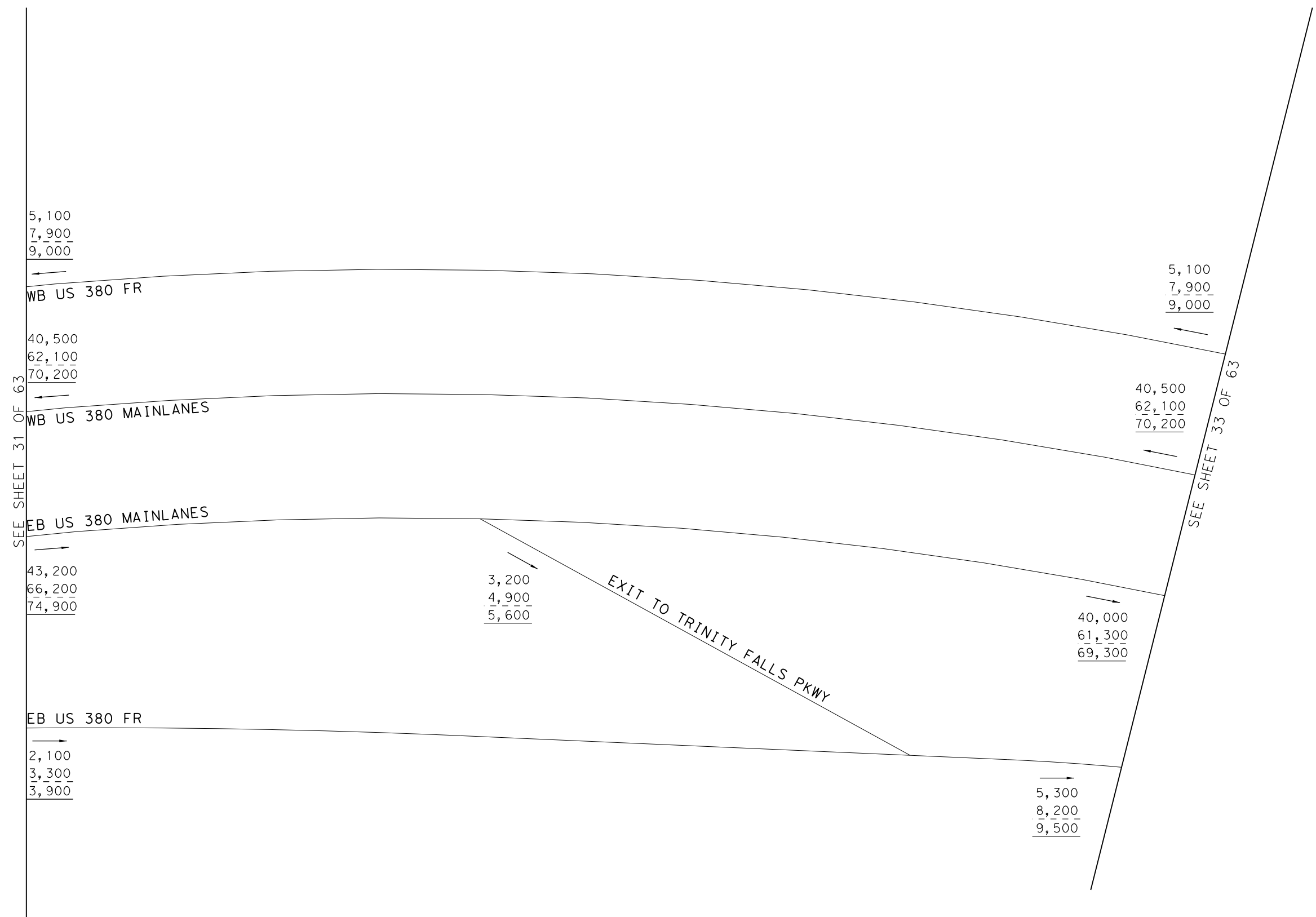
- XXXX- 2030 AVERAGE DAILY TRAFFIC VOLUMES
- XXXX- 2050 AVERAGE DAILY TRAFFIC VOLUMES
- XXXX- 2060 AVERAGE DAILY TRAFFIC VOLUMES

NOT TO SCALE

NOT INTENDED FOR CONSTRUCTION,
 BIDDING OR PERMIT PURPOSES
 DHRUVA LAHON, P.E.
 SERIAL NUMBER 102185

US 380 BLUE ALT AND
 COMMUNITY AVE
 AVERAGE DAILY TRAFFIC
 BLUE ALT BUILD VOLUMES





SEE SHEET 31 OF 63

SEE SHEET 33 OF 63

LEGEND

XXXX-	2030	AVERAGE	DAILY	TRAFFIC	VOLUMES
- XXXX-	2050	AVERAGE	DAILY	TRAFFIC	VOLUMES
- XXXX-	2060	AVERAGE	DAILY	TRAFFIC	VOLUMES

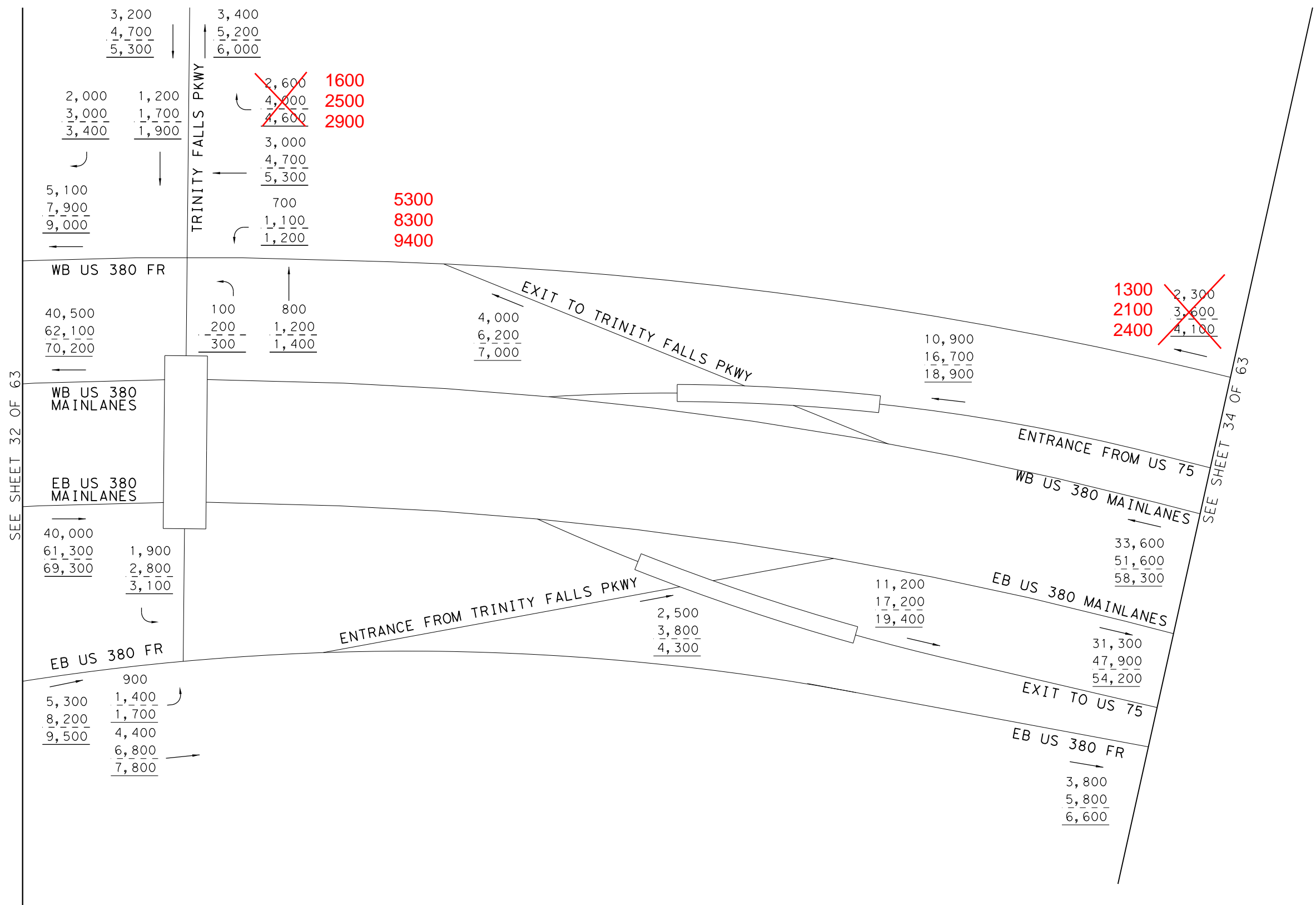
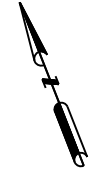
NOT TO SCALE

NOT INTENDED FOR CONSTRUCTION,
 BIDDING OR PERMIT PURPOSES
 DHRUVA LAHON, P.E.
 SERIAL NUMBER 102185

US 380 BLUE ALT AND
 RAMPS
 AVERAGE DAILY TRAFFIC
 BLUE ALT BUILD VOLUMES



DATE: 7/13/2021
 FILE: US380_BLUE_TRF_32.dgn



SEE SHEET 32 OF 63

SEE SHEET 34 OF 63

LEGEND

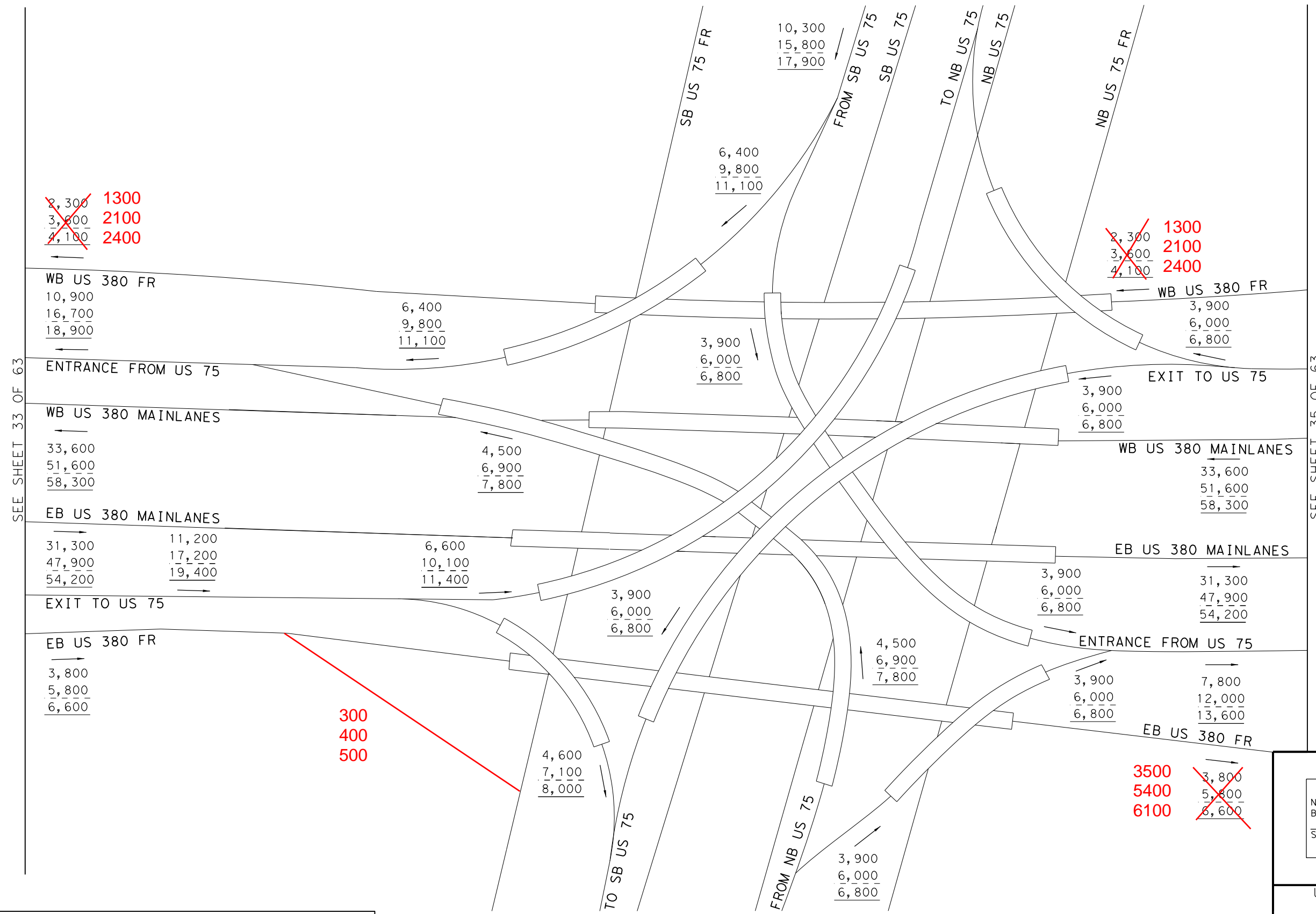
- XXXX- 2030 AVERAGE DAILY TRAFFIC VOLUMES
- XXXX- 2050 AVERAGE DAILY TRAFFIC VOLUMES
- XXXX- 2060 AVERAGE DAILY TRAFFIC VOLUMES

NOT TO SCALE

NOT INTENDED FOR CONSTRUCTION,
 BIDDING OR PERMIT PURPOSES
 DHRUVA LAHON, P.E.
 SERIAL NUMBER 102185

US 380 BLUE ALT AND
 TRINITY FALLS PKWY
 AVERAGE DAILY TRAFFIC
 BLUE ALT BUILD VOLUMES





SEE SHEET 33 OF 63

SEE SHEET 35 OF 63

NOT TO SCALE

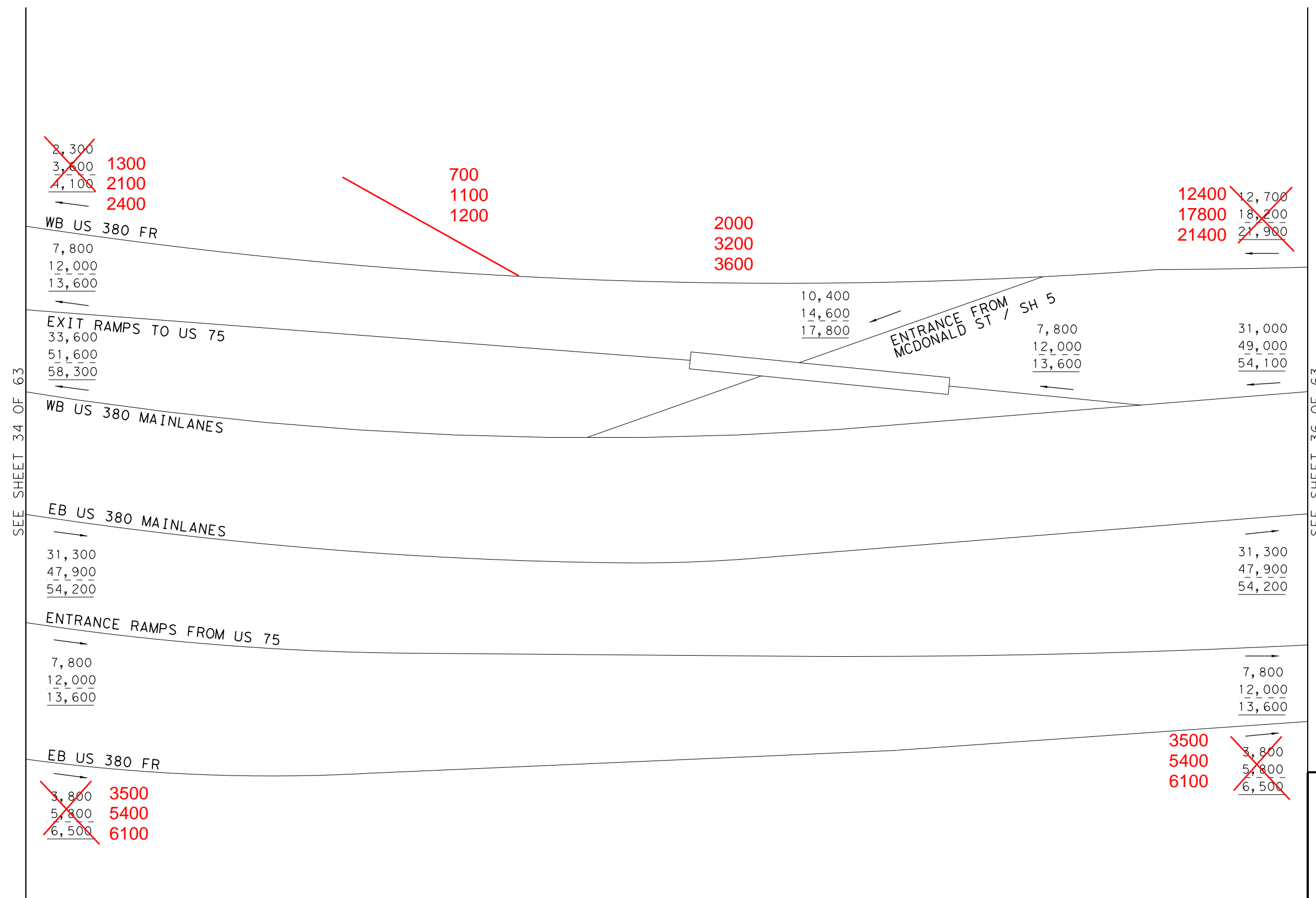
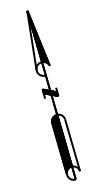
LEGEND

XXXX-	2030	AVERAGE DAILY TRAFFIC VOLUMES
-XXXX-	2050	AVERAGE DAILY TRAFFIC VOLUMES
XXXX-	2060	AVERAGE DAILY TRAFFIC VOLUMES

NOT INTENDED FOR CONSTRUCTION,
 BIDDING OR PERMIT PURPOSES
 DHRUVA LAHON, P.E.
 SERIAL NUMBER 102185

US 380 BLUE ALT AND
 US 75
 AVERAGE DAILY TRAFFIC
 BLUE ALT BUILD VOLUMES





~~2,300~~
~~3,600~~ 1300
~~4,100~~ 2100
 2400

700
 1100
 1200

2000
 3200
 3600

12400
 17800
 21400

~~12,700~~
~~18,200~~
~~21,900~~

7,800
 12,000
 13,600

10,400
 14,600
 17,800

7,800
 12,000
 13,600

31,000
 49,000
 54,100

33,600
 51,600
 58,300

31,300
 47,900
 54,200

31,300
 47,900
 54,200

7,800
 12,000
 13,600

7,800
 12,000
 13,600

~~3,800~~ 3500
~~5,800~~ 5400
~~6,500~~ 6100

3500
 5400
 6100

~~3,800~~
~~5,800~~
~~6,500~~

NOT TO SCALE

NOT INTENDED FOR CONSTRUCTION,
 BIDDING OR PERMIT PURPOSES
 DHRUVA LAHON, P.E.
 SERIAL NUMBER 102185

US 380 BLUE ALT AND
 WESTON RD
 AVERAGE DAILY TRAFFIC
 BLUE ALT BUILD VOLUMES

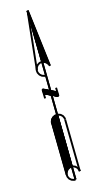
Kimley»Horn
F-928

0135-02-065,
 ETC. SHEET 35 OF 63

LEGEND

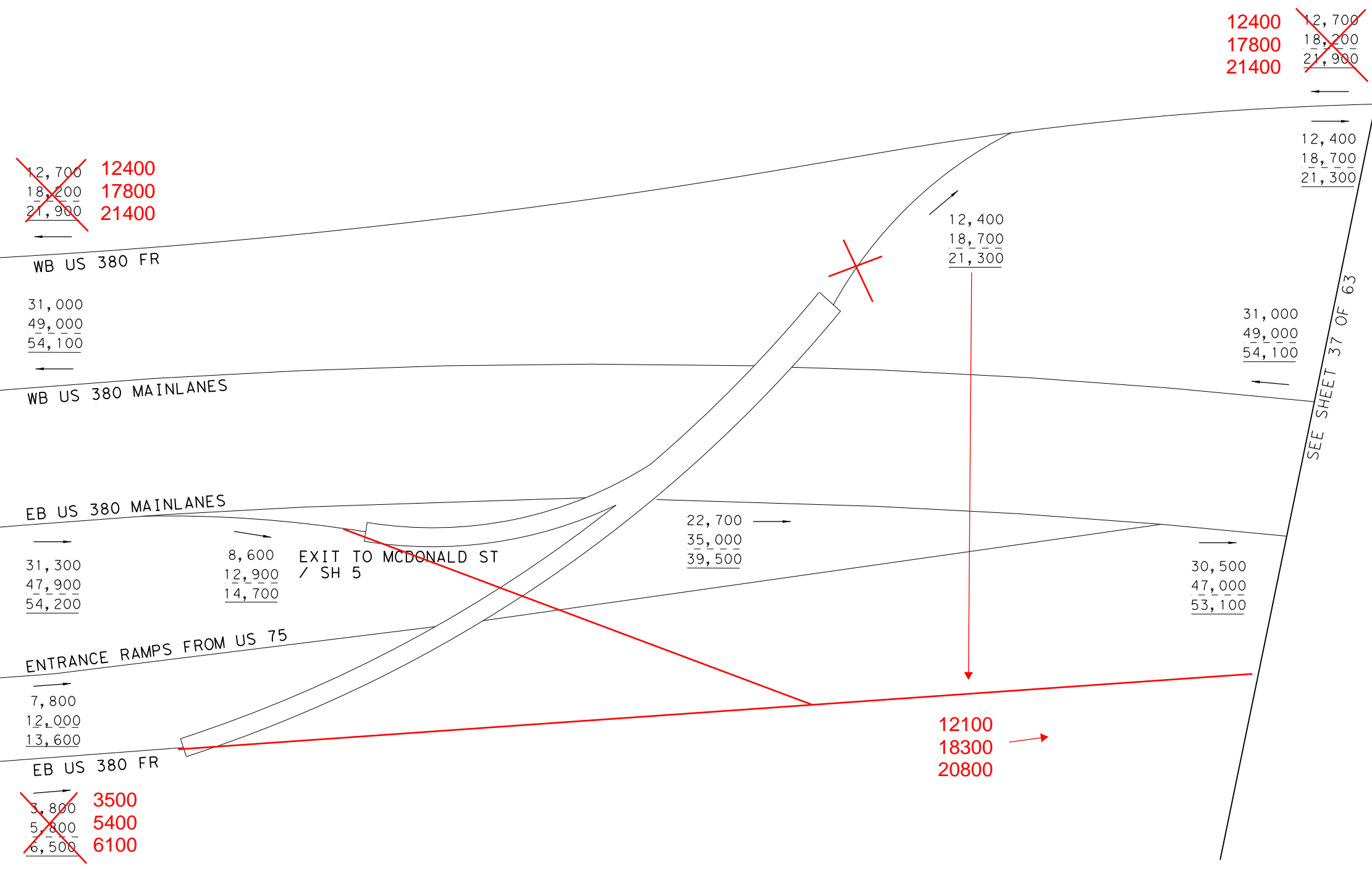
- XXXX- 2030 AVERAGE DAILY TRAFFIC VOLUMES
- XXXX- 2050 AVERAGE DAILY TRAFFIC VOLUMES
- XXXX- 2060 AVERAGE DAILY TRAFFIC VOLUMES

DATE: 7/13/2021
 FILE: US380_BLUE_TRF_35.dgn



SEE SHEET 35 OF 63

SEE SHEET 37 OF 63



LEGEND

- XXXX- 2030 AVERAGE DAILY TRAFFIC VOLUMES
- XXX- 2050 AVERAGE DAILY TRAFFIC VOLUMES
- XX- 2060 AVERAGE DAILY TRAFFIC VOLUMES

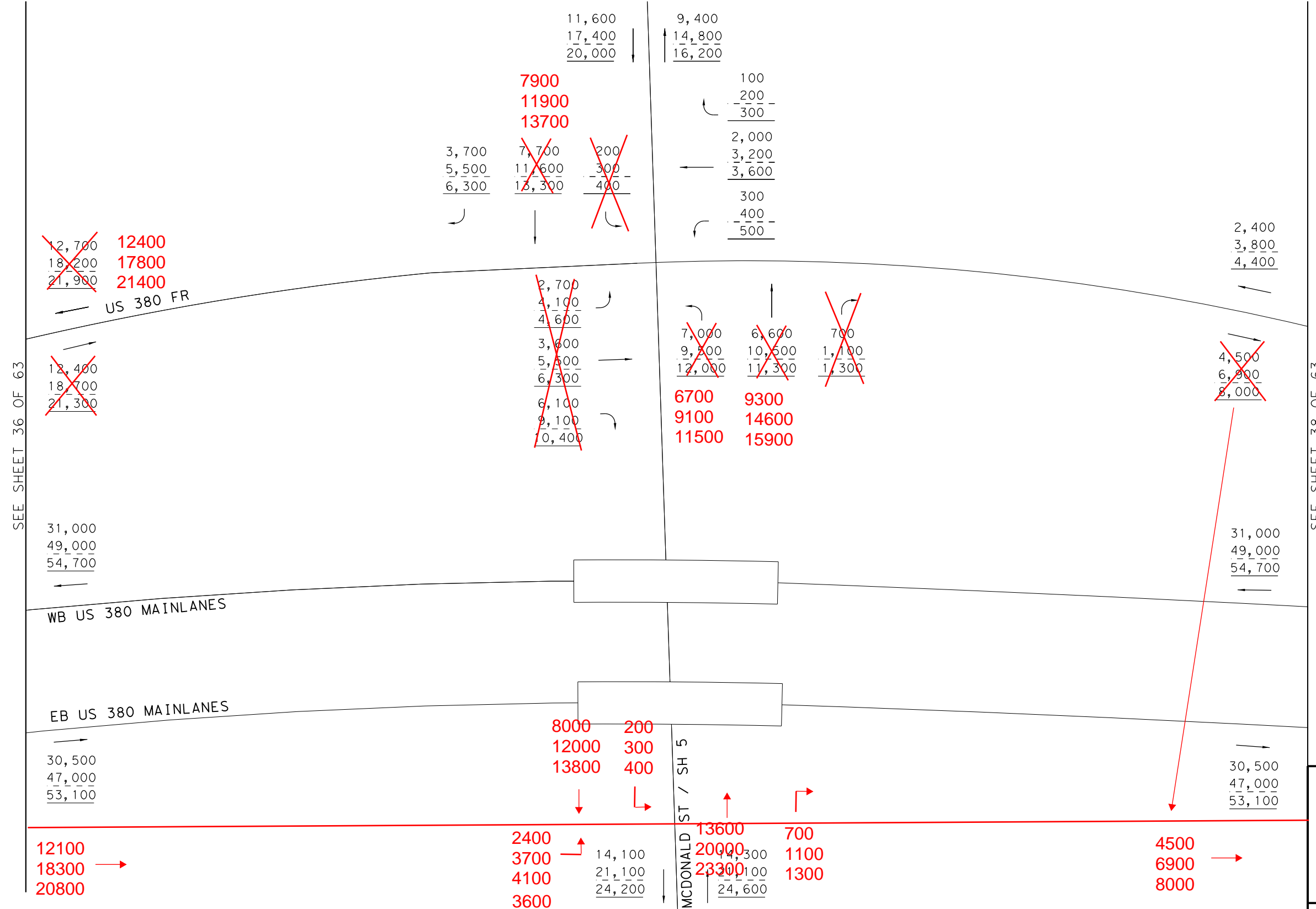
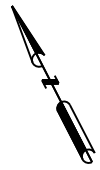
NOT TO SCALE

NOT INTENDED FOR CONSTRUCTION,
 BIDDING OR PERMIT PURPOSES
 DHRUVA LAHON, P.E.
 SERIAL NUMBER 102185

US 380 BLUE ALT AND
 RAMP
 AVERAGE DAILY TRAFFIC
 BLUE ALT BUILD VOLUMES



DATE: 7/13/2021
 FILE: US380_BLUE_TRF_36.dgn



SEE SHEET 36 OF 63

SEE SHEET 38 OF 63

NOT TO SCALE

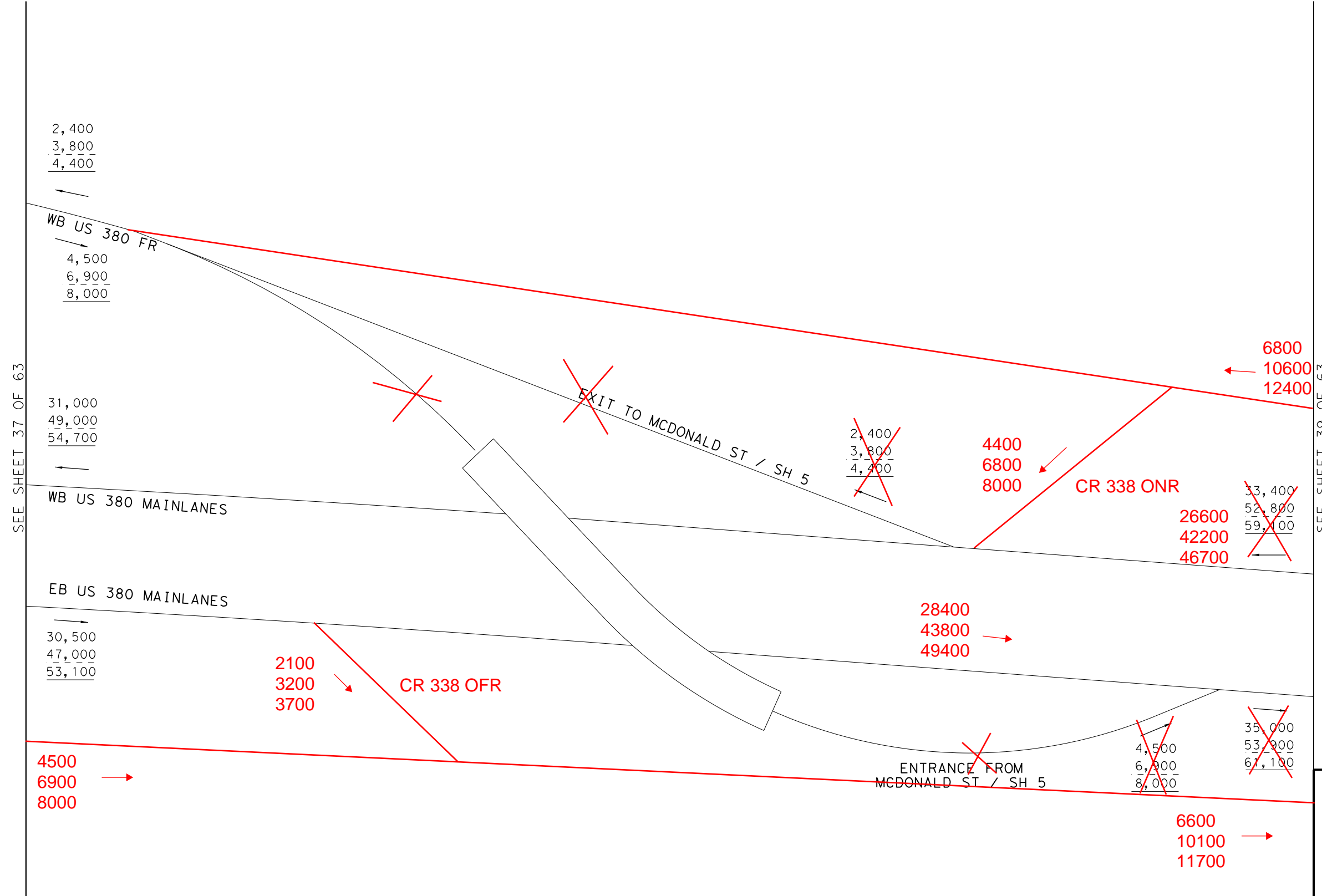
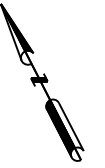
NOT INTENDED FOR CONSTRUCTION,
 BIDDING OR PERMIT PURPOSES
 DHRUVA LAHON, P.E.
 SERIAL NUMBER 102185

US 380 BLUE ALT AND
 MCDONALD ST / SH 5
 AVERAGE DAILY TRAFFIC
 BLUE ALT BUILD VOLUMES



LEGEND	
XXXX-	2030 AVERAGE DAILY TRAFFIC VOLUMES
-XXXX-	2050 AVERAGE DAILY TRAFFIC VOLUMES
XXXX-	2060 AVERAGE DAILY TRAFFIC VOLUMES

DATE: 7/13/2021
 FILE: US380_BLUE_TRF_37.dgn



SEE SHEET 37 OF 63

SEE SHEET 39 OF 63

NOT TO SCALE

NOT INTENDED FOR CONSTRUCTION,
 BIDDING OR PERMIT PURPOSES
 DHRUVA LAHON, P.E.
 SERIAL NUMBER 102185

US 380 BLUE ALT AND
 RAMPS
 AVERAGE DAILY TRAFFIC
 BLUE ALT BUILD VOLUMES

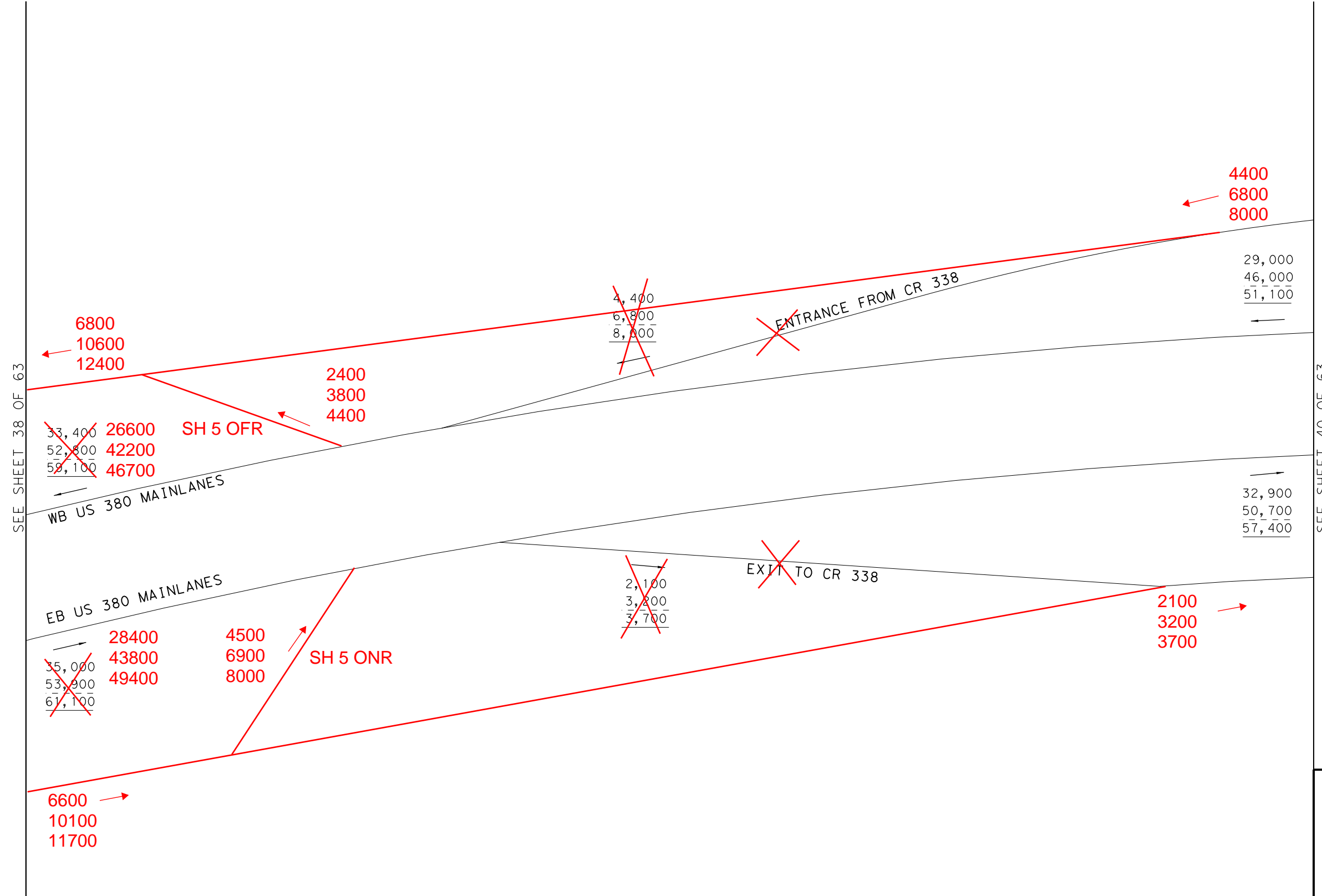
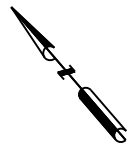


0135-02-065,
 ETC. SHEET 38 OF 63

LEGEND

- XXXX- 2030 AVERAGE DAILY TRAFFIC VOLUMES
- XXXX- 2050 AVERAGE DAILY TRAFFIC VOLUMES
- XXXX- 2060 AVERAGE DAILY TRAFFIC VOLUMES

DATE: 7/13/2021
FILE: US380_BLUE_TRF_38.dgn



SEE SHEET 38 OF 63

SEE SHEET 40 OF 63

NOT TO SCALE

NOT INTENDED FOR CONSTRUCTION,
 BIDDING OR PERMIT PURPOSES
 DHRUVA LAHON, P.E.
 SERIAL NUMBER 102185

US 380 BLUE ALT AND
 RAMPS
 AVERAGE DAILY TRAFFIC
 BLUE ALT BUILD VOLUMES

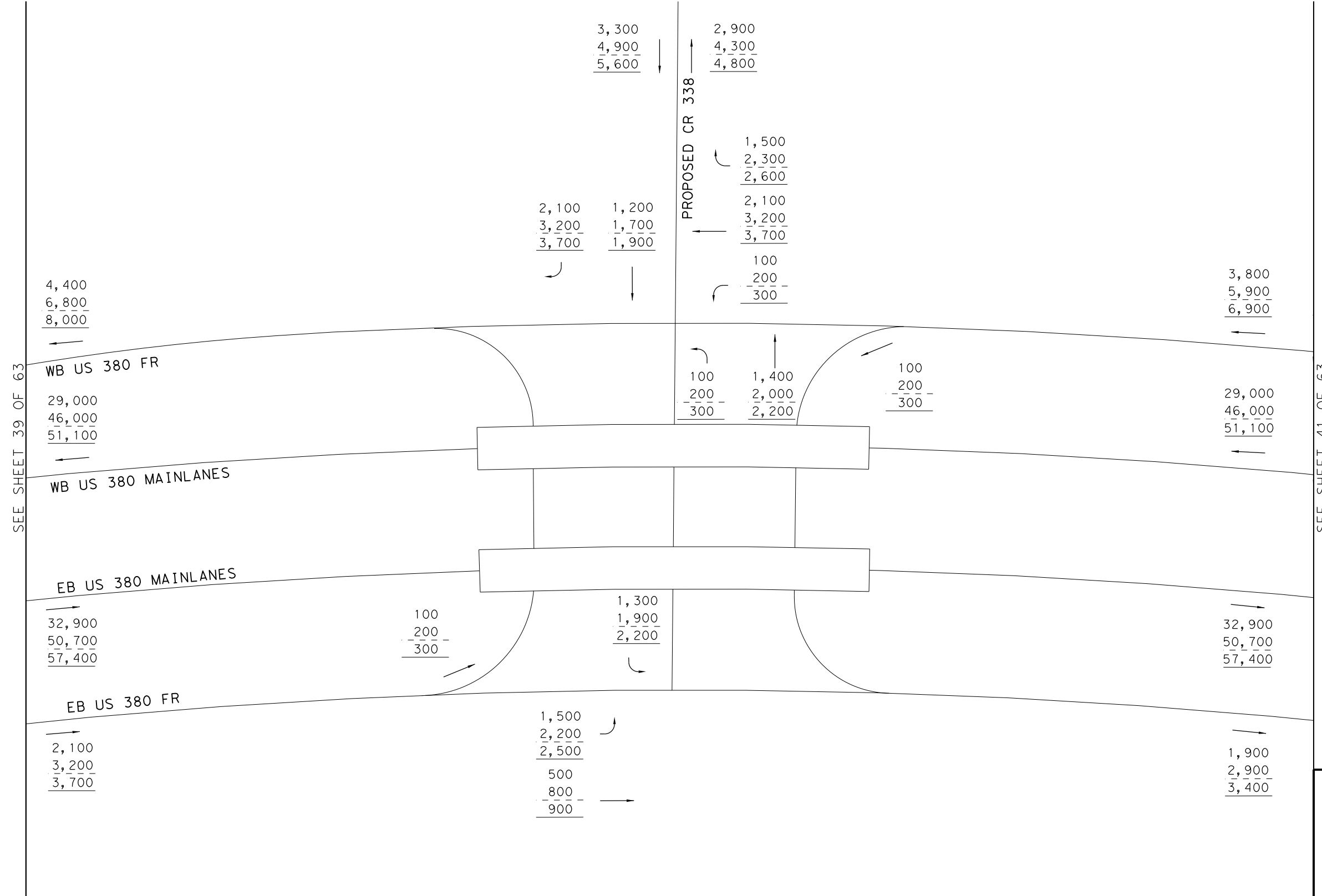
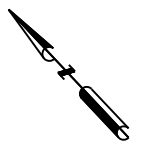


0135-02-065,
 ETC. SHEET 39 OF 63

LEGEND

- XXXX- 2030 AVERAGE DAILY TRAFFIC VOLUMES
- XXXX- 2050 AVERAGE DAILY TRAFFIC VOLUMES
- XXXX- 2060 AVERAGE DAILY TRAFFIC VOLUMES

DATE: 7/13/2021
 FILE: US380_BLUE_TRF_39.dgn



SEE SHEET 39 OF 63

SEE SHEET 41 OF 63

NOT TO SCALE

NOT INTENDED FOR CONSTRUCTION,
 BIDDING OR PERMIT PURPOSES
 DHRUVA LAHON, P.E.
 SERIAL NUMBER 102185

US 380 BLUE ALT AND
 CR 338
 AVERAGE DAILY TRAFFIC
 BLUE ALT BUILD VOLUMES

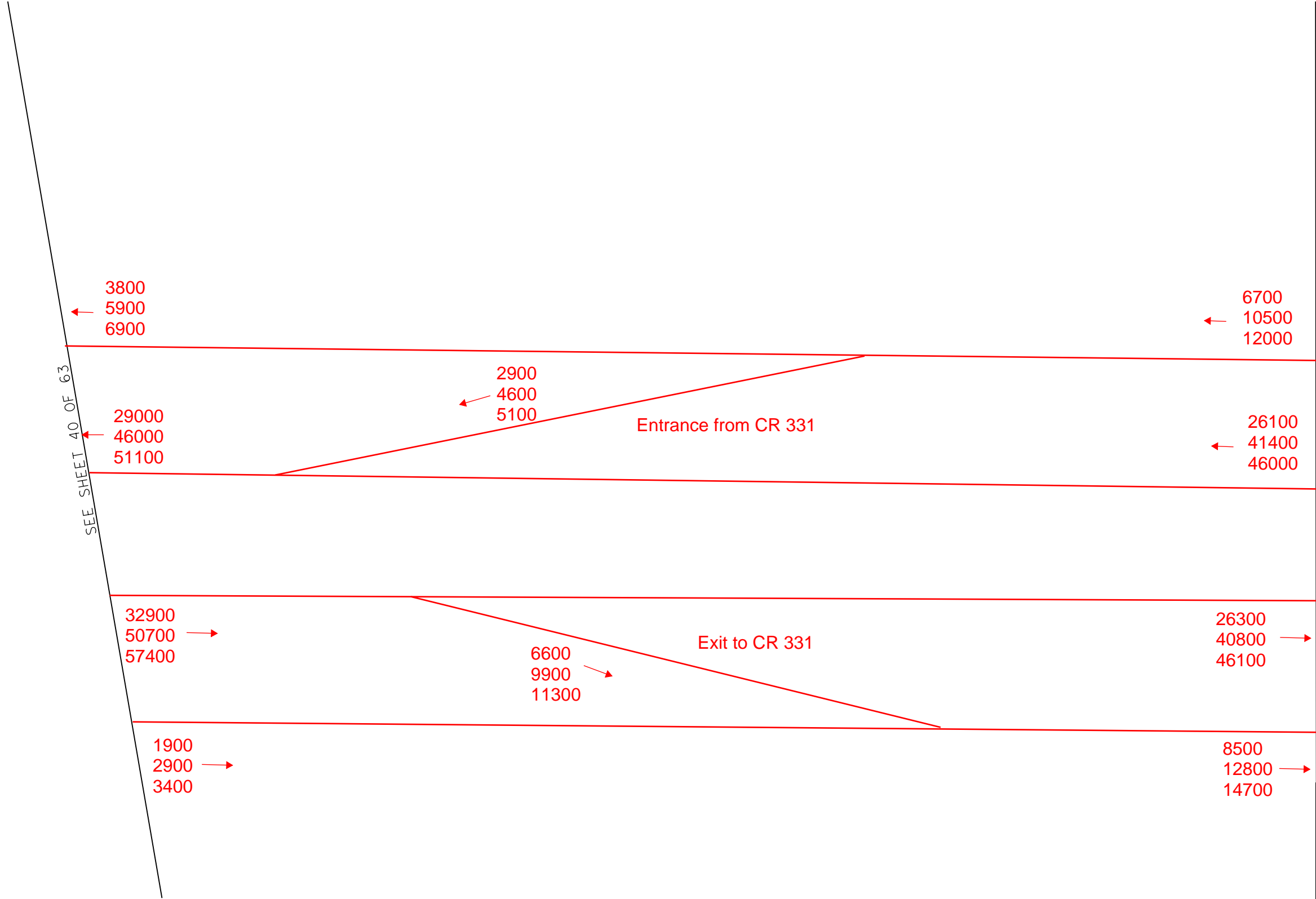
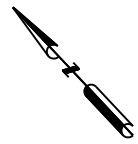


0135-02-065,
 ETC. SHEET 40 OF 63

LEGEND

- XXXX- 2030 AVERAGE DAILY TRAFFIC VOLUMES
- XXXX- 2050 AVERAGE DAILY TRAFFIC VOLUMES
- XXXX- 2060 AVERAGE DAILY TRAFFIC VOLUMES

DATE: 7/13/2021
 FILE: US380_BLUE_TRF_40.dgn



NOT TO SCALE

NOT INTENDED FOR CONSTRUCTION,
 BIDDING OR PERMIT PURPOSES
 DHRUVA LAHON, P.E.
 SERIAL NUMBER 102185

US 380 BLUE ALT AND
 RAMPS
 AVERAGE DAILY TRAFFIC
 BLUE ALT BUILD VOLUMES



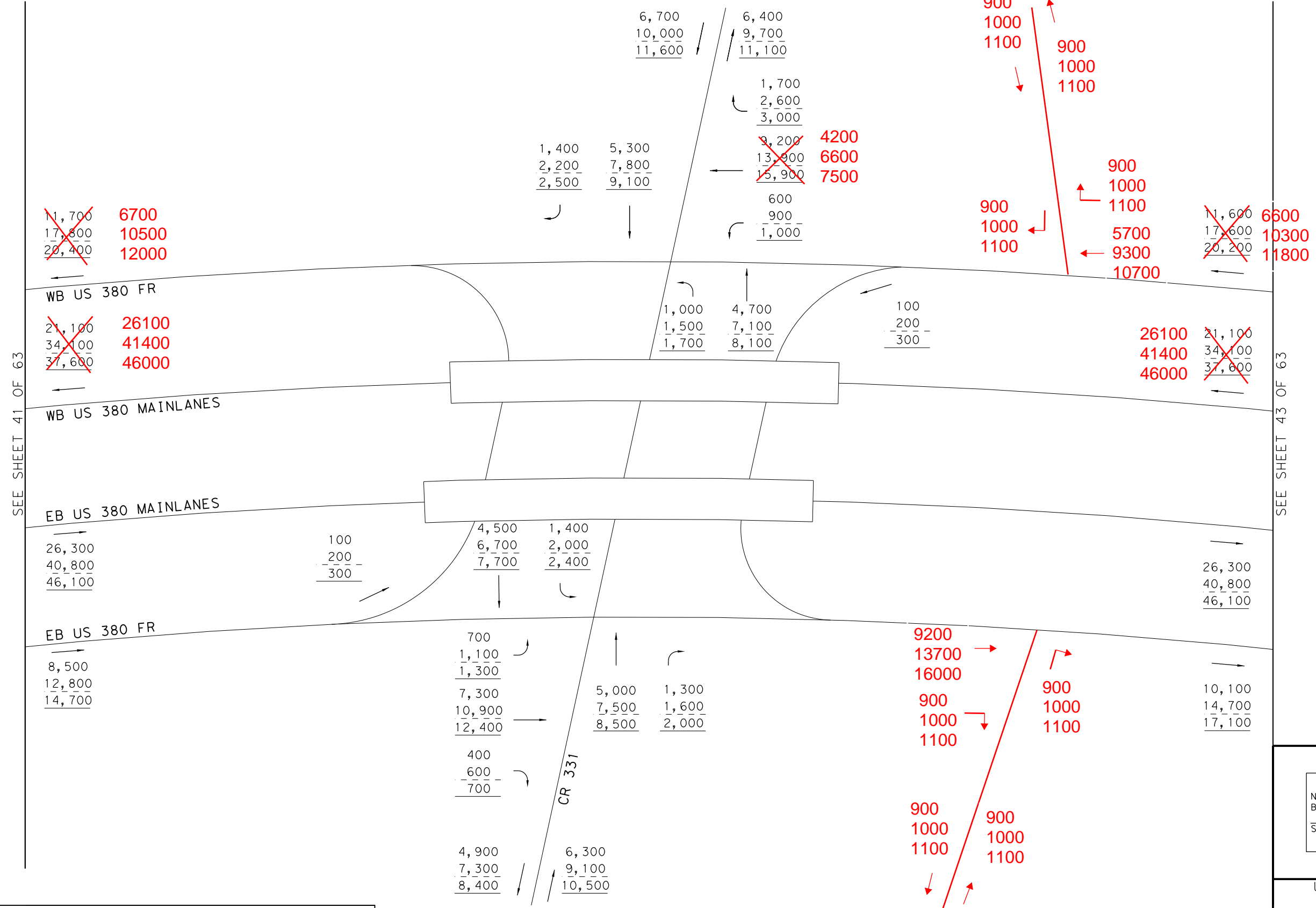
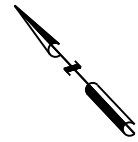
0135-02-065,
 ETC. SHEET 41 OF 63

LEGEND

- XXXX- 2030 AVERAGE DAILY TRAFFIC VOLUMES
- XXXX- 2050 AVERAGE DAILY TRAFFIC VOLUMES
- XXXX- 2060 AVERAGE DAILY TRAFFIC VOLUMES

DATE: 7/13/2021
 FILE: US380_BLUE_TRF_41.dgn

The interchange is being built by the City where it shows only U-turns in Schematic. So leave the interchange volumes.



SEE SHEET 41 OF 63

SEE SHEET 43 OF 63

~~11,700~~ **6700**
~~17,800~~ **10500**
~~20,400~~ **12000**

~~21,100~~ **26100**
~~34,100~~ **41400**
~~37,600~~ **46000**

WB US 380 FR

WB US 380 MAINLANES

EB US 380 MAINLANES

EB US 380 FR

CR 331

~~11,600~~ **6600**
~~17,600~~ **10300**
~~20,200~~ **11800**

26100 ~~21,100~~
41400 ~~34,100~~
46000 ~~37,600~~

26,300
40,800
46,100

10,100
14,700
17,100

LEGEND

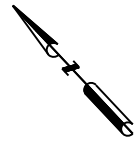
- XXXX- 2030 AVERAGE DAILY TRAFFIC VOLUMES
- XXXX- 2050 AVERAGE DAILY TRAFFIC VOLUMES
- XXXX- 2060 AVERAGE DAILY TRAFFIC VOLUMES

NOT TO SCALE

NOT INTENDED FOR CONSTRUCTION,
 BIDDING OR PERMIT PURPOSES
 DHRUVA LAHON, P.E.
 SERIAL NUMBER 102185

US 380 BLUE ALT AND
 CR 331
 AVERAGE DAILY TRAFFIC
 BLUE ALT BUILD VOLUMES





SEE SHEET 42 OF 63

SEE SHEET 44 OF 63

11,600	6600
17,600	10300
20,200	11800

3600	8,600
5800	13,100
6700	15,100

WB US 380 FR	
21,100	26100
34,100	41400
37,600	46000

3,000
<u>4,500</u>
<u>5,100</u>

29100	24,100
45900	38,600
51100	42,700

EXIT TO CR 331

WB US 380 MAINLANES

EB US 380 MAINLANES

→
26,300
<u>40,800</u>
<u>46,100</u>

→
30,100
<u>46,500</u>
<u>52,600</u>

→
3,800
<u>5,700</u>
<u>6,500</u>

ENTRANCE FROM CR 331

EB US 380 FR	
→	
10,100	
<u>14,700</u>	
<u>17,100</u>	

→
6,300
<u>9,000</u>
<u>10,600</u>

NOT TO SCALE

NOT INTENDED FOR CONSTRUCTION,
BIDDING OR PERMIT PURPOSES
DHURVA LAHON, P.E.
SERIAL NUMBER 102185

US 380 BLUE ALT AND
RAMPS
AVERAGE DAILY TRAFFIC
BLUE ALT BUILD VOLUMES

Kimley»Horn
F-928

0135-02-065,
ETC. SHEET 43 OF 63

LEGEND

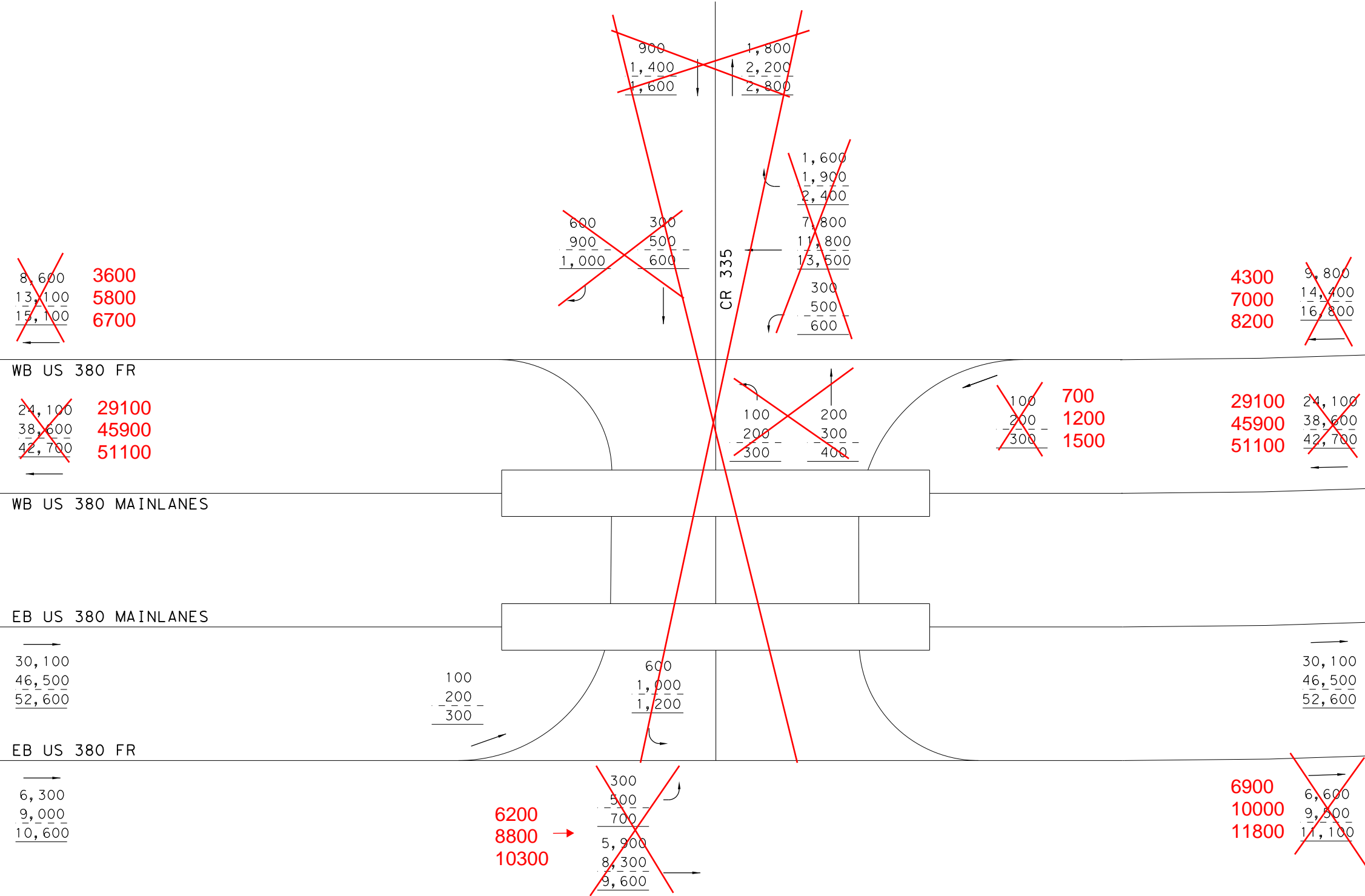
- XXXX- 2030 AVERAGE DAILY TRAFFIC VOLUMES
- XXXX- 2050 AVERAGE DAILY TRAFFIC VOLUMES
- XXXX- 2060 AVERAGE DAILY TRAFFIC VOLUMES

DATE: 7/13/2021
FILE: US380_BLUE_TRF_43.dgn



SEE SHEET 43 OF 63

SEE SHEET 44A OF 63



LEGEND

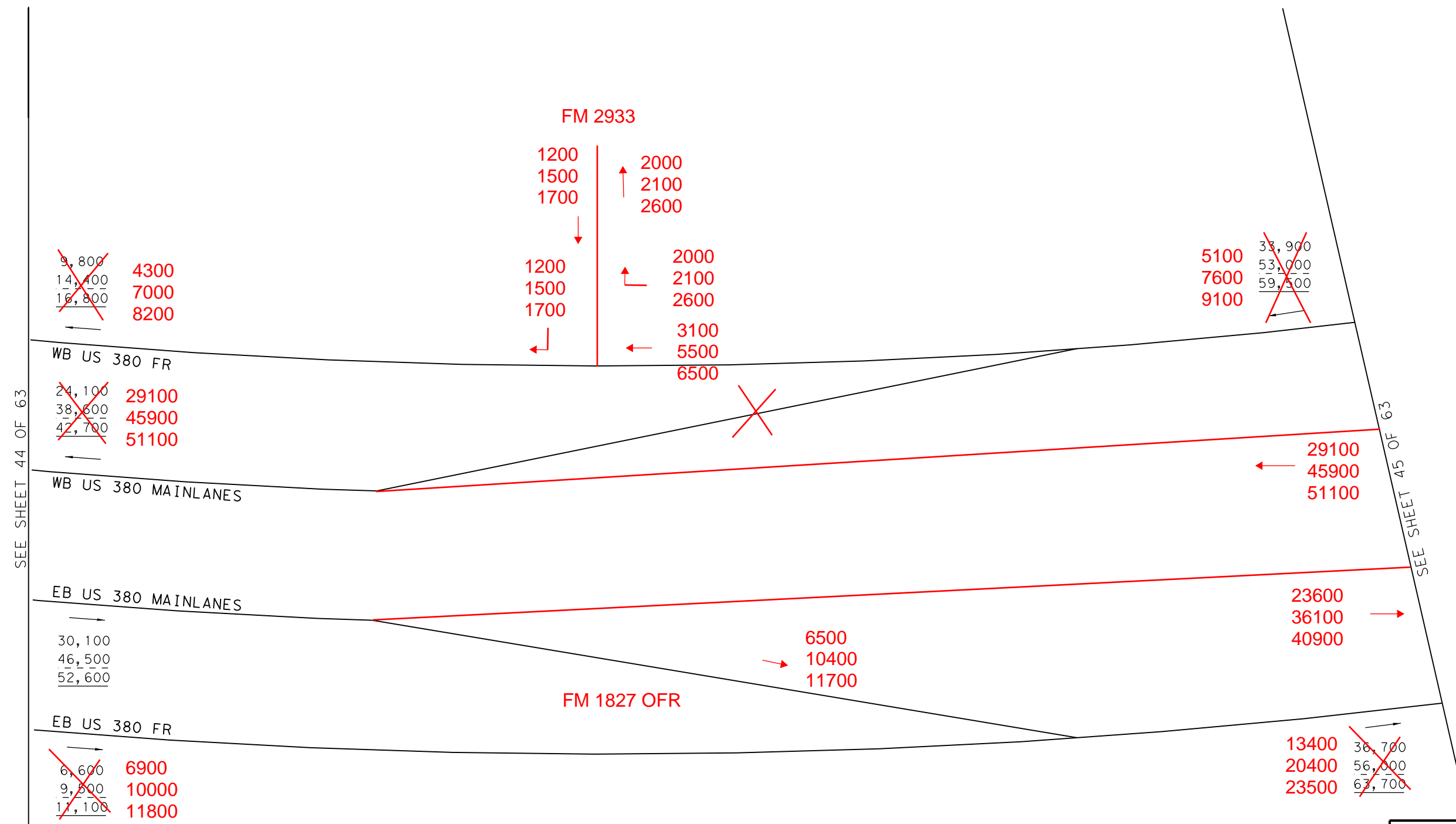
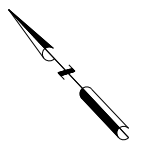
- XXXX- 2030 AVERAGE DAILY TRAFFIC VOLUMES
- XXXX- 2050 AVERAGE DAILY TRAFFIC VOLUMES
- XXXX- 2060 AVERAGE DAILY TRAFFIC VOLUMES

NOT TO SCALE

NOT INTENDED FOR CONSTRUCTION,
 BIDDING OR PERMIT PURPOSES
 DHRUVA LAHON, P.E.
 SERIAL NUMBER 102185

US 380 BLUE ALT AND
 CR 335
 AVERAGE DAILY TRAFFIC
 BLUE ALT BUILD VOLUMES





SEE SHEET 44 OF 63

SEE SHEET 45 OF 63

NOT TO SCALE

NOT INTENDED FOR CONSTRUCTION,
 BIDDING OR PERMIT PURPOSES
 DHRUVA LAHON, P.E.
 SERIAL NUMBER 102185

US 380 BLUE ALT AND
 RAMPS
 AVERAGE DAILY TRAFFIC
 BLUE ALT BUILD VOLUMES



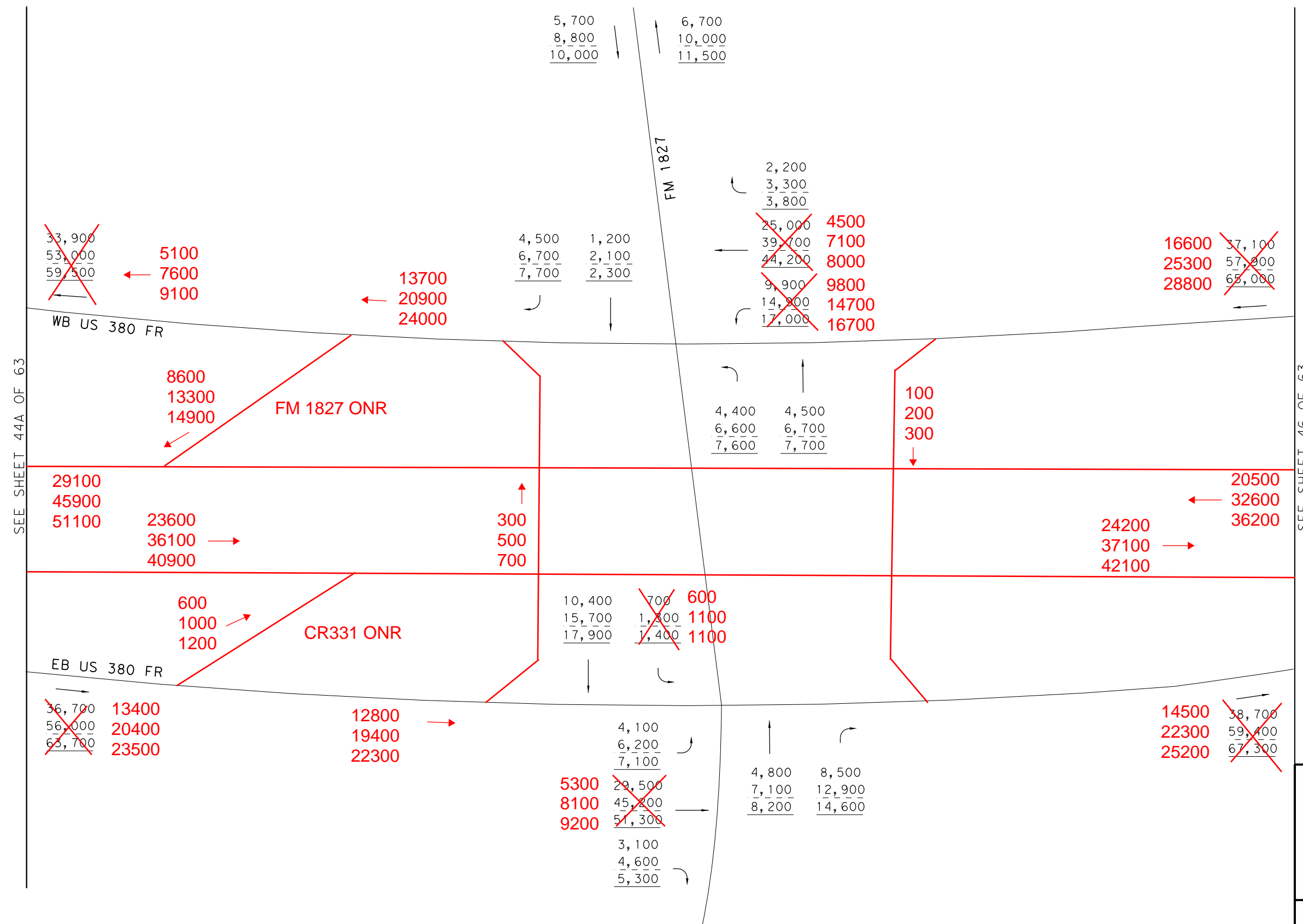
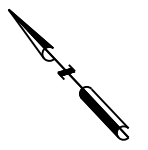
0135-02-065,
 ETC. SHEET 44A OF 63

LEGEND

- XXXX- 2030 AVERAGE DAILY TRAFFIC VOLUMES
- XXXX- 2050 AVERAGE DAILY TRAFFIC VOLUMES
- XXXX- 2060 AVERAGE DAILY TRAFFIC VOLUMES

NOTE: SEE US 380 PRINCETON PROJECT
 FOR US 380, FROM FM 1827 EASTWARD

DATE: 7/13/2021
 FILE: US380_BLUE_TRF_44a.dgn



SEE SHEET 44A OF 63

SEE SHEET 46 OF 63

SEE SHEET 63 OF 63

NOT TO SCALE

NOT INTENDED FOR CONSTRUCTION,
 BIDDING OR PERMIT PURPOSES
 DHRUVA LAHON, P.E.
 SERIAL NUMBER 102185

US 380 BLUE ALT AND
 NEW HOPE ROAD/ FM 1827
 AVERAGE DAILY TRAFFIC
 BLUE ALT BUILD VOLUMES

Kimley»Horn
F-928

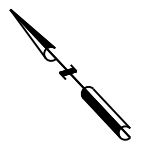
0135-02-065,
 ETC. SHEET 45 OF 63

LEGEND

- XXXX- 2030 AVERAGE DAILY TRAFFIC VOLUMES
- XXXX- 2050 AVERAGE DAILY TRAFFIC VOLUMES
- XXXX- 2060 AVERAGE DAILY TRAFFIC VOLUMES

NOTE: SEE US 380 PRINCETON PROJECT
 FOR US 380, FROM FM 1827 EASTWARD

DATE: 7/13/2021
 FILE: US380_BLUE_TRF_45.dgn



SEE SHEET 45 OF 63

37,100	16600
57,900	25300
65,000	28800

FM 1827 OFR

←	20500
←	32600
←	36200

→	24200
→	37100
→	42100

FM 1827 ONR

→	14500
38,700	22300
59,400	25200
67,300	

37,100
57,900
65,000

WB US 380 MAINLANES
EB US 380 MAINLANES

38,700
59,400
67,300

NOT TO SCALE

NOT INTENDED FOR CONSTRUCTION,
BIDDING OR PERMIT PURPOSES
DHURVA LAHON, P.E.
SERIAL NUMBER 102185

US 380 BLUE ALT AND
RAMPS
AVERAGE DAILY TRAFFIC
BLUE ALT BUILD VOLUMES

Kimley»Horn
F-928

0135-02-065,
ETC. SHEET 46 OF 63

LEGEND

- XXXX- 2030 AVERAGE DAILY TRAFFIC VOLUMES
- XXXX- 2050 AVERAGE DAILY TRAFFIC VOLUMES
- XXXX- 2060 AVERAGE DAILY TRAFFIC VOLUMES

NOTE: SEE US 380 PRINCETON PROJECT
FOR US 380, FROM FM 1827 EASTWARD

DATE: 7/13/2021
FILE: US380_BLUE_TRF_46.dgn



SEE SHEET 11A OF 63

SEE SHEET 48 OF 63

13,200
 20,300
22,900

11,300
 17,300
19,600
 4,400
 6,800
7,700

15,700
 24,100
27,300

WB US 380 EXISTING
 EB US 380 EXISTING

13,200
 20,300
22,900

10,600
 16,300
18,300
 2,600
 4,000
4,600

1,900 4,700
3,000 7,300
 3,300 8,200

15,300
 23,600
26,500

7,000
 10,800
12,300

6,600
 10,300
11,500

RIDGE ROAD

NOT TO SCALE

NOT INTENDED FOR CONSTRUCTION,
 BIDDING OR PERMIT PURPOSES
 DHRUVA LAHON, P.E.
 SERIAL NUMBER 102185

EXISTING US 380 AND
 RIDGE RD
 AVERAGE DAILY TRAFFIC

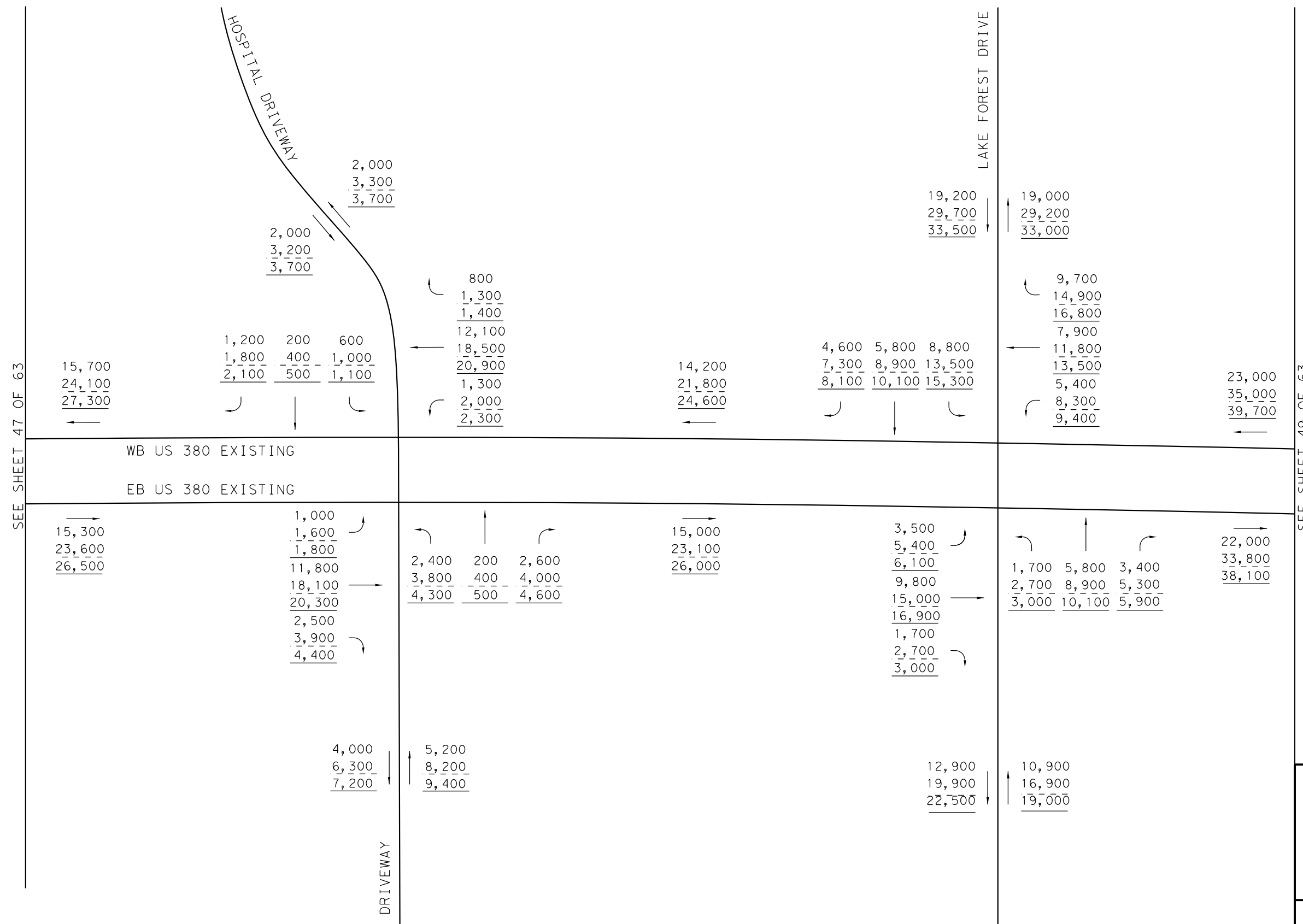
Kimley»Horn
F-928

0135-02-065,
 ETC. SHEET 47 OF 63

LEGEND

- XXXX- 2030 AVERAGE DAILY TRAFFIC VOLUMES
- XXXX- 2050 AVERAGE DAILY TRAFFIC VOLUMES
- XXXX- 2060 AVERAGE DAILY TRAFFIC VOLUMES

DATE: 7/13/2021
 FILE: US380_BLUE_TRF_47.dgn



SEE SHEET 47 OF 63

SEE SHEET 49 OF 63

WB US 380 EXISTING

EB US 380 EXISTING

LEGEND

- XXXX- 2030 AVERAGE DAILY TRAFFIC VOLUMES
- XXXX- 2050 AVERAGE DAILY TRAFFIC VOLUMES
- XXXX- 2060 AVERAGE DAILY TRAFFIC VOLUMES

NOT TO SCALE

NOT INTENDED FOR CONSTRUCTION,
BIDDING OR PERMIT PURPOSES
DHURVA LAHON, P.E.
SERIAL NUMBER 102185

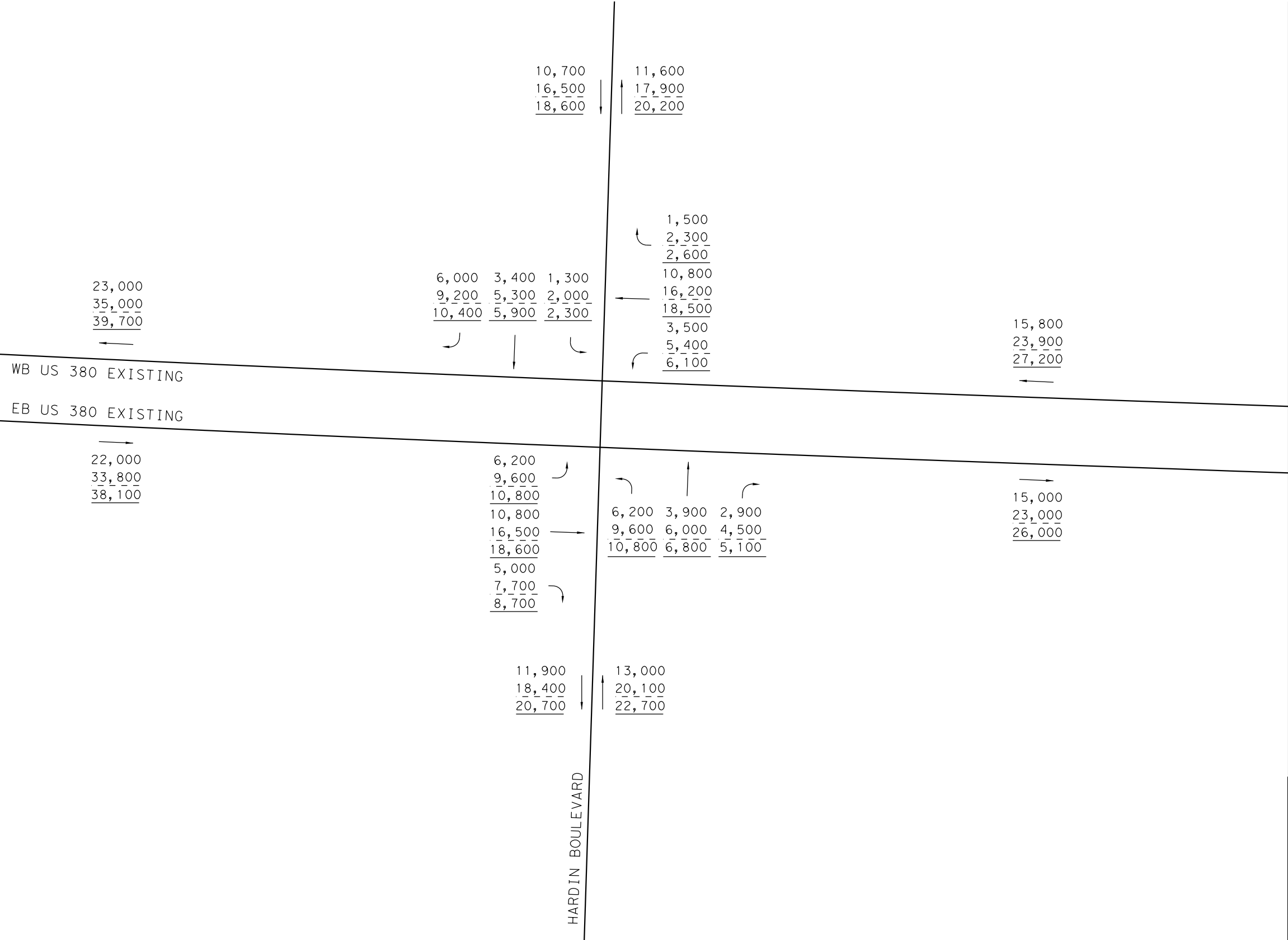
EXISTING US 380 AND
LAKE FOREST DR
AVERAGE DAILY TRAFFIC

Kimley»Horn
F-928



SEE SHEET 48 OF 63

SEE SHEET 50 OF 63



LEGEND

- XXXX- 2030 AVERAGE DAILY TRAFFIC VOLUMES
- XXXX- 2050 AVERAGE DAILY TRAFFIC VOLUMES
- XXXX- 2060 AVERAGE DAILY TRAFFIC VOLUMES

NOT TO SCALE

NOT INTENDED FOR CONSTRUCTION,
 BIDDING OR PERMIT PURPOSES
 DHRUVA LAHON, P.E.
 SERIAL NUMBER 102185

EXISTING US 380 AND HARDIN BLVD AVERAGE DAILY TRAFFIC

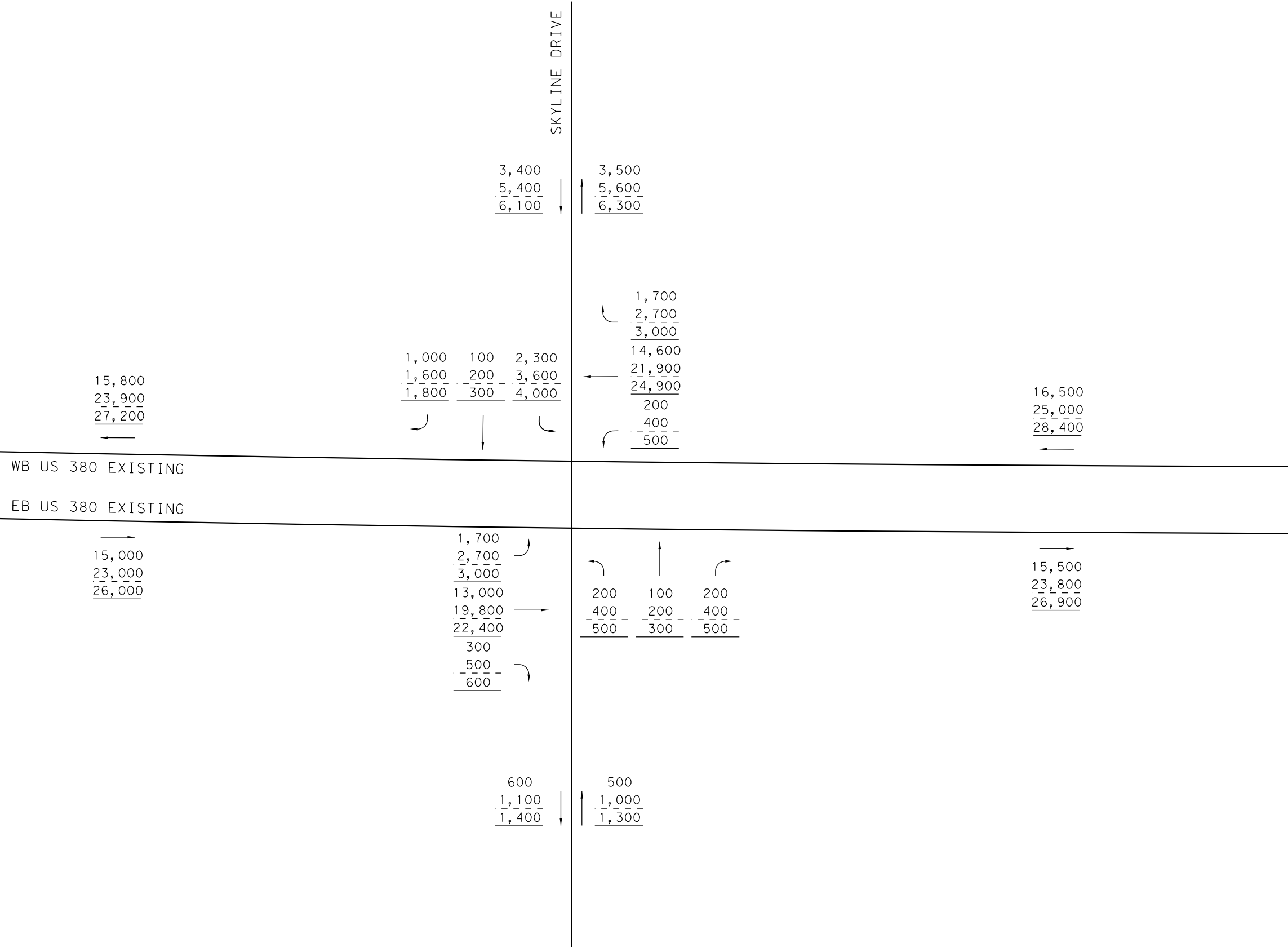


DATE: 7/13/2021 FILE: US380_BLUE_TRF_49.dgn



SEE SHEET 49 OF 63

SEE SHEET 51 OF 63



NOT TO SCALE

NOT INTENDED FOR CONSTRUCTION,
 BIDDING OR PERMIT PURPOSES
 DHRUVA LAHON, P.E.
 SERIAL NUMBER 102185

EXISTING US 380 AND
 SKYLINE DR
 AVERAGE DAILY TRAFFIC

Kimley»Horn
F-928

0135-02-065,
 ETC. SHEET 50 OF 63

LEGEND

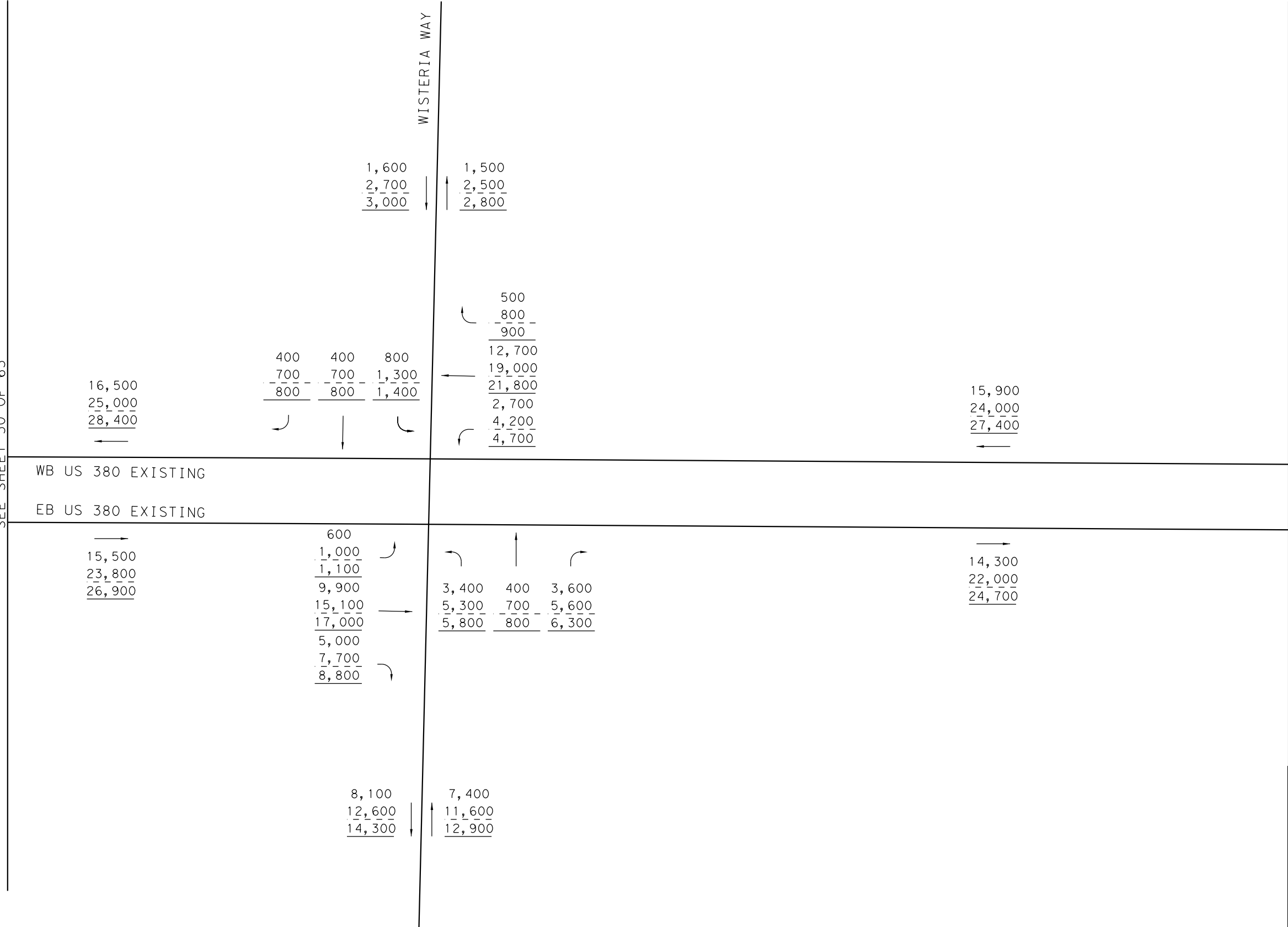
- XXXX- 2030 AVERAGE DAILY TRAFFIC VOLUMES
- XXXX- 2050 AVERAGE DAILY TRAFFIC VOLUMES
- XXXX- 2060 AVERAGE DAILY TRAFFIC VOLUMES

DATE: 7/13/2021
 FILE: US380_BLUE_TRF_50.dgn



SEE SHEET 50 OF 63

SEE SHEET 52 OF 63



WB US 380 EXISTING
EB US 380 EXISTING

NOT TO SCALE

NOT INTENDED FOR CONSTRUCTION,
BIDDING OR PERMIT PURPOSES
DHURVA LAHON, P.E.
SERIAL NUMBER 102185

EXISTING US 380 AND
WISTERIA WAY
AVERAGE DAILY TRAFFIC

Kimley»Horn
F-928

0135-02-065,
ETC. SHEET 51 OF 63

LEGEND

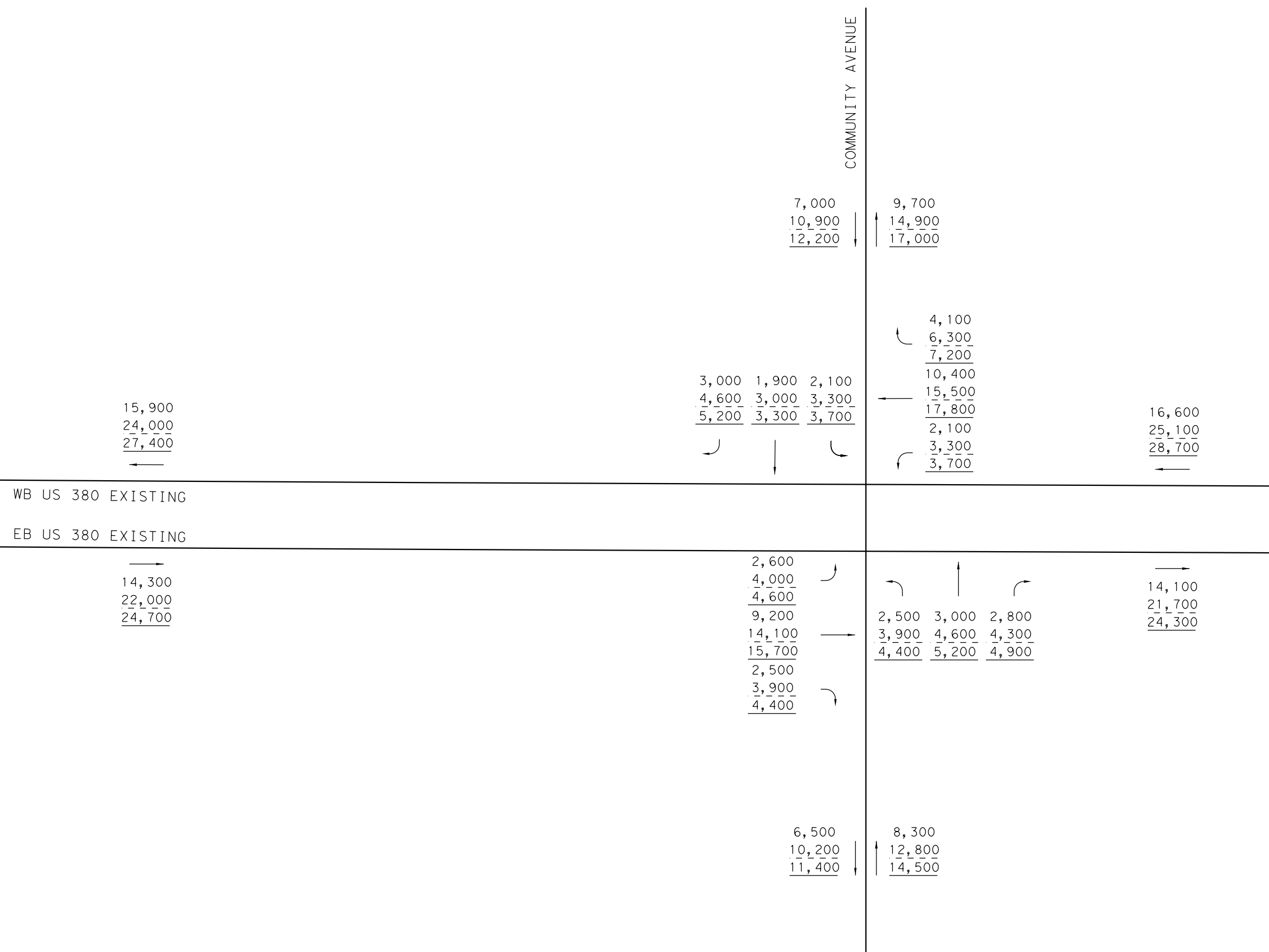
- XXXX- 2030 AVERAGE DAILY TRAFFIC VOLUMES
- XXXX- 2050 AVERAGE DAILY TRAFFIC VOLUMES
- XXXX- 2060 AVERAGE DAILY TRAFFIC VOLUMES

DATE: 7/13/2021
FILE: US380_BLUE_TRF_51.dgn



SEE SHEET 51 OF 63

SEE SHEET 53 OF 63



NOT TO SCALE

NOT INTENDED FOR CONSTRUCTION,
BIDDING OR PERMIT PURPOSES
DHURVA LAHON, P.E.
SERIAL NUMBER 102185

EXISTING US 380 AND
COMMUNITY AVE
AVERAGE DAILY TRAFFIC

Kimley»Horn
F-928

0135-02-065,
ETC. SHEET 52 OF 63

LEGEND

- XXXX- 2030 AVERAGE DAILY TRAFFIC VOLUMES
- XXXX- 2050 AVERAGE DAILY TRAFFIC VOLUMES
- XXXX- 2060 AVERAGE DAILY TRAFFIC VOLUMES

DATE: 7/13/2021
FILE: US380_BLUE_TRF_52.dgn



SEE SHEET 52 OF 63

SEE SHEET 54 OF 63

WB US 380 EXISTING
EB US 380 EXISTING

TOWNE CROSSING

16,600
25,100
28,700

2,600 400 1,500
4,000 700 2,300
4,600 800 2,600

4,500
7,000
8,000

3,000
4,800
5,400

200
400
500
11,700
17,500
20,100
1,400
2,200
2,500

13,300
20,100
23,100

14,100
21,700
24,300

2,000
3,100
3,500
10,900
16,700
18,700
1,200
1,900
2,100

2,300 800 800
3,600 1,300 1,300
4,000 1,400 1,400

13,200
20,300
22,700

3,000
4,800
5,400

3,900
6,200
6,800

NOT TO SCALE

NOT INTENDED FOR CONSTRUCTION,
BIDDING OR PERMIT PURPOSES
DHURVA LAHON, P.E.
SERIAL NUMBER 102185

EXISTING US 380 AND
TOWNE CROSSING
AVERAGE DAILY TRAFFIC

Kimley»Horn
F-928

0135-02-065,
ETC. SHEET 53 OF 63

LEGEND

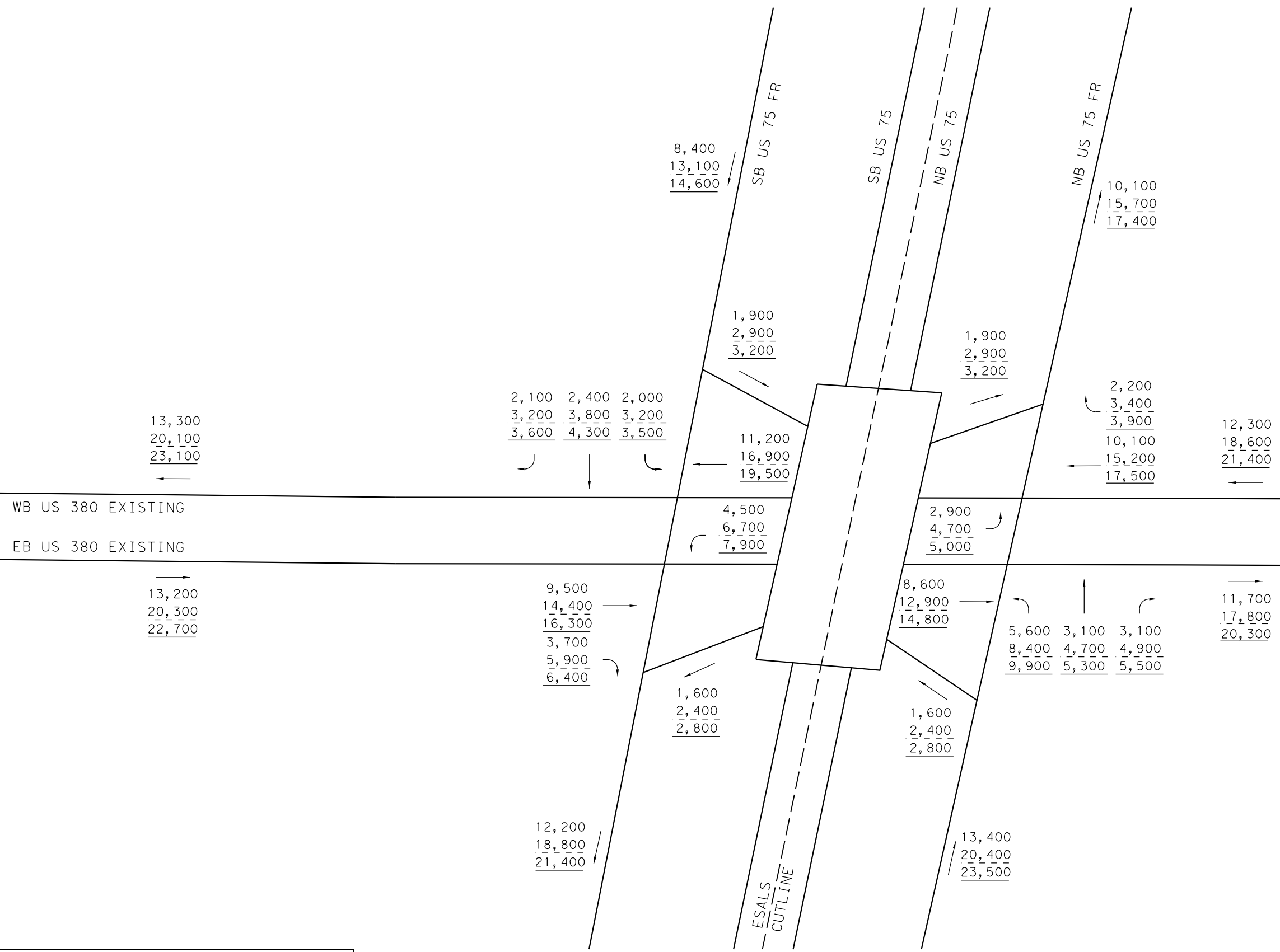
- XXXX- 2030 AVERAGE DAILY TRAFFIC VOLUMES
- XXXX- 2050 AVERAGE DAILY TRAFFIC VOLUMES
- XXXX- 2060 AVERAGE DAILY TRAFFIC VOLUMES

DATE: 7/13/2021
FILE: US380_BLUE_TRF_53.dgn



SEE SHEET 53 OF 63

SEE SHEET 55 OF 63



NOT TO SCALE

NOT INTENDED FOR CONSTRUCTION,
 BIDDING OR PERMIT PURPOSES
 DHRUVA LAHON, P.E.
 SERIAL NUMBER 102185

EXISTING US 380 AND
 US 75
 AVERAGE DAILY TRAFFIC

Kimley»Horn
F-928

0135-02-065, ETC. SHEET 54 OF 63

LEGEND

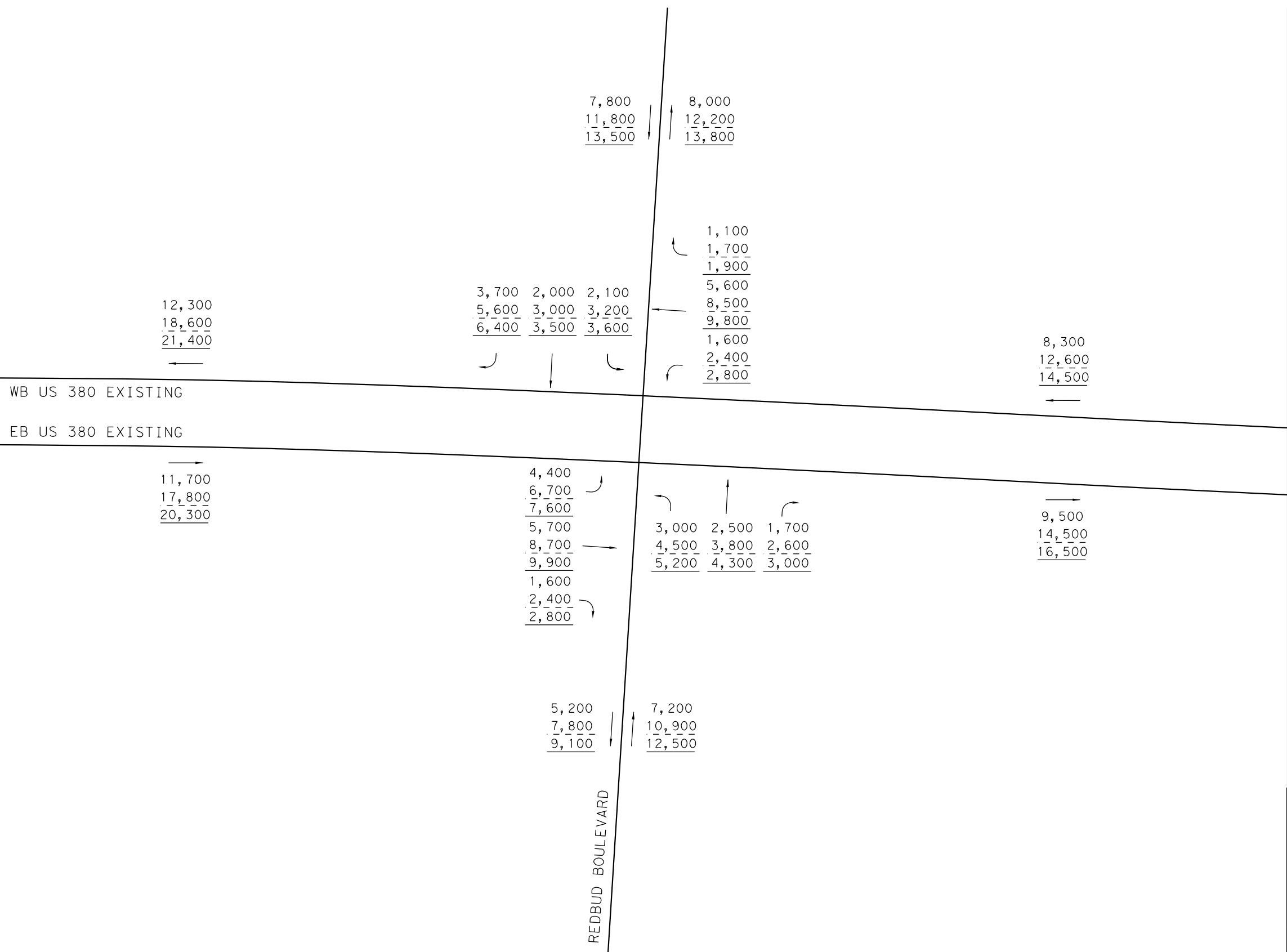
- XXXX- 2030 AVERAGE DAILY TRAFFIC VOLUMES
- XXXX- 2050 AVERAGE DAILY TRAFFIC VOLUMES
- XXXX- 2060 AVERAGE DAILY TRAFFIC VOLUMES

DATE: 7/13/2021
 FILE: US380_BLUE_TRF_54.dgn



SEE SHEET 54 OF 63

SEE SHEET 56 OF 63



WB US 380 EXISTING
EB US 380 EXISTING

REDBUD BOULEVARD

NOT TO SCALE

NOT INTENDED FOR CONSTRUCTION,
BIDDING OR PERMIT PURPOSES
DHURVA LAHON, P.E.
SERIAL NUMBER 102185

EXISTING US 380 AND
REDBUD BLVD
AVERAGE DAILY TRAFFIC

Kimley»Horn
F-928

0135-02-065,
ETC. SHEET 55 OF 63

LEGEND

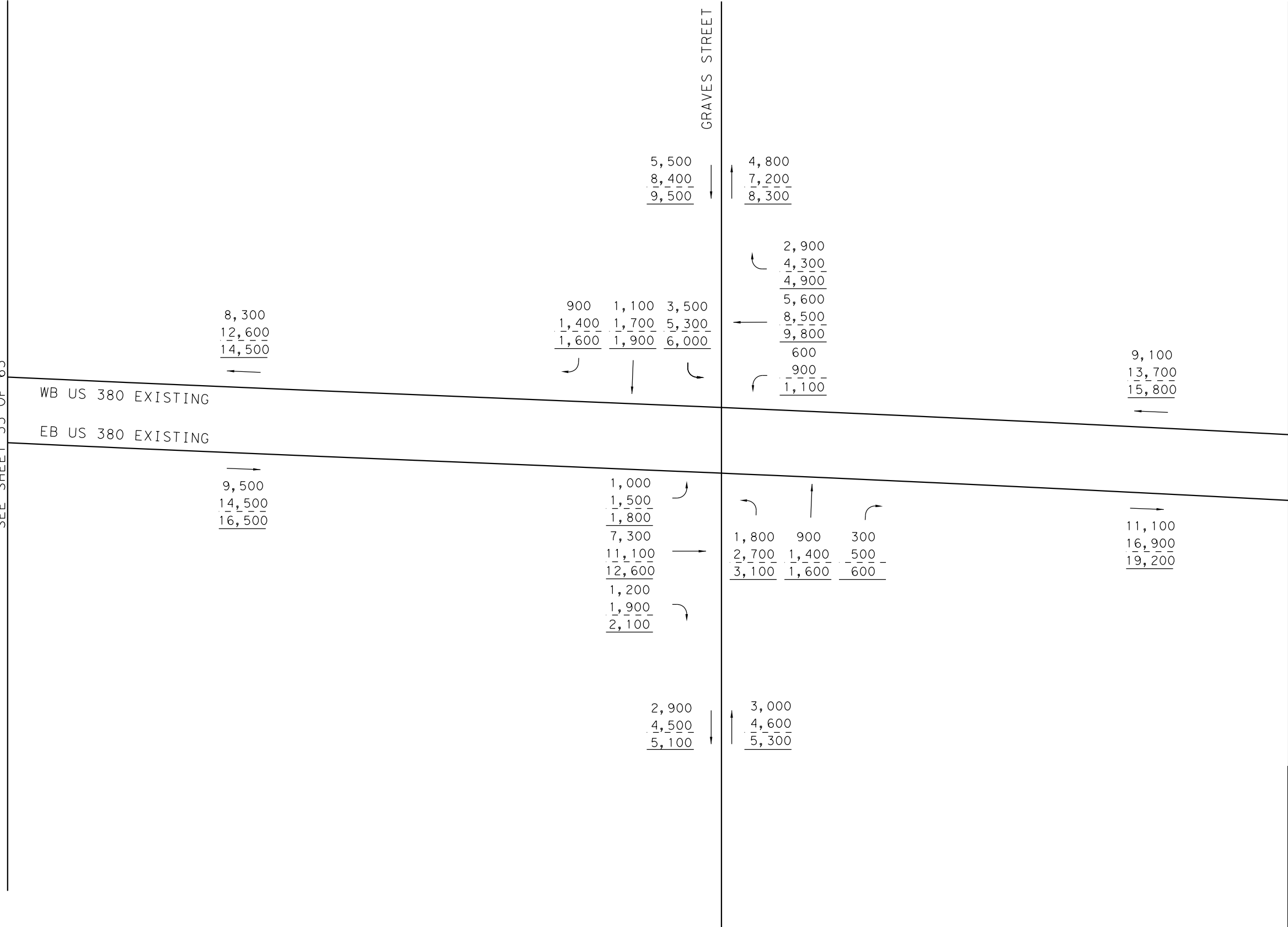
- XXXX- 2030 AVERAGE DAILY TRAFFIC VOLUMES
- XXXX- 2050 AVERAGE DAILY TRAFFIC VOLUMES
- XXXX- 2060 AVERAGE DAILY TRAFFIC VOLUMES

DATE: 7/13/2021
FILE: US380_BLUE_TRF_55.dgn



SEE SHEET 55 OF 63

SEE SHEET 57 OF 63



LEGEND

- XXXX- 2030 AVERAGE DAILY TRAFFIC VOLUMES
- XXXX- 2050 AVERAGE DAILY TRAFFIC VOLUMES
- XXXX- 2060 AVERAGE DAILY TRAFFIC VOLUMES

NOT TO SCALE

NOT INTENDED FOR CONSTRUCTION,
 BIDDING OR PERMIT PURPOSES
 DHRUVA LAHON, P.E.
 SERIAL NUMBER 102185

EXISTING US 380 AND
 GRAVES ST
 AVERAGE DAILY TRAFFIC





SEE SHEET 56 OF 63

SEE SHEET 58 OF 63

WB US 380 EXISTING

EB US 380 EXISTING

WADDILL STREET

9,100
13,700
15,800

200 200 600
300 300 900
400 400 1,100

1,000 600
1,500 900
1,900 1,200

200
300
400
8,200
12,300
14,100
900
1,400
1,600

9,300
14,000
16,100

11,100
16,900
19,200

200
300
400
9,800
14,900
16,900
1,100
1,700
1,900

700 200 1,300
1,100 300 2,000
1,300 400 2,300

11,700
17,800
20,300

2,200 2,200
3,400 3,400
3,900 4,000

NOT TO SCALE

NOT INTENDED FOR CONSTRUCTION,
BIDDING OR PERMIT PURPOSES
DHURVA LAHON, P.E.
SERIAL NUMBER 102185

EXISTING US 380 AND
WADDILL ST
AVERAGE DAILY TRAFFIC

Kimley»Horn
F-928

0135-02-065,
ETC. SHEET 57 OF 63

LEGEND

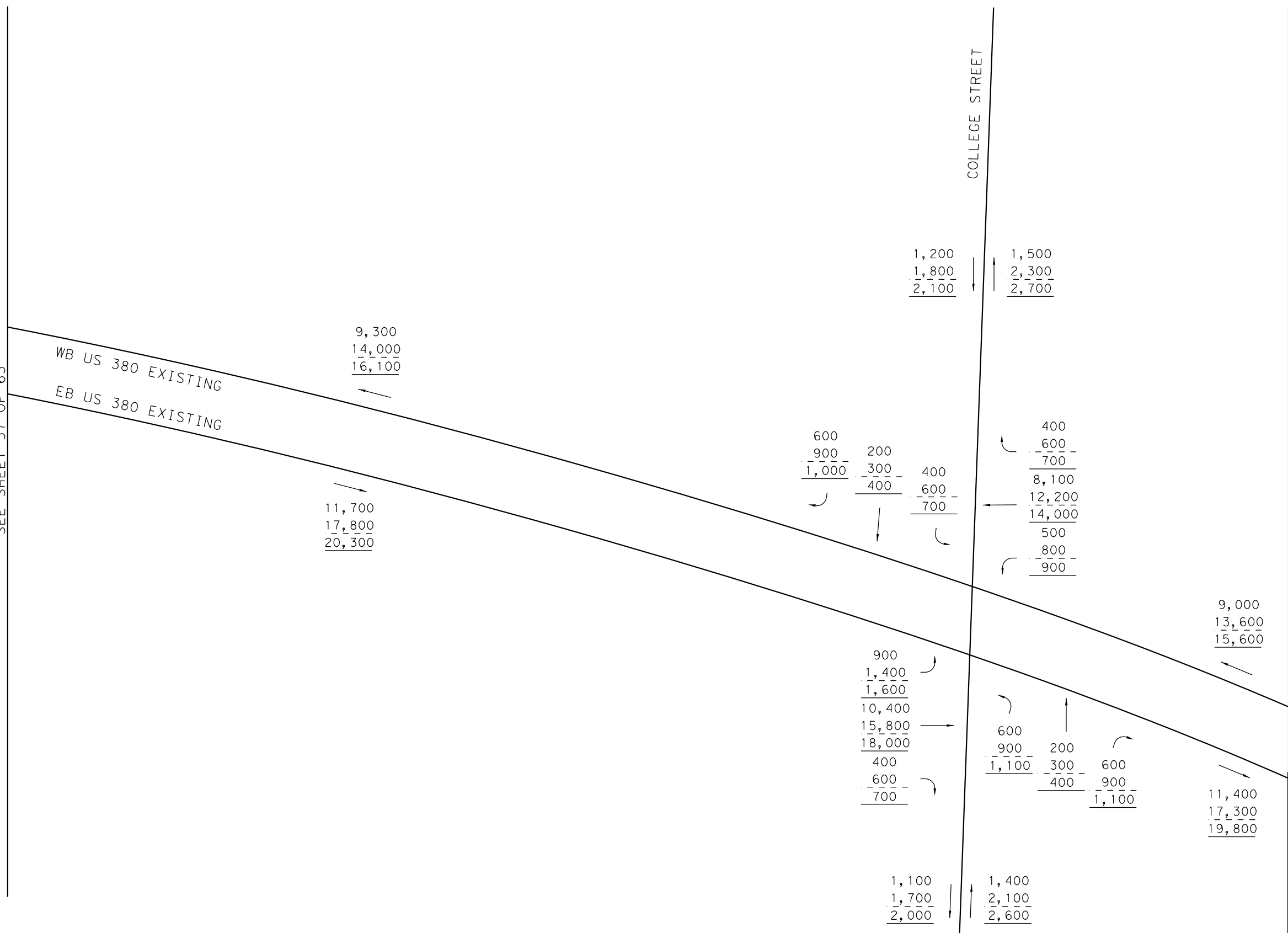
- XXXX- 2030 AVERAGE DAILY TRAFFIC VOLUMES
- XXXX- 2050 AVERAGE DAILY TRAFFIC VOLUMES
- XXXX- 2060 AVERAGE DAILY TRAFFIC VOLUMES

DATE: 7/13/2021
FILE: US380_BLUE_TRF_57.dgn



SEE SHEET 57 OF 63

SEE SHEET 59 OF 63



NOT TO SCALE

NOT INTENDED FOR CONSTRUCTION,
 BIDDING OR PERMIT PURPOSES
 DHRUVA LAHON, P.E.
 SERIAL NUMBER 102185

EXISTING US 380 AND
 COLLEGE ST
 AVERAGE DAILY TRAFFIC

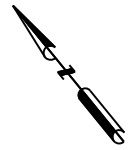
Kimley»Horn
F-928

0135-02-065,
 ETC. SHEET 58 OF 63

LEGEND

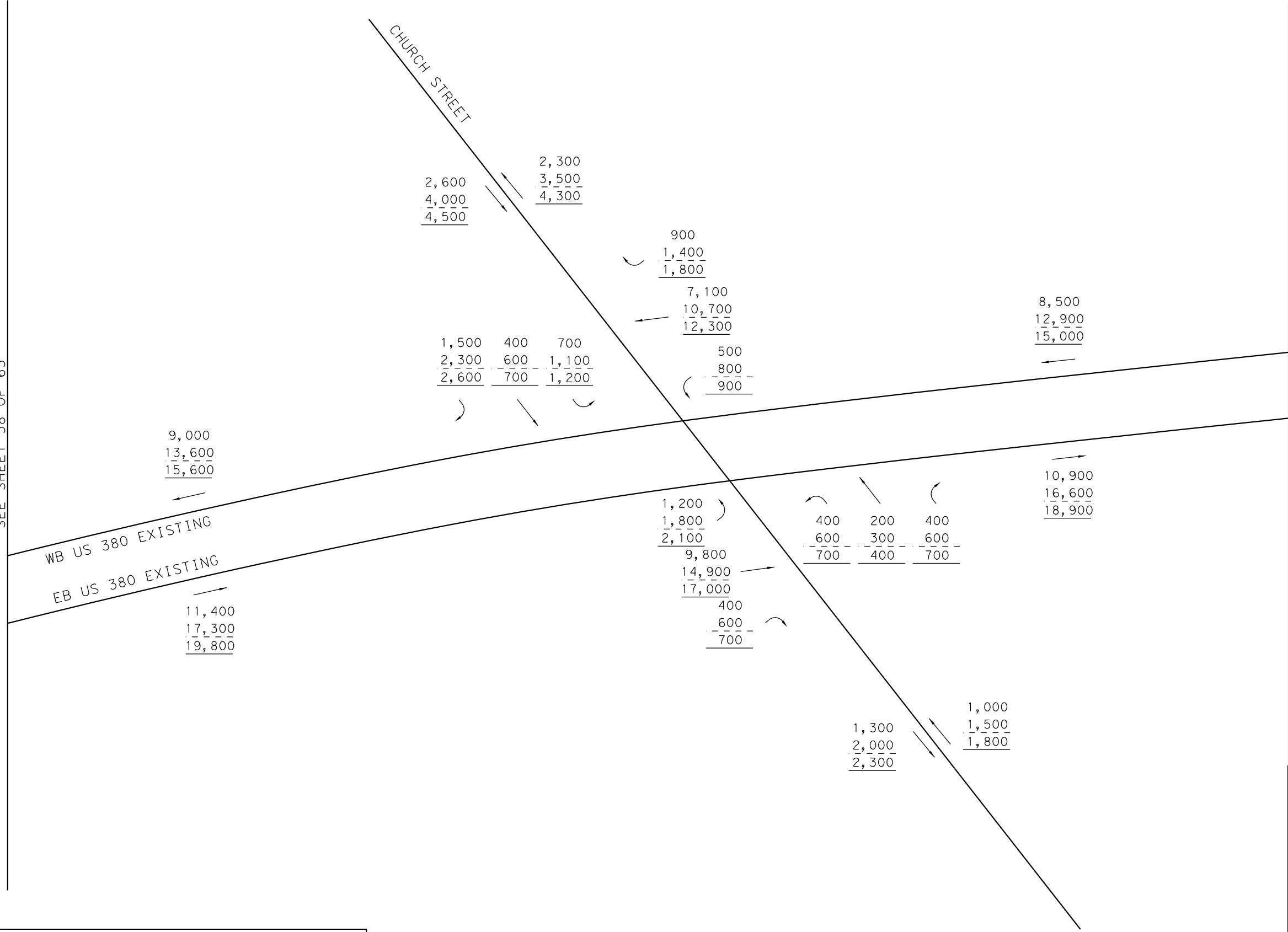
- XXXX- 2030 AVERAGE DAILY TRAFFIC VOLUMES
- XXXX- 2050 AVERAGE DAILY TRAFFIC VOLUMES
- XXXX- 2060 AVERAGE DAILY TRAFFIC VOLUMES

DATE: 7/13/2021
 FILE: US380_BLUE_TRF_58.dgn



SEE SHEET 58 OF 63

SEE SHEET 60 OF 63



WB US 380 EXISTING

EB US 380 EXISTING

CHURCH STREET

LEGEND

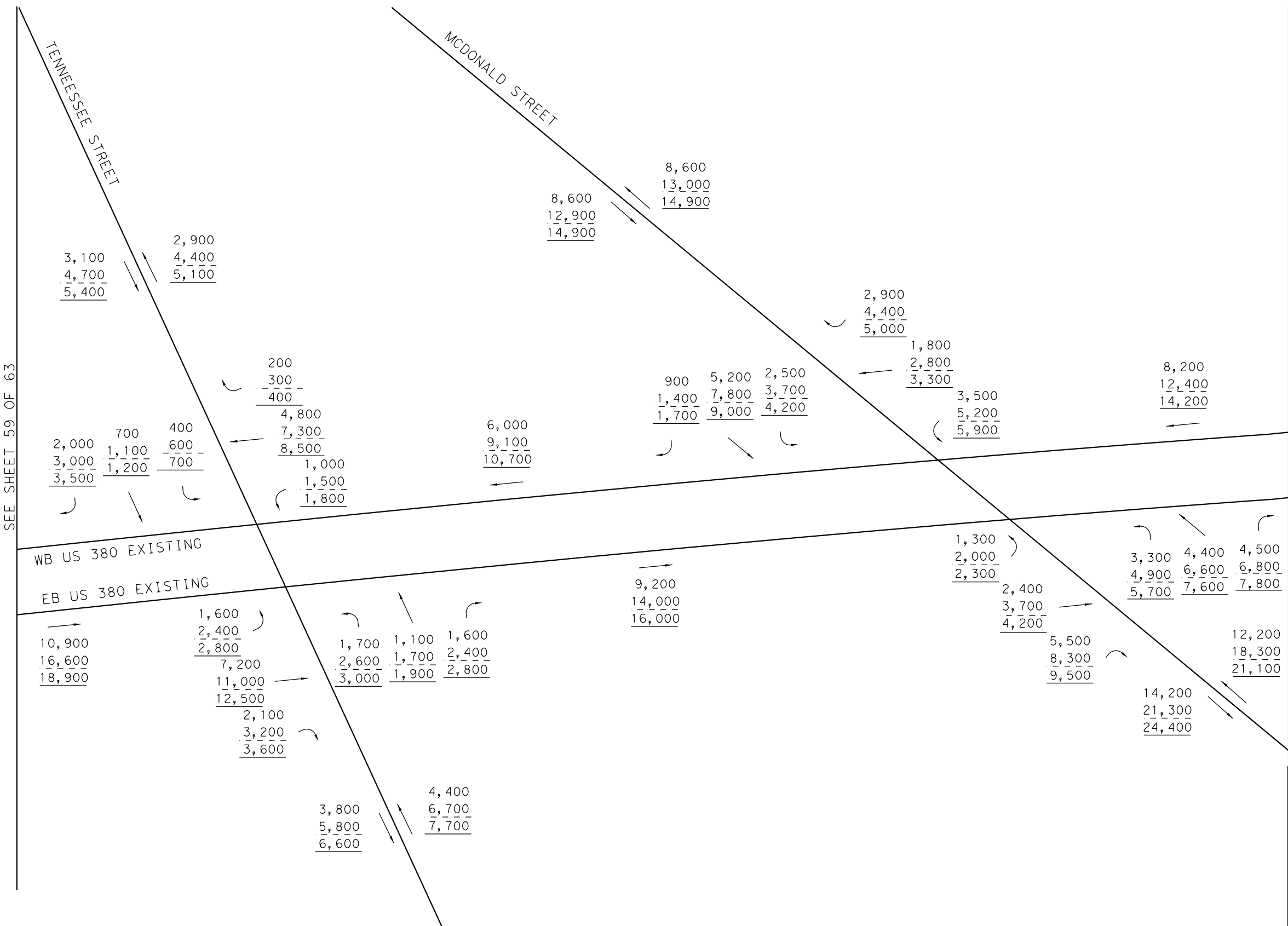
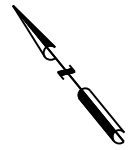
- XXXX- 2030 AVERAGE DAILY TRAFFIC VOLUMES
- XXXX- 2050 AVERAGE DAILY TRAFFIC VOLUMES
- XXXX- 2060 AVERAGE DAILY TRAFFIC VOLUMES

NOT TO SCALE

NOT INTENDED FOR CONSTRUCTION,
 BIDDING OR PERMIT PURPOSES
 DHRUVA LAHON, P.E.
 SERIAL NUMBER 102185

EXISTING US 380 AND CHURCH ST AVERAGE DAILY TRAFFIC





SEE SHEET 59 OF 63

SEE SHEET 61 OF 63

NOT TO SCALE

NOT INTENDED FOR CONSTRUCTION,
 BIDDING OR PERMIT PURPOSES
 DHRUVA LAHON, P.E.
 SERIAL NUMBER 102185

EXISTING US 380 AND
 MCDONALD ST/ SH 5
 AVERAGE DAILY TRAFFIC

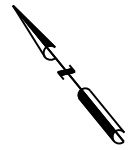
Kimley»Horn
F-928

0135-02-065,
 ETC. SHEET 60 OF 63

LEGEND

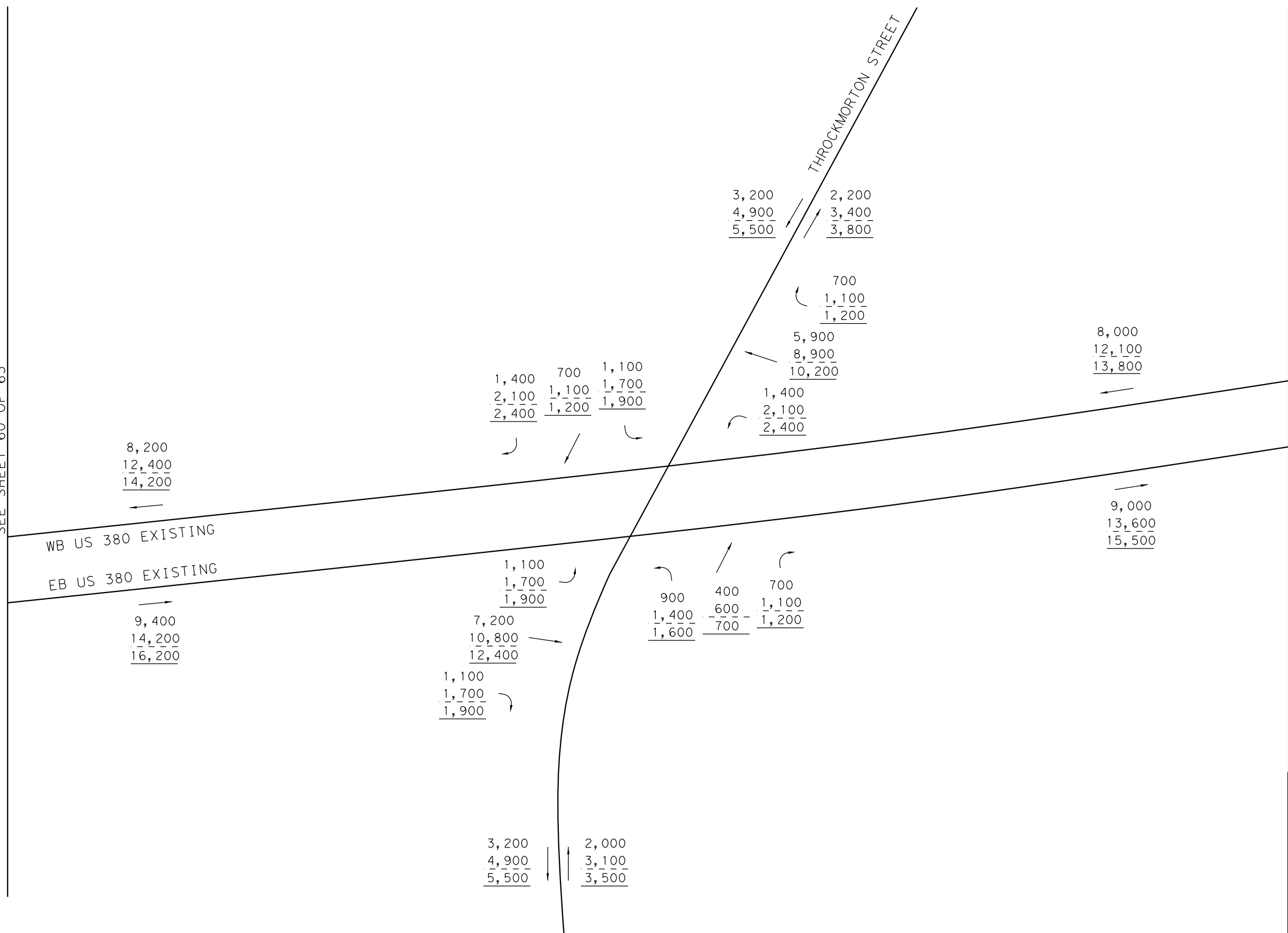
- XXXX- 2030 AVERAGE DAILY TRAFFIC VOLUMES
- XXXX- 2050 AVERAGE DAILY TRAFFIC VOLUMES
- XXXX- 2060 AVERAGE DAILY TRAFFIC VOLUMES

DATE: 7/13/2021
 FILE: US380_BLUE_TRF_60.dgn



SEE SHEET 60 OF 63

SEE SHEET 62 OF 63



NOT TO SCALE

NOT INTENDED FOR CONSTRUCTION,
 BIDDING OR PERMIT PURPOSES
 DHRUVA LAHON, P.E.
 SERIAL NUMBER 102185

EXISTING US 380 AND
 THROCKMORTON ST
 AVERAGE DAILY TRAFFIC

Kimley»Horn
F-928

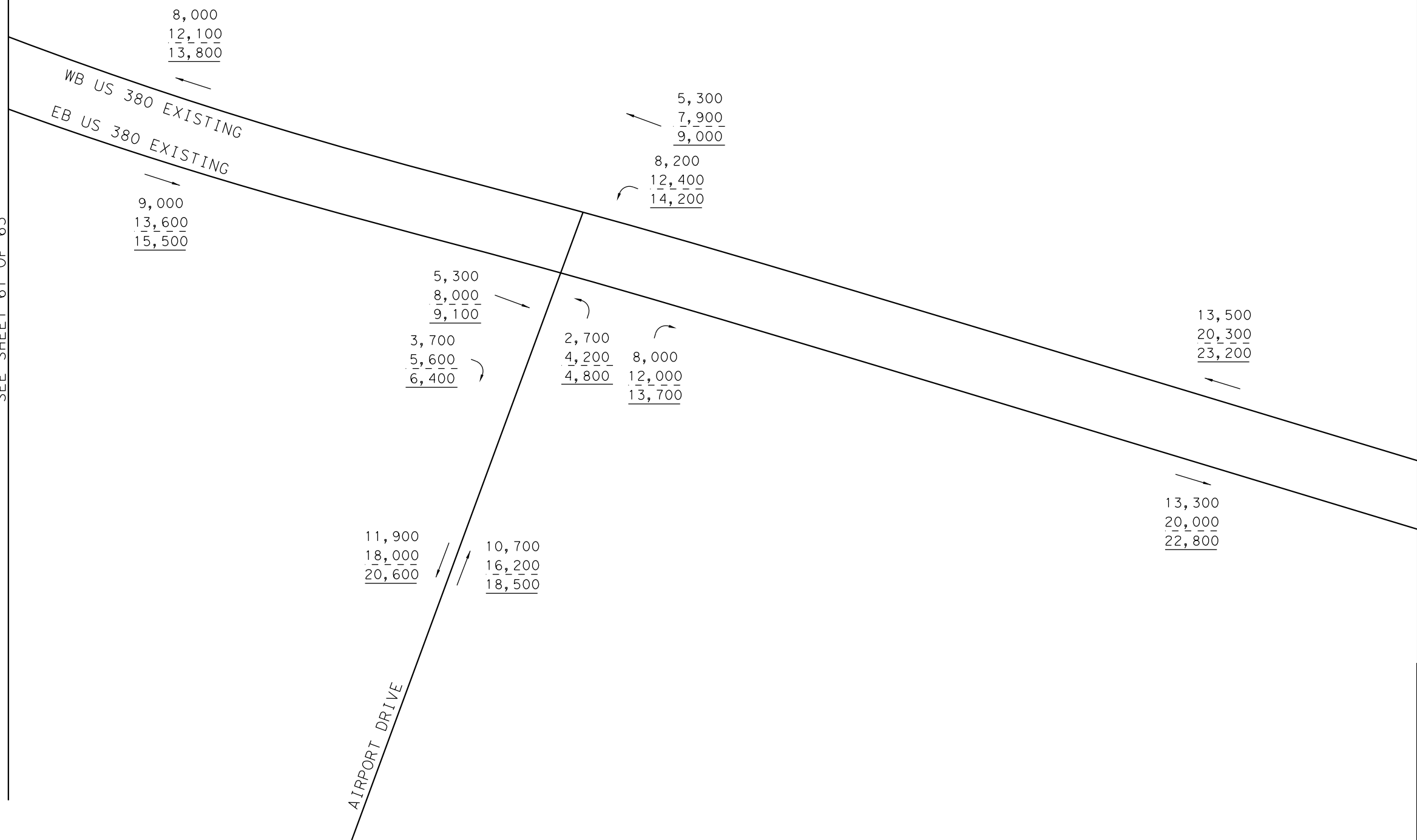
0135-02-065,
 ETC. SHEET 61 OF 63

DATE: 7/13/2021
 FILE: US380_BLUE_TRF_61.dgn



SEE SHEET 61 OF 63

SEE SHEET 63 OF 63



NOT TO SCALE

NOT INTENDED FOR CONSTRUCTION,
 BIDDING OR PERMIT PURPOSES
 DHRUVA LAHON, P.E.
 SERIAL NUMBER 102185

EXISTING US 380 AND
 AIRPORT DR
 AVERAGE DAILY TRAFFIC



0135-02-065,
 ETC. SHEET 62 OF 63

LEGEND

- XXXX- 2030 AVERAGE DAILY TRAFFIC VOLUMES
- XXXX- 2050 AVERAGE DAILY TRAFFIC VOLUMES
- XXXX- 2060 AVERAGE DAILY TRAFFIC VOLUMES

DATE: 7/13/2021
 FILE: US380_BLUE_TRF_62.dgn



SEE SHEET 45 OF 63

13,500		13,300
<u>20,300</u>	↙ ↘	<u>20,000</u>
<u>23,200</u>		<u>22,800</u>

SEE SHEET 62 OF 63

13,500
<u>20,300</u>
<u>23,200</u>

↙
WB US 380 EXISTING
↘
EB US 380 EXISTING

13,300
<u>20,000</u>
<u>22,800</u>

NOT TO SCALE

NOT INTENDED FOR CONSTRUCTION,
BIDDING OR PERMIT PURPOSES
DHURVA LAHON, P.E.
SERIAL NUMBER 102185

EXISTING US 380 AND
NEW HOPE ROAD/ FM 1827
AVERAGE DAILY TRAFFIC

Kimley»Horn
F-928

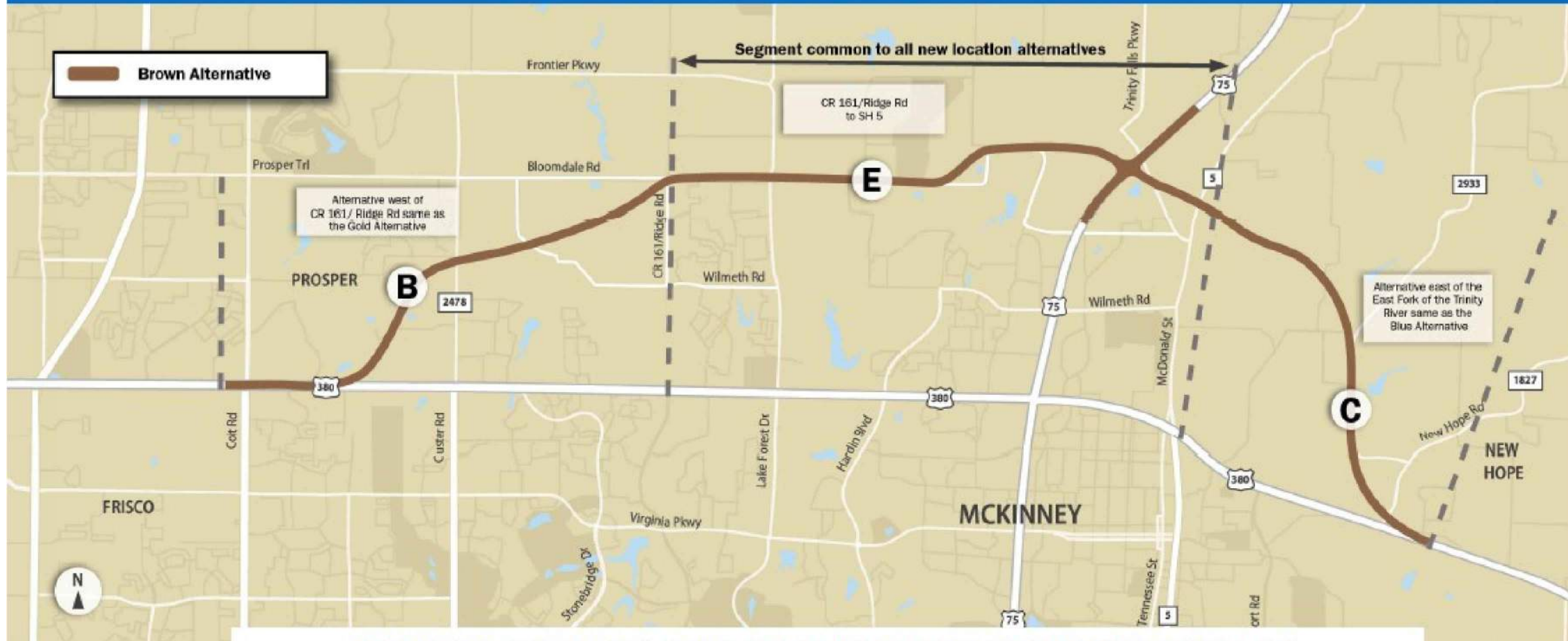
0135-02-065,
ETC. SHEET 63 OF 63

LEGEND

- XXXX- 2030 AVERAGE DAILY TRAFFIC VOLUMES
- XXXX- 2050 AVERAGE DAILY TRAFFIC VOLUMES
- XXXX- 2060 AVERAGE DAILY TRAFFIC VOLUMES

DATE: 7/13/2021
FILE: US380_BLUE_TRF_63.dgn

Brown Build Alternative – New Location



Brown Alternative

Alternative west of CR 161/ Ridge Rd same as the Gold Alternative

CR 161/Ridge Rd to SH 5

Alternative east of the East Fork of the Trinity River same as the Blue Alternative

Modifications may continue to be made to the alternatives as the project progresses.

NOT TO SCALE

NOT INTENDED FOR CONSTRUCTION,
BIDDING OR PERMIT PURPOSES
DHURVA LAHON, P.E.
SERIAL NUMBER 102185

US 380 BROWN ALT
KEYMAP

Kimley»Horn
F-928

0135-02-065,
ETC.

SHEET 1 OF 1



COIT ROAD

12,200
18,800
21,300

11,800
18,400
20,800

47,800
73,100
83,000

WB US 380

3,800 4,300 4,100
5,900 6,500 6,400
6,700 7,100 7,500

3,900
6,200
7,000
39,600
60,400
68,500
3,500
5,500
6,700

47,000
72,100
82,200
WB US 380

EB US 380
46,300
71,400
80,500

3,900
6,100
7,000
38,400
59,100
66,500
4,000
6,200
7,000

4,400 4,000 3,500
6,800 6,100 5,300
7,800 6,800 6,300

EB US 380
46,000
70,800
80,300

11,800
18,200
20,800

11,900
18,200
20,900

SEE SHEET 2 OF 62

NOT TO SCALE

NOT INTENDED FOR CONSTRUCTION,
BIDDING OR PERMIT PURPOSES
DHURVA LAHON, P.E.
SERIAL NUMBER 102185

US 380 BROWN ALT AND
COIT RD
AVERAGE DAILY TRAFFIC
BROWN ALT BUILD VOLUMES

Kimley»Horn
F-928

0135-02-065,
ETC. SHEET 1 OF 62

LEGEND

- XXXX- 2030 AVERAGE DAILY TRAFFIC VOLUMES
- XXXX- 2050 AVERAGE DAILY TRAFFIC VOLUMES
- XXXX- 2060 AVERAGE DAILY TRAFFIC VOLUMES

DATE: 7/13/2021
FILE: US380_BROWN_TRF_01.dgn



SEE SHEET 1 OF 62

SEE SHEET 3 OF 62

47,000
72,100
82,200
←
WB US 380

→
EB US 380
46,000
70,800
80,300

ENTRANCE FROM INDEPENDENCE PARKWAY
47,000
72,100
82,200

EXIT TO INDEPENDENCE PARKWAY
46,000
70,800
80,300

47,000
72,100
82,200
←
WB US 380

→
EB US 380
46,000
70,800
80,300

NOT TO SCALE

NOT INTENDED FOR CONSTRUCTION,
BIDDING OR PERMIT PURPOSES
DHURVA LAHON, P.E.
SERIAL NUMBER 102185

US 380 BROWN ALT AND
RAMPS
AVERAGE DAILY TRAFFIC
BROWN ALT BUILD VOLUMES

Kimley»Horn
F-928

0135-02-065,
ETC. SHEET 2 OF 62

LEGEND

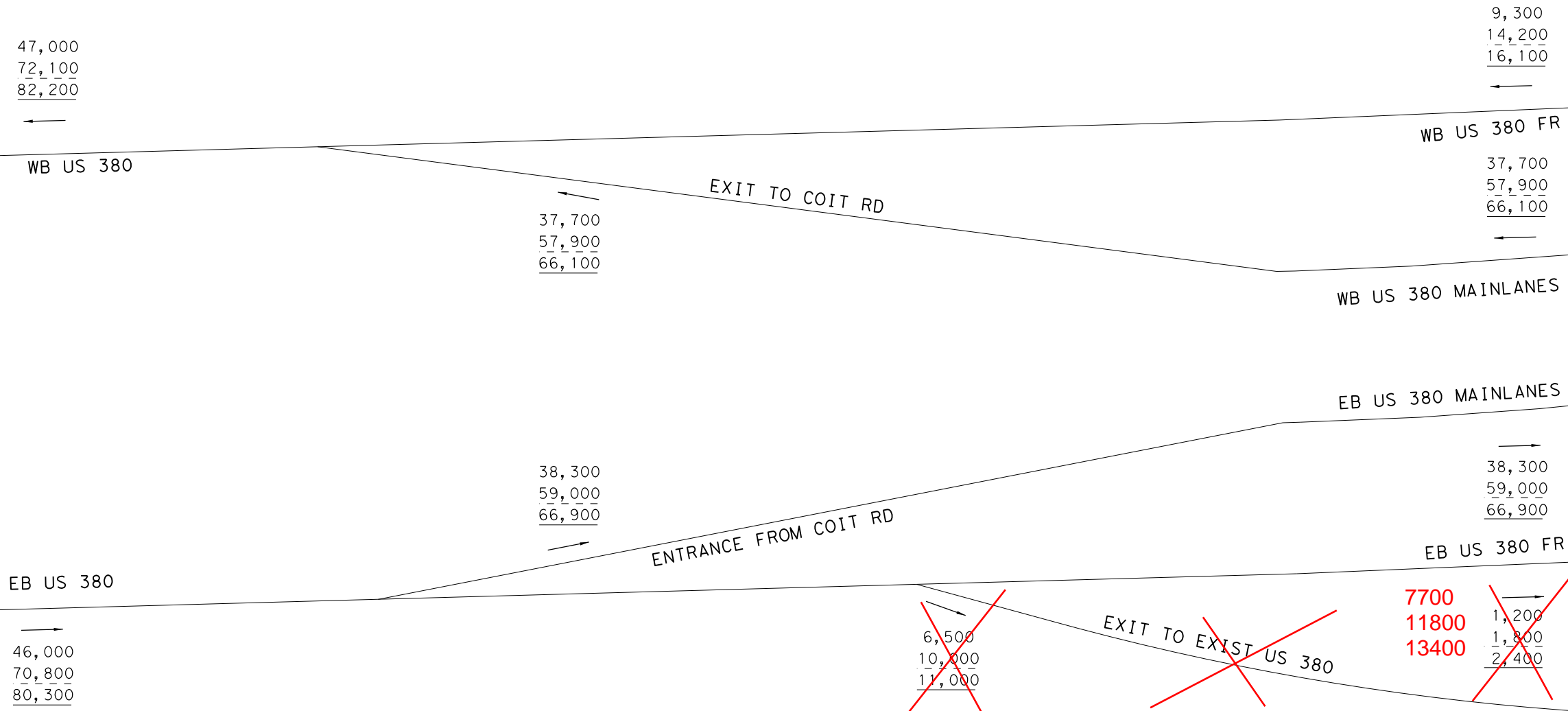
- XXXX- 2030 AVERAGE DAILY TRAFFIC VOLUMES
- XXXX- 2050 AVERAGE DAILY TRAFFIC VOLUMES
- XXXX- 2060 AVERAGE DAILY TRAFFIC VOLUMES

DATE: 7/13/2021
FILE: US380_BROWN_TRF_02.dgn



SEE SHEET 2 OF 62

SEE SHEET 4 OF 62



NOT TO SCALE

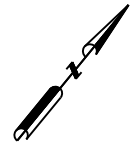
NOT INTENDED FOR CONSTRUCTION,
 BIDDING OR PERMIT PURPOSES
 DHRUVA LAHON, P.E.
 SERIAL NUMBER 102185

US 380 BROWN ALT AND
 RAMPS
 AVERAGE DAILY TRAFFIC
 BROWN ALT BUILD VOLUMES



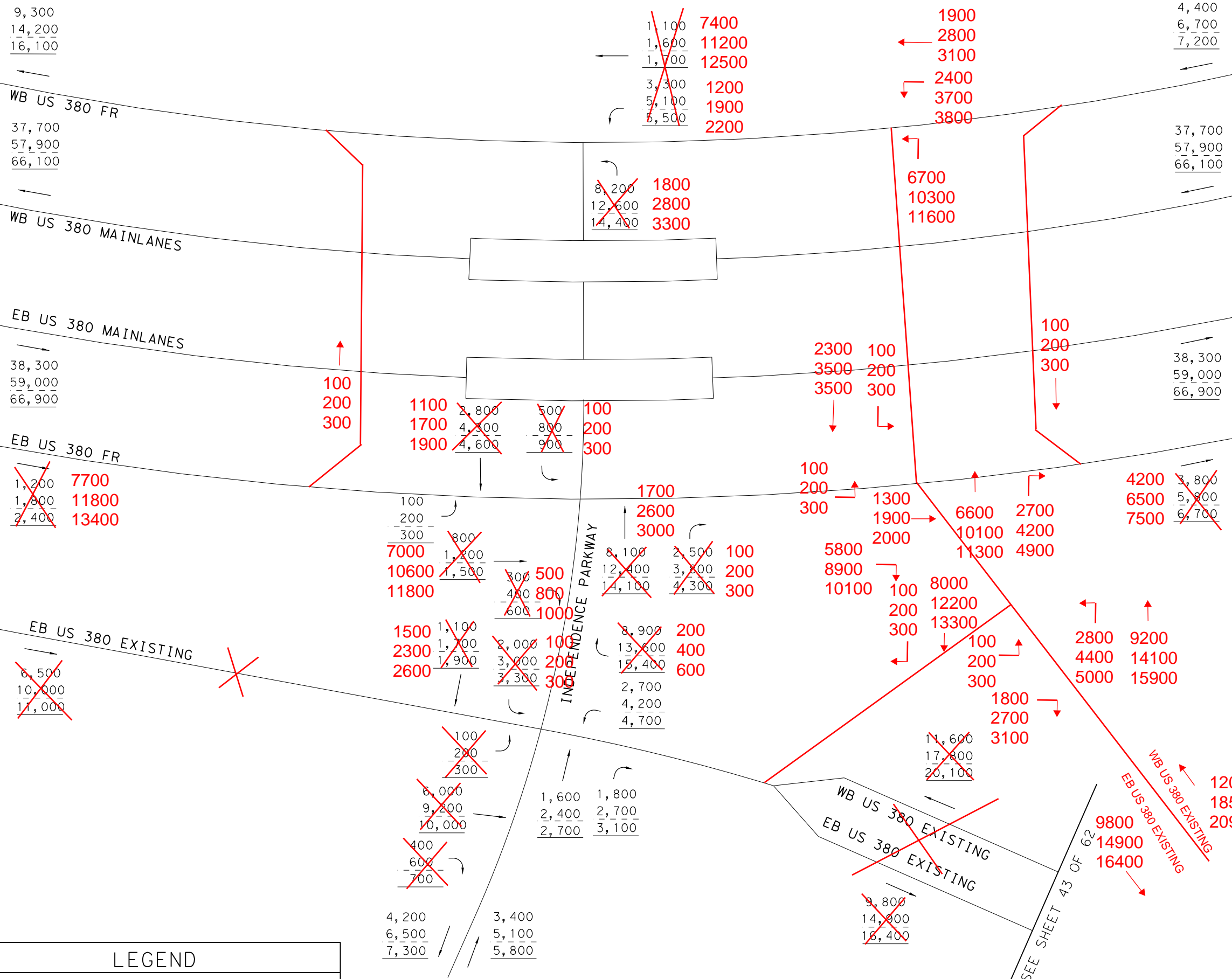
LEGEND

- XXXX- 2030 AVERAGE DAILY TRAFFIC VOLUMES
- XXXX- 2050 AVERAGE DAILY TRAFFIC VOLUMES
- XXXX- 2060 AVERAGE DAILY TRAFFIC VOLUMES



SEE SHEET 3 OF 62

SEE SHEET 5 OF 62



LEGEND

- XXXX- 2030 AVERAGE DAILY TRAFFIC VOLUMES
- XXXX- 2050 AVERAGE DAILY TRAFFIC VOLUMES
- XXXX- 2060 AVERAGE DAILY TRAFFIC VOLUMES

NOT TO SCALE

NOT INTENDED FOR CONSTRUCTION,
 BIDDING OR PERMIT PURPOSES
 DHRUVA LAHON, P.E.
 SERIAL NUMBER 102185

US 380 BROWN ALT AND
 INDEPENDENCE PKWY
 AVERAGE DAILY TRAFFIC
 BROWN ALT BUILD VOLUMES



DATE: 7/13/2021
 FILE: US380_BROWN_TRF_04.dgn



SEE SHEET 4 OF 62

4,400
6,700
7,200

WB US 380 FR

37,700
57,900
66,100

ENTRANCE FROM N CUSTER RD (FM 4278)

6,700
10,400
11,800

WB US 380 MAINLANES

11,100
17,100
19,000

EB US 380 MAINLANES

38,300
59,000
66,900

7,000
10,800
12,200

EXIT TO N CUSTER RD (FM 2478)

31,000
47,500
54,300

EB US 380 FR

~~3,800~~ 4200
~~5,800~~ 6500
~~6,700~~ 7500

31,300
48,200
54,700

11200
17300
19700

~~10,800~~
~~16,600~~
~~18,900~~

SEE SHEET 6 OF 62

NOT TO SCALE

NOT INTENDED FOR CONSTRUCTION,
BIDDING OR PERMIT PURPOSES
DHURVA LAHON, P.E.
SERIAL NUMBER 102185

US 380 BROWN ALT AND
RAMPS
AVERAGE DAILY TRAFFIC
BROWN ALT BUILD VOLUMES



0135-02-065,
ETC. SHEET 5 OF 62

LEGEND

- XXXX- 2030 AVERAGE DAILY TRAFFIC VOLUMES
- XXXX- 2050 AVERAGE DAILY TRAFFIC VOLUMES
- XXXX- 2060 AVERAGE DAILY TRAFFIC VOLUMES

DATE: 7/13/2021
FILE: US380_BROWN_TRF_05.dgn



SEE SHEET 5 OF 62

SEE SHEET 7 OF 62

11,100
17,100
19,000

WB US 380 FR

31,000
47,500
54,300

WB US 380 MAINLANES

EB US 380 MAINLANES

31,300
48,200
54,700

EB US 380 FR

~~10,800~~ 11200
~~16,600~~ 17300
~~18,900~~ 19700

4,200
6,500
7,200

ENTRANCE FROM INDEPENDENCE PARKWAY

4,200
6,500
7,300

EXIT TO INDEPENDENCE PARKWAY

6,900
10,600
11,700

35,200
54,000
61,600

35,500
54,700
61,900

7000
10800
12500

~~8,600~~
~~10,100~~
~~11,700~~

NOT TO SCALE

NOT INTENDED FOR CONSTRUCTION,
BIDDING OR PERMIT PURPOSES
DHURVA LAHON, P.E.
SERIAL NUMBER 102185

US 380 BROWN ALT AND
RAMPS
AVERAGE DAILY TRAFFIC
BROWN ALT BUILD VOLUMES

Kimley»Horn
F-928

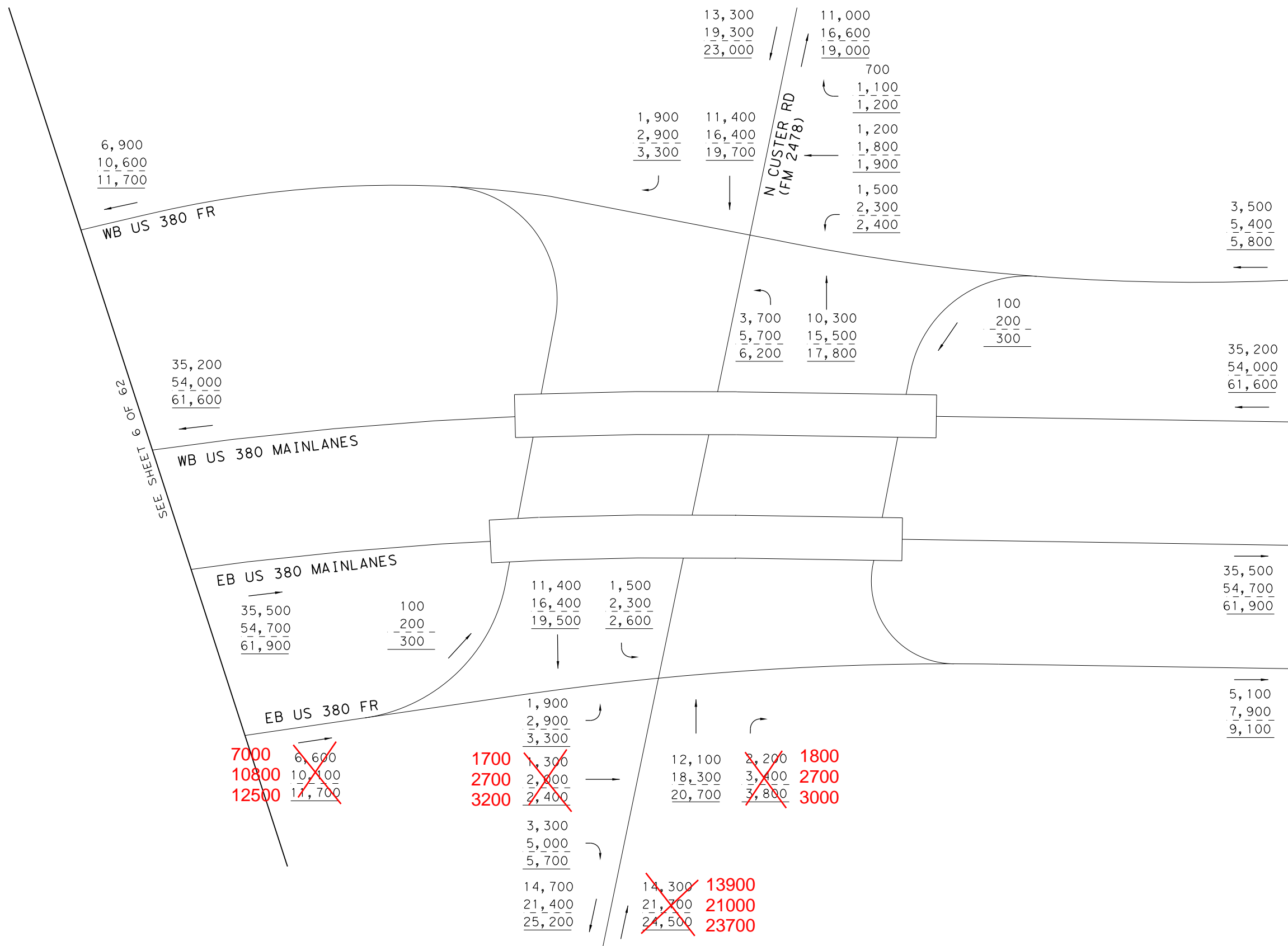
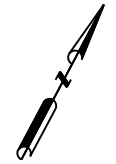
0135-02-065,
ETC.

SHEET 6 OF 62

LEGEND

- XXXX- 2030 AVERAGE DAILY TRAFFIC VOLUMES
- XXXX- 2050 AVERAGE DAILY TRAFFIC VOLUMES
- XXXX- 2060 AVERAGE DAILY TRAFFIC VOLUMES

DATE: 7/13/2021
FILE: US380_BROWN_TRF_06.dgn



6,900
10,600
11,700

WB US 380 FR

SEE SHEET 6 OF 62

35,200
54,000
61,600

WB US 380 MAINLANES

EB US 380 MAINLANES

35,500
54,700
61,900

EB US 380 FR

~~6,600~~
~~10,100~~
~~17,700~~
7000
10800
12500

1,900
2,900
3,300

13,300
19,300
23,000

N CUSTER RD
(FM 2478)

11,000
16,600
19,000

700
1,100
1,200
1,200
1,800
1,900
1,500
2,300
2,400

3,700
5,700
6,200

10,300
15,500
17,800

100
200
300

3,500
5,400
5,800

35,200
54,000
61,600

35,500
54,700
61,900

5,100
7,900
9,100

~~1,300~~
~~2,800~~
~~2,400~~
1700
2700
3200

3,300
5,000
5,700

14,700
21,400
25,200

12,100
18,300
20,700

~~14,300~~
~~21,700~~
~~24,500~~
13900
21000
23700

~~2,200~~
~~3,400~~
~~3,800~~
1800
2700
3000

SEE SHEET 8 OF 62

NOT TO SCALE

NOT INTENDED FOR CONSTRUCTION,
BIDDING OR PERMIT PURPOSES
DHURVA LAHON, P.E.
SERIAL NUMBER 102185

US 380 BROWN ALT AND
FM 2478
AVERAGE DAILY TRAFFIC
BROWN ALT BUILD VOLUMES

Kimley»Horn
F-928

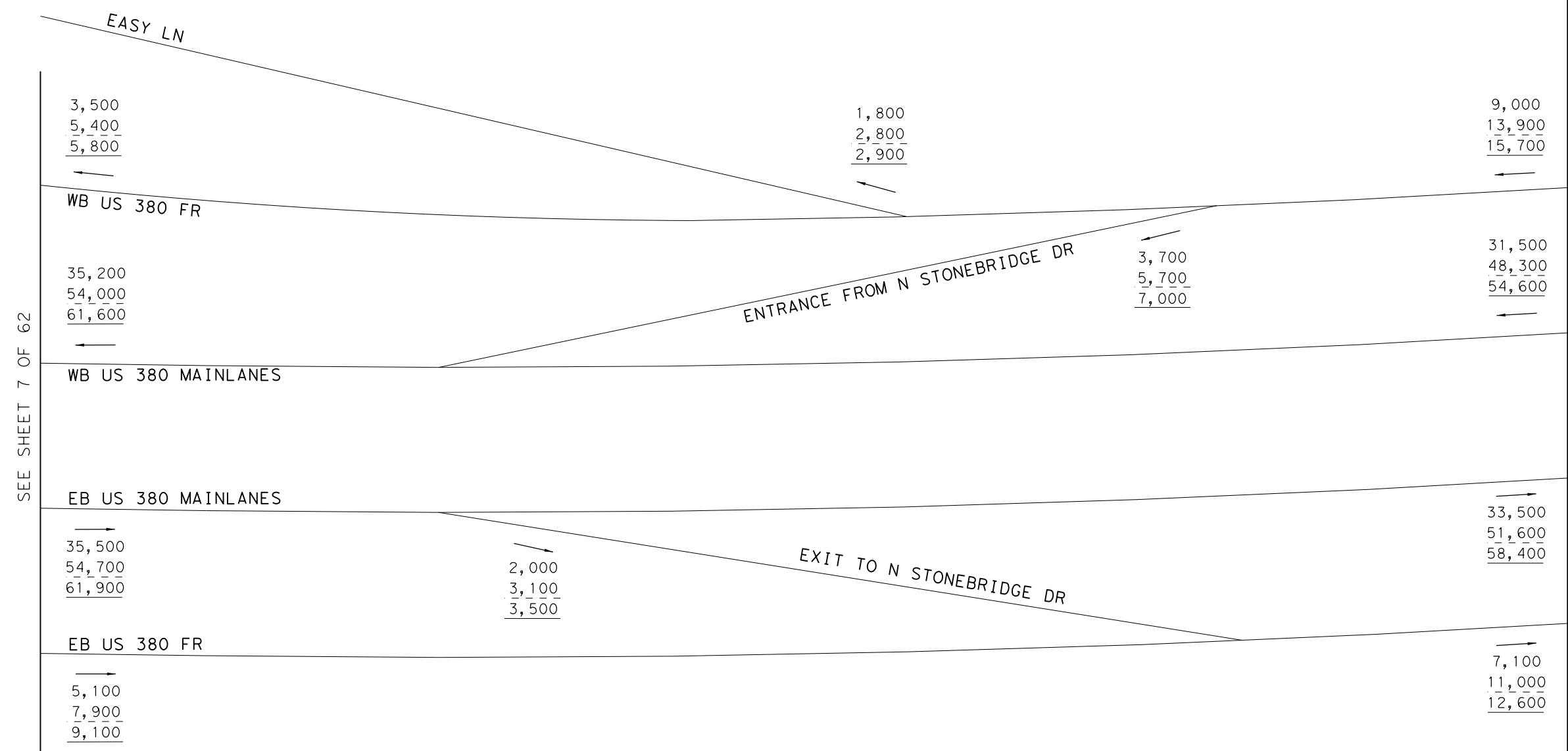
0135-02-065,
ETC.

SHEET 7 OF 62

LEGEND

- XXXX- 2030 AVERAGE DAILY TRAFFIC VOLUMES
- XXXX- 2050 AVERAGE DAILY TRAFFIC VOLUMES
- XXXX- 2060 AVERAGE DAILY TRAFFIC VOLUMES

DATE: 7/13/2021
FILE: US380_BROWN_TRF_07.dgn



SEE SHEET 7 OF 62

SEE SHEET 9 OF 62

NOT TO SCALE

NOT INTENDED FOR CONSTRUCTION,
 BIDDING OR PERMIT PURPOSES
 DHRUVA LAHON, P.E.
 SERIAL NUMBER 102185

US 380 BROWN ALT AND
 RAMPS
 AVERAGE DAILY TRAFFIC
 BROWN ALT BUILD VOLUMES



LEGEND

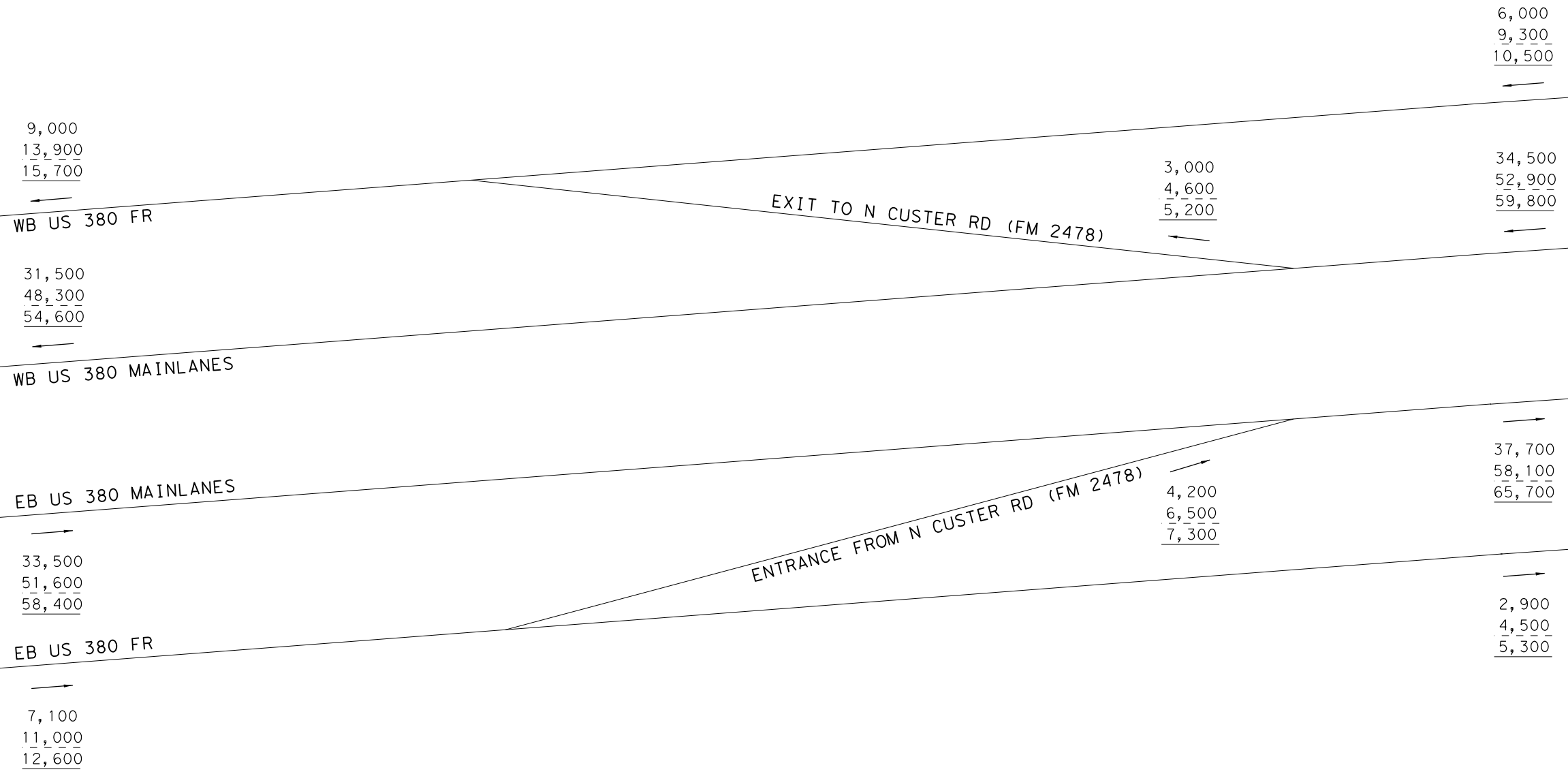
- XXXX- 2030 AVERAGE DAILY TRAFFIC VOLUMES
- XXXX- 2050 AVERAGE DAILY TRAFFIC VOLUMES
- XXXX- 2060 AVERAGE DAILY TRAFFIC VOLUMES

DATE: 7/13/2021
 FILE: US380_BROWN_TRF_08.dgn



SEE SHEET 8 OF 62

SEE SHEET 10 OF 62



NOT TO SCALE

NOT INTENDED FOR CONSTRUCTION,
 BIDDING OR PERMIT PURPOSES
 DHRUVA LAHON, P.E.
 SERIAL NUMBER 102185

US 380 BROWN ALT AND
 RAMPS
 AVERAGE DAILY TRAFFIC
 BROWN ALT BUILD VOLUMES

Kimley»Horn
F-928

0135-02-065,
 ETC.

SHEET 9 OF 62

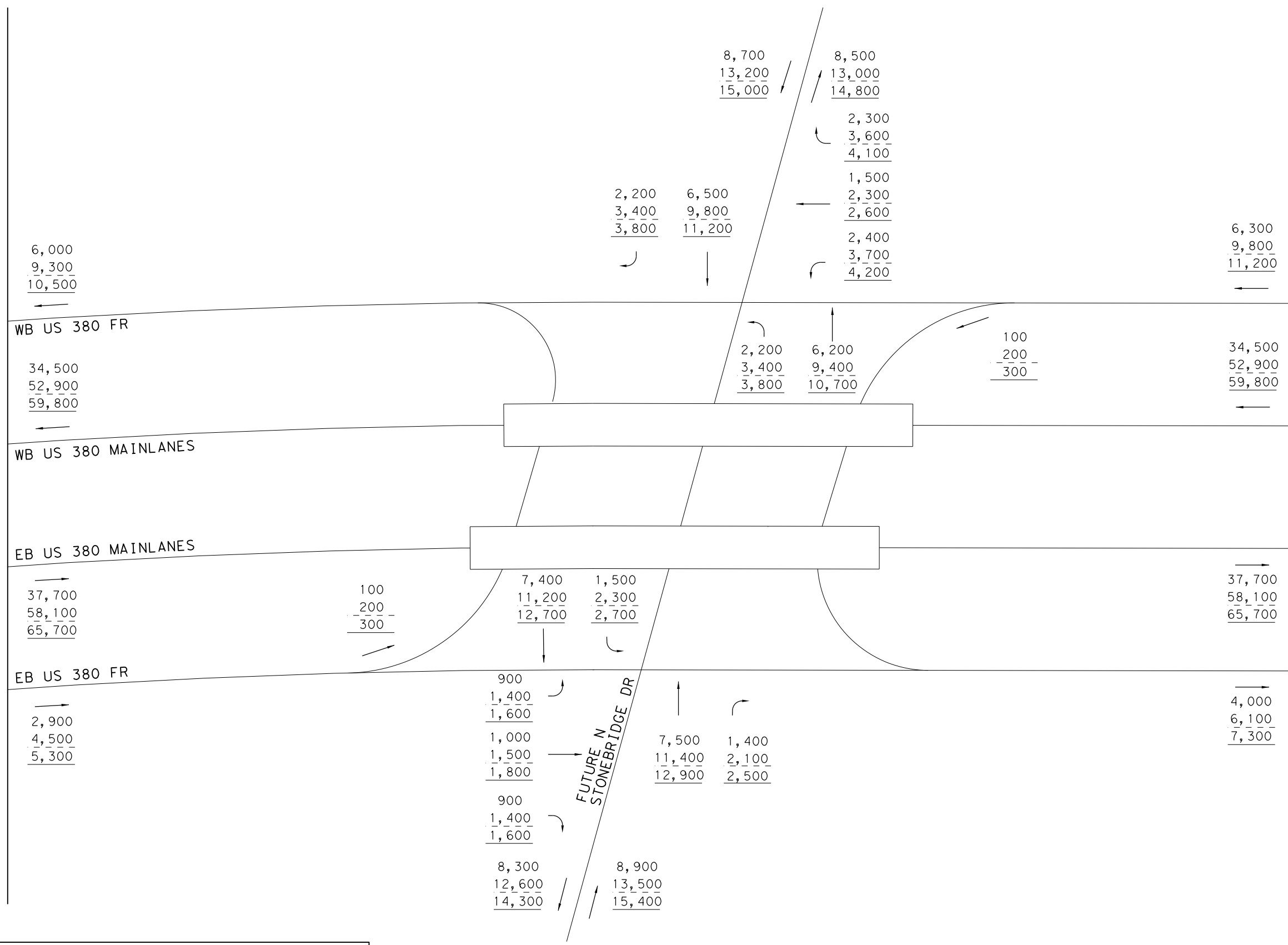
LEGEND

- XXXX- 2030 AVERAGE DAILY TRAFFIC VOLUMES
- XXXX- 2050 AVERAGE DAILY TRAFFIC VOLUMES
- XXXX- 2060 AVERAGE DAILY TRAFFIC VOLUMES



SEE SHEET 9 OF 62

SEE SHEET 11 OF 62



LEGEND

- XXXX- 2030 AVERAGE DAILY TRAFFIC VOLUMES
- XXXX- 2050 AVERAGE DAILY TRAFFIC VOLUMES
- XXXX- 2060 AVERAGE DAILY TRAFFIC VOLUMES

NOT TO SCALE

NOT INTENDED FOR CONSTRUCTION,
 BIDDING OR PERMIT PURPOSES
 DHRUVA LAHON, P.E.
 SERIAL NUMBER 102185

US 380 BROWN ALT AND
 CR 124
 AVERAGE DAILY TRAFFIC
 BROWN ALT BUILD VOLUMES

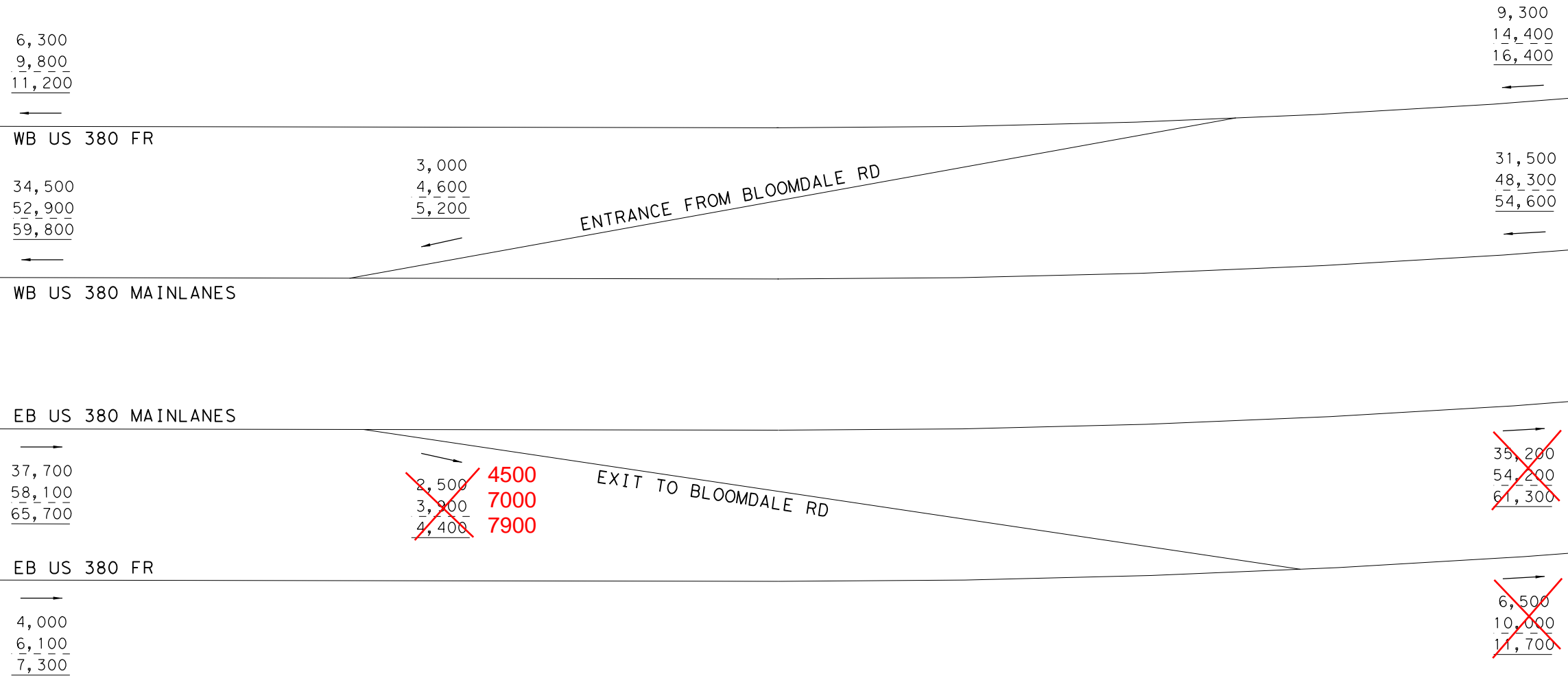


DATE: 7/13/2021
 FILE: US380_BROWN_TRF_10.dgn



SEE SHEET 10 OF 62

SEE SHEET 12 OF 62



LEGEND	
XXXX-	2030 AVERAGE DAILY TRAFFIC VOLUMES
-XXXX-	2050 AVERAGE DAILY TRAFFIC VOLUMES
XXXX-	2060 AVERAGE DAILY TRAFFIC VOLUMES

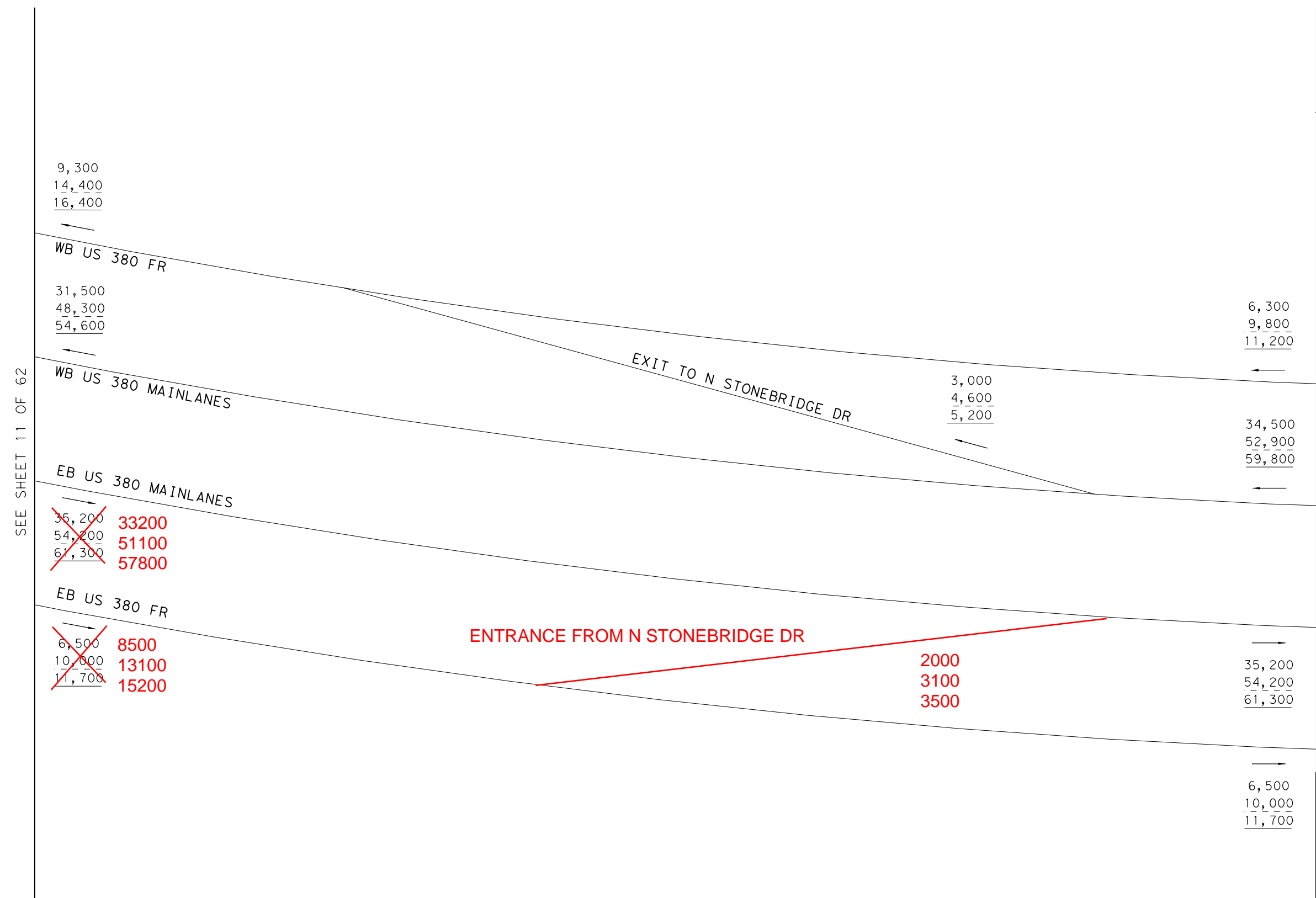
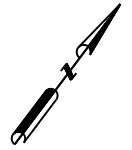
33200
51100
57800
8500
13100
15200

NOT TO SCALE

NOT INTENDED FOR CONSTRUCTION,
 BIDDING OR PERMIT PURPOSES
 DHRUVA LAHON, P.E.
 SERIAL NUMBER 102185

US 380 BROWN ALT AND
 RAMP
 AVERAGE DAILY TRAFFIC
 BROWN ALT BUILD VOLUMES





SEE SHEET 11 OF 62

SEE SHEET 13 OF 62

NOT TO SCALE

NOT INTENDED FOR CONSTRUCTION,
 BIDDING OR PERMIT PURPOSES
 DHRUVA LAHON, P.E.
 SERIAL NUMBER 102185

US 380 BROWN ALT AND
 RAMPS
 AVERAGE DAILY TRAFFIC
 BROWN ALT BUILD VOLUMES

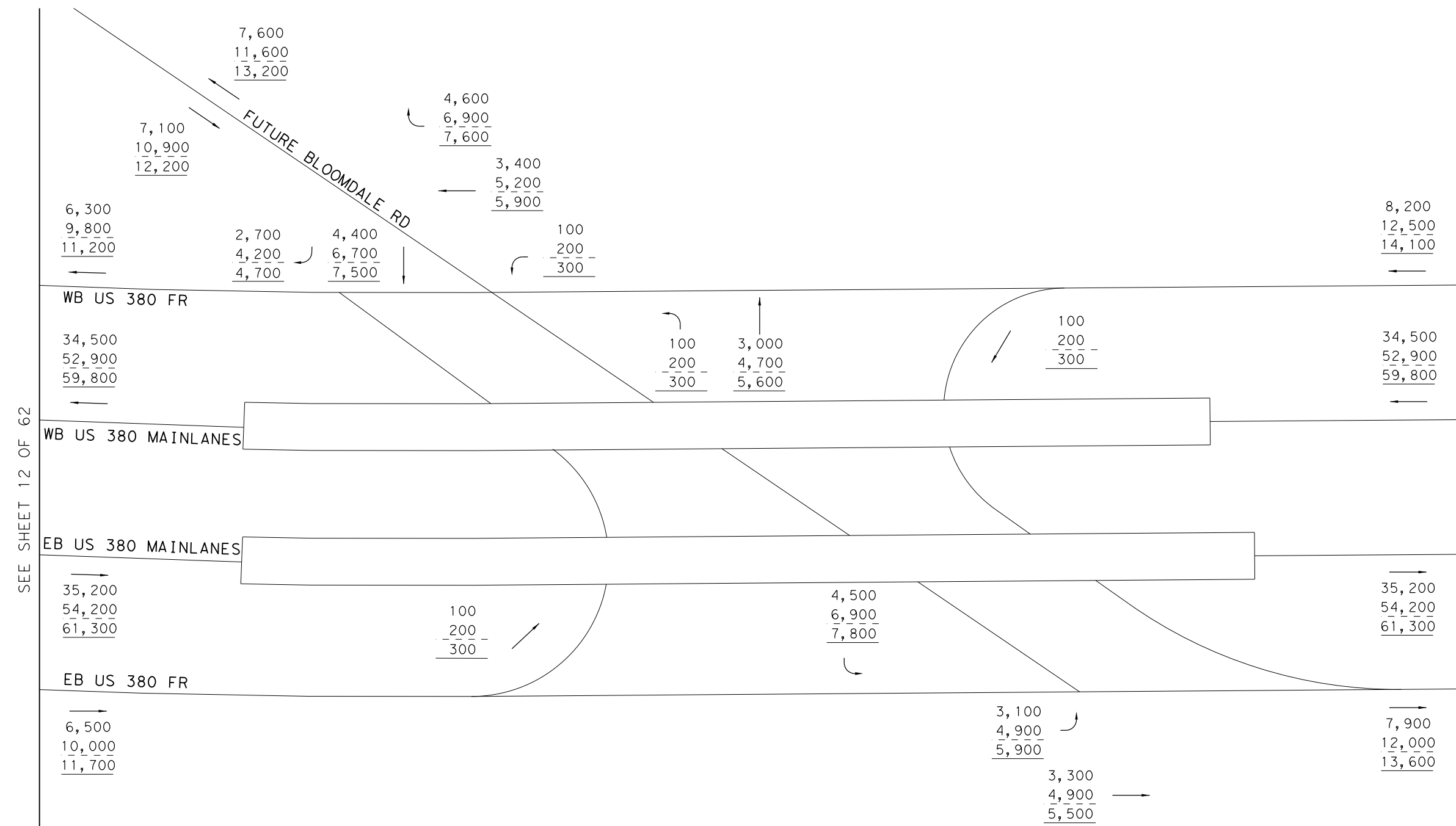
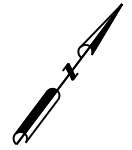


0135-02-065,
 ETC. SHEET 12 OF 62

LEGEND

- XXXX- 2030 AVERAGE DAILY TRAFFIC VOLUMES
- XXXX- 2050 AVERAGE DAILY TRAFFIC VOLUMES
- XXXX- 2060 AVERAGE DAILY TRAFFIC VOLUMES

DATE: 7/13/2021
FILE: US380_BROWN_TRF_12.dgn



SEE SHEET 12 OF 62

SEE SHEET 14 OF 62

NOT TO SCALE

NOT INTENDED FOR CONSTRUCTION,
 BIDDING OR PERMIT PURPOSES
 DHRUVA LAHON, P.E.
 SERIAL NUMBER 102185

US 380 BROWN ALT AND
 W BLOOMDALE RD
 AVERAGE DAILY TRAFFIC
 BROWN ALT BUILD VOLUMES



0135-02-065, ETC. SHEET 13 OF 62

LEGEND

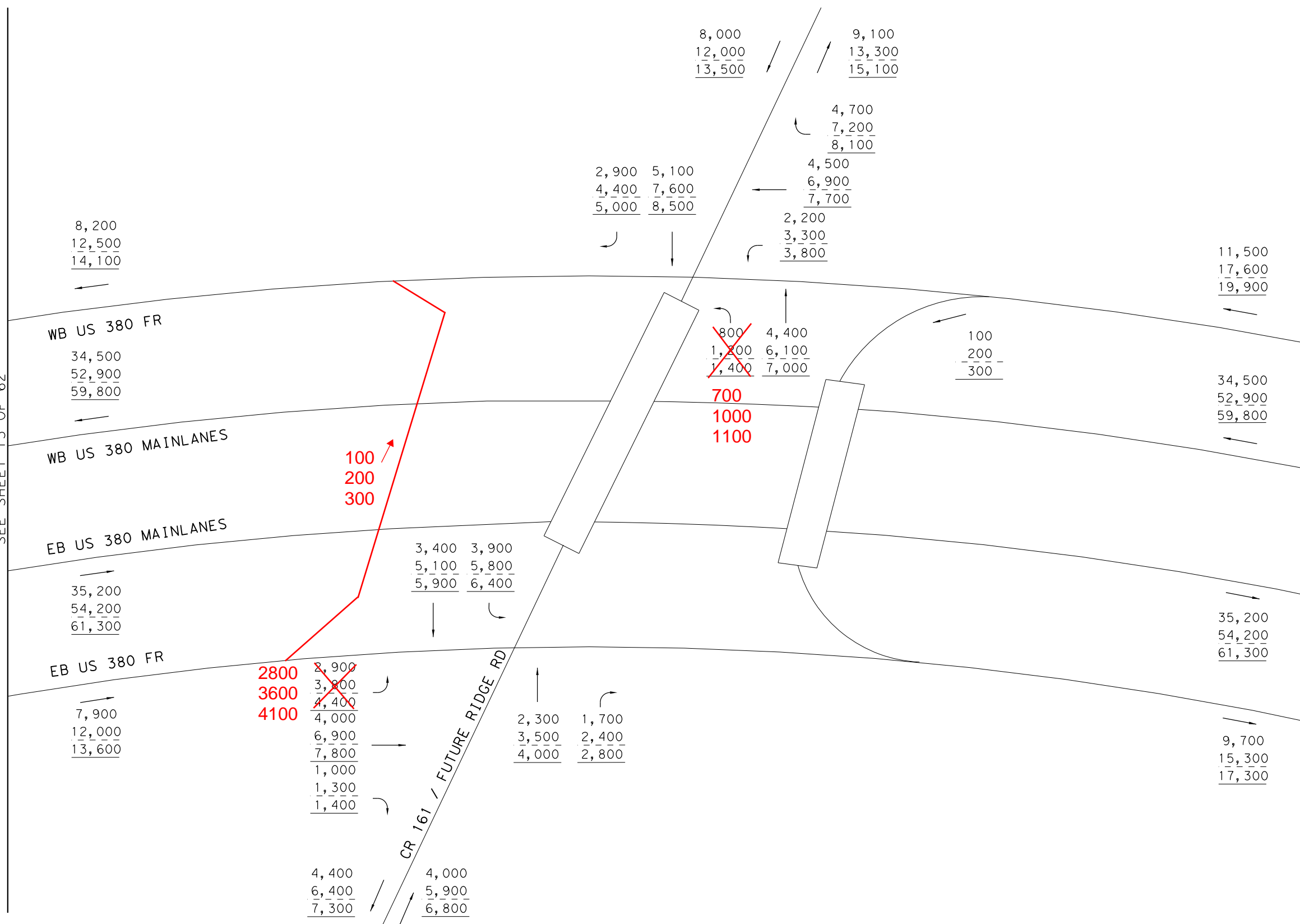
- XXXX- 2030 AVERAGE DAILY TRAFFIC VOLUMES
- XXXX- 2050 AVERAGE DAILY TRAFFIC VOLUMES
- XXXX- 2060 AVERAGE DAILY TRAFFIC VOLUMES

DATE: 7/13/2021
 FILE: US380_BROWN_TRF_13.dgn



SEE SHEET 13 OF 62

SEE SHEET 15 OF 62



NOT TO SCALE

NOT INTENDED FOR CONSTRUCTION,
BIDDING OR PERMIT PURPOSES
DHURVA LAHON, P.E.
SERIAL NUMBER 102185

US 380 BROWN ALT AND
WILMETH RD
AVERAGE DAILY TRAFFIC
BROWN ALT BUILD VOLUMES

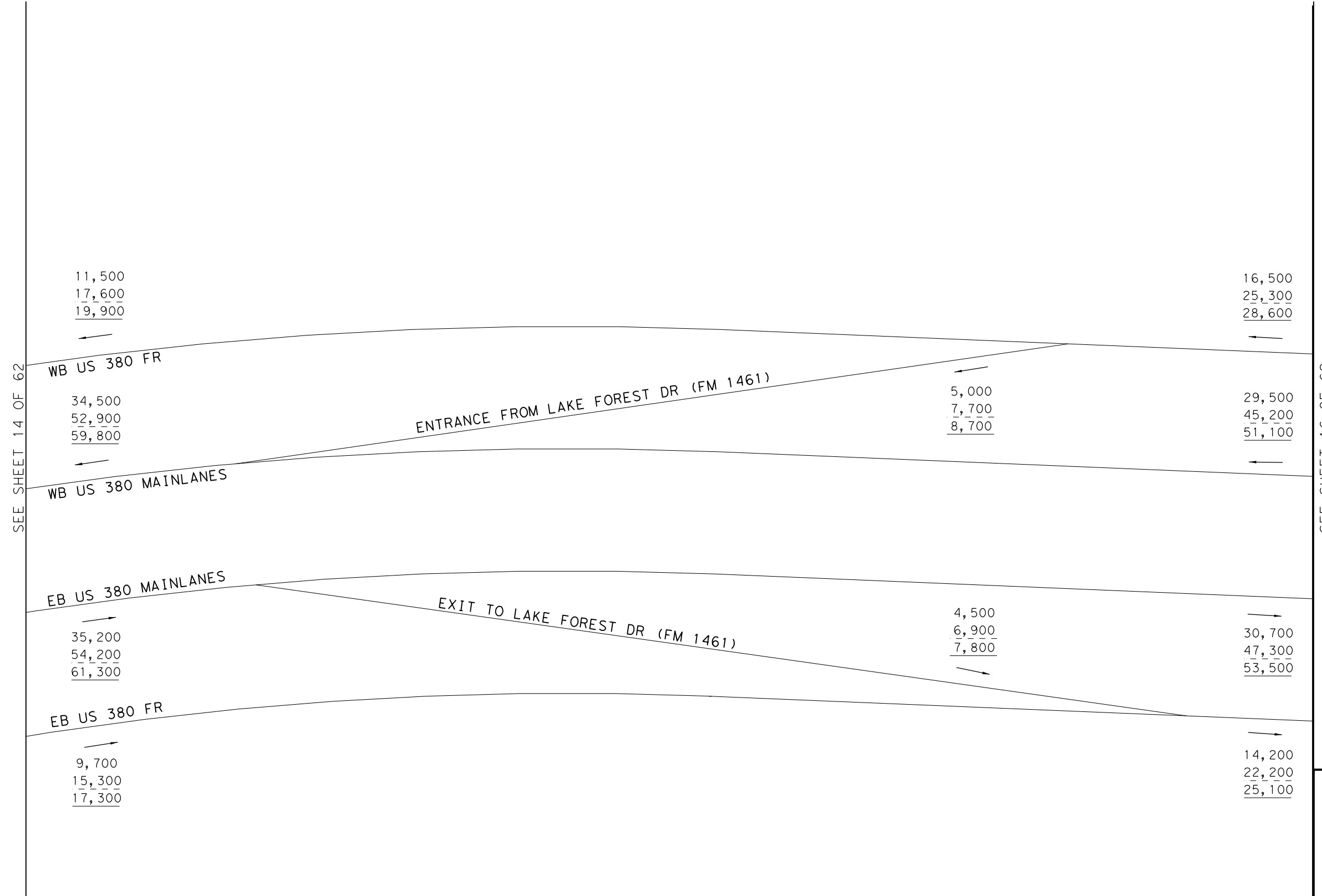


0135-02-065,
ETC. SHEET 14 OF 62

LEGEND

- XXXX- 2030 AVERAGE DAILY TRAFFIC VOLUMES
- XXXX- 2050 AVERAGE DAILY TRAFFIC VOLUMES
- XXXX- 2060 AVERAGE DAILY TRAFFIC VOLUMES

DATE: 7/13/2021
FILE: US380_BROWN_TRF_14.dgn



NOT TO SCALE

NOT INTENDED FOR CONSTRUCTION,
 BIDDING OR PERMIT PURPOSES
 DHRUVA LAHON, P.E.
 SERIAL NUMBER 102185

US 380 BROWN ALT AND
 RAMP
 AVERAGE DAILY TRAFFIC
 BROWN ALT BUILD VOLUMES



0135-02-065,
 ETC. SHEET 15 OF 62

LEGEND

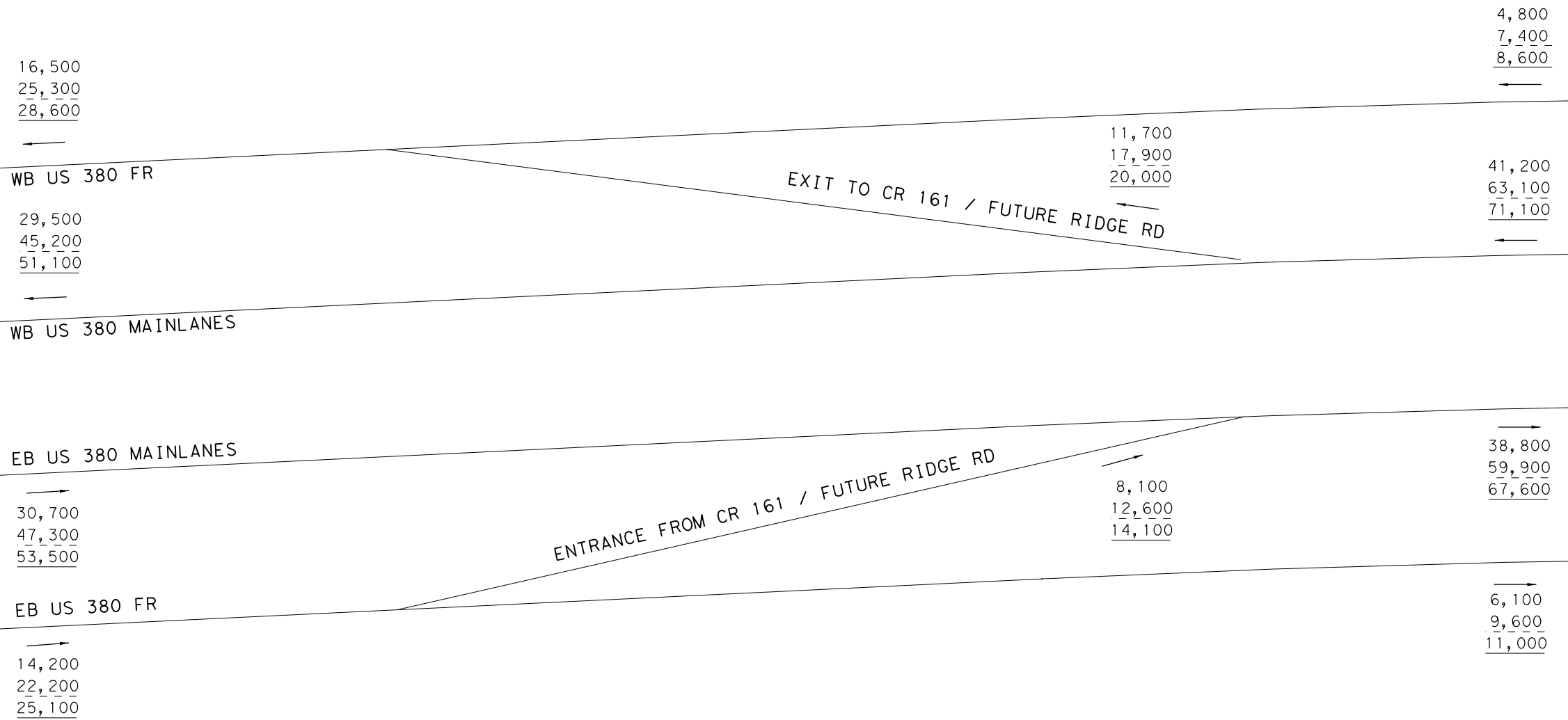
- XXXX- 2030 AVERAGE DAILY TRAFFIC VOLUMES
- XXXX- 2050 AVERAGE DAILY TRAFFIC VOLUMES
- XXXX- 2060 AVERAGE DAILY TRAFFIC VOLUMES

DATE: 7/13/2021
 FILE: US380_BROWN_TRF_15.dgn



SEE SHEET 15 OF 62

SEE SHEET 17 OF 62



NOT TO SCALE

NOT INTENDED FOR CONSTRUCTION,
 BIDDING OR PERMIT PURPOSES
 DHRUVA LAHON, P.E.
 SERIAL NUMBER 102185

US 380 BROWN ALT AND
 RAMPS
 AVERAGE DAILY TRAFFIC
 BROWN ALT BUILD VOLUMES

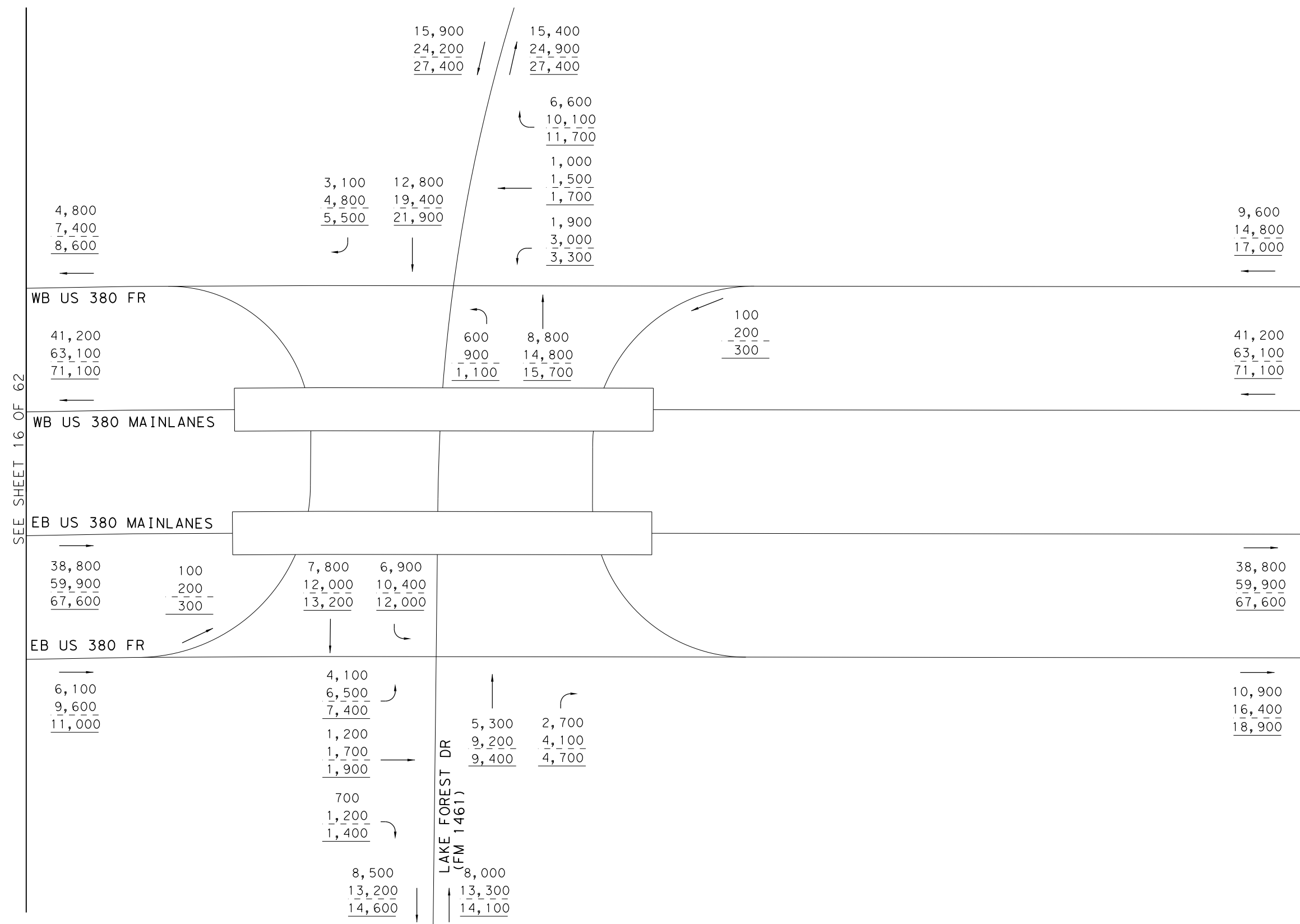


0135-02-065,
 ETC. SHEET 16 OF 62

LEGEND

- XXXX- 2030 AVERAGE DAILY TRAFFIC VOLUMES
- XXXX- 2050 AVERAGE DAILY TRAFFIC VOLUMES
- XXXX- 2060 AVERAGE DAILY TRAFFIC VOLUMES

DATE: 7/13/2021
 FILE: US380_BROWN_TRF_16.dgn



SEE SHEET 16 OF 62

SEE SHEET 18 OF 62

NOT TO SCALE

NOT INTENDED FOR CONSTRUCTION,
 BIDDING OR PERMIT PURPOSES
 DHRUVA LAHON, P.E.
 SERIAL NUMBER 102185

US 380 BROWN ALT AND
 LAKE FOREST DR
 AVERAGE DAILY TRAFFIC
 BROWN ALT BUILD VOLUMES



0135-02-065,
 ETC. SHEET 17 OF 62

LEGEND

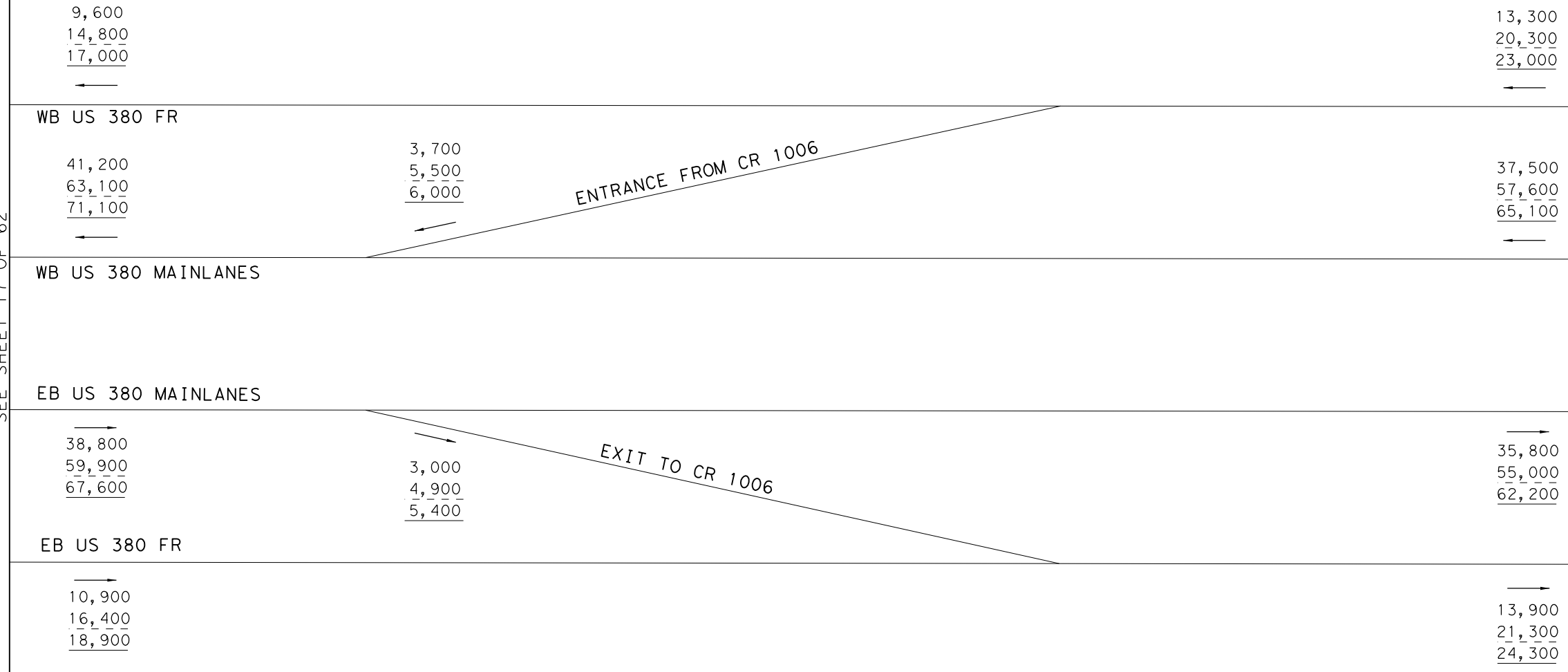
- XXXX- 2030 AVERAGE DAILY TRAFFIC VOLUMES
- XXXX- 2050 AVERAGE DAILY TRAFFIC VOLUMES
- XXXX- 2060 AVERAGE DAILY TRAFFIC VOLUMES

DATE: 7/13/2021
 FILE: US380_BROWN_TRF_17.dgn



SEE SHEET 17 OF 62

SEE SHEET 19 OF 62



NOT TO SCALE

NOT INTENDED FOR CONSTRUCTION,
 BIDDING OR PERMIT PURPOSES
 DHRUVA LAHON, P.E.
 SERIAL NUMBER 102185

US 380 BROWN ALT AND
 RAMPS
 AVERAGE DAILY TRAFFIC
 BROWN ALT BUILD VOLUMES



0135-02-065,
 ETC. SHEET 18 OF 62

LEGEND

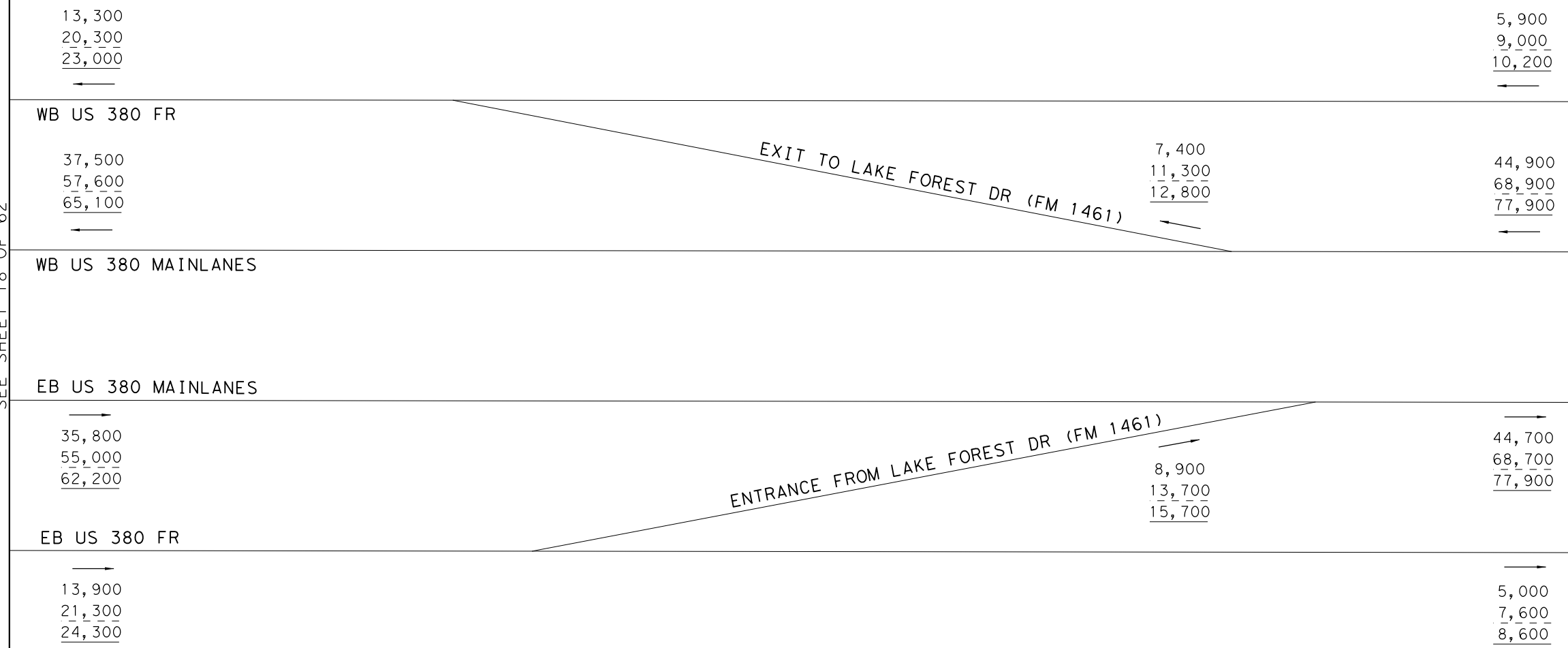
- XXXX- 2030 AVERAGE DAILY TRAFFIC VOLUMES
- XXXX- 2050 AVERAGE DAILY TRAFFIC VOLUMES
- XXXX- 2060 AVERAGE DAILY TRAFFIC VOLUMES

DATE: 7/13/2021
 FILE: US380_BROWN_TRF_18.dgn



SEE SHEET 18 OF 62

SEE SHEET 20 OF 62



NOT TO SCALE

NOT INTENDED FOR CONSTRUCTION,
 BIDDING OR PERMIT PURPOSES
 DHRUVA LAHON, P.E.
 SERIAL NUMBER 102185

US 380 BROWN ALT AND
 RAMPS
 AVERAGE DAILY TRAFFIC
 BROWN ALT BUILD VOLUMES



0135-02-065,
 ETC. SHEET 19 OF 62

LEGEND

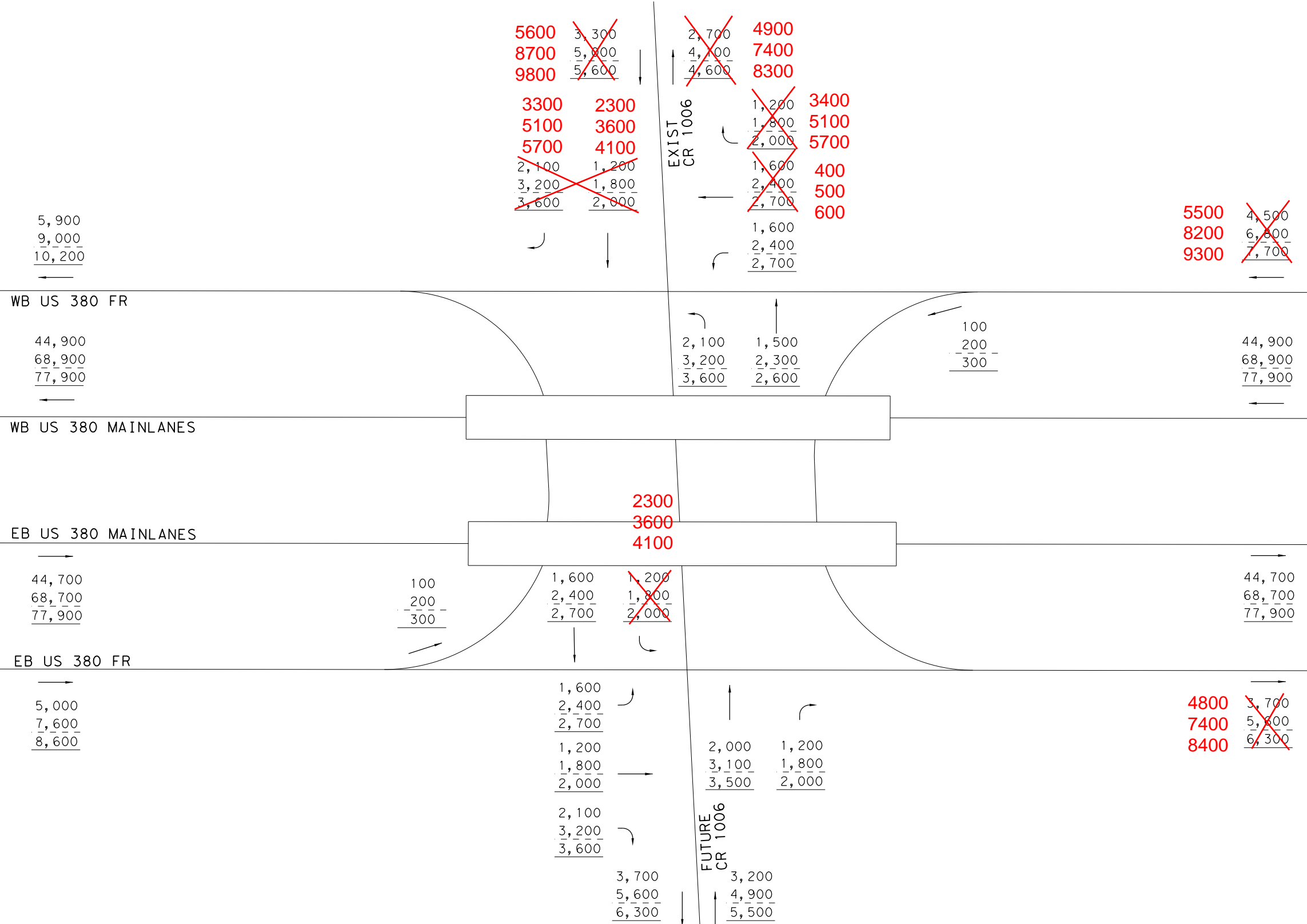
- XXXX- 2030 AVERAGE DAILY TRAFFIC VOLUMES
- XXXX- 2050 AVERAGE DAILY TRAFFIC VOLUMES
- XXXX- 2060 AVERAGE DAILY TRAFFIC VOLUMES

DATE: 7/13/2021
 FILE: US380_BROWN_TRF_19.dgn



SEE SHEET 19 OF 62

SEE SHEET 21 OF 62



LEGEND

- XXXX- 2030 AVERAGE DAILY TRAFFIC VOLUMES
- XXXX- 2050 AVERAGE DAILY TRAFFIC VOLUMES
- XXXX- 2060 AVERAGE DAILY TRAFFIC VOLUMES

NOT TO SCALE

NOT INTENDED FOR CONSTRUCTION,
 BIDDING OR PERMIT PURPOSES
 DHRUVA LAHON, P.E.
 SERIAL NUMBER 102185

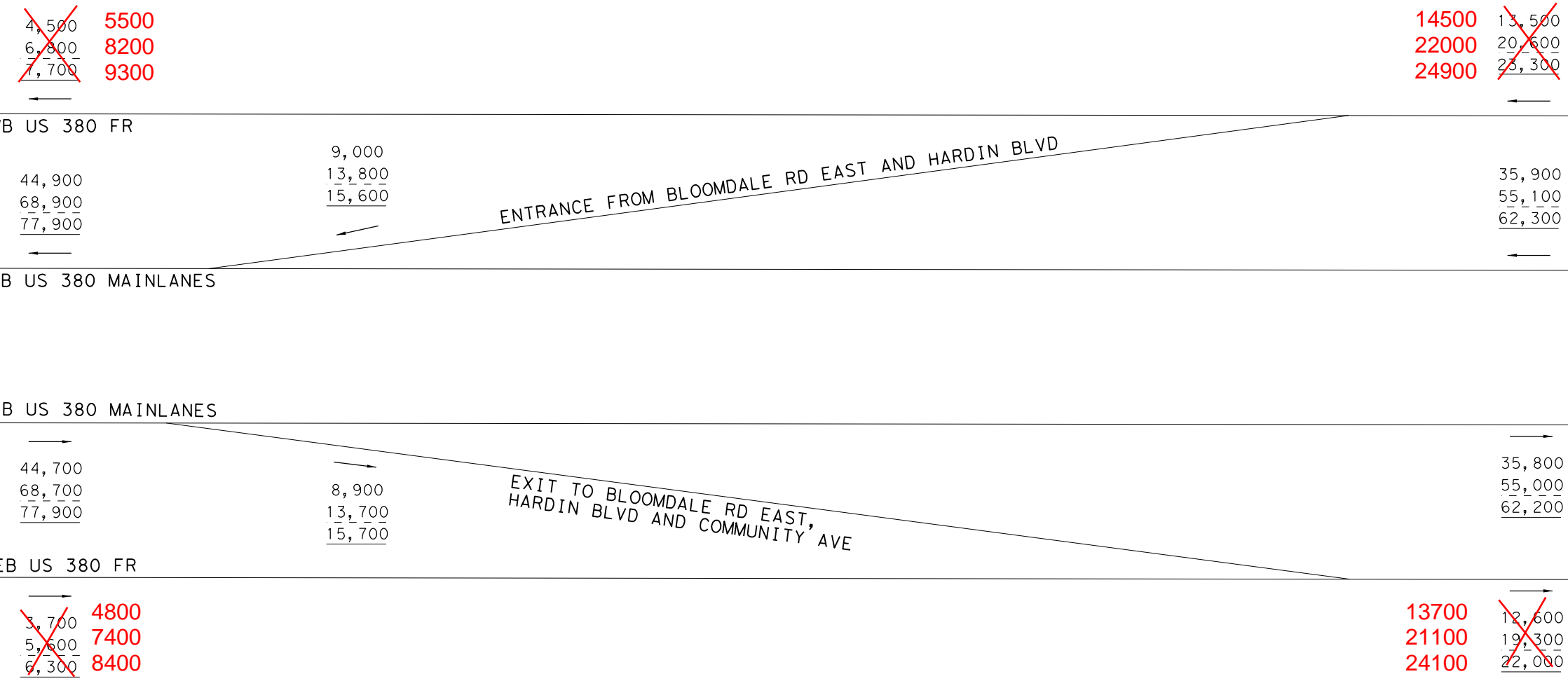
US 380 BROWN ALT AND
 CR 1006
 AVERAGE DAILY TRAFFIC
 BROWN ALT BUILD VOLUMES





SEE SHEET 20 OF 62

SEE SHEET 22 OF 62



ENTRANCE FROM BLOOMDALE RD EAST AND HARDIN BLVD

EXIT TO BLOOMDALE RD EAST, HARDIN BLVD AND COMMUNITY AVE

NOT TO SCALE

NOT INTENDED FOR CONSTRUCTION,
 BIDDING OR PERMIT PURPOSES
 DHRUVA LAHON, P.E.
 SERIAL NUMBER 102185

US 380 BROWN ALT AND RAMP
 AVERAGE DAILY TRAFFIC BROWN ALT BUILD VOLUMES



LEGEND

- XXXX- 2030 AVERAGE DAILY TRAFFIC VOLUMES
- XXXX- 2050 AVERAGE DAILY TRAFFIC VOLUMES
- XXXX- 2060 AVERAGE DAILY TRAFFIC VOLUMES



13,500	14500
20,600	22000
23,300	24900

12200	11,200
18600	17,800
21200	19,600

WB US 380 FR

35,900
<u>55,100</u>
62,300

2,300
<u>3,400</u>
3,700

38,200
<u>58,500</u>
66,000

WB US 380 MAINLANES

EXIT TO CR 1006

SEE SHEET 21 OF 62

SEE SHEET 23 OF 62

EB US 380 MAINLANES

35,800
<u>55,000</u>
62,200

2,000
<u>2,800</u>
3,100

37,800
<u>57,800</u>
65,300

EB US 380 FR

ENTRANCE FROM CR 1006

12,600	13700
19,300	21100
22,000	24100

11700	10,600
18300	16,500
21000	18,900

NOT TO SCALE

NOT INTENDED FOR CONSTRUCTION,
BIDDING OR PERMIT PURPOSES
DHURVA LAHON, P.E.
SERIAL NUMBER 102185

US 380 BROWN ALT AND
RAMPS
AVERAGE DAILY TRAFFIC
BROWN ALT BUILD VOLUMES

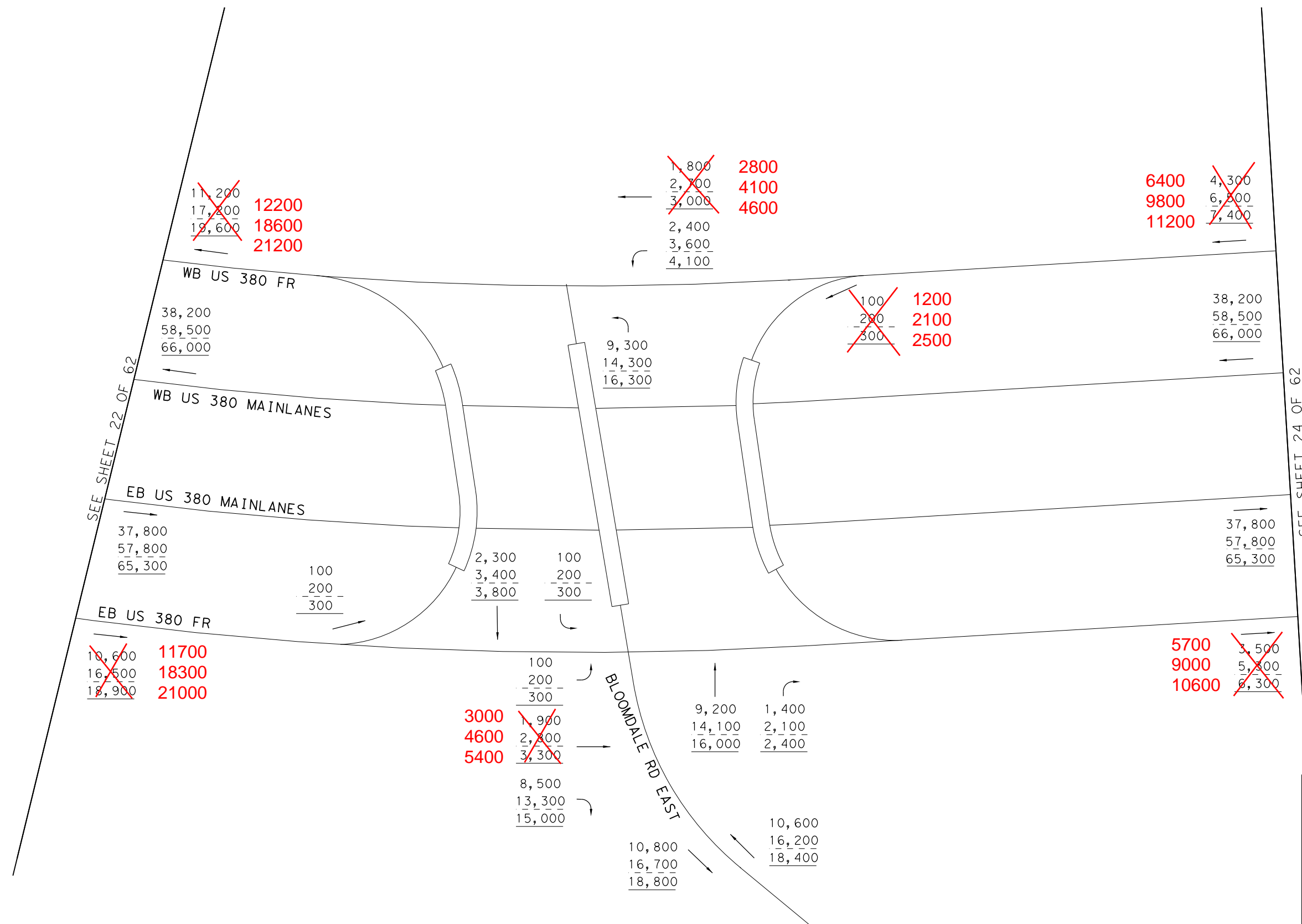
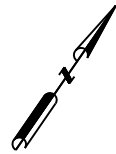
Kimley»Horn
F-928

0135-02-065,
ETC. SHEET 22 OF 62

LEGEND

XXXX-	2030	AVERAGE	DAILY	TRAFFIC	VOLUMES
-XXXX-	2050	AVERAGE	DAILY	TRAFFIC	VOLUMES
<u>XXXX-</u>	2060	AVERAGE	DAILY	TRAFFIC	VOLUMES

DATE: 7/13/2021
FILE: US380_BROWN_TRF_22.dgn



SEE SHEET 22 OF 62

SEE SHEET 24 OF 62

NOT TO SCALE

NOT INTENDED FOR CONSTRUCTION,
 BIDDING OR PERMIT PURPOSES
 DHRUVA LAHON, P.E.
 SERIAL NUMBER 102185

US 380 BROWN ALT AND
 E BLOOMDALE RD
 AVERAGE DAILY TRAFFIC
 BROWN ALT BUILD VOLUMES

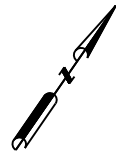
Kimley»Horn
F-928

0135-02-065,
 ETC. SHEET 23 OF 62

LEGEND

- XXXX- 2030 AVERAGE DAILY TRAFFIC VOLUMES
- XXXX- 2050 AVERAGE DAILY TRAFFIC VOLUMES
- XXXX- 2060 AVERAGE DAILY TRAFFIC VOLUMES

DATE: 7/13/2021
 FILE: US380_BROWN_TRF_23.dgn



RD 201

2400
3700
4200
↓

2200
3300
3800
↑

2400
3700
4200
↓

2200
3300
3800
4000
6100
7000

~~4,300~~
~~6,500~~
~~7,400~~

~~4,300~~
~~6,500~~
~~7,400~~

6400
9800
11200

WB US 380 FR

38,200
58,500
66,000

38,200
58,500
66,000

WB US 380 MAINLANES

EB US 380 MAINLANES

37,800
57,800
65,300

37,800
57,800
65,300

EB US 380 FR

~~3,500~~
~~5,700~~
~~6,300~~

5700
9000
10600

5700
9000
10600

~~3,500~~
~~5,700~~
~~6,300~~

SEE SHEET 23 OF 62

SEE SHEET 25 OF 62

NOT TO SCALE

NOT INTENDED FOR CONSTRUCTION,
BIDDING OR PERMIT PURPOSES
DHURVA LAHON, P.E.
SERIAL NUMBER 102185

US 380 BROWN ALT

AVERAGE DAILY TRAFFIC
BROWN ALT BUILD VOLUMES

Kimley»Horn

F-928

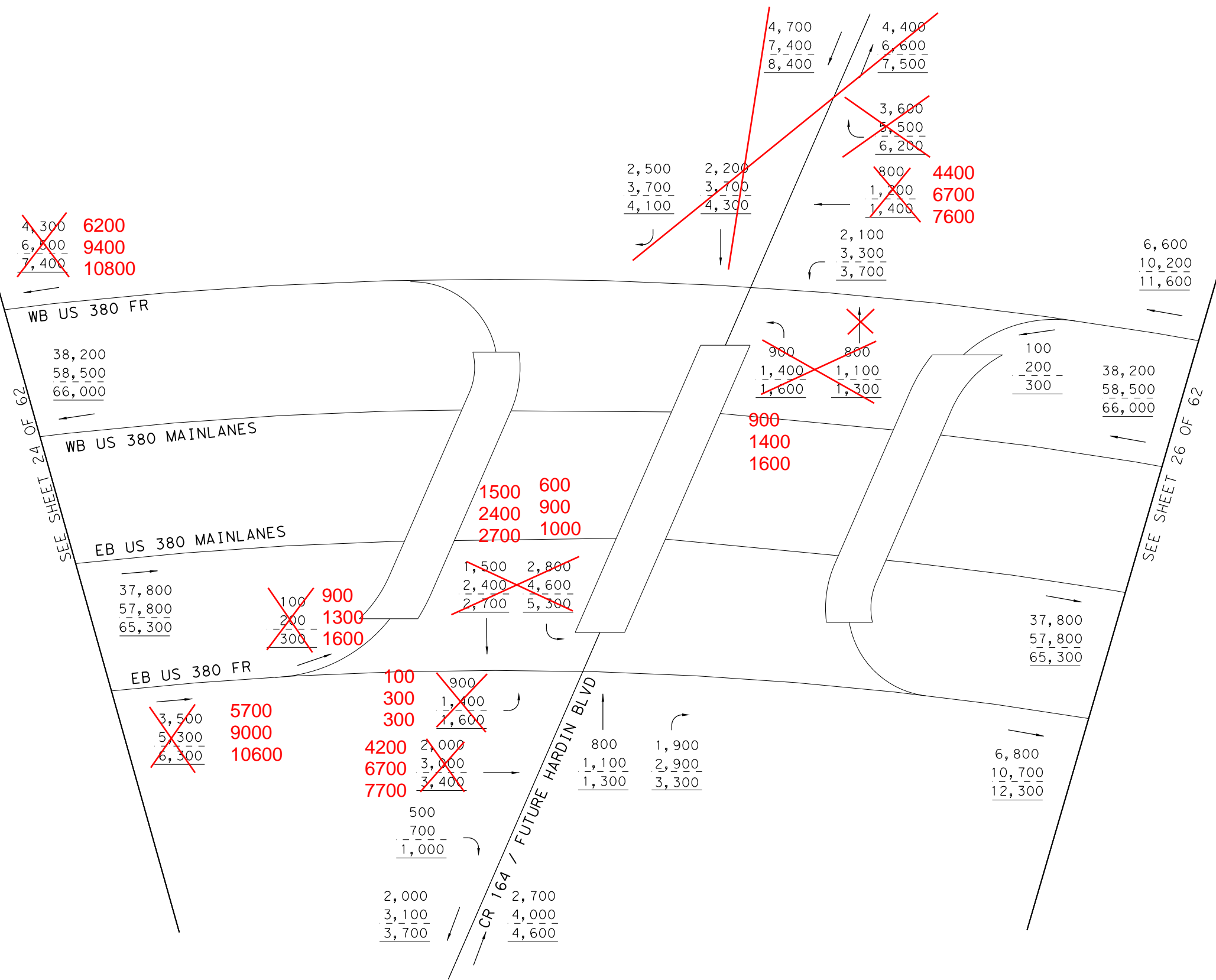
0135-02-065,
ETC.

SHEET 24 OF 62

LEGEND

- XXXX- 2030 AVERAGE DAILY TRAFFIC VOLUMES
- XXXX- 2050 AVERAGE DAILY TRAFFIC VOLUMES
- XXXX- 2060 AVERAGE DAILY TRAFFIC VOLUMES

DATE: 7/13/2021
FILE: US380_BROWN_TRF_24.dgn



SEE SHEET 24 OF 62

SEE SHEET 26 OF 62

WB US 380 FR

WB US 380 MAINLANES

EB US 380 MAINLANES

EB US 380 FR

CR 164 / FUTURE HARDIN BLVD

LEGEND	
XXXX-	2030 AVERAGE DAILY TRAFFIC VOLUMES
-XXXX-	2050 AVERAGE DAILY TRAFFIC VOLUMES
<u>XXXX</u> -	2060 AVERAGE DAILY TRAFFIC VOLUMES

NOT TO SCALE

NOT INTENDED FOR CONSTRUCTION,
 BIDDING OR PERMIT PURPOSES
 DHRUVA LAHON, P.E.
 SERIAL NUMBER 102185

US 380 BROWN ALT AND
 CR 164
 AVERAGE DAILY TRAFFIC
 BROWN ALT BUILD VOLUMES

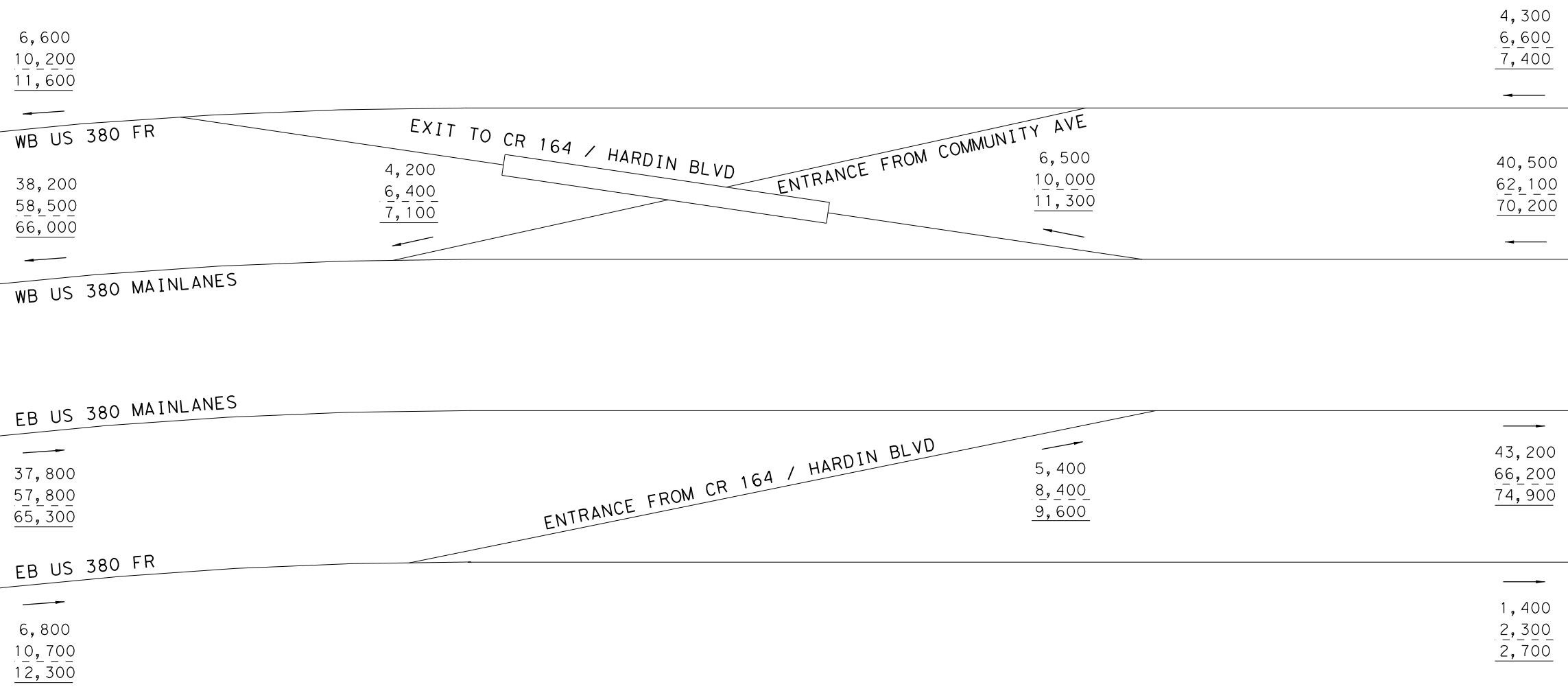


DATE: 7/13/2021
 FILE: US380_BROWN_TRF_25.dgn



SEE SHEET 25 OF 62

SEE SHEET 27 OF 62



NOT TO SCALE

NOT INTENDED FOR CONSTRUCTION,
 BIDDING OR PERMIT PURPOSES
 DHRUVA LAHON, P.E.
 SERIAL NUMBER 102185

US 380 BROWN ALT AND
 RAMPS
 AVERAGE DAILY TRAFFIC
 BROWN ALT BUILD VOLUMES



0135-02-065,
 ETC. SHEET 26 OF 62

LEGEND

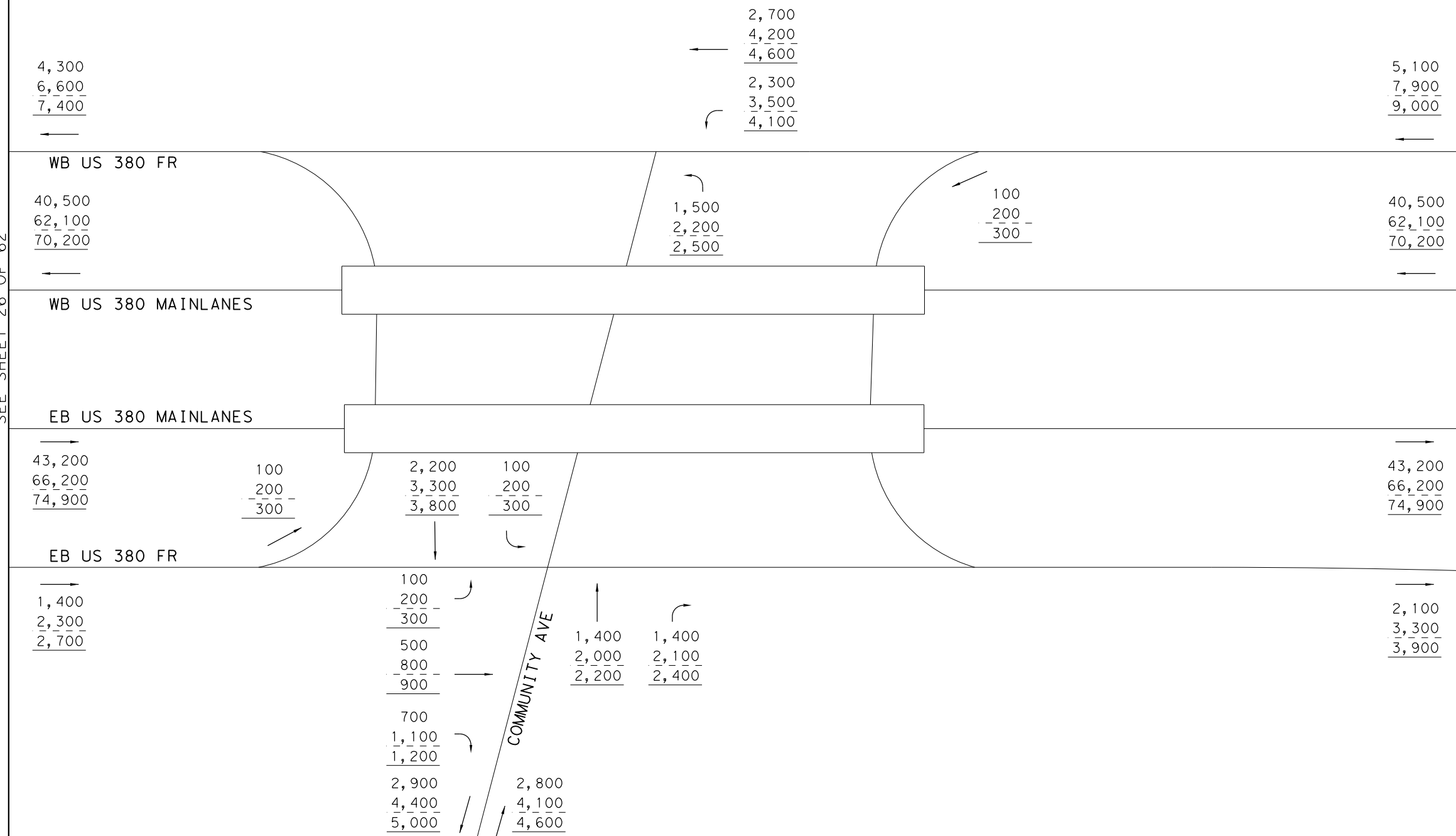
- XXXX- 2030 AVERAGE DAILY TRAFFIC VOLUMES
- XXXX- 2050 AVERAGE DAILY TRAFFIC VOLUMES
- XXXX- 2060 AVERAGE DAILY TRAFFIC VOLUMES

DATE: 7/13/2021
 FILE: US380_BROWN_TRF_26.dgn



SEE SHEET 26 OF 62

SEE SHEET 28 OF 62



NOT TO SCALE

NOT INTENDED FOR CONSTRUCTION,
 BIDDING OR PERMIT PURPOSES
 DHRUVA LAHON, P.E.
 SERIAL NUMBER 102185

US 380 BROWN ALT AND
 COMMUNITY AVE
 AVERAGE DAILY TRAFFIC
 BROWN ALT BUILD VOLUMES



0135-02-065,
 ETC. SHEET 27 OF 62

DATE: 7/13/2021
 FILE: US380_BROWN_TRF_27.dgn



5,100
7,900
9,000

40,500
62,100
70,200

43,200
66,200
74,900

2,100
3,300
3,900

5,100
7,900
9,000

40,500
62,100
70,200

40,000
61,300
69,300

5,300
8,200
9,500

3,200
4,900
5,600

LEGEND

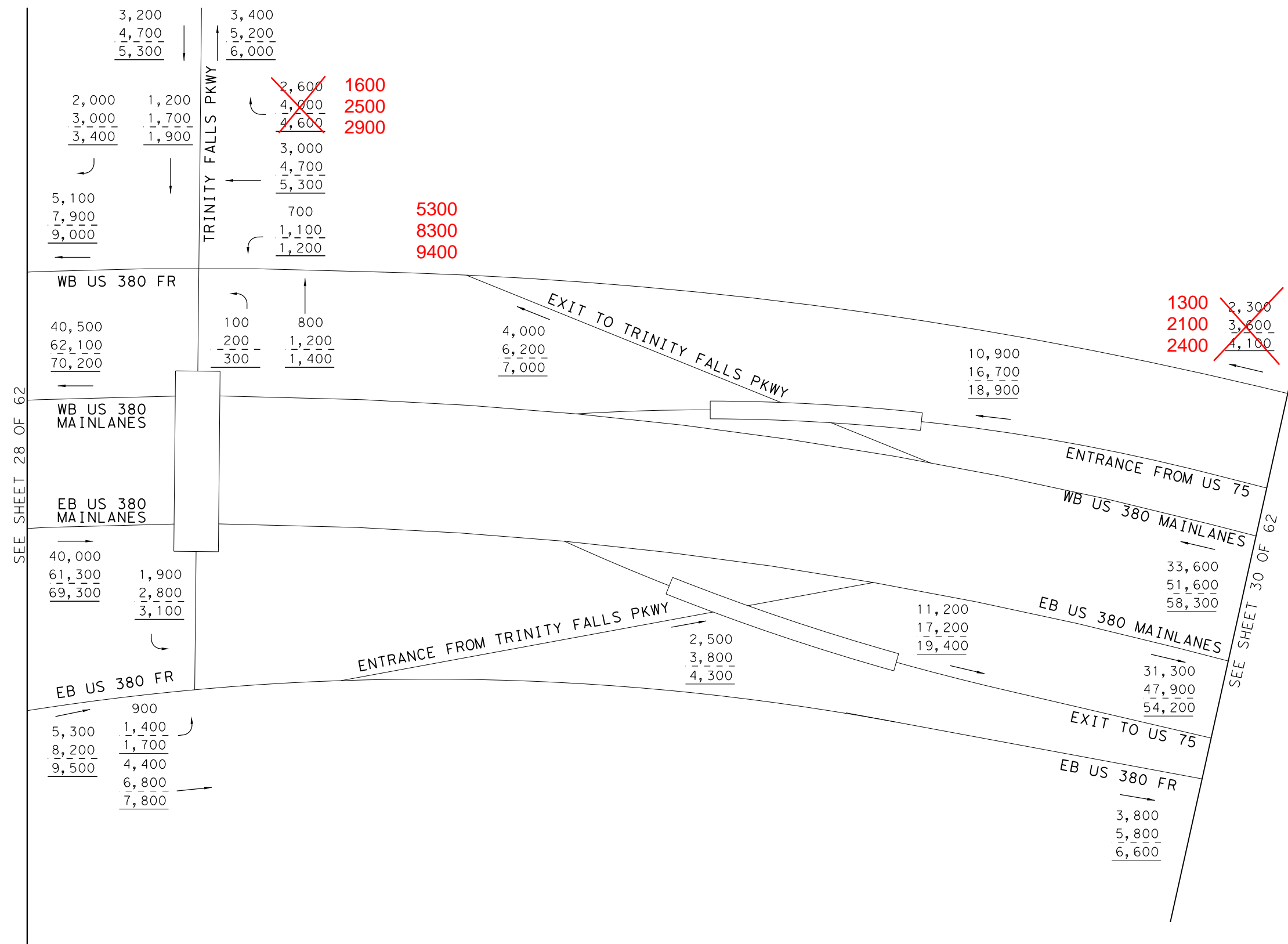
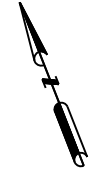
- XXXX- 2030 AVERAGE DAILY TRAFFIC VOLUMES
- XXXX- 2050 AVERAGE DAILY TRAFFIC VOLUMES
- XXXX- 2060 AVERAGE DAILY TRAFFIC VOLUMES

NOT TO SCALE

NOT INTENDED FOR CONSTRUCTION,
BIDDING OR PERMIT PURPOSES
DHURVA LAHON, P.E.
SERIAL NUMBER 102185

US 380 BROWN ALT AND
RAMPS
AVERAGE DAILY TRAFFIC
BROWN ALT BUILD VOLUMES





LEGEND

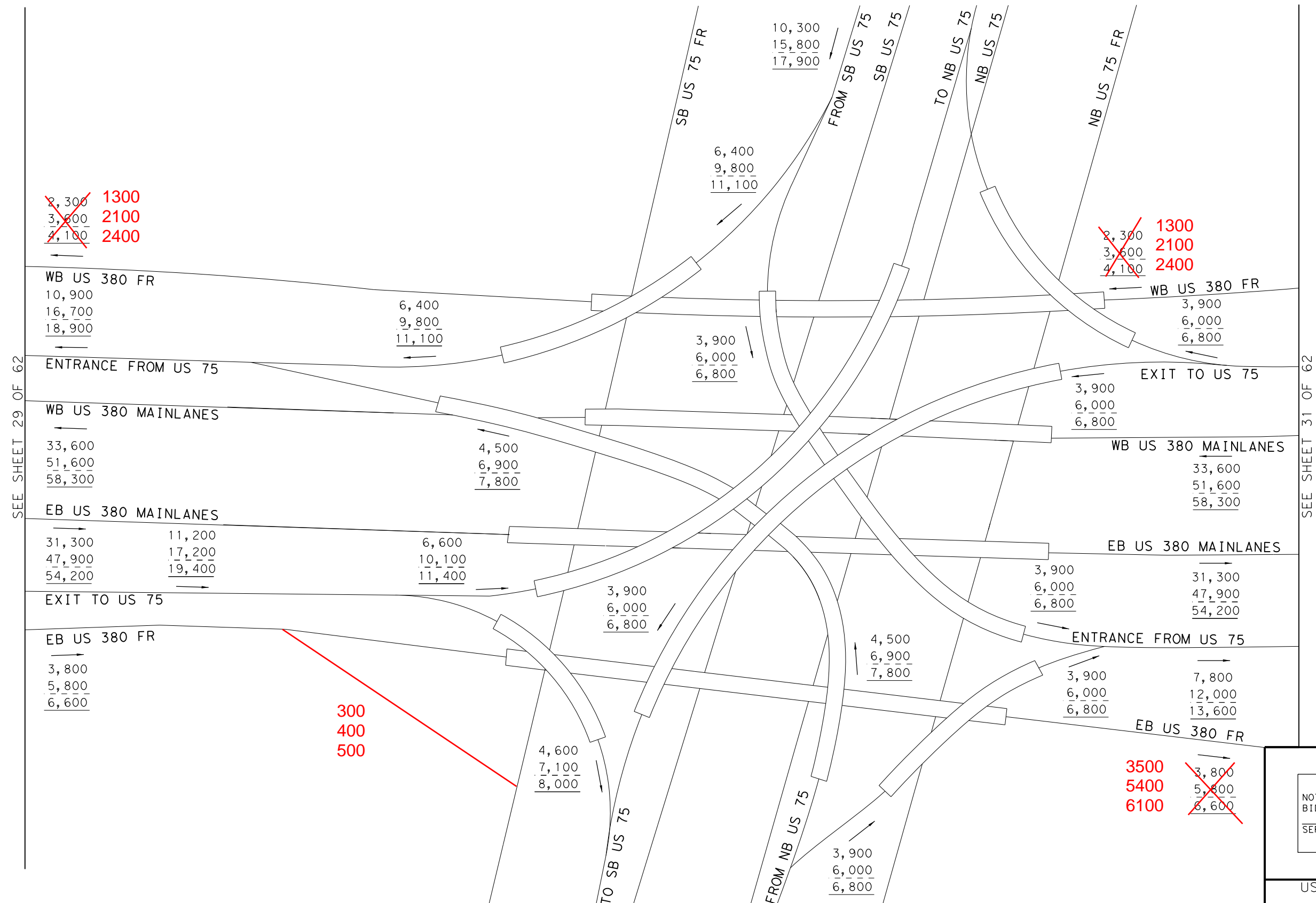
- XXXX- 2030 AVERAGE DAILY TRAFFIC VOLUMES
- XXXX- 2050 AVERAGE DAILY TRAFFIC VOLUMES
- XXXX- 2060 AVERAGE DAILY TRAFFIC VOLUMES

NOT TO SCALE

NOT INTENDED FOR CONSTRUCTION,
BIDDING OR PERMIT PURPOSES
DHURVA LAHON, P.E.
SERIAL NUMBER 102185

US 380 BROWN ALT AND
TRINITY FALLS PKWY
AVERAGE DAILY TRAFFIC
BROWN ALT BUILD VOLUMES





~~2,300~~ 1300
~~3,600~~ 2100
~~4,100~~ 2400

~~2,300~~ 1300
~~3,600~~ 2100
~~4,100~~ 2400

300
400
500

~~3,800~~
~~5,800~~
~~6,600~~
3500
5400
6100

SEE SHEET 29 OF 62

SEE SHEET 31 OF 62

NOT TO SCALE

NOT INTENDED FOR CONSTRUCTION,
BIDDING OR PERMIT PURPOSES
DHURVA LAHON, P.E.
SERIAL NUMBER 102185

US 380 BROWN ALT AND
US 75
AVERAGE DAILY TRAFFIC
BROWN ALT BUILD VOLUMES

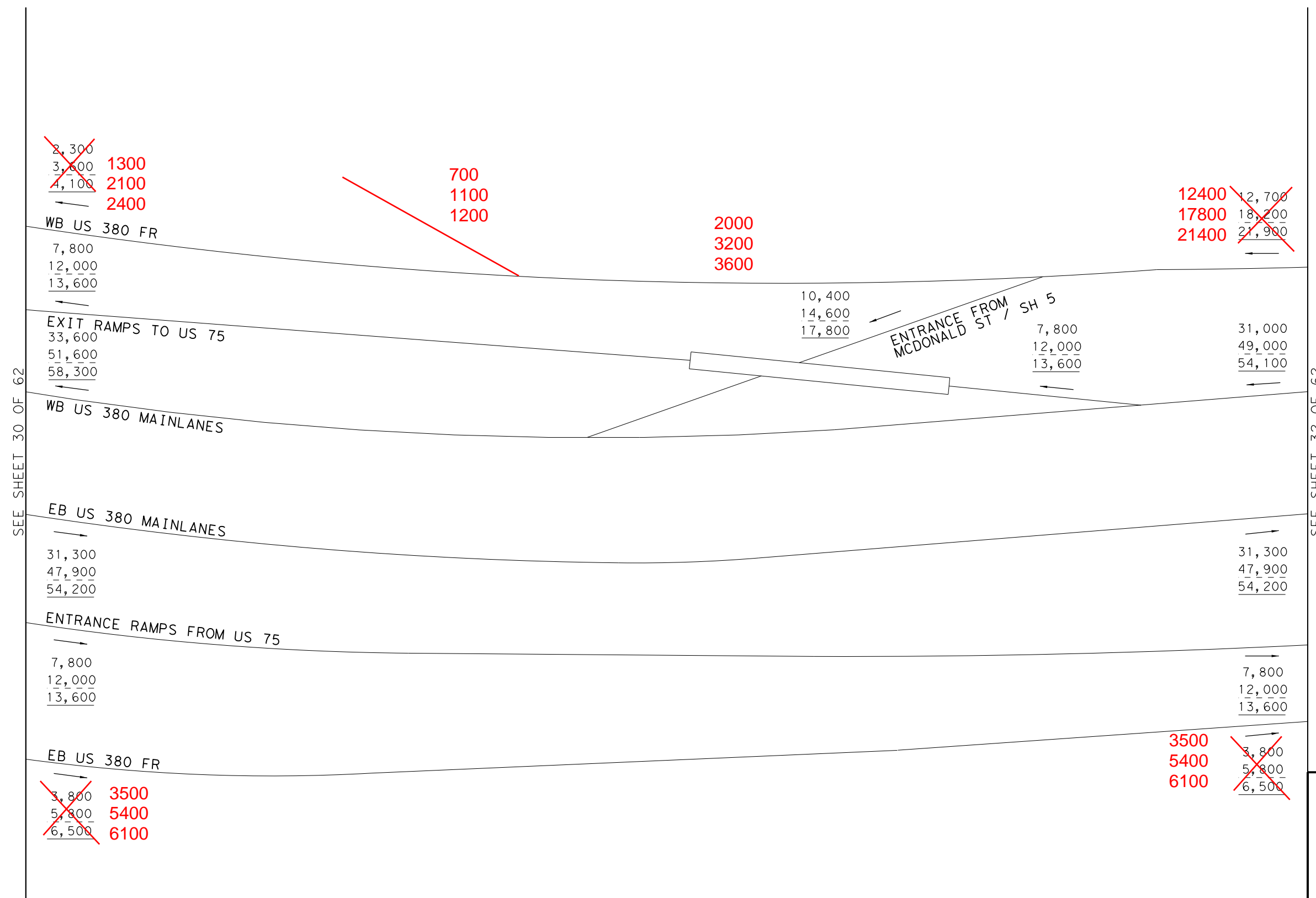
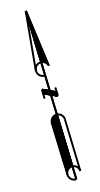
Kimley»Horn
F-928

0135-02-065,
ETC. SHEET 30 OF 62

LEGEND

- XXXX- 2030 AVERAGE DAILY TRAFFIC VOLUMES
- XXXX- 2050 AVERAGE DAILY TRAFFIC VOLUMES
- XXXX- 2060 AVERAGE DAILY TRAFFIC VOLUMES

DATE: 7/13/2021
FILE: US380_BROWN_TRF_30.dgn



~~2,300~~
~~3,600~~
~~4,100~~

1300
 2100
 2400

700
 1100
 1200

2000
 3200
 3600

12400
 17800
 21400

~~12,700~~
~~18,200~~
~~21,900~~

7,800
 12,000
 13,600

10,400
 14,600
 17,800

7,800
 12,000
 13,600

31,000
 49,000
 54,100

33,600
 51,600
 58,300

31,300
 47,900
 54,200

31,300
 47,900
 54,200

7,800
 12,000
 13,600

7,800
 12,000
 13,600

~~3,800~~
~~5,800~~
~~6,500~~

3500
 5400
 6100

3500
 5400
 6100

~~3,800~~
~~5,800~~
~~6,500~~

NOT TO SCALE

NOT INTENDED FOR CONSTRUCTION,
 BIDDING OR PERMIT PURPOSES
 DHRUVA LAHON, P.E.
 SERIAL NUMBER 102185

US 380 BROWN ALT AND
 WESTON RD
 AVERAGE DAILY TRAFFIC
 BROWN ALT BUILD VOLUMES

Kimley»Horn
F-928

0135-02-065,
 ETC.

SHEET 31 OF 62

LEGEND

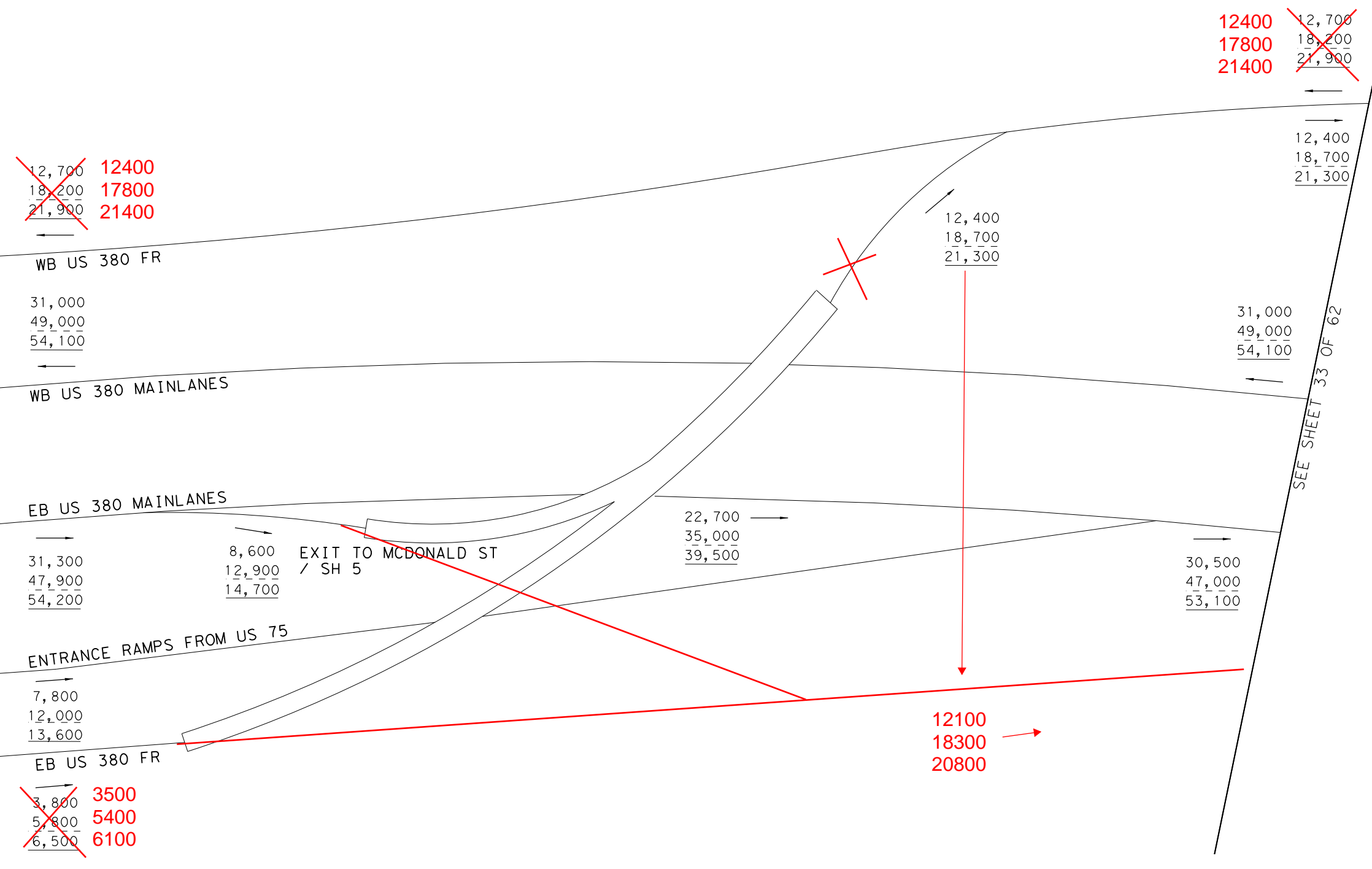
- XXXX- 2030 AVERAGE DAILY TRAFFIC VOLUMES
- XXXX- 2050 AVERAGE DAILY TRAFFIC VOLUMES
- XXXX- 2060 AVERAGE DAILY TRAFFIC VOLUMES

DATE: 7/13/2021
 FILE: US380_BROWN_TRF_31.dgn



SEE SHEET 31 OF 62

SEE SHEET 33 OF 62



LEGEND

- XXXX- 2030 AVERAGE DAILY TRAFFIC VOLUMES
- XXXX- 2050 AVERAGE DAILY TRAFFIC VOLUMES
- XXXX- 2060 AVERAGE DAILY TRAFFIC VOLUMES

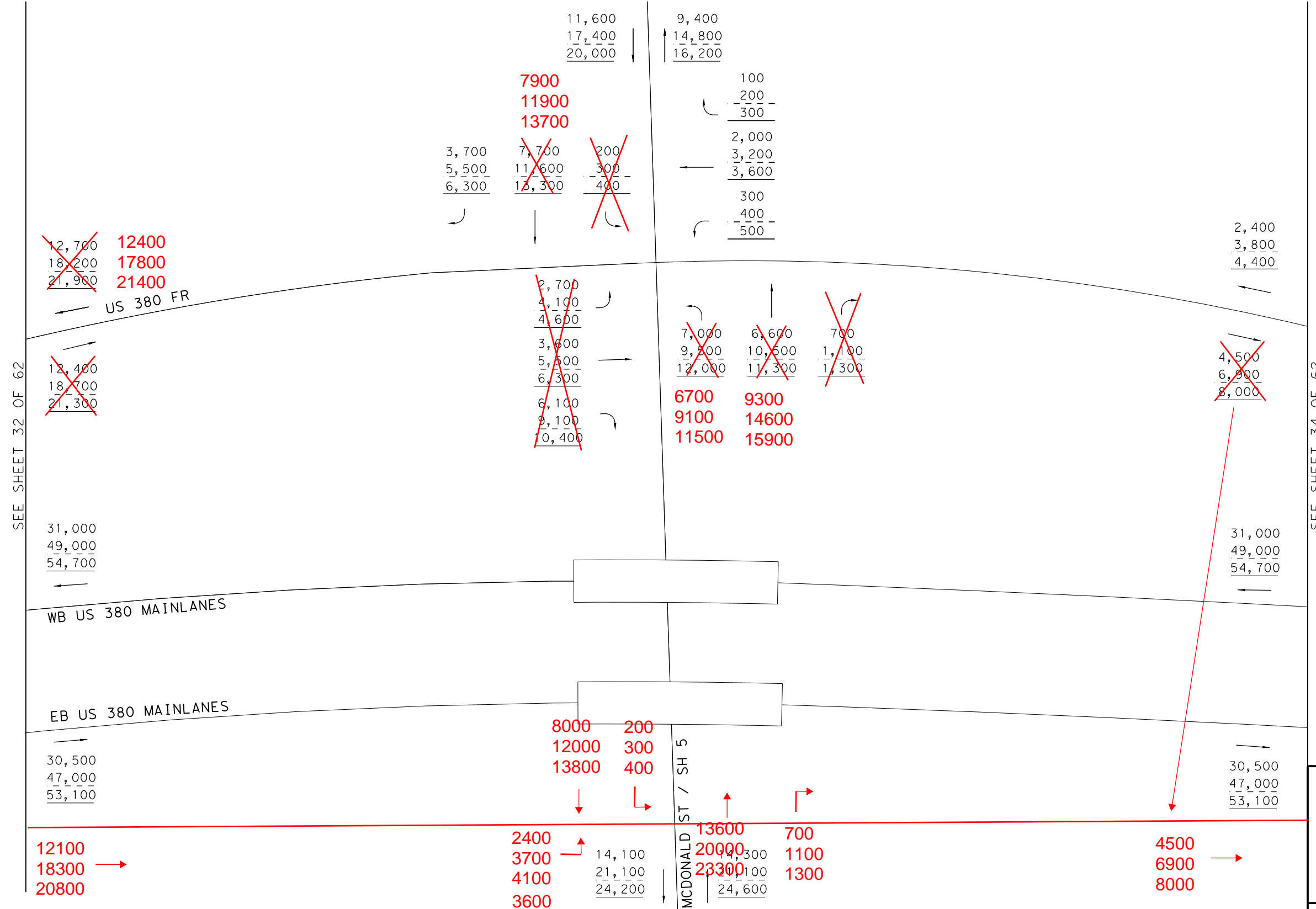
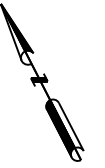
NOT TO SCALE

NOT INTENDED FOR CONSTRUCTION,
 BIDDING OR PERMIT PURPOSES
 DHRUVA LAHON, P.E.
 SERIAL NUMBER 102185

US 380 BROWN ALT AND
 RAMPS
 AVERAGE DAILY TRAFFIC
 BROWN ALT BUILD VOLUMES



DATE: 7/13/2021
 FILE: US380_BROWN_TRF_32.dgn



SEE SHEET 32 OF 62

SEE SHEET 34 OF 62

NOT TO SCALE

NOT INTENDED FOR CONSTRUCTION,
 BIDDING OR PERMIT PURPOSES
 DHRUVA LAHON, P.E.
 SERIAL NUMBER 102185

US 380 BROWN ALT AND
 MCDONALD ST/ SH 5
 AVERAGE DAILY TRAFFIC
 BROWN ALT BUILD VOLUMES

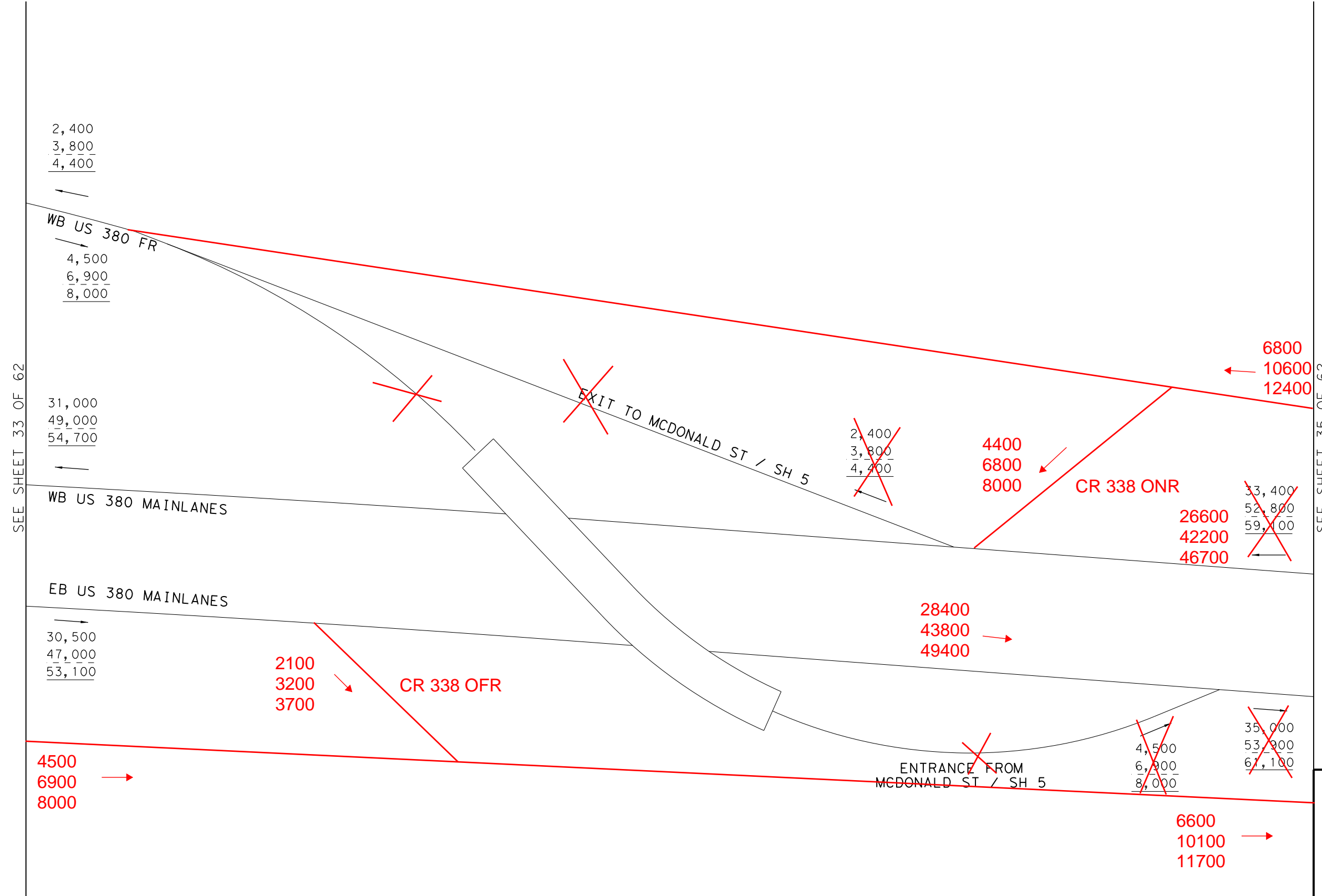
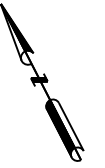


0135-02-065,
 ETC. SHEET 33 OF 62

LEGEND

- XXXX- 2030 AVERAGE DAILY TRAFFIC VOLUMES
- XXXX- 2050 AVERAGE DAILY TRAFFIC VOLUMES
- XXXX- 2060 AVERAGE DAILY TRAFFIC VOLUMES

DATE: 7/13/2021
 FILE: US380_BROWN_TRF_33.dgn



SEE SHEET 33 OF 62

SEE SHEET 35 OF 62

NOT TO SCALE

NOT INTENDED FOR CONSTRUCTION,
 BIDDING OR PERMIT PURPOSES
 DHRUVA LAHON, P.E.
 SERIAL NUMBER 102185

US 380 BROWN ALT AND
 RAMPS
 AVERAGE DAILY TRAFFIC
 BROWN ALT BUILD VOLUMES

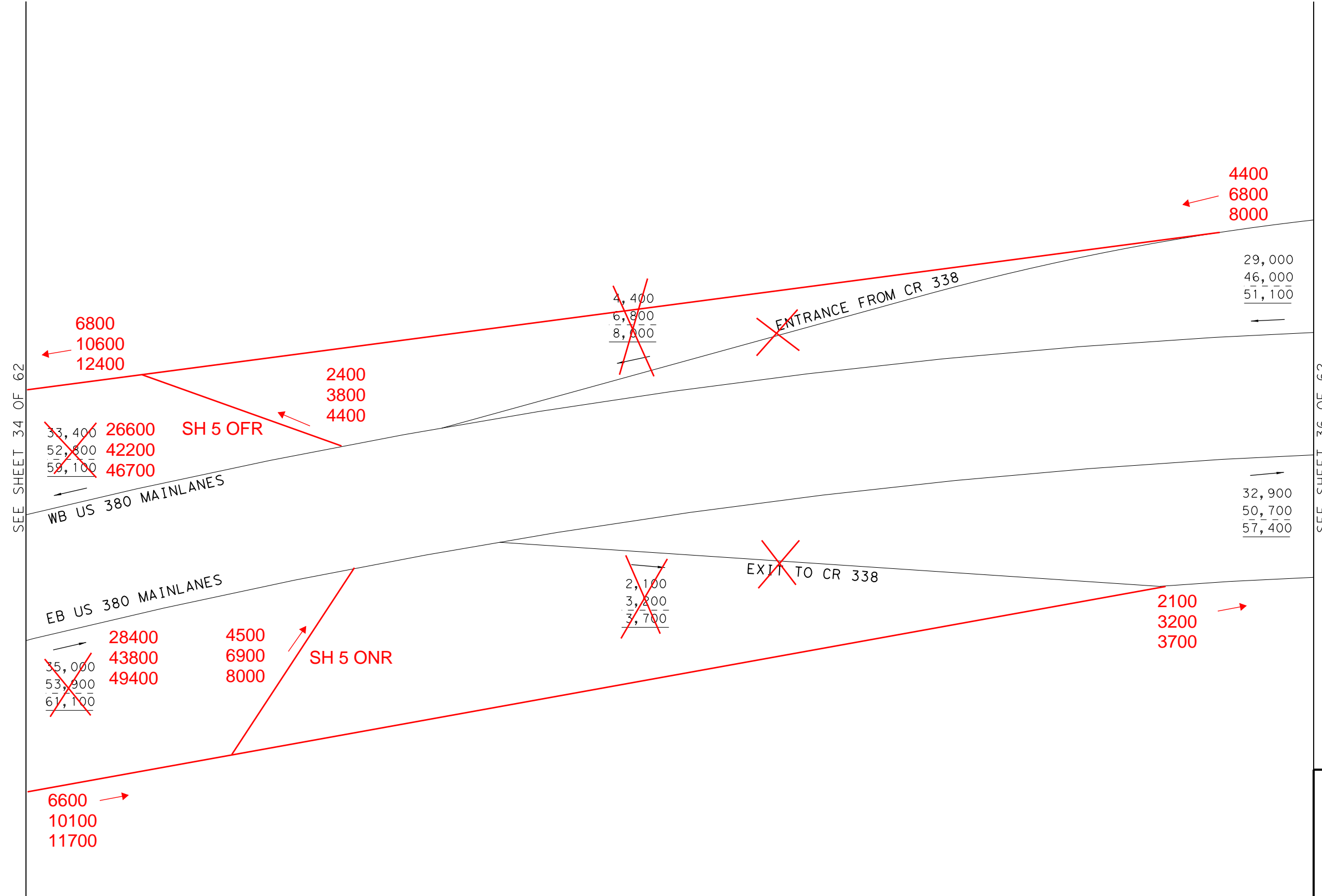
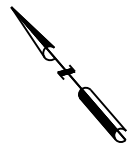


0135-02-065,
 ETC. SHEET 34 OF 62

LEGEND

- XXXX- 2030 AVERAGE DAILY TRAFFIC VOLUMES
- XXXX- 2050 AVERAGE DAILY TRAFFIC VOLUMES
- XXXX- 2060 AVERAGE DAILY TRAFFIC VOLUMES

DATE: 7/13/2021
 FILE: US380_BROWN_TRF_34.dgn



SEE SHEET 34 OF 62

SEE SHEET 36 OF 62

NOT TO SCALE

NOT INTENDED FOR CONSTRUCTION,
 BIDDING OR PERMIT PURPOSES
 DHRUVA LAHON, P.E.
 SERIAL NUMBER 102185

US 380 BROWN ALT AND
 RAMPS
 AVERAGE DAILY TRAFFIC
 BROWN ALT BUILD VOLUMES

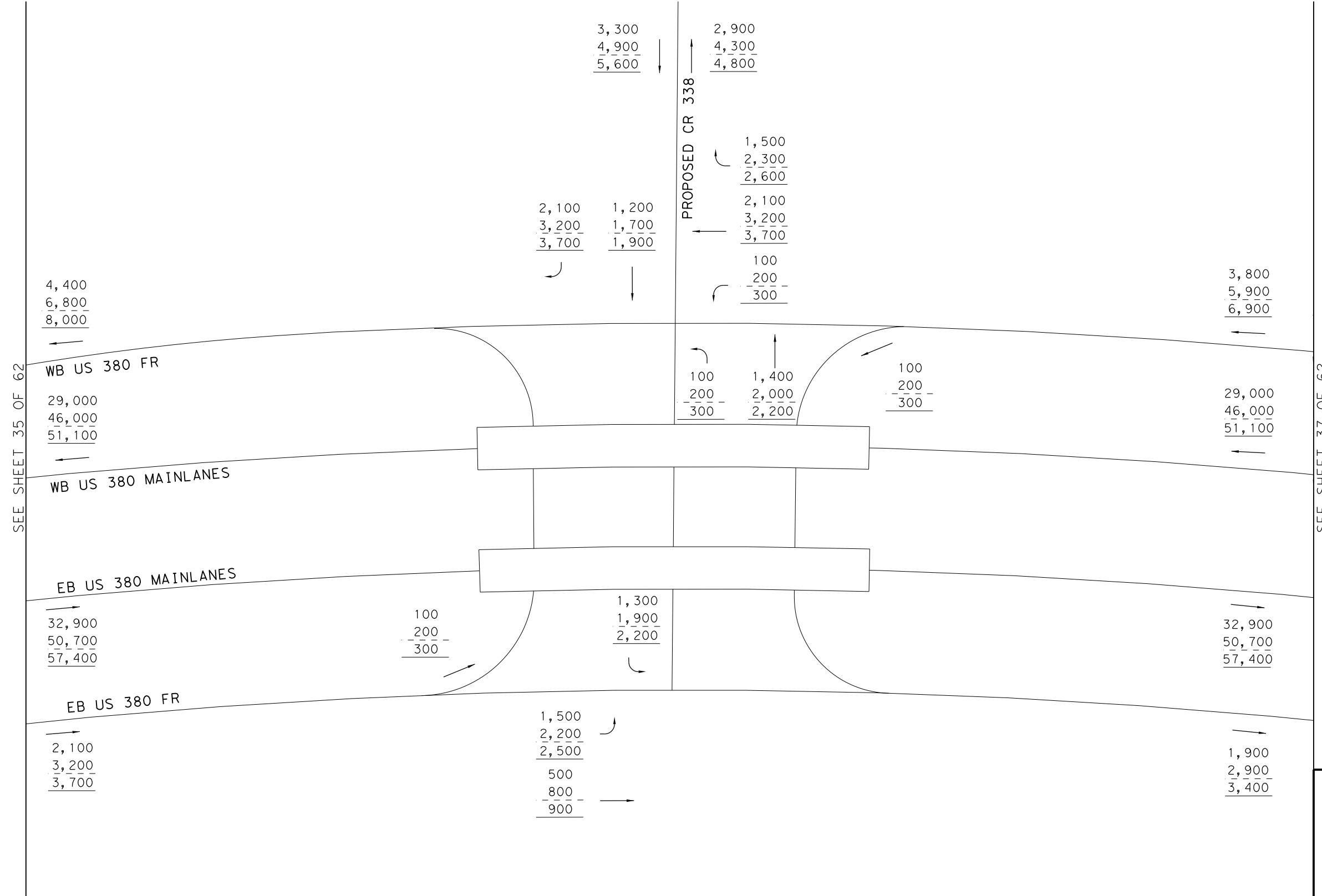
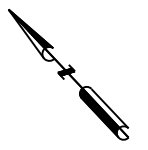


0135-02-065,
 ETC. SHEET 35 OF 62

LEGEND

- XXXX- 2030 AVERAGE DAILY TRAFFIC VOLUMES
- XXXX- 2050 AVERAGE DAILY TRAFFIC VOLUMES
- XXXX- 2060 AVERAGE DAILY TRAFFIC VOLUMES

DATE: 7/13/2021
 FILE: US380_BROWN_TRF_35.dgn



SEE SHEET 35 OF 62

SEE SHEET 37 OF 62

NOT TO SCALE

NOT INTENDED FOR CONSTRUCTION,
 BIDDING OR PERMIT PURPOSES
 DHRUVA LAHON, P.E.
 SERIAL NUMBER 102185

US 380 BROWN ALT AND
 CR 338
 AVERAGE DAILY TRAFFIC
 BROWN ALT BUILD VOLUMES

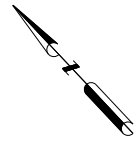


0135-02-065,
 ETC. SHEET 36 OF 62

LEGEND

- XXXX- 2030 AVERAGE DAILY TRAFFIC VOLUMES
- XXXX- 2050 AVERAGE DAILY TRAFFIC VOLUMES
- XXXX- 2060 AVERAGE DAILY TRAFFIC VOLUMES

DATE: 7/13/2021
 FILE: US380_BROWN_TRF_36.dgn



3,800
5,900
6,900

SEE SHEET 36 OF 62

WB US 380 FR
29,000
46,000
51,100

~~7,900~~ 2900
~~11,900~~ 4600
~~15,500~~ 5100

ENTRANCE FROM CR 331

WB US 380 MAINLANES

6700 ~~11,700~~
10500 ~~17,800~~
12000 ~~20,400~~

26100 ~~21,100~~
41400 ~~34,100~~
46000 ~~37,600~~

SEE SHEET 38 OF 62

EB US 380 MAINLANES

32,900
50,700
57,400

6,600
9,900
11,300

EXIT TO CR 331

26,300
40,800
46,100

EB US 380 FR

1,900
2,900
3,400

8,500
12,800
14,700

NOT TO SCALE

NOT INTENDED FOR CONSTRUCTION,
BIDDING OR PERMIT PURPOSES
DHURVA LAHON, P.E.
SERIAL NUMBER 102185

US 380 BROWN ALT AND
RAMPS
AVERAGE DAILY TRAFFIC
BROWN ALT BUILD VOLUMES

Kimley»Horn
F-928

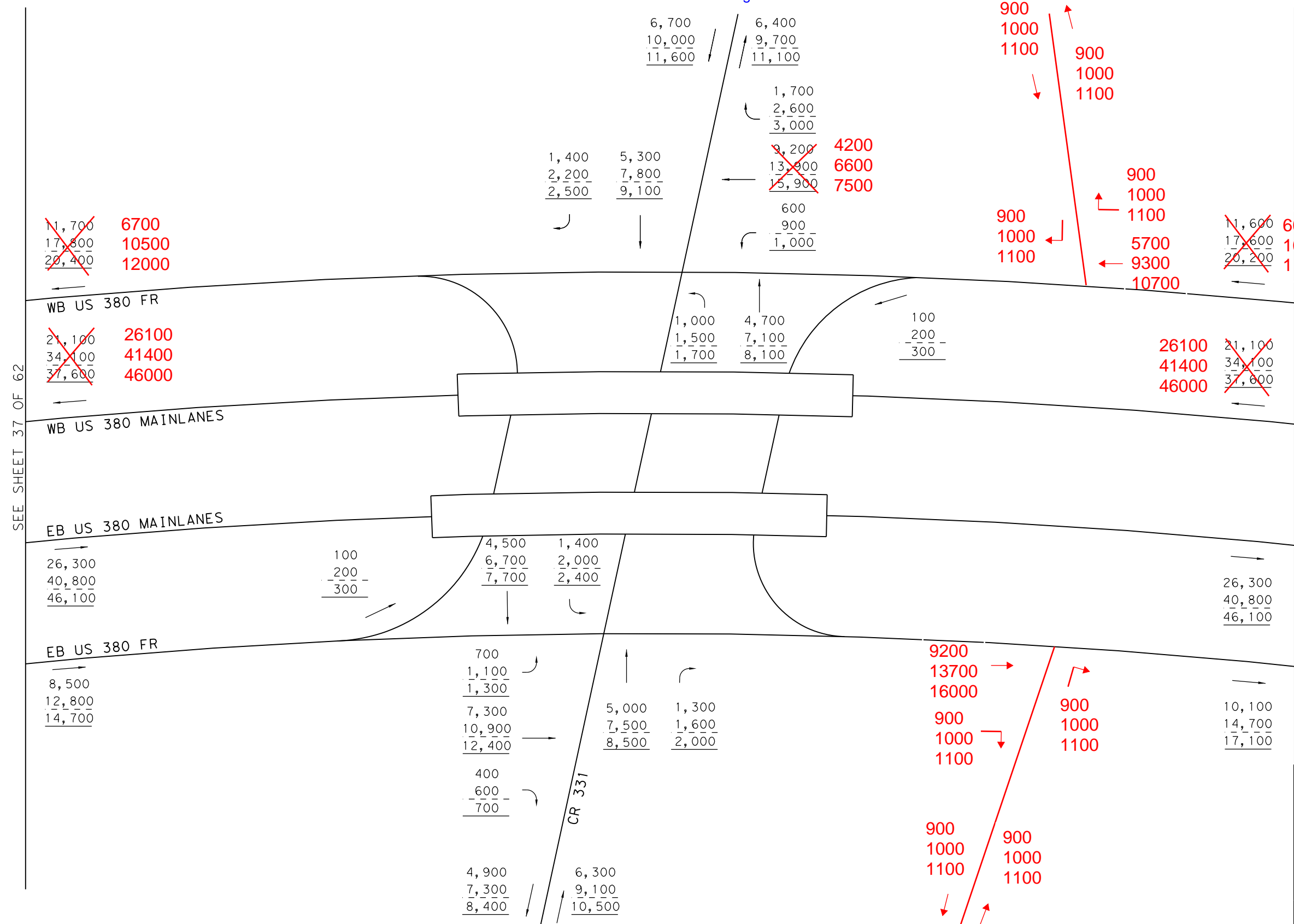
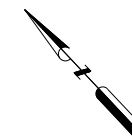
0135-02-065,
ETC. SHEET 37 OF 62

LEGEND

- XXXX- 2030 AVERAGE DAILY TRAFFIC VOLUMES
- XXXX- 2050 AVERAGE DAILY TRAFFIC VOLUMES
- XXXX- 2060 AVERAGE DAILY TRAFFIC VOLUMES

DATE: 7/13/2021
FILE: US380_BROWN_TRF_37.dgn

The interchange is being built by the City where it shows only U-turns in Schematic. So leave the interchange volumes.



SEE SHEET 37 OF 62

SEE SHEET 39 OF 62

~~11,700~~ 6700
~~17,800~~ 10500
~~20,400~~ 12000

~~21,100~~ 26100
~~34,100~~ 41400
~~37,600~~ 46000

WB US 380 FR

WB US 380 MAINLANES

EB US 380 FR

26,300
 40,800
 46,100

8,500
 12,800
 14,700

LEGEND

- XXXX- 2030 AVERAGE DAILY TRAFFIC VOLUMES
- XXXX- 2050 AVERAGE DAILY TRAFFIC VOLUMES
- XXXX- 2060 AVERAGE DAILY TRAFFIC VOLUMES

900
 1000
 1100

900
 1000
 1100

1,400 5,300
 2,200 7,800
 2,500 9,100

1,700
 2,600
 3,000

~~3,200~~ 4200
~~13,900~~ 6600
~~15,900~~ 7500

600
 900
 1,000

900
 1000
 1100

900
 1000
 1100

5700
 9300
 10700

~~11,600~~ 6600
~~17,600~~ 10300
~~20,200~~ 11800

1,000 4,700
 1,500 7,100
 1,700 8,100

100
 200
 300

26100
 41400
 46000

~~21,100~~
~~34,100~~
~~37,600~~

4,500 1,400
 6,700 2,000
 7,700 2,400

100
 200
 300

26,300
 40,800
 46,100

700
 1,100
 1,300

5,000 1,300
 7,500 1,600
 8,500 2,000

9200
 13700
 16000

900
 1000
 1100

900
 1000
 1100

10,100
 14,700
 17,100

400
 600
 700

CR 331

4,900 6,300
 7,300 9,100
 8,400 10,500

900
 1000
 1100

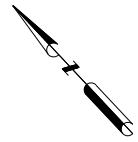
900
 1000
 1100

NOT TO SCALE

NOT INTENDED FOR CONSTRUCTION,
 BIDDING OR PERMIT PURPOSES
 DHRUVA LAHON, P.E.
 SERIAL NUMBER 102185

US 380 BROWN ALT AND
 CR 331
 AVERAGE DAILY TRAFFIC
 BROWN ALT BUILD VOLUMES





SEE SHEET 38 OF 62

SEE SHEET 40 OF 62

11,600	6600
17,600	10300
20,200	11800

3600	8,600
5800	13,100
6700	15,100

WB US 380 FR

21,100	26100
34,100	41400
37,600	46000

29100	24,100
45900	38,600
51100	42,700

EXIT TO CR 331

3,000
<u>4,500</u>
<u>5,100</u>

WB US 380 MAINLANES

EB US 380 MAINLANES

26,300
<u>40,800</u>
<u>46,100</u>

30,100
<u>46,500</u>
<u>52,600</u>

ENTRANCE FROM CR 331

3,800
<u>5,700</u>
<u>6,500</u>

EB US 380 FR

10,100
<u>14,700</u>
<u>17,100</u>

6,300
<u>9,000</u>
<u>10,600</u>

NOT TO SCALE

NOT INTENDED FOR CONSTRUCTION,
BIDDING OR PERMIT PURPOSES
DHURVA LAHON, P.E.
SERIAL NUMBER 102185

US 380 BROWN ALT AND
RAMPS
AVERAGE DAILY TRAFFIC
BROWN ALT BUILD VOLUMES

Kimley»Horn
F-928

0135-02-065,
ETC. SHEET 39 OF 62

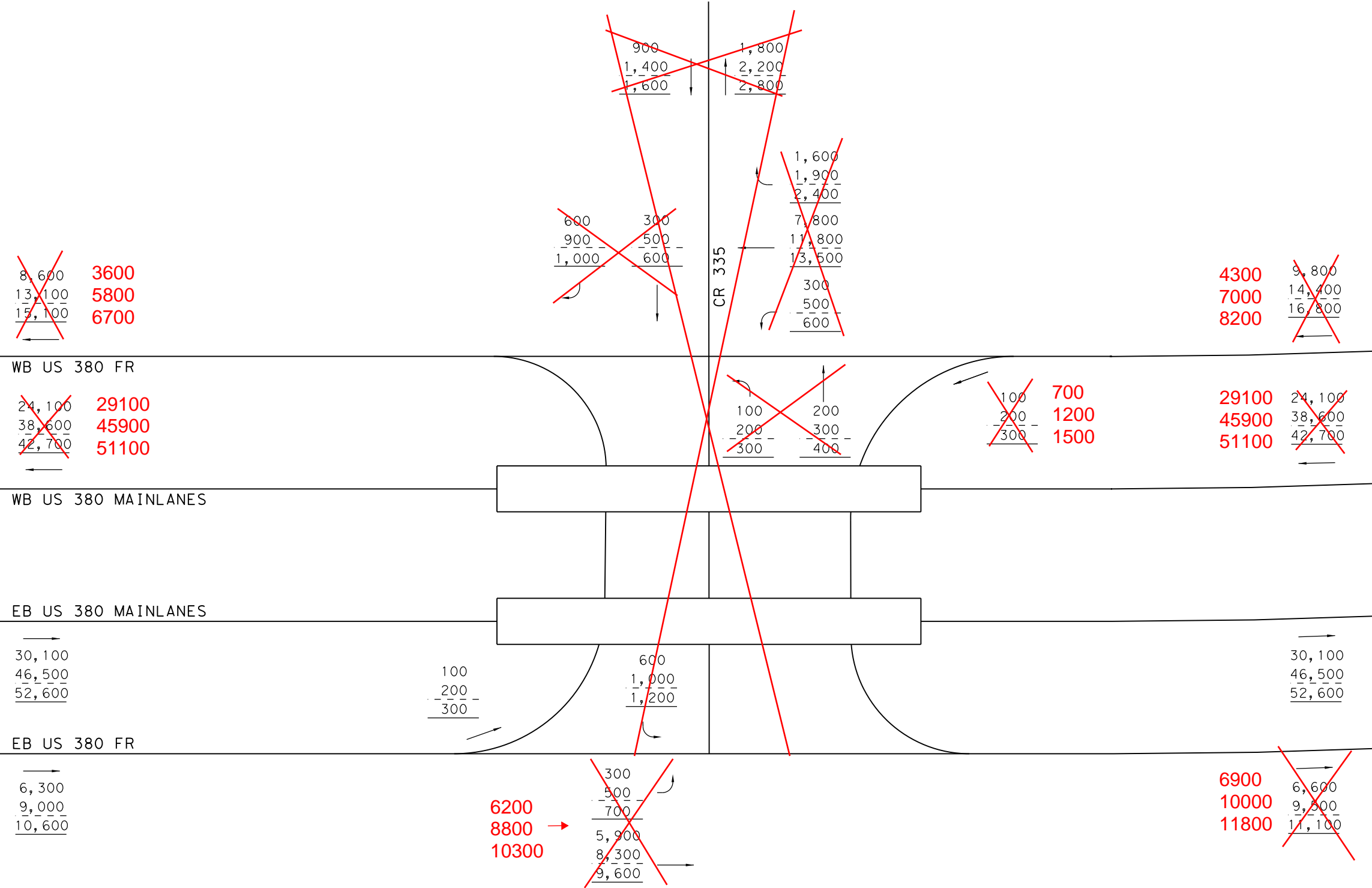
LEGEND

- XXXX- 2030 AVERAGE DAILY TRAFFIC VOLUMES
- XXXX- 2050 AVERAGE DAILY TRAFFIC VOLUMES
- XXXX- 2060 AVERAGE DAILY TRAFFIC VOLUMES



SEE SHEET 39 OF 62

SEE SHEET 40A OF 62



LEGEND

- XXXX- 2030 AVERAGE DAILY TRAFFIC VOLUMES
- XXXX- 2050 AVERAGE DAILY TRAFFIC VOLUMES
- XXXX- 2060 AVERAGE DAILY TRAFFIC VOLUMES

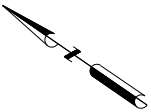
NOT TO SCALE

NOT INTENDED FOR CONSTRUCTION,
 BIDDING OR PERMIT PURPOSES
 DHRUVA LAHON, P.E.
 SERIAL NUMBER 102185

US 380 BROWN ALT AND
 CR 335
 AVERAGE DAILY TRAFFIC
 BROWN ALT BUILD VOLUMES

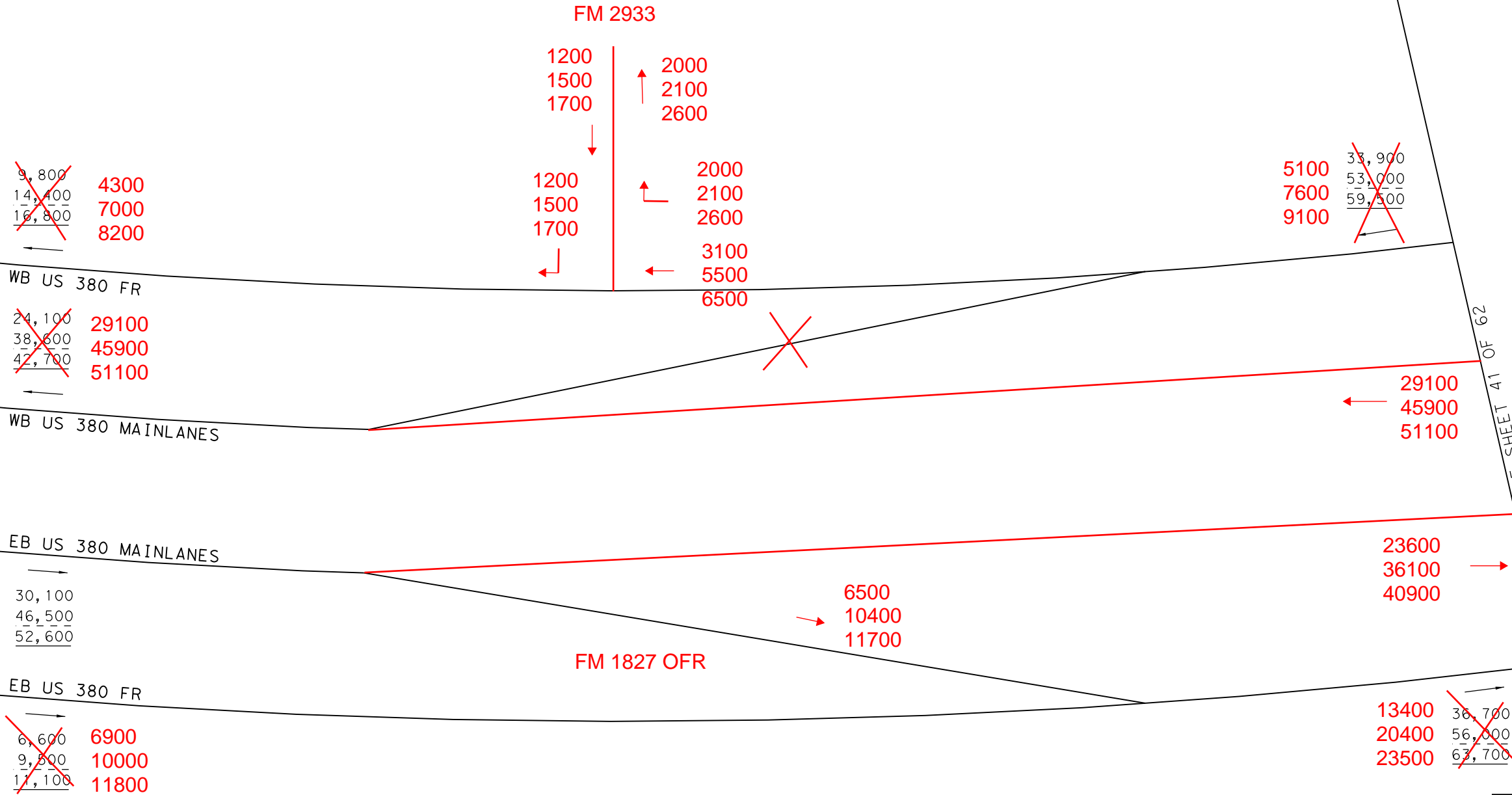


DATE: 7/13/2021
FILE: US380_BROWN_TRF_40.dgn



SEE SHEET 40 OF 62

SEE SHEET 41 OF 62



NOT TO SCALE

NOT INTENDED FOR CONSTRUCTION,
BIDDING OR PERMIT PURPOSES
DHURVA LAHON, P.E.
SERIAL NUMBER 102185

US 380 BROWN ALT AND
RAMPS
AVERAGE DAILY TRAFFIC
BROWN ALT BUILD VOLUMES

Kimley»Horn
F-928

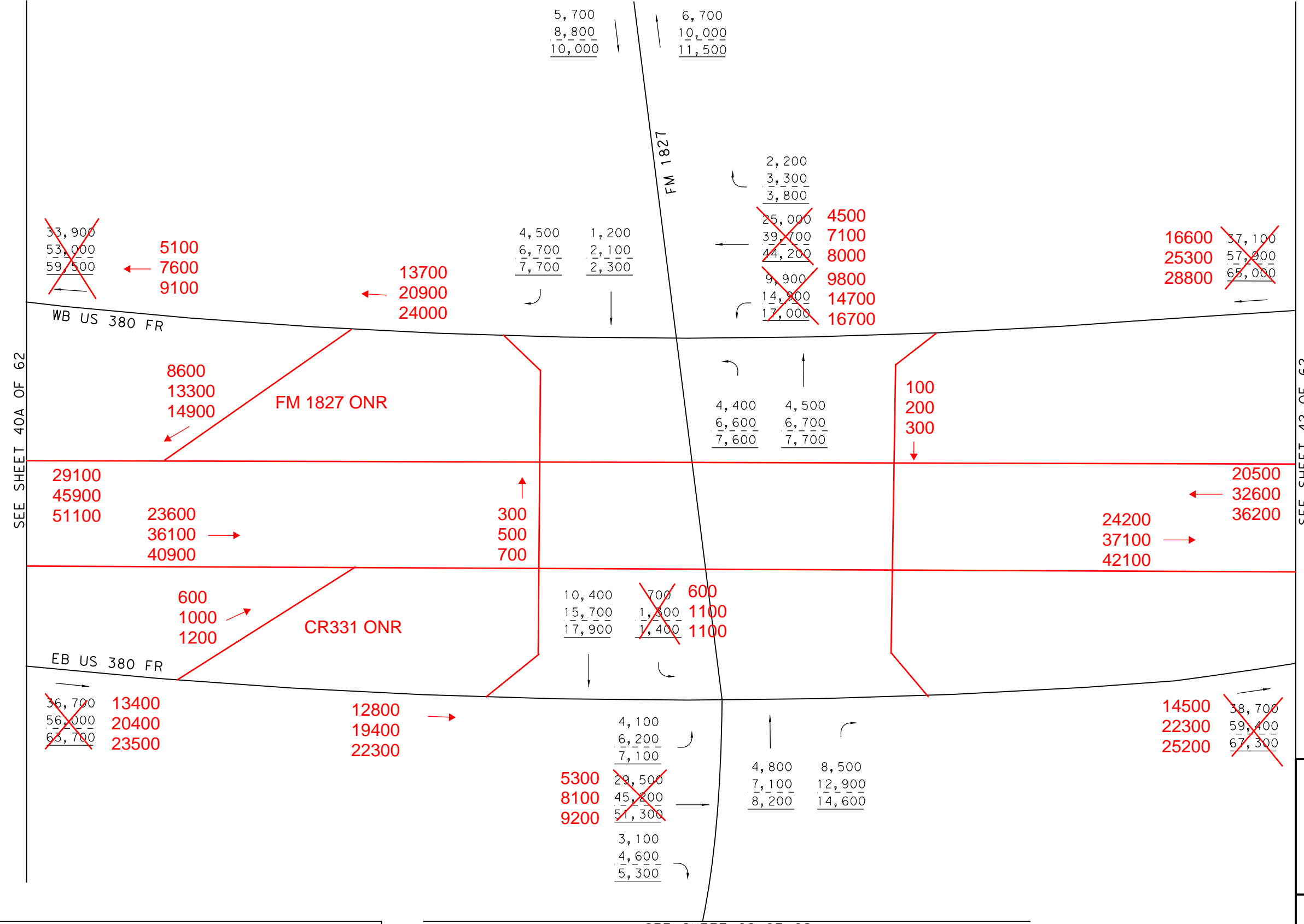
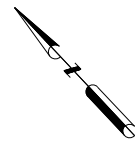
0135-02-065,
ETC. SHEET 40A OF 62

LEGEND

- XXXX- 2030 AVERAGE DAILY TRAFFIC VOLUMES
- XXXX- 2050 AVERAGE DAILY TRAFFIC VOLUMES
- XXXX- 2060 AVERAGE DAILY TRAFFIC VOLUMES

NOTE: SEE US 380 PRINCETON PROJECT
FOR US 380, FROM FM 1827 EASTWARD

DATE: 7/13/2021
FILE: US380_BROWN_TRF_40A.dgn



SEE SHEET 40A OF 62

SEE SHEET 42 OF 62

SEE SHEET 62 OF 62

NOT TO SCALE

NOT INTENDED FOR CONSTRUCTION,
 BIDDING OR PERMIT PURPOSES
 DHRUVA LAHON, P.E.
 SERIAL NUMBER 102185

US 380 BROWN ALT AND
 NEW HOPE RD/ FM 1827
 AVERAGE DAILY TRAFFIC
 BROWN ALT BUILD VOLUMES



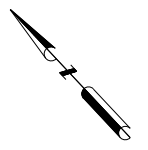
0135-02-065,
 ETC. SHEET 41 OF 62

LEGEND

- XXXX- 2030 AVERAGE DAILY TRAFFIC VOLUMES
- XXXX- 2050 AVERAGE DAILY TRAFFIC VOLUMES
- XXXX- 2060 AVERAGE DAILY TRAFFIC VOLUMES

NOTE: SEE US 380 PRINCETON PROJECT
 FOR US 380 FROM FM 1827 EASTWARD

DATE: 7/13/2021
 FILE: US380_BROWN_TRF_41.dgn



SEE SHEET 41 OF 62

37,100	16600
57,900	25300
65,000	28800

37,100
57,900
65,000

FM 1827 OFR

WB US 380 MAINLANES
EB US 380 MAINLANES

←	20500
←	32600
←	36200

38,700
59,400
67,300

24200	→
37100	→
42100	→

FM 1827 ONR

38,700	14500
59,400	22300
67,300	25200

NOT TO SCALE

NOT INTENDED FOR CONSTRUCTION,
BIDDING OR PERMIT PURPOSES
DHURVA LAHON, P.E.
SERIAL NUMBER 102185

US 380 BROWN ALT AND
RAMPS
AVERAGE DAILY TRAFFIC
BROWN ALT BUILD VOLUMES



0135-02-065,
ETC. SHEET 42 OF 62

LEGEND

XXXX-	2030	AVERAGE	DAILY	TRAFFIC	VOLUMES
-XXXX-	2050	AVERAGE	DAILY	TRAFFIC	VOLUMES
XXXX-	2060	AVERAGE	DAILY	TRAFFIC	VOLUMES

NOTE: SEE US 380 PRINCETON PROJECT FOR US 380, FROM FM 1825 EASTWARD

DATE: 7/13/2021
FILE: US380_BROWN_TRF_42.dgn



SEE SHEET 4 OF 62

SEE SHEET 44 OF 62

WB US 380 EXISTING
EB US 380 EXISTING

CUSTER ROAD

11,600
17,800
20,100

9,800
14,900
16,400

2,500 7,800 3,900
3,900 12,000 6,000
4,400 13,600 6,800

14,200
21,900
24,800

12,800
19,400
22,400

2,000
2,900
3,200
1,900
2,900
3,200
5,900
9,100
10,000

20,500
31,600
34,900

3,000
4,500
5,600
2,400
3,700
4,200
6,800
10,500
11,300

6,700 7,800 6,400
10,200 12,000 9,800
11,500 13,600 11,100

20,900
32,000
36,200

12,200
18,700
21,100

12,200
18,700
21,100

NOT TO SCALE

NOT INTENDED FOR CONSTRUCTION,
BIDDING OR PERMIT PURPOSES
DHURVA LAHON, P.E.
SERIAL NUMBER 102185

EXISTING US 380 AND
CUSTER RD
AVERAGE DAILY TRAFFIC

Kimley»Horn
F-928

0135-02-065,
ETC. SHEET 43 OF 62

LEGEND

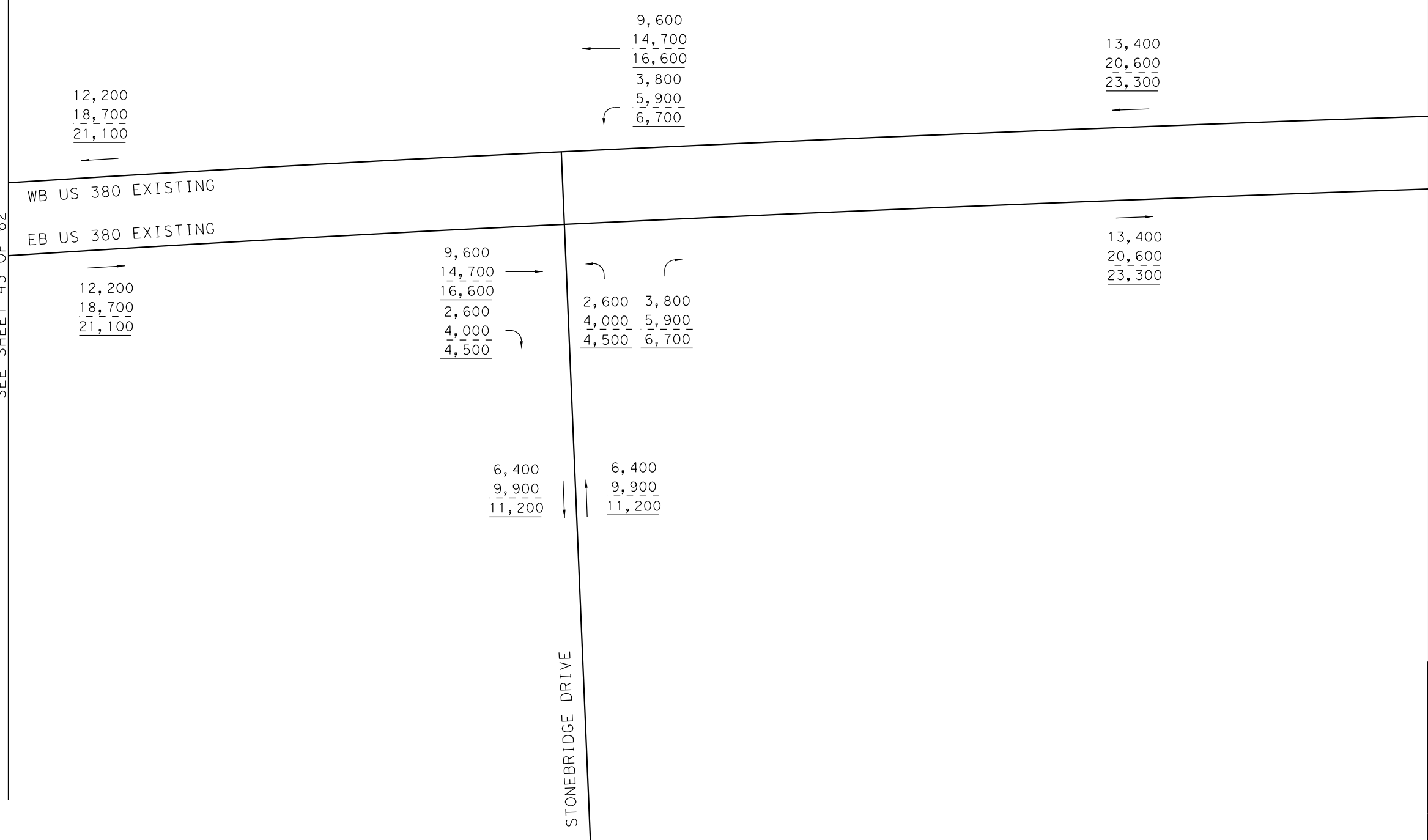
- XXXX- 2030 AVERAGE DAILY TRAFFIC VOLUMES
- XXXX- 2050 AVERAGE DAILY TRAFFIC VOLUMES
- XXXX- 2060 AVERAGE DAILY TRAFFIC VOLUMES

DATE: 7/13/2021
FILE: US380_BROWN_TRF_43.dgn



SEE SHEET 43 OF 62

SEE SHEET 45 OF 62



NOT TO SCALE

NOT INTENDED FOR CONSTRUCTION,
 BIDDING OR PERMIT PURPOSES
 DHRUVA LAHON, P.E.
 SERIAL NUMBER 102185

EXISTING US 380 AND
 STONEBRIDGE DR
 AVERAGE DAILY TRAFFIC

Kimley»Horn
F-928

0135-02-065,
 ETC. SHEET 44 OF 62

LEGEND

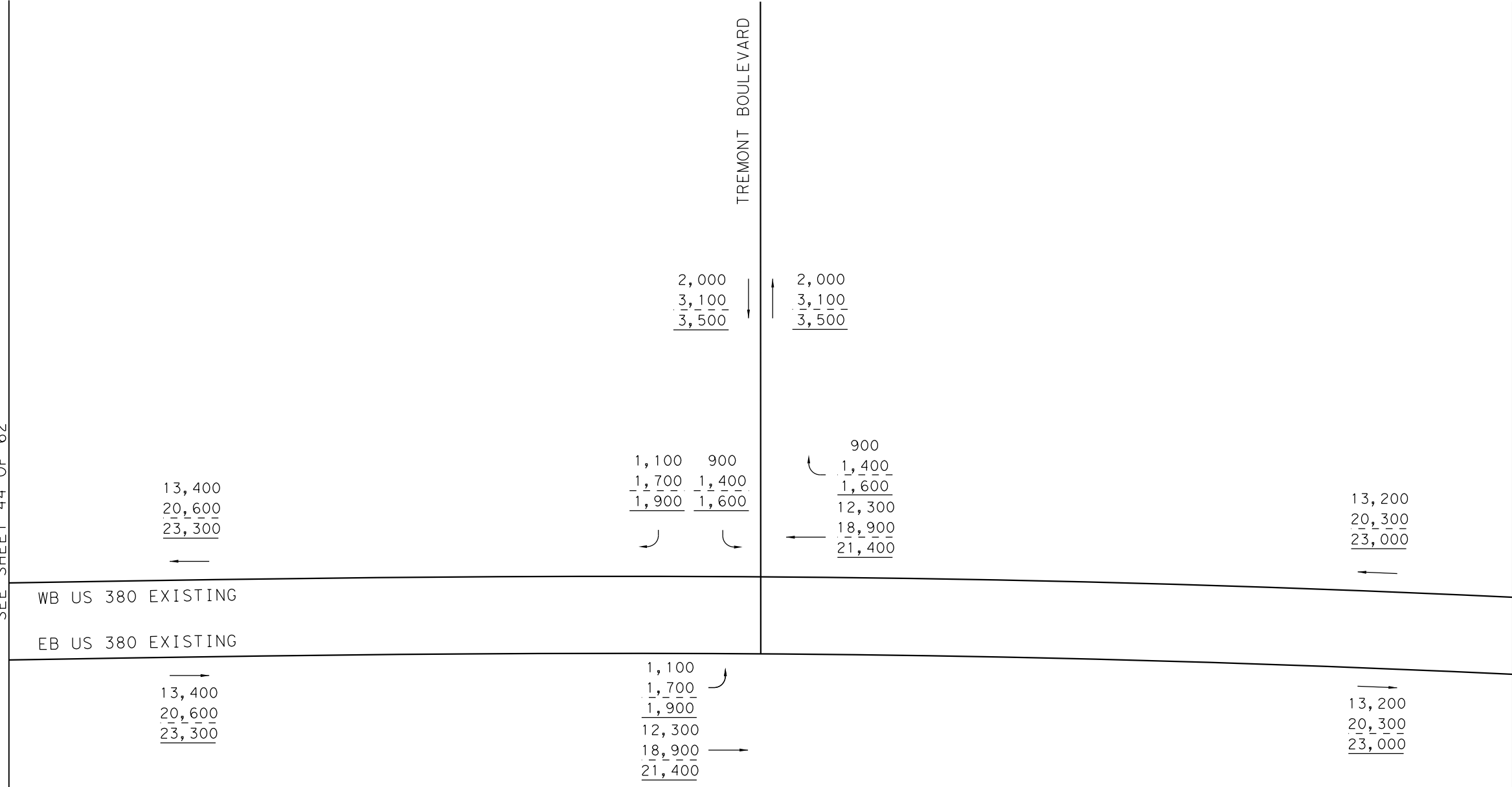
- XXXX- 2030 AVERAGE DAILY TRAFFIC VOLUMES
- XX- 2050 AVERAGE DAILY TRAFFIC VOLUMES
- XX- 2060 AVERAGE DAILY TRAFFIC VOLUMES

DATE: 7/13/2021
 FILE: US380_BROWN_TRF_44.dgn



SEE SHEET 44 OF 62

SEE SHEET 46 OF 62



WB US 380 EXISTING
EB US 380 EXISTING

TREMONT BOULEVARD

NOT TO SCALE

NOT INTENDED FOR CONSTRUCTION,
BIDDING OR PERMIT PURPOSES
DHURVA LAHON, P.E.
SERIAL NUMBER 102185

EXISTING US 380 AND
TREMONT BLVD
AVERAGE DAILY TRAFFIC

Kimley»Horn
F-928

0135-02-065,
ETC. SHEET 45 OF 62

LEGEND

- XXXX- 2030 AVERAGE DAILY TRAFFIC VOLUMES
- XXXX- 2050 AVERAGE DAILY TRAFFIC VOLUMES
- XXXX- 2060 AVERAGE DAILY TRAFFIC VOLUMES



SEE SHEET 45 OF 62

SEE SHEET 47 OF 62

WB US 380 EXISTING
EB US 380 EXISTING

13,200
20,300
22,900

11,300
17,300
19,600
4,400
6,800
7,700

15,700
24,100
27,300

13,200
20,300
22,900

10,600
16,300
18,300
2,600
4,000
4,600

1,900 4,700
3,000 7,300
3,300 8,200

15,300
23,600
26,500

7,000
10,800
12,300

6,600
10,300
11,500

RIDGE ROAD

NOT TO SCALE

NOT INTENDED FOR CONSTRUCTION,
BIDDING OR PERMIT PURPOSES
DHURVA LAHON, P.E.
SERIAL NUMBER 102185

EXISTING US 380 AND
RIDGE RD
AVERAGE DAILY TRAFFIC

Kimley»Horn
F-928

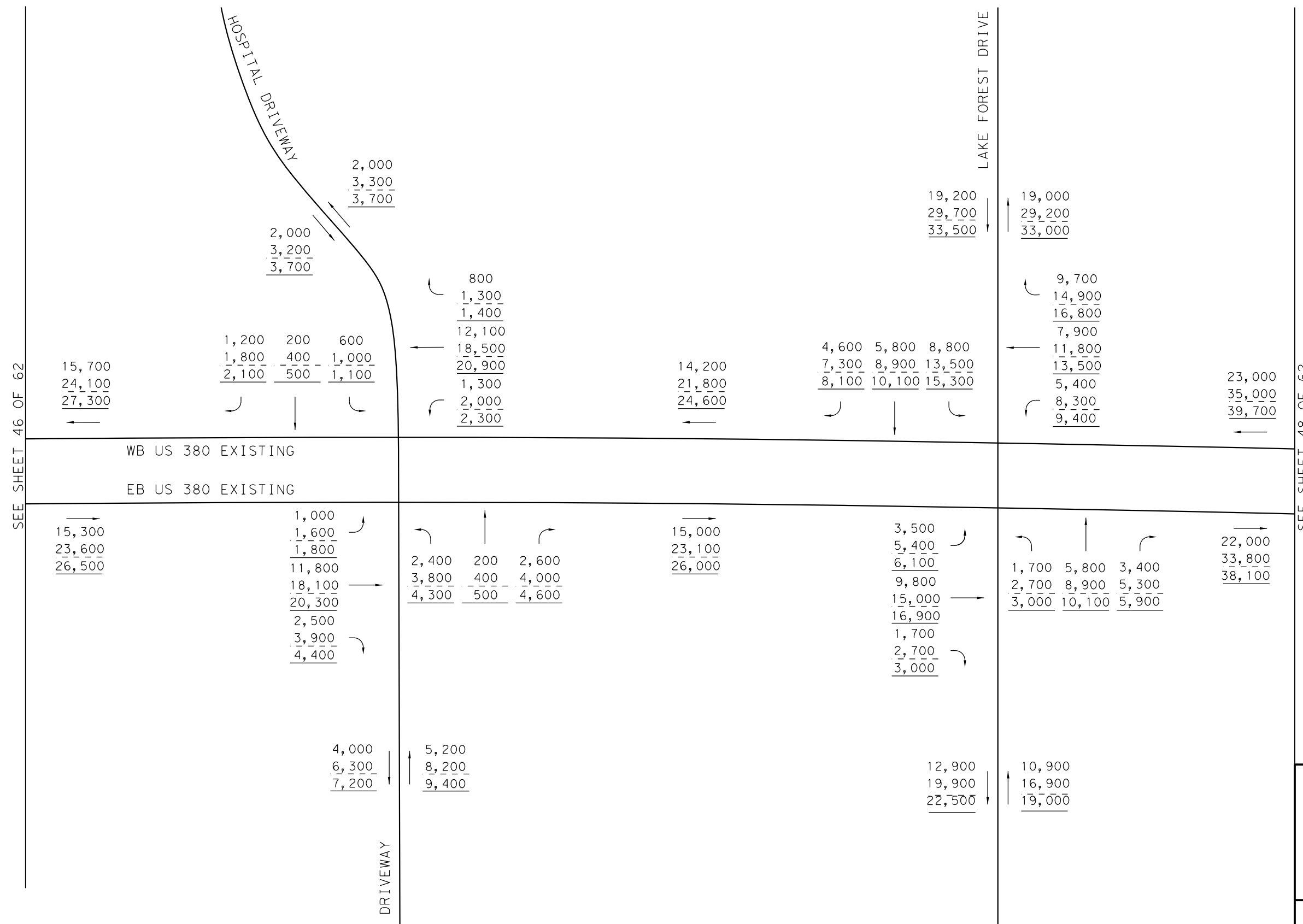
0135-02-065,
ETC.

SHEET 46 OF 62

LEGEND

- XXXX- 2030 AVERAGE DAILY TRAFFIC VOLUMES
- XXXX- 2050 AVERAGE DAILY TRAFFIC VOLUMES
- XXXX- 2060 AVERAGE DAILY TRAFFIC VOLUMES

DATE: 7/13/2021
FILE: US380_BROWN_TRF_46.dgn



SEE SHEET 46 OF 62

SEE SHEET 48 OF 62

WB US 380 EXISTING

EB US 380 EXISTING

NOT TO SCALE

NOT INTENDED FOR CONSTRUCTION,
BIDDING OR PERMIT PURPOSES
DHURVA LAHON, P.E.
SERIAL NUMBER 102185

EXISTING US 380 AND
LAKE FOREST DR
AVERAGE DAILY TRAFFIC

Kimley»Horn
F-928

0135-02-065,
ETC. SHEET 47 OF 62

LEGEND

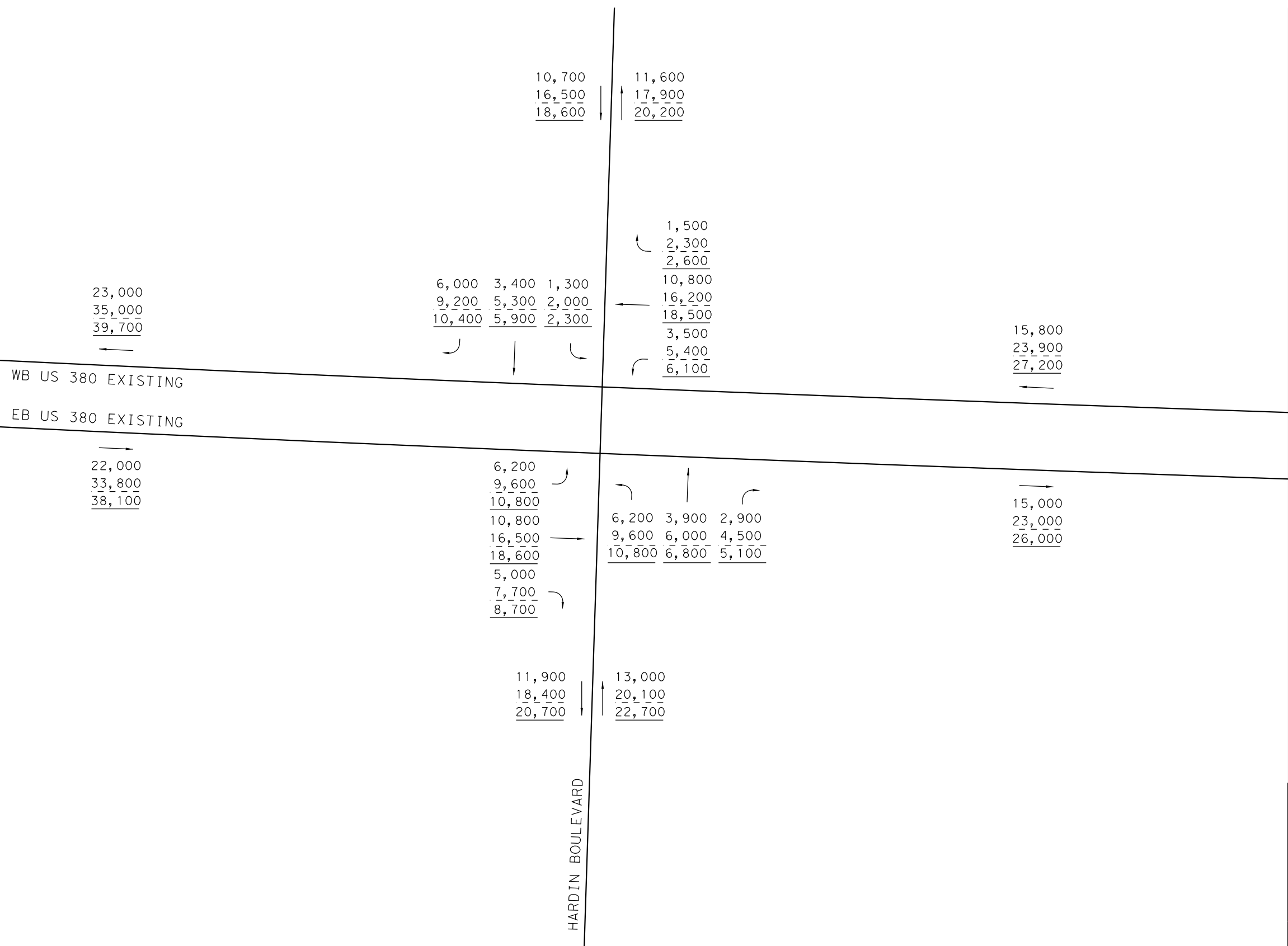
- XXXX- 2030 AVERAGE DAILY TRAFFIC VOLUMES
- XXXX- 2050 AVERAGE DAILY TRAFFIC VOLUMES
- XXXX- 2060 AVERAGE DAILY TRAFFIC VOLUMES

DATE: 7/13/2021
FILE: US380_BROWN_TRF_47.dgn



SEE SHEET 47 OF 62

SEE SHEET 49 OF 62



HARDIN BOULEVARD

WB US 380 EXISTING
EB US 380 EXISTING

NOT TO SCALE

NOT INTENDED FOR CONSTRUCTION,
BIDDING OR PERMIT PURPOSES
DHURVA LAHON, P.E.
SERIAL NUMBER 102185

EXISTING US 380 AND
HARDIN BLVD
AVERAGE DAILY TRAFFIC

Kimley»Horn
F-928

0135-02-065,
ETC. SHEET 48 OF 62

LEGEND

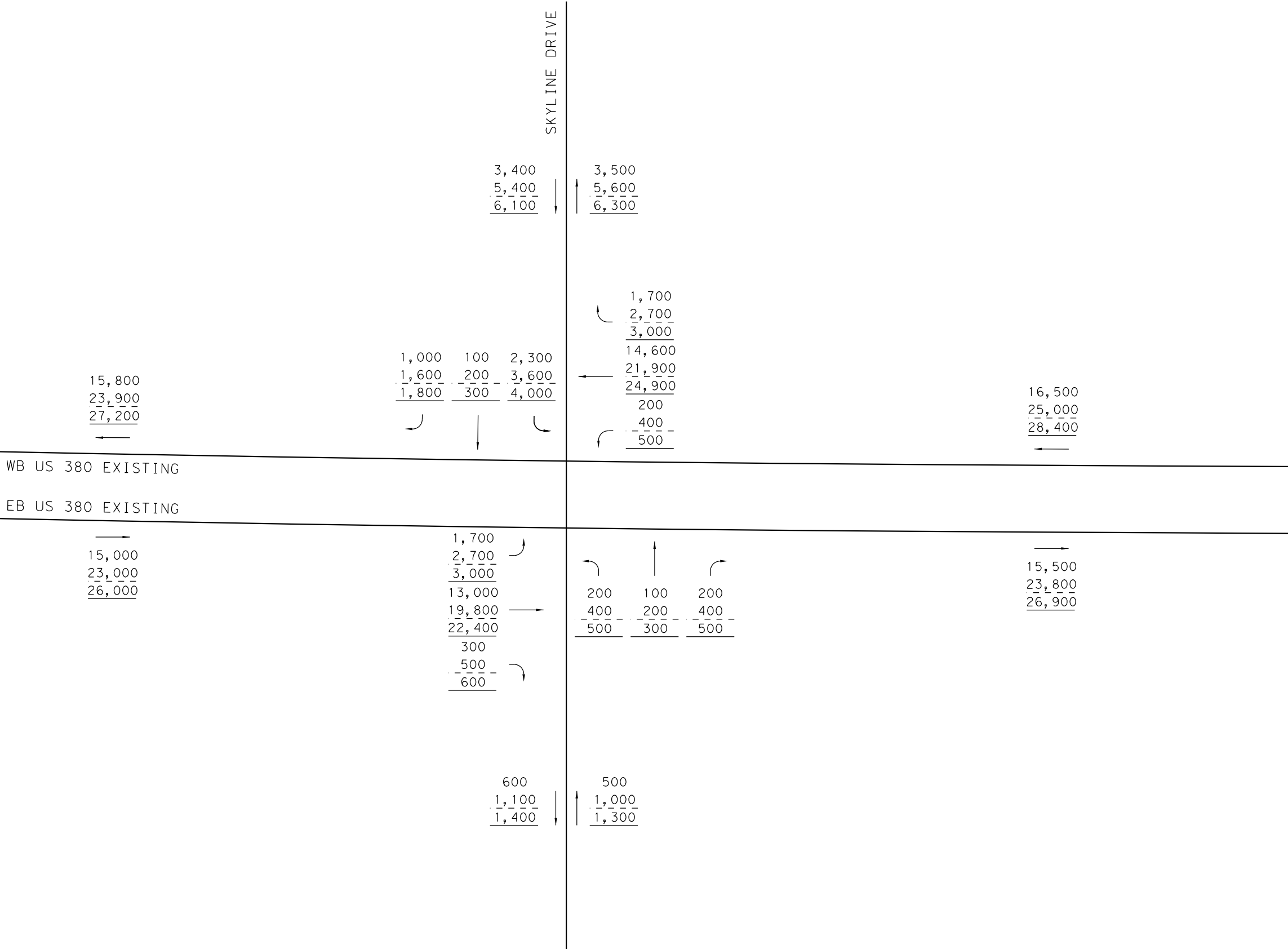
- XXXX- 2030 AVERAGE DAILY TRAFFIC VOLUMES
- XXXX- 2050 AVERAGE DAILY TRAFFIC VOLUMES
- XXXX- 2060 AVERAGE DAILY TRAFFIC VOLUMES

DATE: 7/13/2021
FILE: US380_BROWN_TRF_48.dgn



SEE SHEET 48 OF 62

SEE SHEET 50 OF 62



WB US 380 EXISTING
EB US 380 EXISTING

NOT TO SCALE

NOT INTENDED FOR CONSTRUCTION,
BIDDING OR PERMIT PURPOSES
DHURVA LAHON, P.E.
SERIAL NUMBER 102185

EXISTING US 380 AND
SKYLINE DR
AVERAGE DAILY TRAFFIC

Kimley»Horn

0135-02-065, ETC. SHEET 49 OF 62

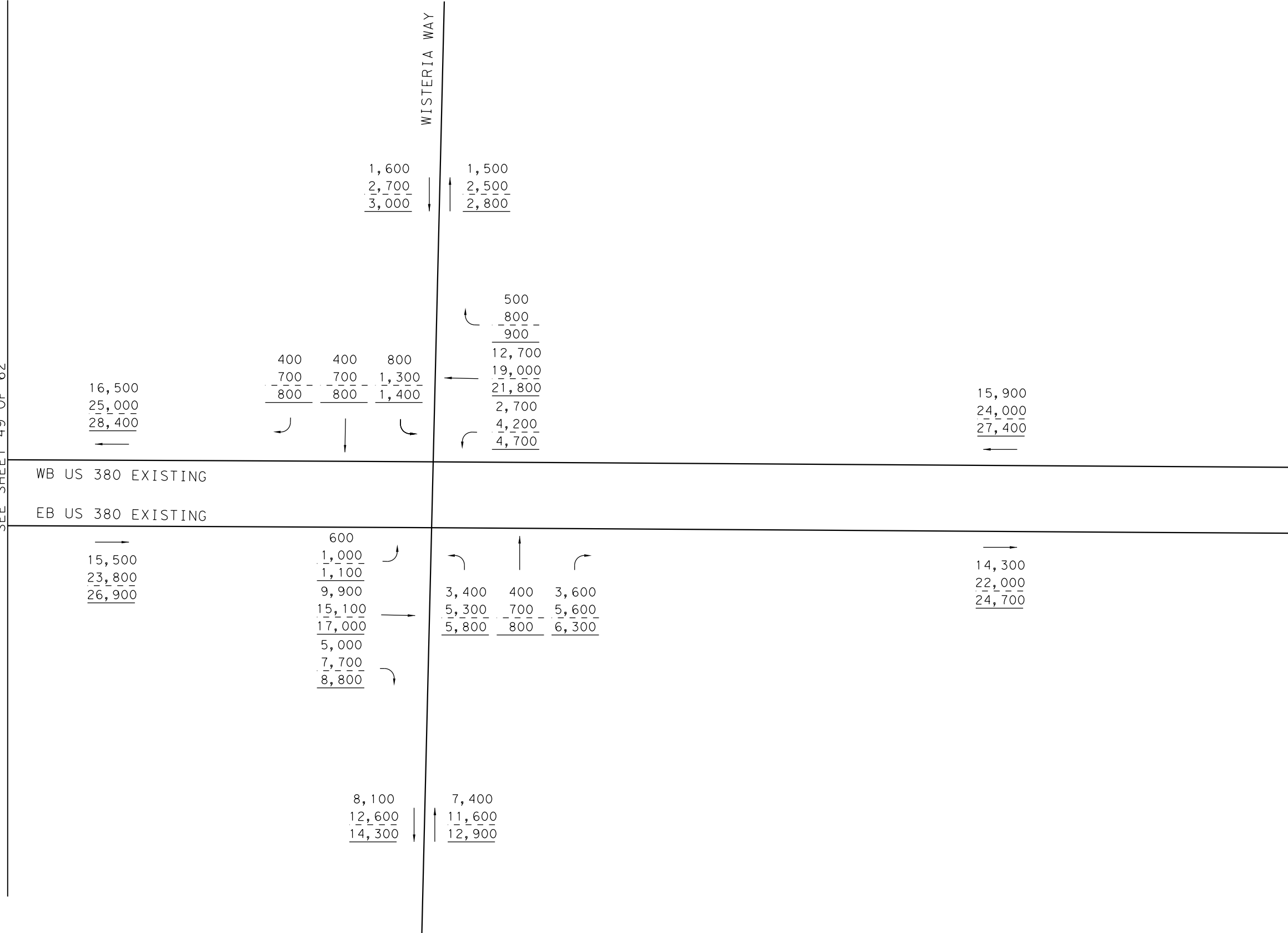
DATE: 7/13/2021
FILE: US380_BROWN_TRF_49.dgn

LEGEND	
XXXX-	2030 AVERAGE DAILY TRAFFIC VOLUMES
-XXXX-	2050 AVERAGE DAILY TRAFFIC VOLUMES
XXXX-	2060 AVERAGE DAILY TRAFFIC VOLUMES



SEE SHEET 49 OF 62

SEE SHEET 51 OF 62



LEGEND

- XXXX- 2030 AVERAGE DAILY TRAFFIC VOLUMES
- XXXX- 2050 AVERAGE DAILY TRAFFIC VOLUMES
- XXXX- 2060 AVERAGE DAILY TRAFFIC VOLUMES

NOT INTENDED FOR CONSTRUCTION,
 BIDDING OR PERMIT PURPOSES
 DHRUVA LAHON, P.E.
 SERIAL NUMBER 102185

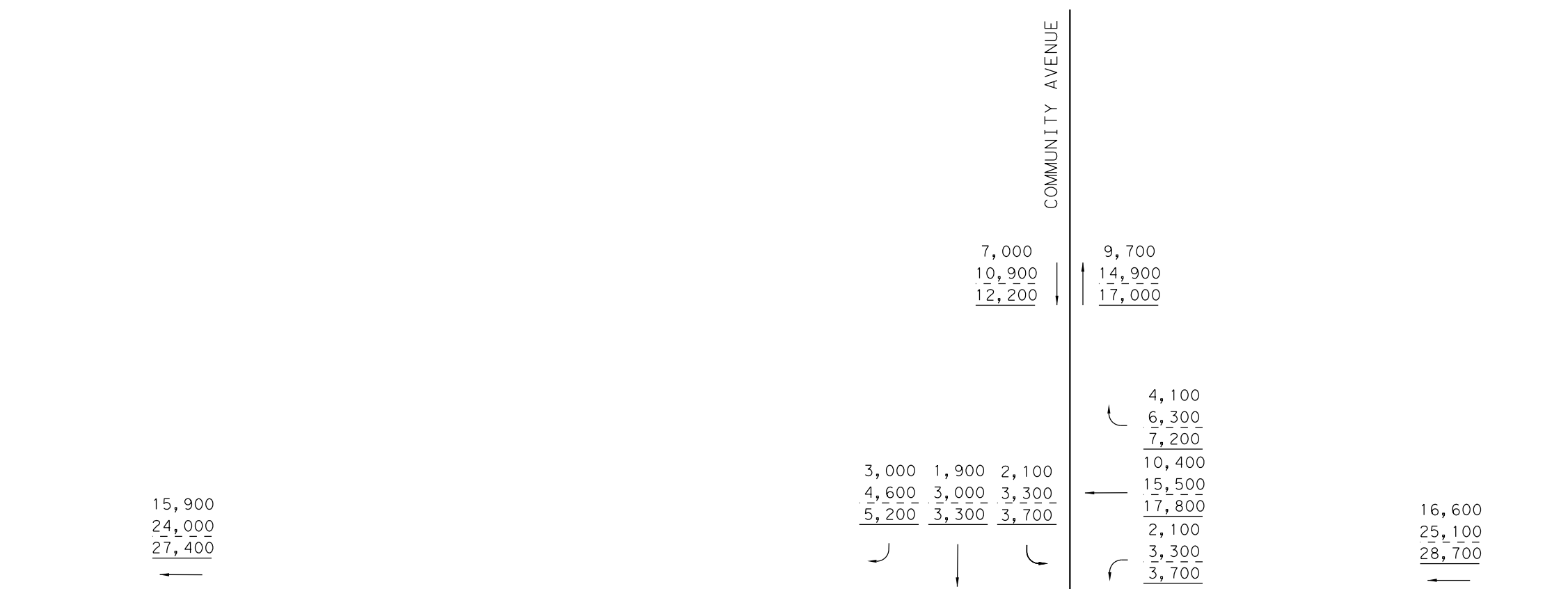
EXISTING US 380 AND
 WISTERIA WAY
 AVERAGE DAILY TRAFFIC





SEE SHEET 50 OF 62

SEE SHEET 52 OF 62



LEGEND

- XXXX- 2030 AVERAGE DAILY TRAFFIC VOLUMES
- XXXX- 2050 AVERAGE DAILY TRAFFIC VOLUMES
- XXXX- 2060 AVERAGE DAILY TRAFFIC VOLUMES

NOT TO SCALE

NOT INTENDED FOR CONSTRUCTION,
 BIDDING OR PERMIT PURPOSES
 DHRUVA LAHON, P.E.
 SERIAL NUMBER 102185

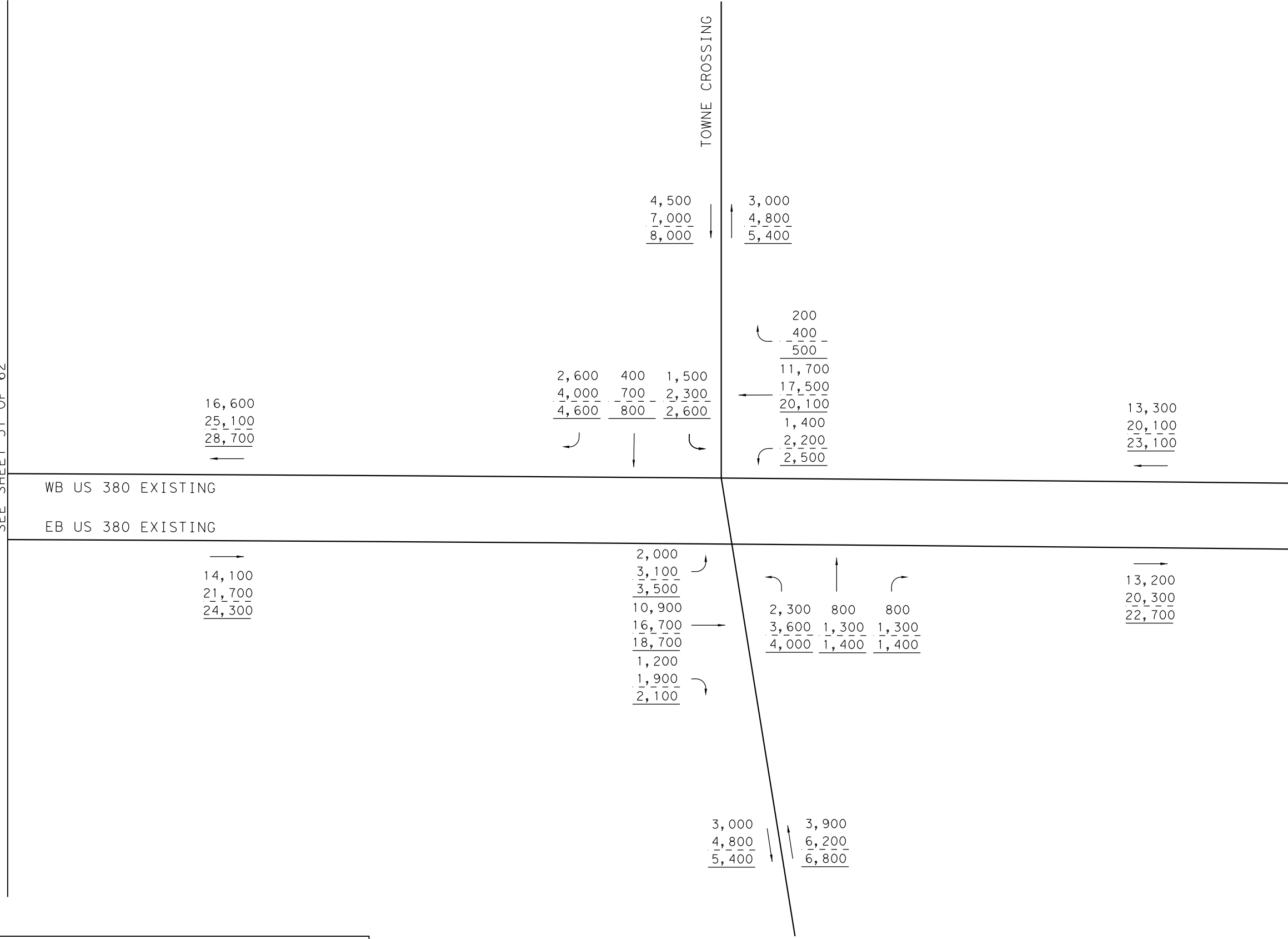
EXISTING US 380 AND
 COMMUNITY AVE
 AVERAGE DAILY TRAFFIC





SEE SHEET 51 OF 62

SEE SHEET 53 OF 62



WB US 380 EXISTING
 EB US 380 EXISTING

NOT TO SCALE

NOT INTENDED FOR CONSTRUCTION,
 BIDDING OR PERMIT PURPOSES
 DHRUVA LAHON, P.E.
 SERIAL NUMBER 102185

EXISTING US 380 AND
 TOWNE CROSSING
 AVERAGE DAILY TRAFFIC

Kimley»Horn
F-928

0135-02-065,
 ETC. SHEET 52 OF 62

LEGEND

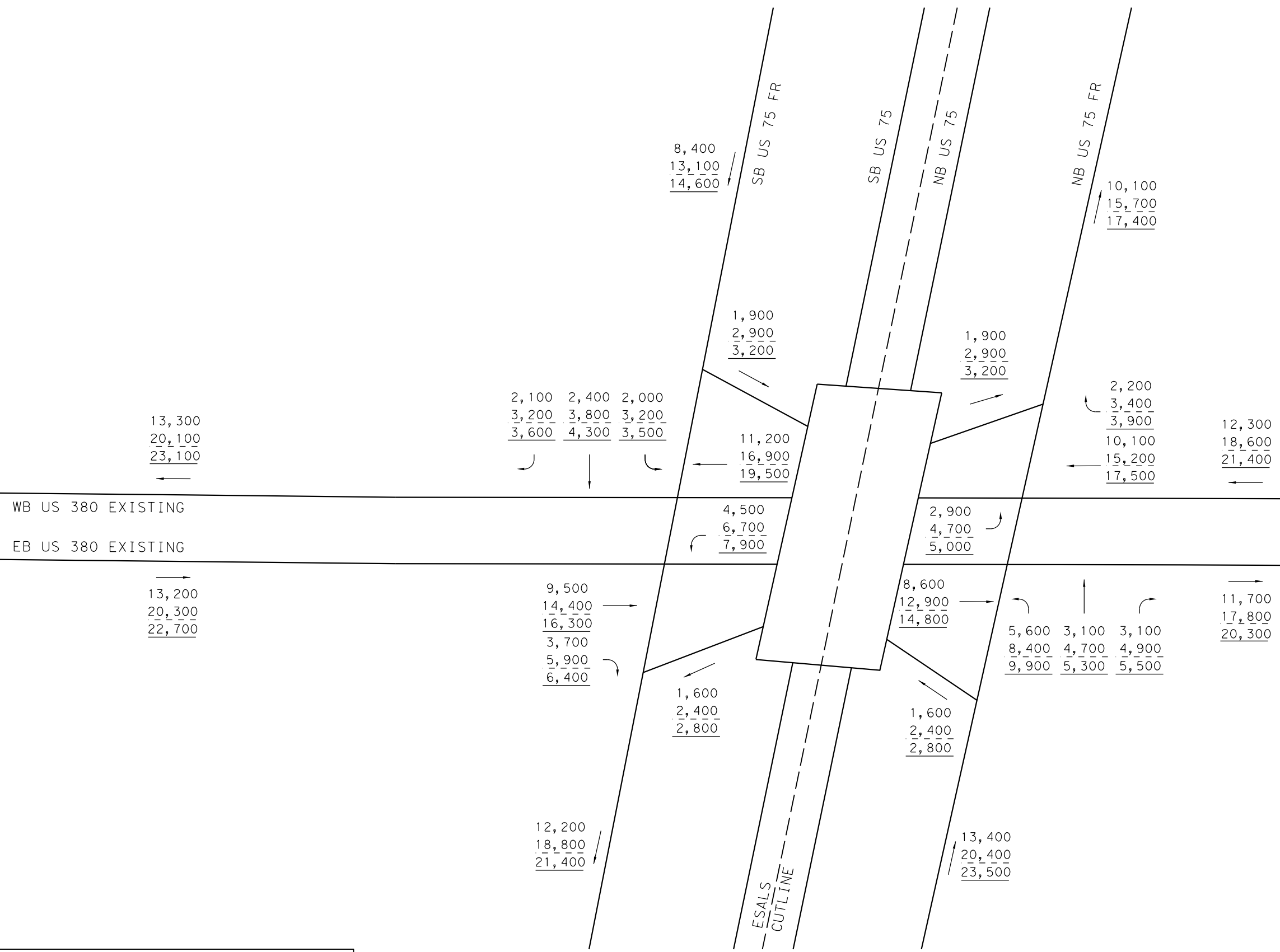
- XXXX- 2030 AVERAGE DAILY TRAFFIC VOLUMES
- XXXX- 2050 AVERAGE DAILY TRAFFIC VOLUMES
- XXXX- 2060 AVERAGE DAILY TRAFFIC VOLUMES

DATE: 7/13/2021
 FILE: US380_BROWN_TRF_52.dgn



SEE SHEET 52 OF 62

SEE SHEET 54 OF 62



LEGEND

- XXXX- 2030 AVERAGE DAILY TRAFFIC VOLUMES
- XXX- 2050 AVERAGE DAILY TRAFFIC VOLUMES
- XX- 2060 AVERAGE DAILY TRAFFIC VOLUMES

NOT TO SCALE

NOT INTENDED FOR CONSTRUCTION,
 BIDDING OR PERMIT PURPOSES
 DHRUVA LAHON, P.E.
 SERIAL NUMBER 102185

EXISTING US 380 AND US 75 AVERAGE DAILY TRAFFIC

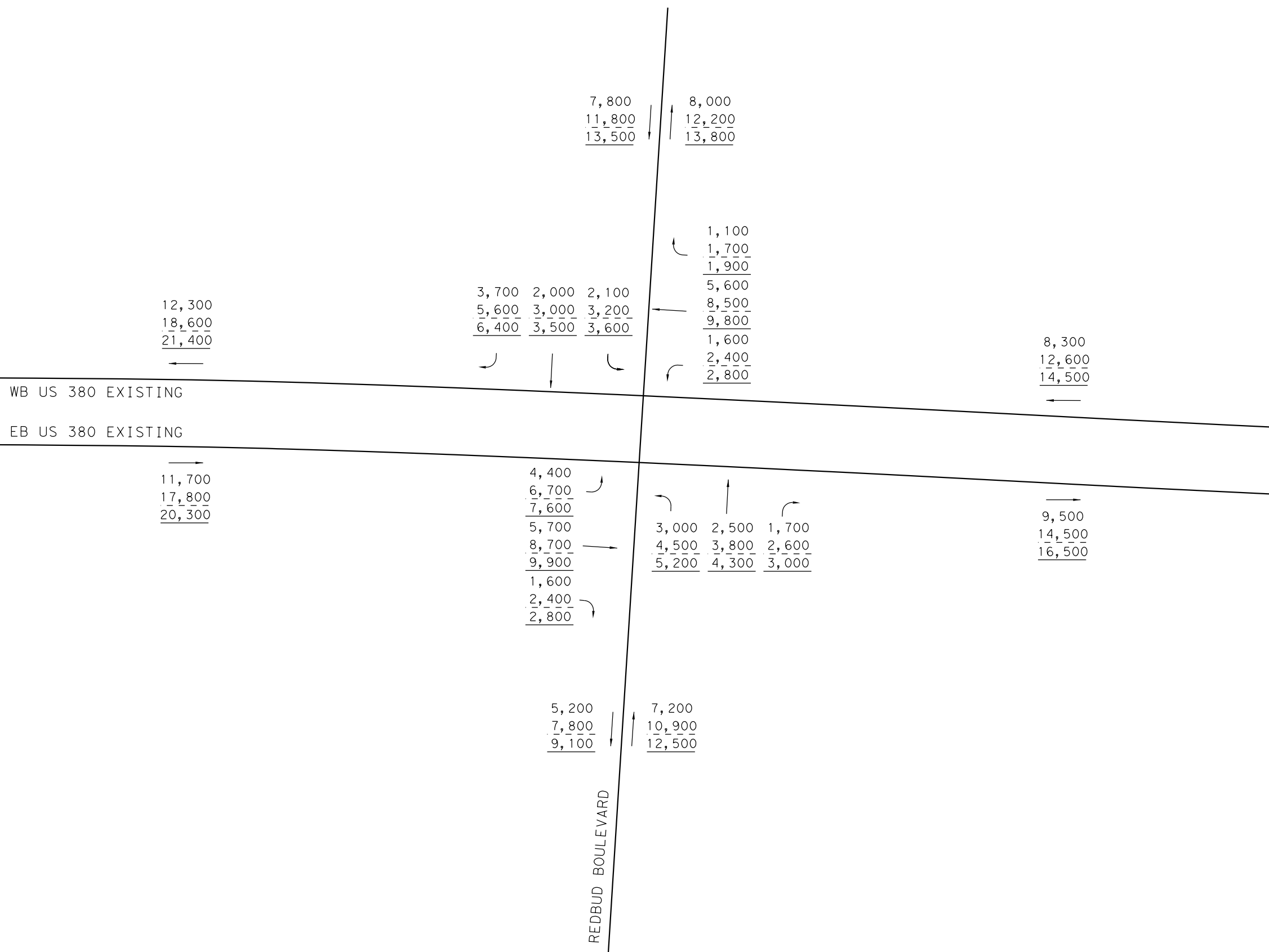


DATE: 7/13/2021 FILE: US380_BROWN_TRF_53.dgn



SEE SHEET 53 OF 62

SEE SHEET 55 OF 62



WB US 380 EXISTING
EB US 380 EXISTING

REDBUD BOULEVARD

NOT TO SCALE

NOT INTENDED FOR CONSTRUCTION,
BIDDING OR PERMIT PURPOSES
DHURVA LAHON, P.E.
SERIAL NUMBER 102185

EXISTING US 380 AND
REDBUD BLVD
AVERAGE DAILY TRAFFIC

Kimley»Horn
F-928

0135-02-065,
ETC. SHEET 54 OF 62

LEGEND

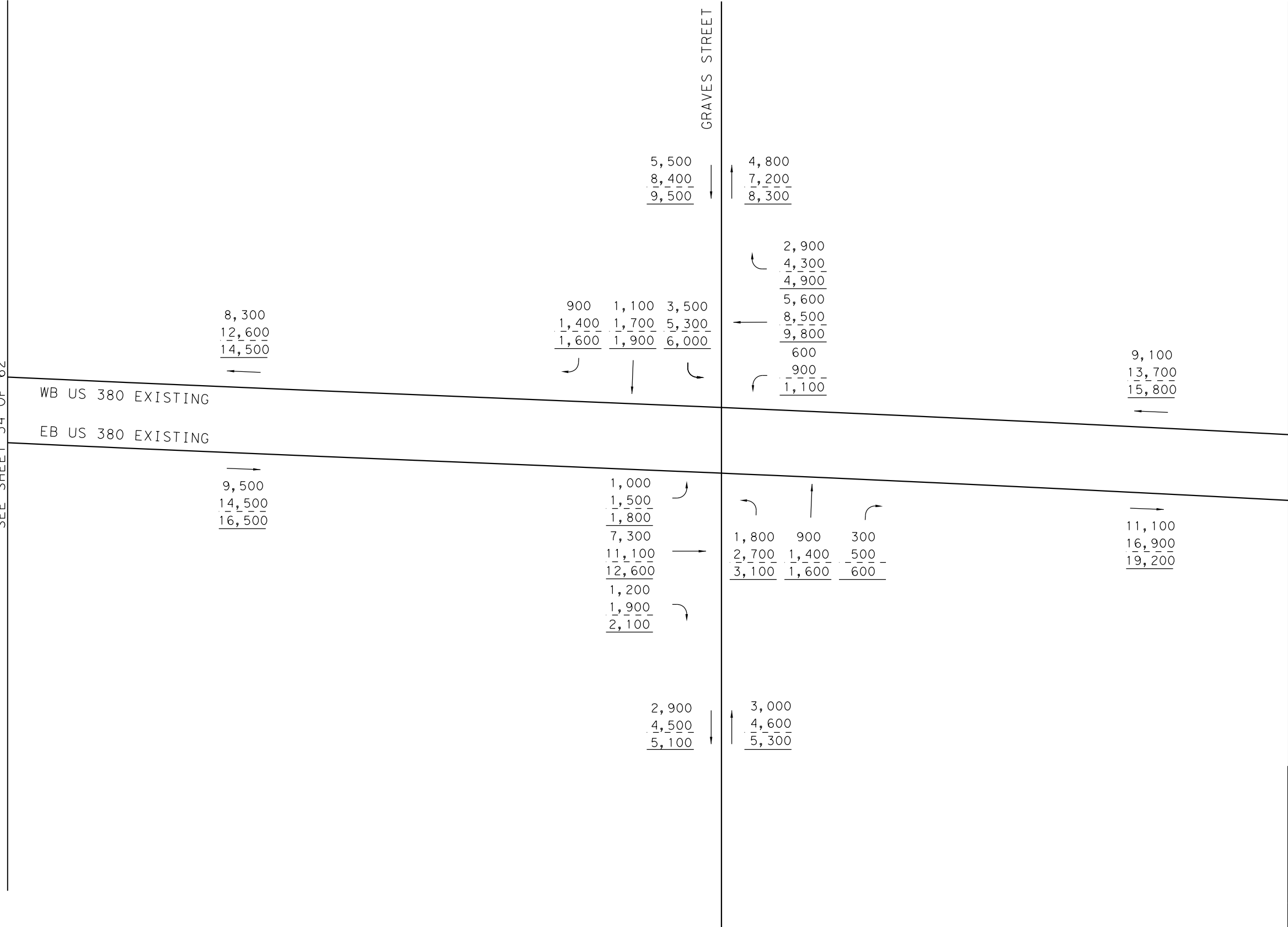
- XXXX- 2030 AVERAGE DAILY TRAFFIC VOLUMES
- XXXX- 2050 AVERAGE DAILY TRAFFIC VOLUMES
- XXXX- 2060 AVERAGE DAILY TRAFFIC VOLUMES

DATE: 7/13/2021
FILE: US380_BROWN_TRF_54.dgn



SEE SHEET 54 OF 62

SEE SHEET 56 OF 62



LEGEND

- XXXX- 2030 AVERAGE DAILY TRAFFIC VOLUMES
- XXXX- 2050 AVERAGE DAILY TRAFFIC VOLUMES
- XXXX- 2060 AVERAGE DAILY TRAFFIC VOLUMES

NOT TO SCALE

NOT INTENDED FOR CONSTRUCTION,
BIDDING OR PERMIT PURPOSES
DHURVA LAHON, P.E.
SERIAL NUMBER 102185

EXISTING US 380 AND
GRAVES ST
AVERAGE DAILY TRAFFIC





SEE SHEET 55 OF 62

SEE SHEET 57 OF 62

WB US 380 EXISTING

EB US 380 EXISTING

WADDILL STREET

9,100
13,700
15,800

200 200 600
300 300 900
400 400 1,100

1,000 600
1,500 900
1,900 1,200

200
300
400
8,200
12,300
14,100
900
1,400
1,600

9,300
14,000
16,100

11,100
16,900
19,200

200
300
400
9,800
14,900
16,900
1,100
1,700
1,900

700 200 1,300
1,100 300 2,000
1,300 400 2,300

11,700
17,800
20,300

2,200 2,200
3,400 3,400
3,900 4,000

NOT TO SCALE

NOT INTENDED FOR CONSTRUCTION,
BIDDING OR PERMIT PURPOSES
DHURVA LAHON, P.E.
SERIAL NUMBER 102185

EXISTING US 380 AND
WADDILL ST
AVERAGE DAILY TRAFFIC

Kimley»Horn
F-928

0135-02-065,
ETC. SHEET 56 OF 62

LEGEND

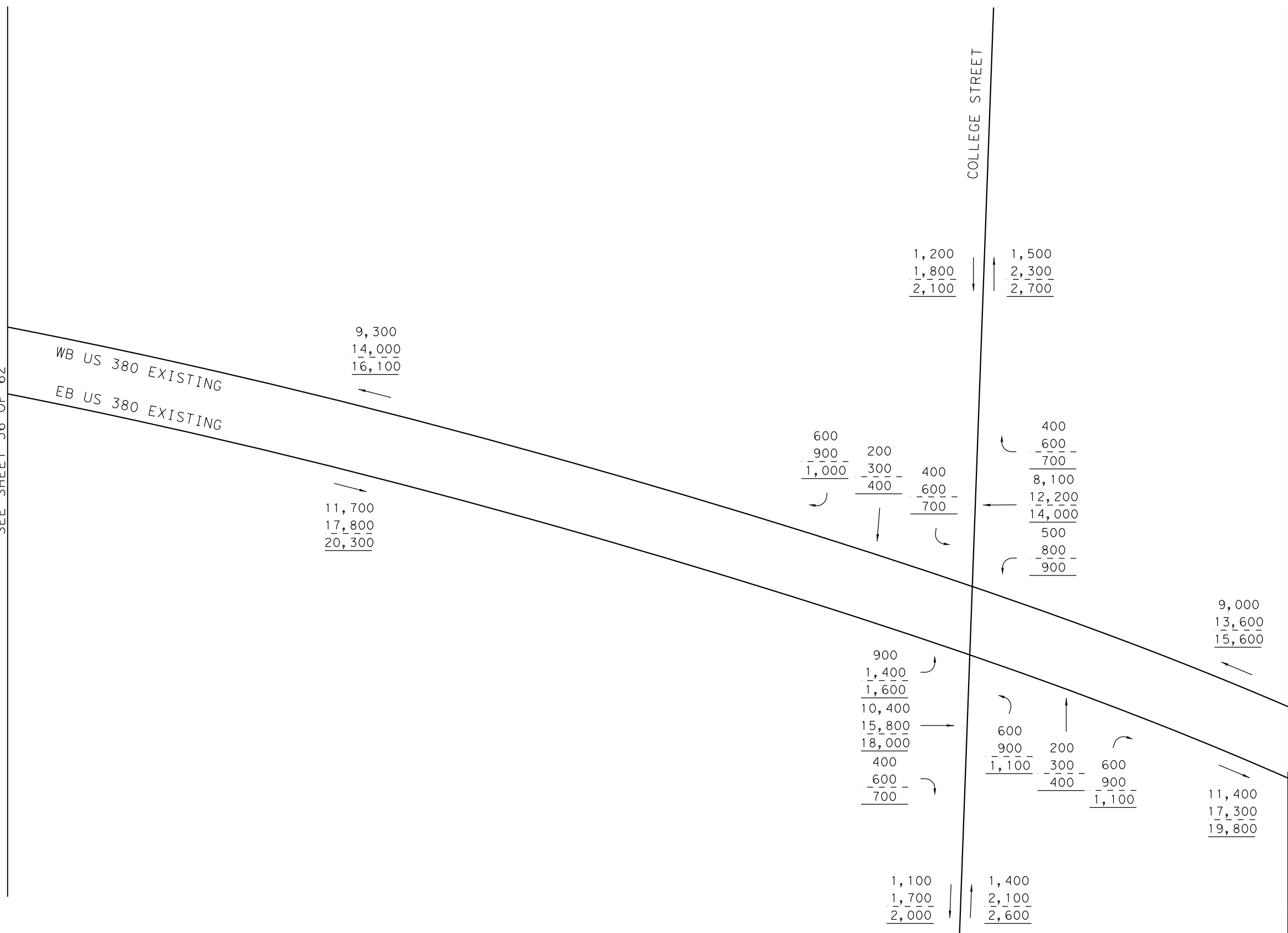
- XXXX- 2030 AVERAGE DAILY TRAFFIC VOLUMES
- XXXX- 2050 AVERAGE DAILY TRAFFIC VOLUMES
- XXXX- 2060 AVERAGE DAILY TRAFFIC VOLUMES

DATE: 7/13/2021
FILE: US380_BROWN_TRF_56.dgn



SEE SHEET 56 OF 62

SEE SHEET 58 OF 62



LEGEND

- XXXX- 2030 AVERAGE DAILY TRAFFIC VOLUMES
- XXXX- 2050 AVERAGE DAILY TRAFFIC VOLUMES
- XXXX- 2060 AVERAGE DAILY TRAFFIC VOLUMES

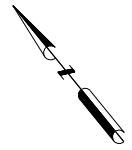
NOT TO SCALE

NOT INTENDED FOR CONSTRUCTION,
 BIDDING OR PERMIT PURPOSES
 DHRUVA LAHON, P.E.
 SERIAL NUMBER 102185

EXISTING US 380 AND COLLEGE ST AVERAGE DAILY TRAFFIC

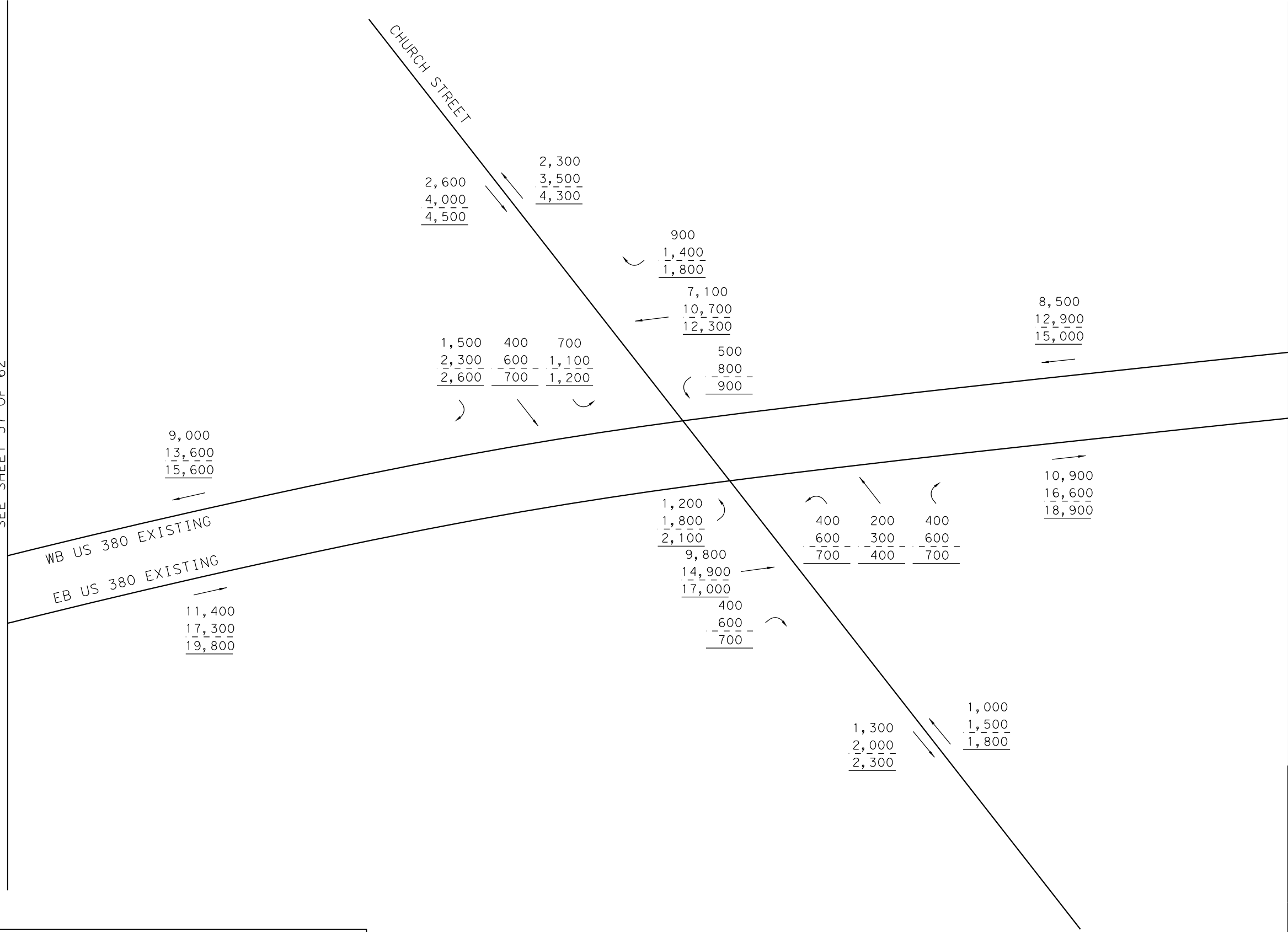


DATE: 7/13/2021
 FILE: US380_BROWN_TRF_57.dgn



SEE SHEET 57 OF 62

SEE SHEET 59 OF 62



NOT TO SCALE

NOT INTENDED FOR CONSTRUCTION,
 BIDDING OR PERMIT PURPOSES
 DHRUVA LAHON, P.E.
 SERIAL NUMBER 102185

EXISTING US 380 AND
 CHURCH ST
 AVERAGE DAILY TRAFFIC

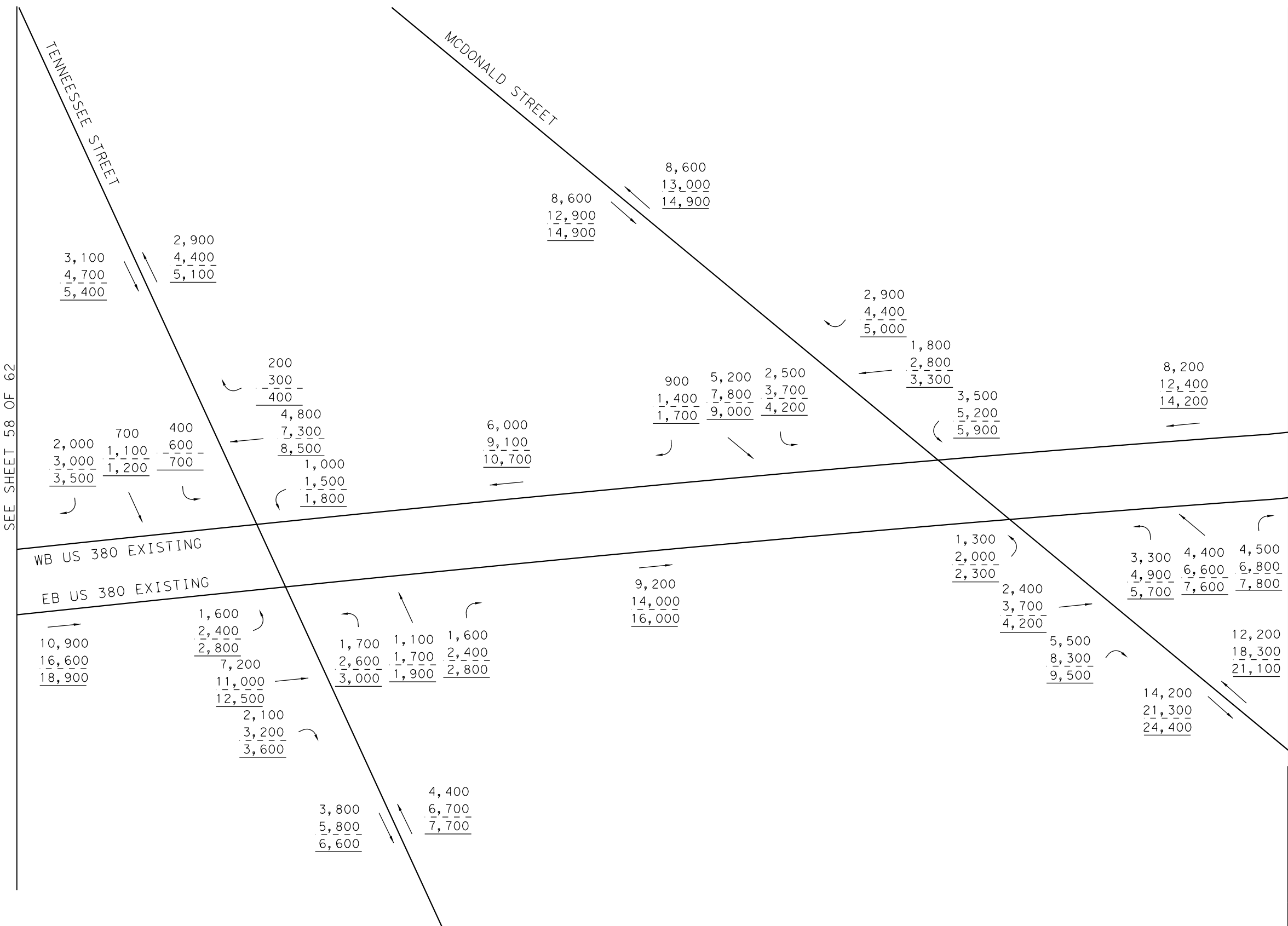
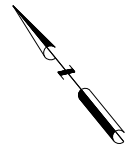


0135-02-065,
 ETC. SHEET 58 OF 62

LEGEND

- XXXX- 2030 AVERAGE DAILY TRAFFIC VOLUMES
- XXXX- 2050 AVERAGE DAILY TRAFFIC VOLUMES
- XXXX- 2060 AVERAGE DAILY TRAFFIC VOLUMES

DATE: 7/13/2021
 FILE: US380_BROWN_TRF_58.dgn



SEE SHEET 58 OF 62

SEE SHEET 60 OF 62

WB US 380 EXISTING
 EB US 380 EXISTING

NOT TO SCALE

NOT INTENDED FOR CONSTRUCTION,
 BIDDING OR PERMIT PURPOSES
 DHRUVA LAHON, P.E.
 SERIAL NUMBER 102185

EXISTING US 380 AND
 MCDONALD ST/ SH 5
 AVERAGE DAILY TRAFFIC

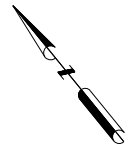
Kimley»Horn
F-928

0135-02-065,
 ETC. SHEET 59 OF 62

LEGEND

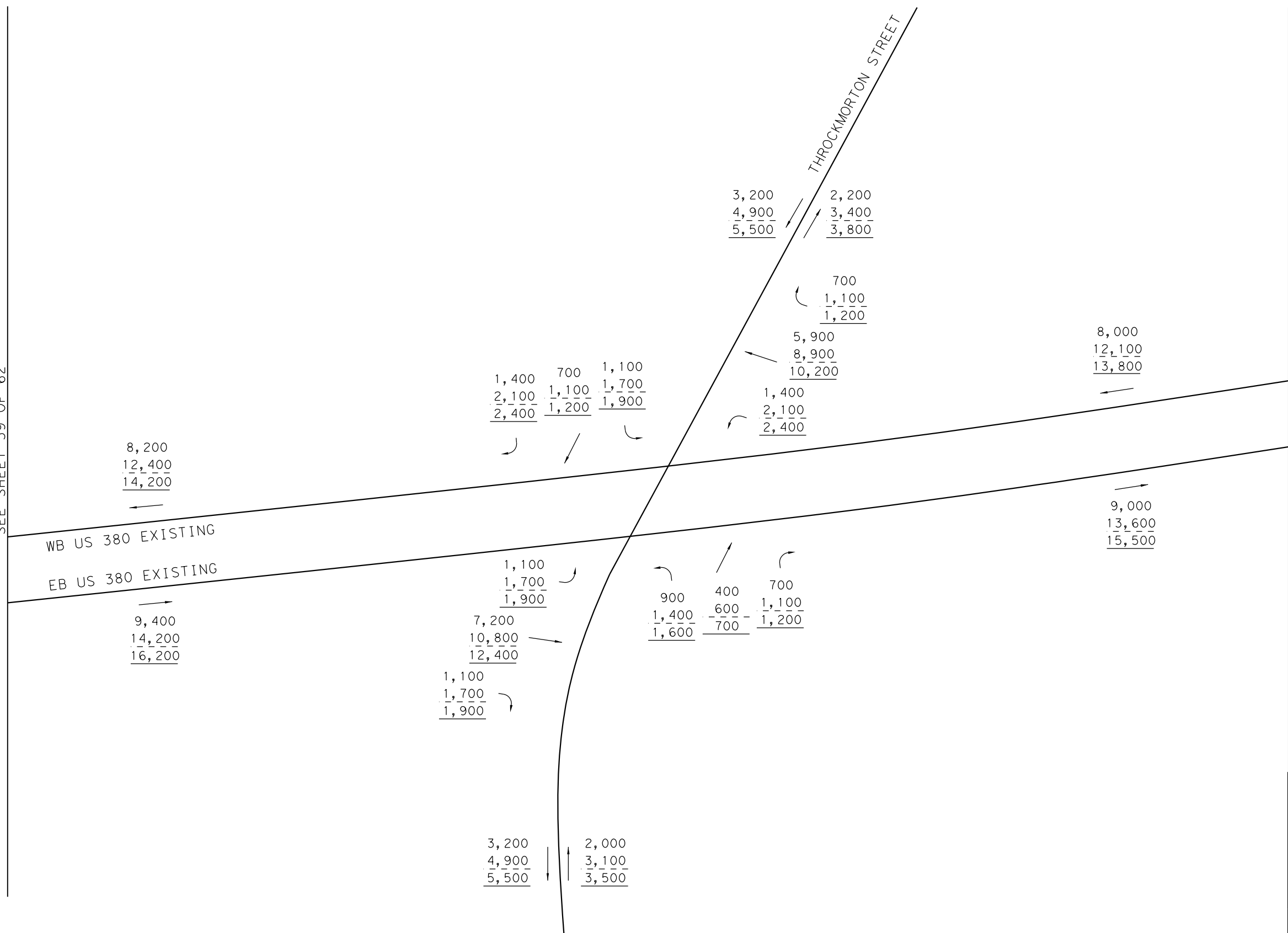
- XXXX- 2030 AVERAGE DAILY TRAFFIC VOLUMES
- XXXX- 2050 AVERAGE DAILY TRAFFIC VOLUMES
- XXXX- 2060 AVERAGE DAILY TRAFFIC VOLUMES

DATE: 7/13/2021
 FILE: US380_BROWN_TRF_59.dgn



SEE SHEET 59 OF 62

SEE SHEET 61 OF 62



NOT TO SCALE

NOT INTENDED FOR CONSTRUCTION,
 BIDDING OR PERMIT PURPOSES
 DHRUVA LAHON, P.E.
 SERIAL NUMBER 102185

EXISTING US 380 AND
 THROCKMORTON ST
 AVERAGE DAILY TRAFFIC

Kimley»Horn
F-928

0135-02-065,
 ETC. SHEET 60 OF 62

LEGEND

- XXXX- 2030 AVERAGE DAILY TRAFFIC VOLUMES
- XXXX- 2050 AVERAGE DAILY TRAFFIC VOLUMES
- XXXX- 2060 AVERAGE DAILY TRAFFIC VOLUMES

DATE: 7/13/2021
 FILE: US380_BROWN_TRF_60.dgn



SEE SHEET 60 OF 62

SEE SHEET 62 OF 62

8,000
12,100
 13,800

WB US 380 EXISTING

9,000
13,600
 15,500

EB US 380 EXISTING

5,300
7,900
 9,000

8,200
12,400
 14,200

5,300
8,000
 9,100

3,700
5,600
 6,400

2,700
4,200
 4,800

8,000
12,000
 13,700

13,500
20,300
 23,200

13,300
20,000
 22,800

11,900
18,000
 20,600

10,700
16,200
 18,500

AIRPORT DRIVE

NOT TO SCALE

NOT INTENDED FOR CONSTRUCTION,
 BIDDING OR PERMIT PURPOSES
 DHRUVA LAHON, P.E.
 SERIAL NUMBER 102185

EXISTING US 380 AND
 AIRPORT DR
 AVERAGE DAILY TRAFFIC

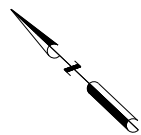
Kimley»Horn
F-928

0135-02-065,
 ETC. SHEET 61 OF 62

LEGEND

- XXXX- 2030 AVERAGE DAILY TRAFFIC VOLUMES
- XXXX- 2050 AVERAGE DAILY TRAFFIC VOLUMES
- XXXX- 2060 AVERAGE DAILY TRAFFIC VOLUMES

DATE: 7/13/2021
 FILE: US380_BROWN_TRF_61.dgn



SEE SHEET 41 OF 62

13,500	↙	↘	13,300
<u>20,300</u>			<u>20,000</u>
<u>23,200</u>			<u>22,800</u>

SEE SHEET 61 OF 62

13,500
<u>20,300</u>
<u>23,200</u>

↙
WB US 380 EXISTING
↘
EB US 380 EXISTING

13,300
<u>20,000</u>
<u>22,800</u>

NOT TO SCALE

NOT INTENDED FOR CONSTRUCTION,
BIDDING OR PERMIT PURPOSES
DHURVA LAHON, P.E.
SERIAL NUMBER 102185

EXISTING US 380 AND
NEW HOPE RD/ FM 1827
AVERAGE DAILY TRAFFIC

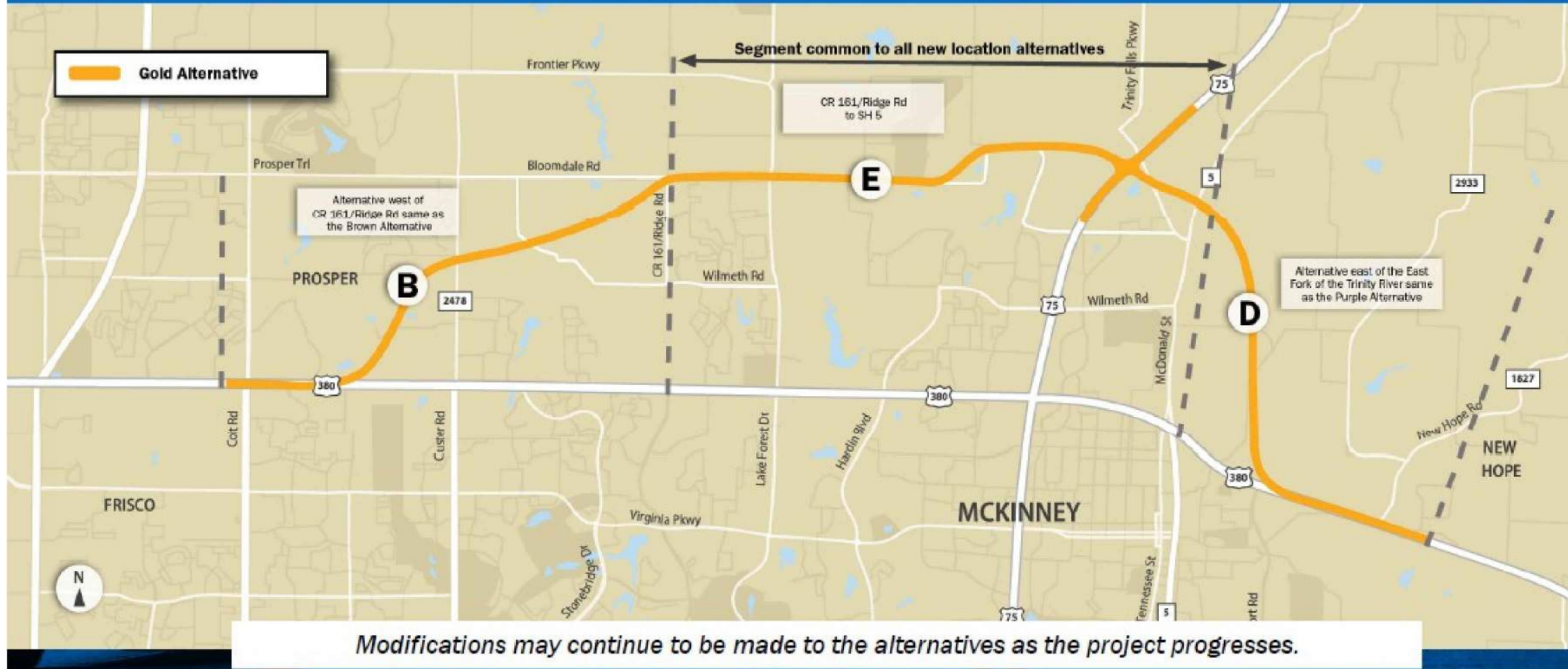
Kimley»Horn
F-928

0135-02-065, SHEET 62 OF 62
ETC.

LEGEND

XXXX-	2030	AVERAGE	DAILY	TRAFFIC	VOLUMES
-XXXX-	2050	AVERAGE	DAILY	TRAFFIC	VOLUMES
<u>XXXX-</u>	2060	AVERAGE	DAILY	TRAFFIC	VOLUMES

Gold Build Alternative – New Location



US 380 EIS – Coit Road to FM 1827

CSJs: 0135-02-065 and 0135-03-053

January 21, 2021

29

NOT TO SCALE

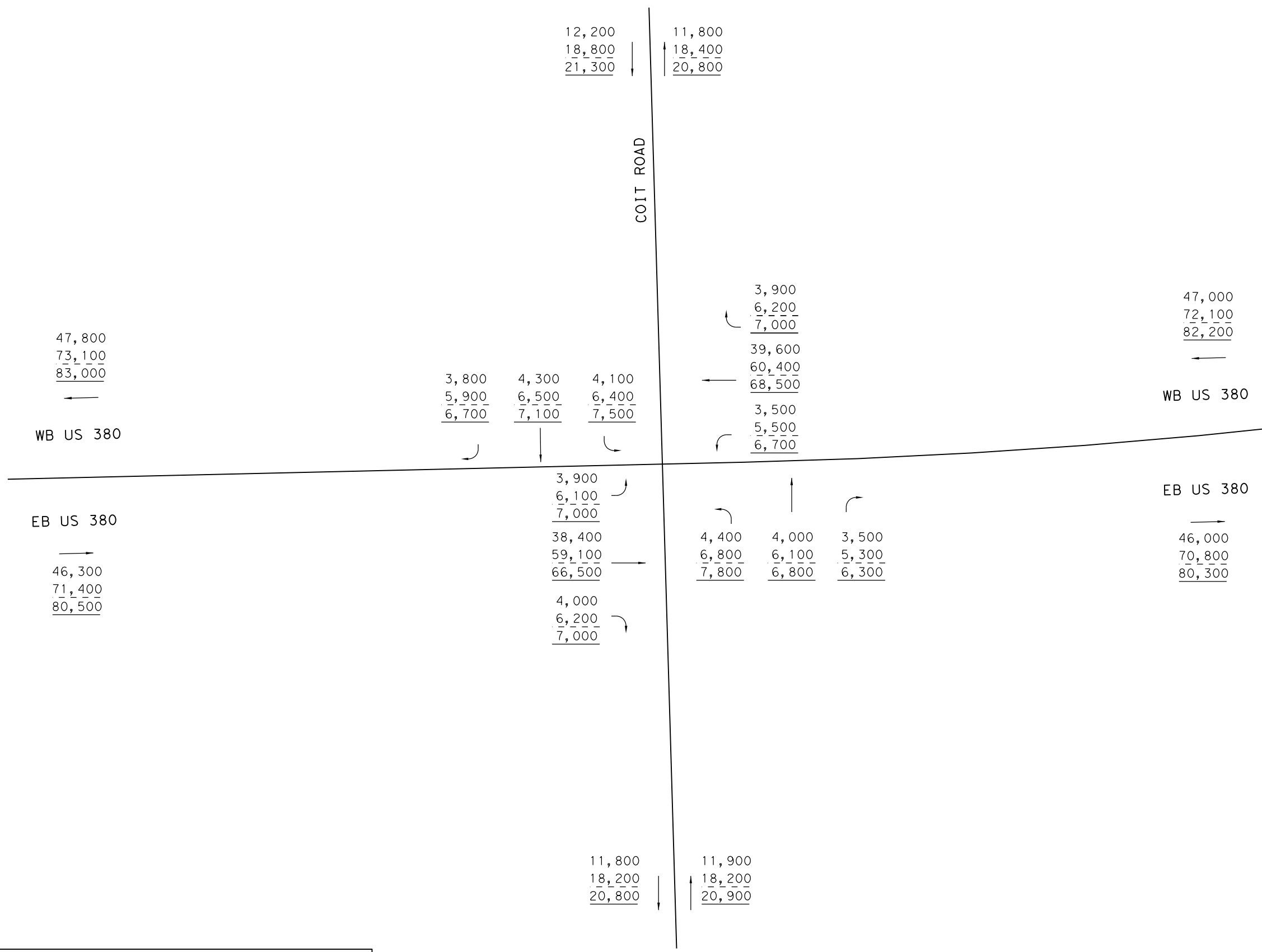
NOT INTENDED FOR CONSTRUCTION,
BIDDING OR PERMIT PURPOSES
DHURVA LAHON, P.E.
SERIAL NUMBER 102185

US 380 GOLD ALT
KEYMAP

Kimley»Horn
F-928

0135-02-065,
ETC.

SHEET 1 OF 1



SEE SHEET 2 OF 61

NOT TO SCALE

NOT INTENDED FOR CONSTRUCTION,
 BIDDING OR PERMIT PURPOSES
 DHRUVA LAHON, P.E.
 SERIAL NUMBER 102185

US 380 GOLD ALT AND
 COIT RD
 AVERAGE DAILY TRAFFIC
 GOLD ALT BUILD VOLUMES

Kimley»Horn
F-928

0135-02-065,
 ETC.

SHEET 1 OF 61

LEGEND

- XXXX- 2030 AVERAGE DAILY TRAFFIC VOLUMES
- XXXX- 2050 AVERAGE DAILY TRAFFIC VOLUMES
- XXXX- 2060 AVERAGE DAILY TRAFFIC VOLUMES

DATE: 7/13/2021
 FILE: US380_GOLD_TRF_01.dgn



SEE SHEET 1 OF 61

SEE SHEET 3 OF 61

47,000
72,100
82,200

←
WB US 380

EB US 380

→
46,000
70,800
80,300

ENTRANCE FROM INDEPENDENCE PARKWAY

47,000
72,100
82,200

EXIT TO INDEPENDENCE PARKWAY

46,000
70,800
80,300

WB US 380

47,000
72,100
82,200

EB US 380

→
46,000
70,800
80,300

NOT TO SCALE

NOT INTENDED FOR CONSTRUCTION,
BIDDING OR PERMIT PURPOSES
DHURVA LAHON, P.E.
SERIAL NUMBER 102185

US 380 GOLD ALT AND
RAMPS
AVERAGE DAILY TRAFFIC
GOLD ALT BUILD VOLUMES

Kimley»Horn
F-928

0135-02-065,
ETC.

SHEET 2 OF 61

LEGEND

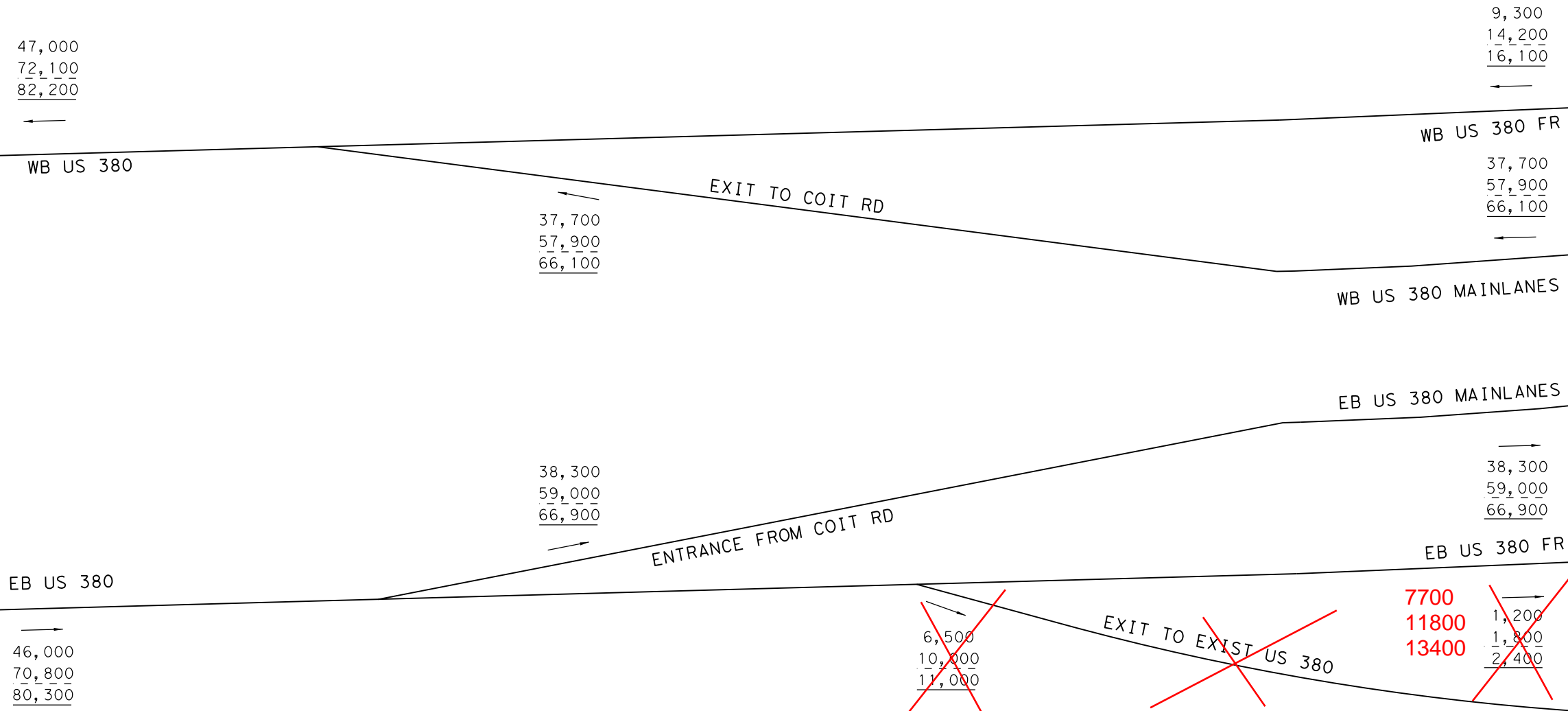
- XXXX- 2030 AVERAGE DAILY TRAFFIC VOLUMES
- XXXX- 2050 AVERAGE DAILY TRAFFIC VOLUMES
- XXXX- 2060 AVERAGE DAILY TRAFFIC VOLUMES

DATE: 7/13/2021
FILE: US380_GOLD_TRF_02.dgn



SEE SHEET 2 OF 61

SEE SHEET 4 OF 61



NOT TO SCALE

NOT INTENDED FOR CONSTRUCTION,
 BIDDING OR PERMIT PURPOSES
 DHRUVA LAHON, P.E.
 SERIAL NUMBER 102185

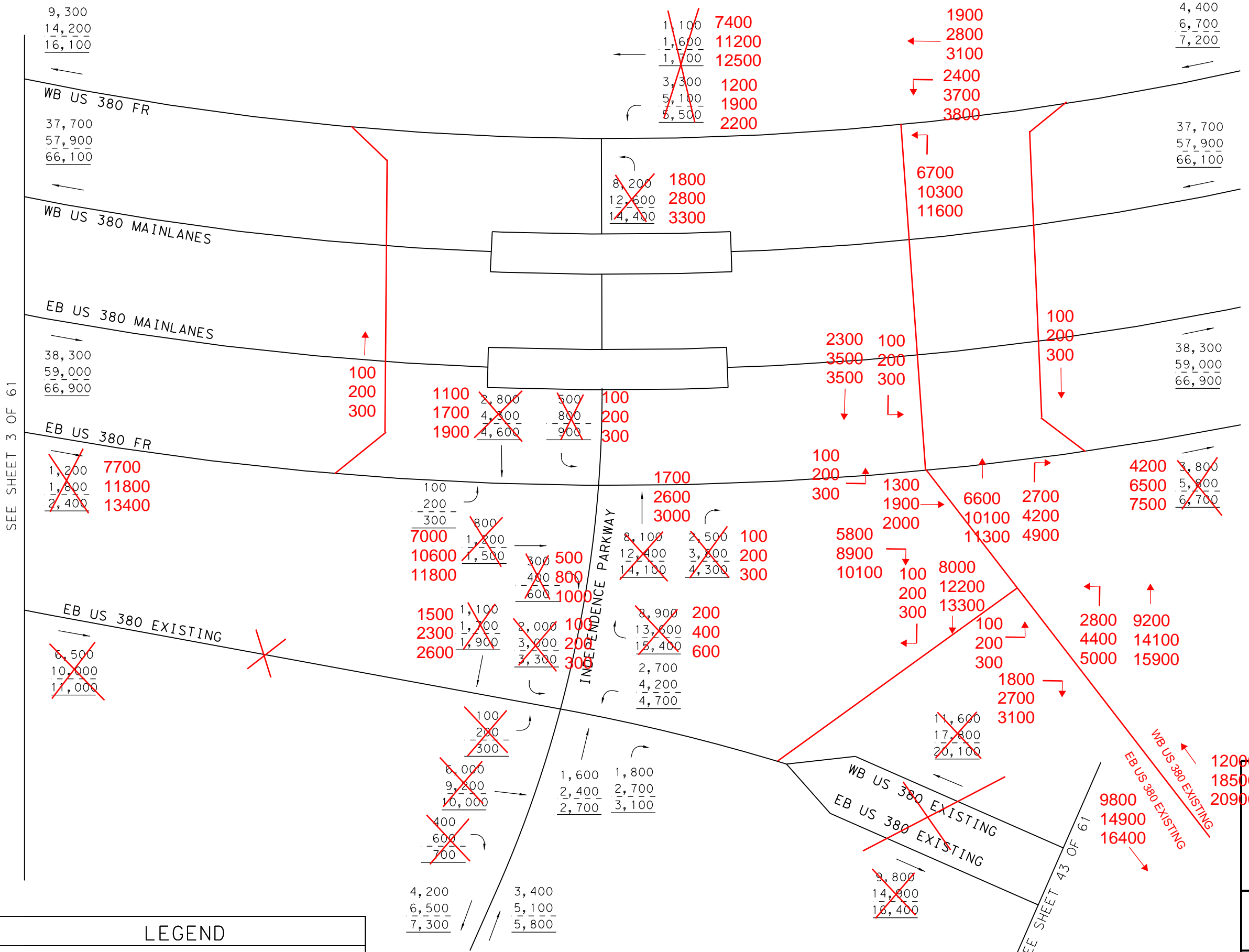
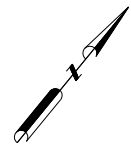
US 380 GOLD ALT AND
 RAMPS
 AVERAGE DAILY TRAFFIC
 GOLD ALT BUILD VOLUMES



LEGEND

- XXXX- 2030 AVERAGE DAILY TRAFFIC VOLUMES
- XXXX- 2050 AVERAGE DAILY TRAFFIC VOLUMES
- XXXX- 2060 AVERAGE DAILY TRAFFIC VOLUMES

DATE: 7/13/2021
 FILE: US380_GOLD_TRF_03.dgn



SEE SHEET 3 OF 61

SEE SHEET 5 OF 61

SEE SHEET 43 OF 61

NOT TO SCALE

NOT INTENDED FOR CONSTRUCTION,
 BIDDING OR PERMIT PURPOSES
 DHRUVA LAHON, P.E.
 SERIAL NUMBER 102185

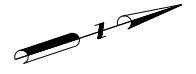
US 380 GOLD ALT AND
 INDEPENDENCE PKWY
 AVERAGE DAILY TRAFFIC
 GOLD ALT BUILD VOLUMES

Kimley»Horn
 F-928

0135-02-065,
 ETC. SHEET 4 OF 61

LEGEND	
XXXX-	2030 AVERAGE DAILY TRAFFIC VOLUMES
-XXXX-	2050 AVERAGE DAILY TRAFFIC VOLUMES
XXXX-	2060 AVERAGE DAILY TRAFFIC VOLUMES

DATE: 7/13/2021
 FILE: US380_GOLD_TRF_04.dgn



SEE SHEET 4 OF 61

4,400
6,700
7,200

WB US 380 FR

37,700
57,900
66,100

ENTRANCE FROM N CUSTER RD (FM 4278)

6,700
10,400
11,800

11,100
17,100
19,000

WB US 380 MAINLANES

31,000
47,500
54,300

EB US 380 MAINLANES

38,300
59,000
66,900

7,000
10,800
12,200

EXIT TO N CUSTER RD (FM 2478)

EB US 380 FR

~~3,800~~ 4200
~~5,800~~ 6500
~~6,700~~ 7500

31,300
48,200
54,700

11200
17300
19700

~~10,800~~
~~16,600~~
~~18,900~~

SEE SHEET 6 OF 61

NOT TO SCALE

NOT INTENDED FOR CONSTRUCTION,
BIDDING OR PERMIT PURPOSES
DHURVA LAHON, P.E.
SERIAL NUMBER 102185

US 380 GOLD ALT AND
RAMPS
AVERAGE DAILY TRAFFIC
GOLD ALT BUILD VOLUMES

Kimley»Horn
F-928

0135-02-065,
ETC.

SHEET 5 OF 61

LEGEND

- XXXX- 2030 AVERAGE DAILY TRAFFIC VOLUMES
- XXXX- 2050 AVERAGE DAILY TRAFFIC VOLUMES
- XXXX- 2060 AVERAGE DAILY TRAFFIC VOLUMES

DATE: 7/13/2021
FILE: US380_GOLD_TRF_05.dgn



SEE SHEET 5 OF 61

SEE SHEET 7 OF 61

11,100
17,100
19,000

WB US 380 FR

31,000
47,500
54,300

WB US 380 MAINLANES

EB US 380 MAINLANES

31,300
48,200
54,700

EB US 380 FR

~~10,800~~ 11200
~~16,600~~ 17300
~~18,900~~ 19700

4,200
6,500
7,200

ENTRANCE FROM INDEPENDENCE PARKWAY

4,200
6,500
7,300

EXIT TO INDEPENDENCE PARKWAY

6,900
10,600
11,700

35,200
54,000
61,600

35,500
54,700
61,900

7000
10800
12500

~~6,600~~
~~10,100~~
~~11,700~~

NOT TO SCALE

NOT INTENDED FOR CONSTRUCTION,
BIDDING OR PERMIT PURPOSES
DHURVA LAHON, P.E.
SERIAL NUMBER 102185

US 380 GOLD ALT AND
RAMPS
AVERAGE DAILY TRAFFIC
GOLD ALT BUILD VOLUMES

Kimley»Horn
F-928

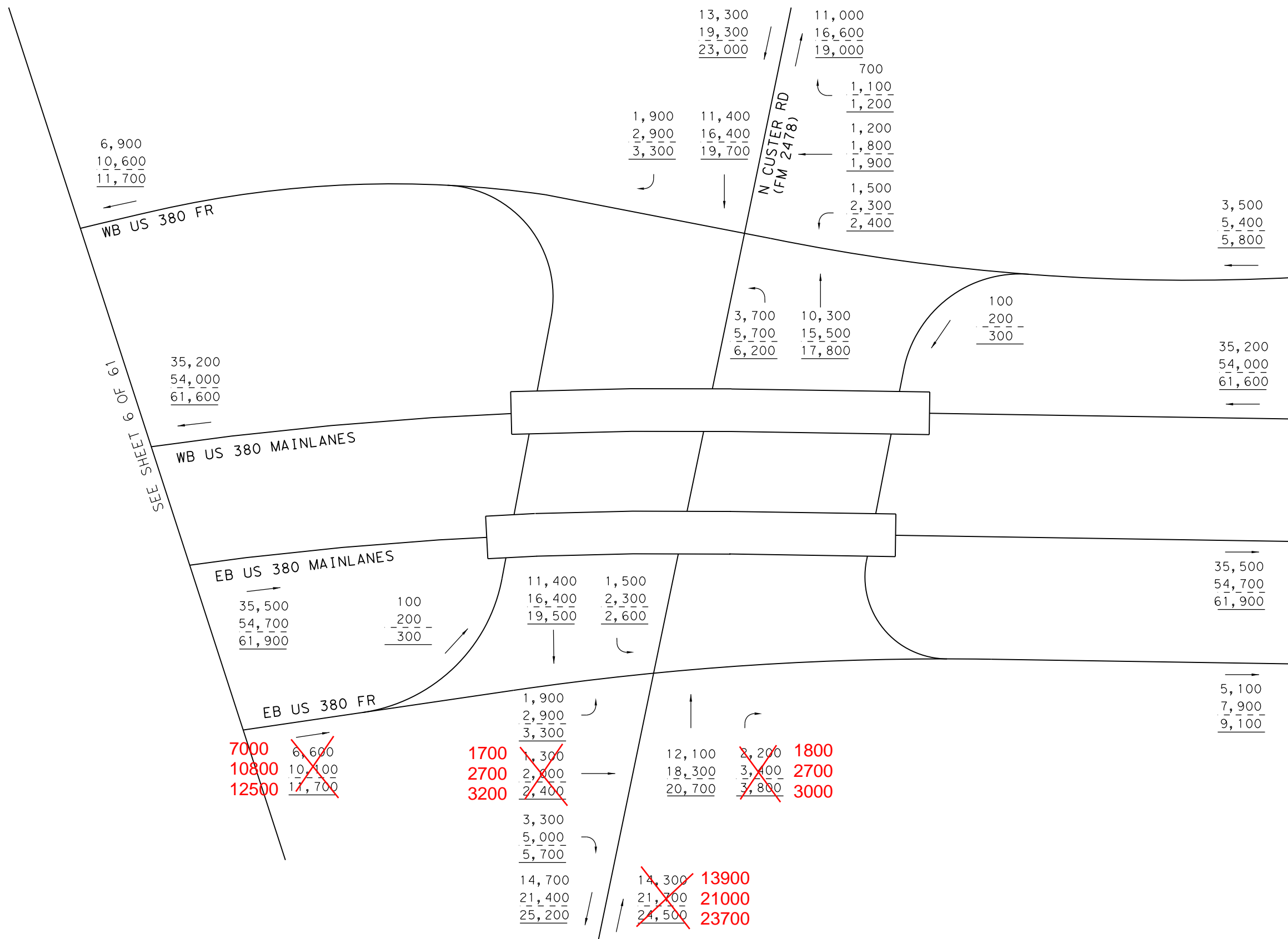
0135-02-065,
ETC.

SHEET 6 OF 61

LEGEND

- XXXX- 2030 AVERAGE DAILY TRAFFIC VOLUMES
- XXXX- 2050 AVERAGE DAILY TRAFFIC VOLUMES
- XXXX- 2060 AVERAGE DAILY TRAFFIC VOLUMES

DATE: 7/13/2021
FILE: US380_GOLD_TRF_06.dgn



6,900
10,600
11,700

WB US 380 FR

35,200
54,000
61,600

WB US 380 MAINLANES

EB US 380 MAINLANES

35,500
54,700
61,900

EB US 380 FR

~~6,600~~
~~10,100~~
~~11,700~~

7000
10800
12500

~~1,300~~
~~2,000~~
~~2,400~~

1700
2700
3200

3,300
5,000
5,700

14,700
21,400
25,200

13,300
19,300
23,000

1,900
2,900
3,300

11,400
16,400
19,700

N CUSTER RD
(FM 2478)

11,000
16,600
19,000

700
1,100
1,200

1,200
1,800
1,900

1,500
2,300
2,400

3,700
5,700
6,200

10,300
15,500
17,800

100
200
300

3,500
5,400
5,800

35,200
54,000
61,600

35,500
54,700
61,900

5,100
7,900
9,100

~~2,200~~
~~3,400~~
~~3,800~~

12,100
18,300
20,700

1800
2700
3000

~~14,300~~
~~21,700~~
~~24,500~~

13900
21000
23700

SEE SHEET 6 OF 61

SEE SHEET 8 OF 61

NOT TO SCALE

NOT INTENDED FOR CONSTRUCTION,
BIDDING OR PERMIT PURPOSES
DHURVA LAHON, P.E.
SERIAL NUMBER 102185

US 380 GOLD ALT AND
FM 2478
AVERAGE DAILY TRAFFIC
GOLD ALT BUILD VOLUMES

Kimley»Horn
F-928

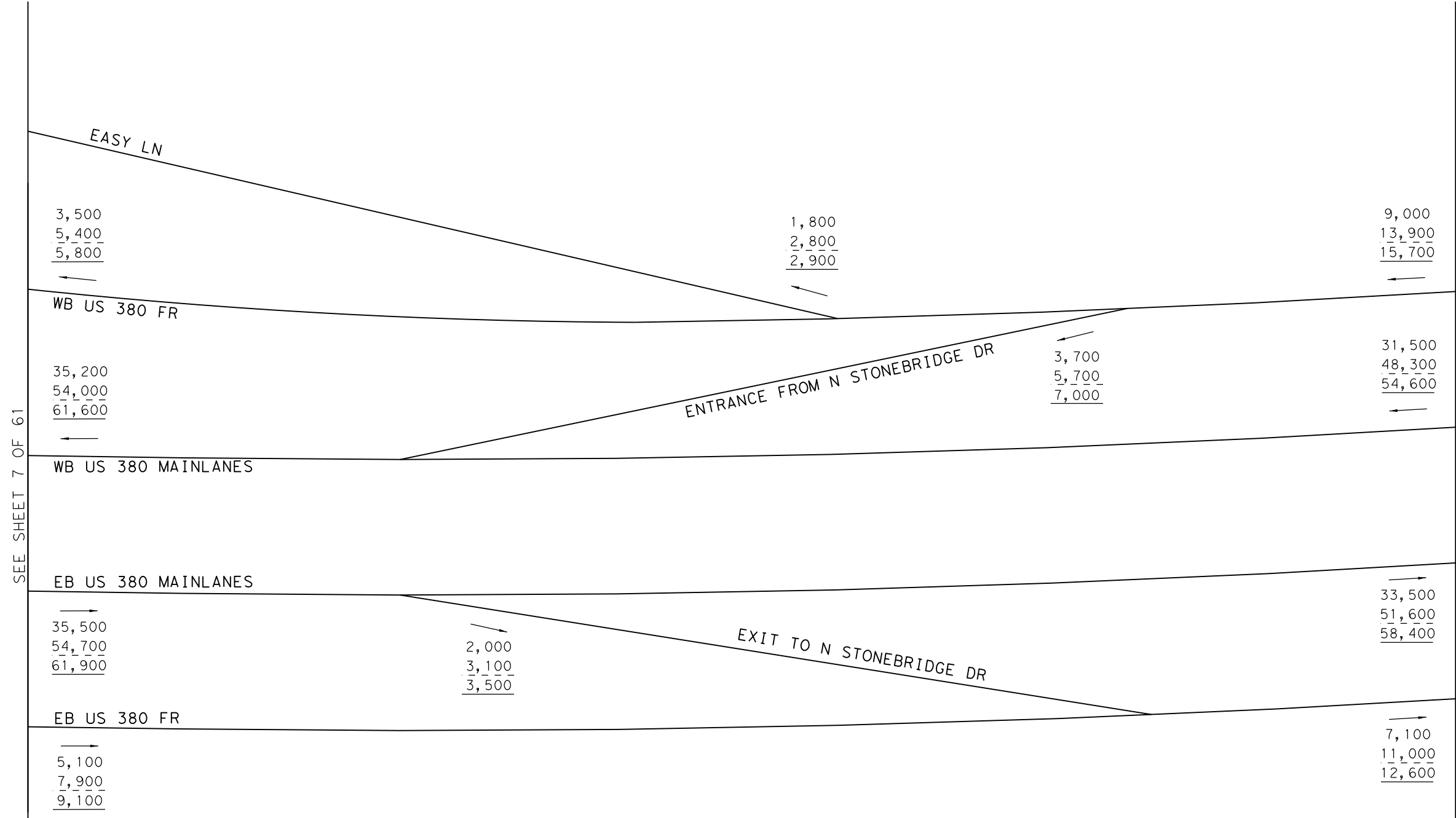
0135-02-065,
ETC.

SHEET 7 OF 61

LEGEND

- XXXX- 2030 AVERAGE DAILY TRAFFIC VOLUMES
- XXXX- 2050 AVERAGE DAILY TRAFFIC VOLUMES
- XXXX- 2060 AVERAGE DAILY TRAFFIC VOLUMES

DATE: 7/13/2021
FILE: US380_GOLD_TRF_07.dgn



SEE SHEET 7 OF 61

SEE SHEET 9 OF 61

NOT TO SCALE

NOT INTENDED FOR CONSTRUCTION,
 BIDDING OR PERMIT PURPOSES
 DHRUVA LAHON, P.E.
 SERIAL NUMBER 102185

US 380 GOLD ALT AND
 RAMPS
 AVERAGE DAILY TRAFFIC
 GOLD ALT BUILD VOLUMES

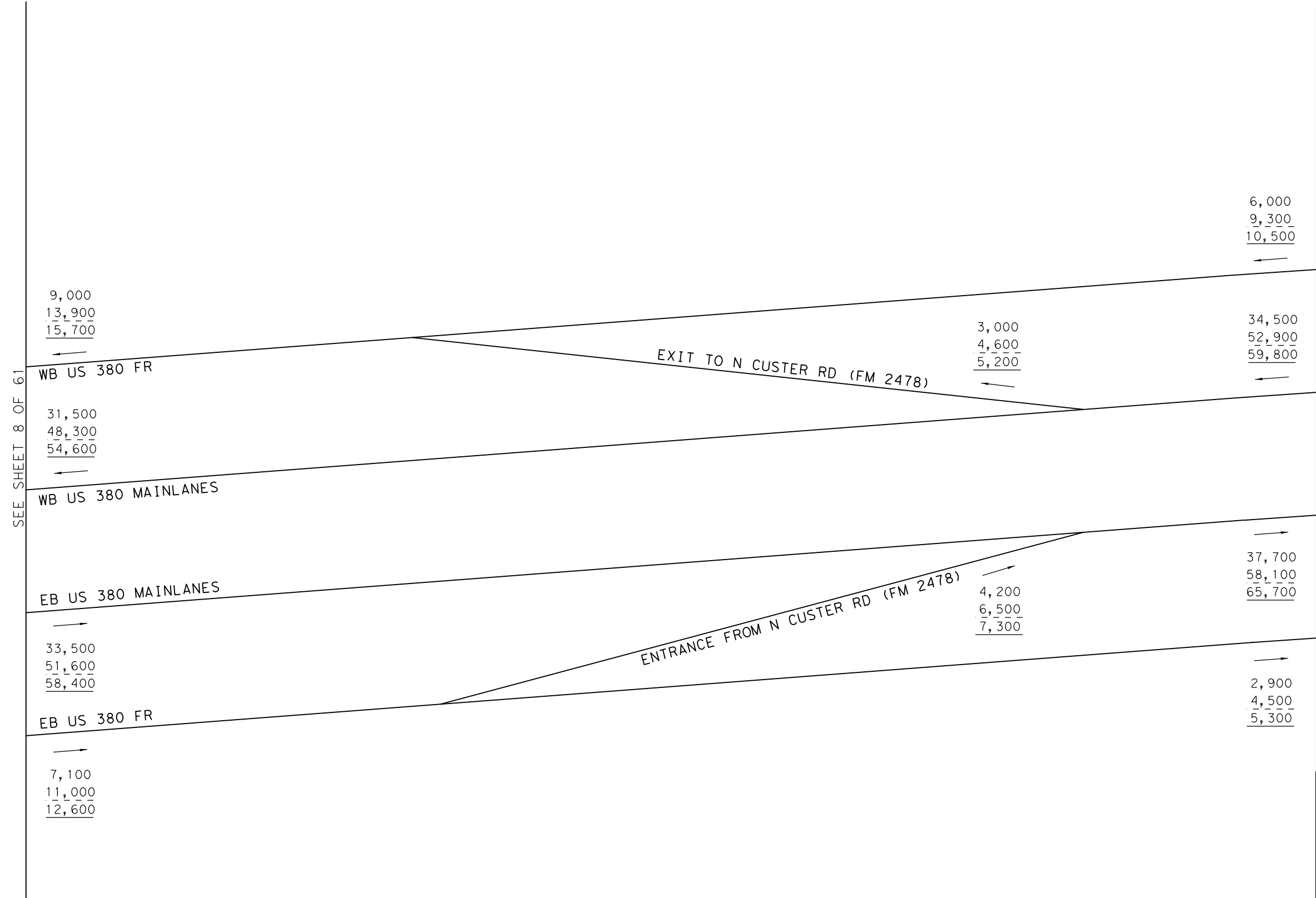
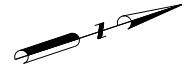


0135-02-065,
ETC.

SHEET 8 OF 61

LEGEND

- XXXX- 2030 AVERAGE DAILY TRAFFIC VOLUMES
- XXXX- 2050 AVERAGE DAILY TRAFFIC VOLUMES
- XXXX- 2060 AVERAGE DAILY TRAFFIC VOLUMES



SEE SHEET 8 OF 61

SEE SHEET 10 OF 61

NOT TO SCALE

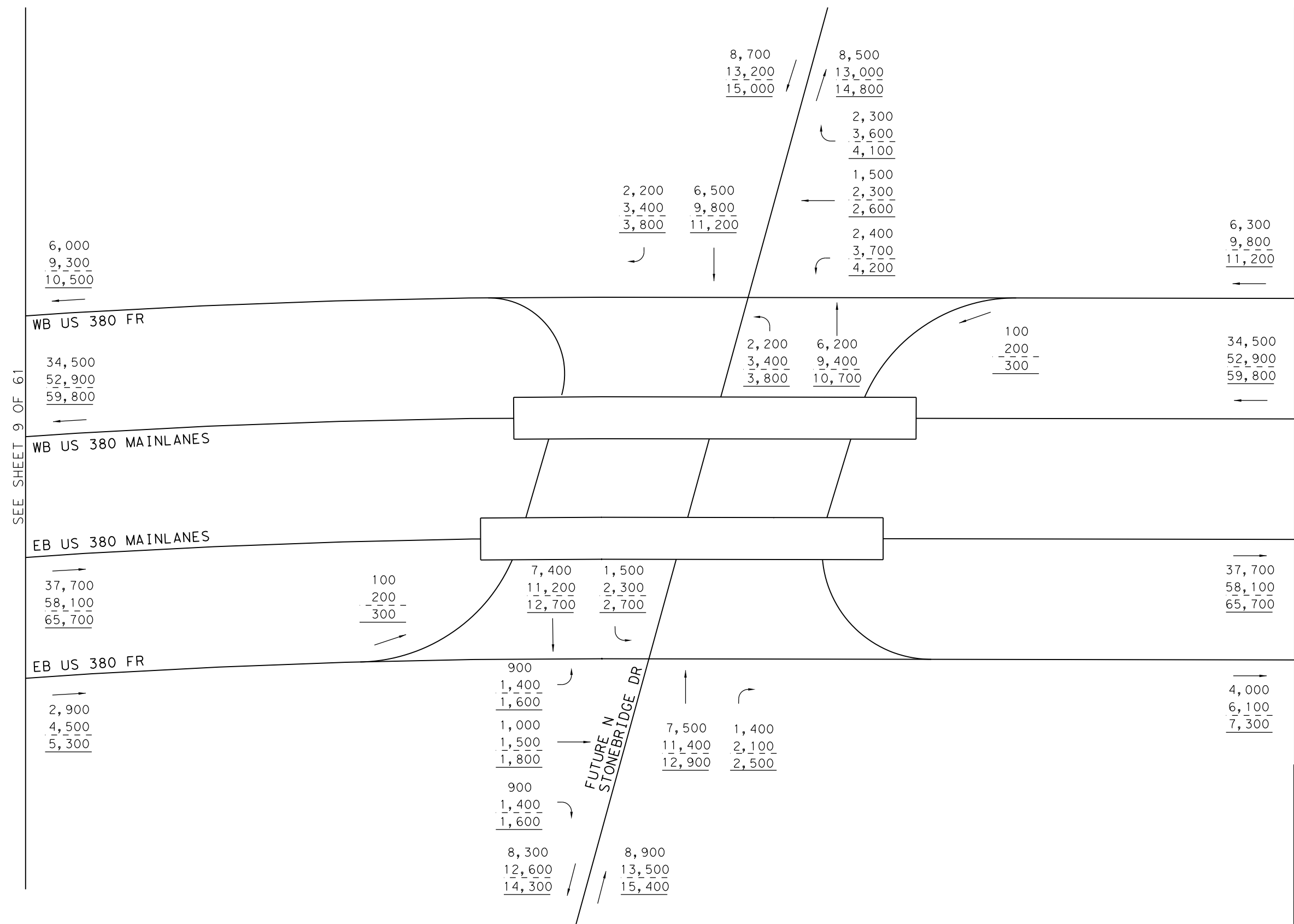
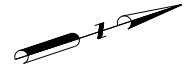
NOT INTENDED FOR CONSTRUCTION,
 BIDDING OR PERMIT PURPOSES
 DHRUVA LAHON, P.E.
 SERIAL NUMBER 102185

US 380 GOLD ALT AND
 RAMPS
 AVERAGE DAILY TRAFFIC
 GOLD ALT BUILD VOLUMES



LEGEND

- XXXX- 2030 AVERAGE DAILY TRAFFIC VOLUMES
- XXXX- 2050 AVERAGE DAILY TRAFFIC VOLUMES
- XXXX- 2060 AVERAGE DAILY TRAFFIC VOLUMES



SEE SHEET 9 OF 61

SEE SHEET 11 OF 61

NOT TO SCALE

NOT INTENDED FOR CONSTRUCTION,
 BIDDING OR PERMIT PURPOSES
 DHRUVA LAHON, P.E.
 SERIAL NUMBER 102185

US 380 GOLD ALT AND
 CR 124
 AVERAGE DAILY TRAFFIC
 GOLD ALT BUILD VOLUMES



0135-02-065,
 ETC. SHEET 10 OF 61

LEGEND

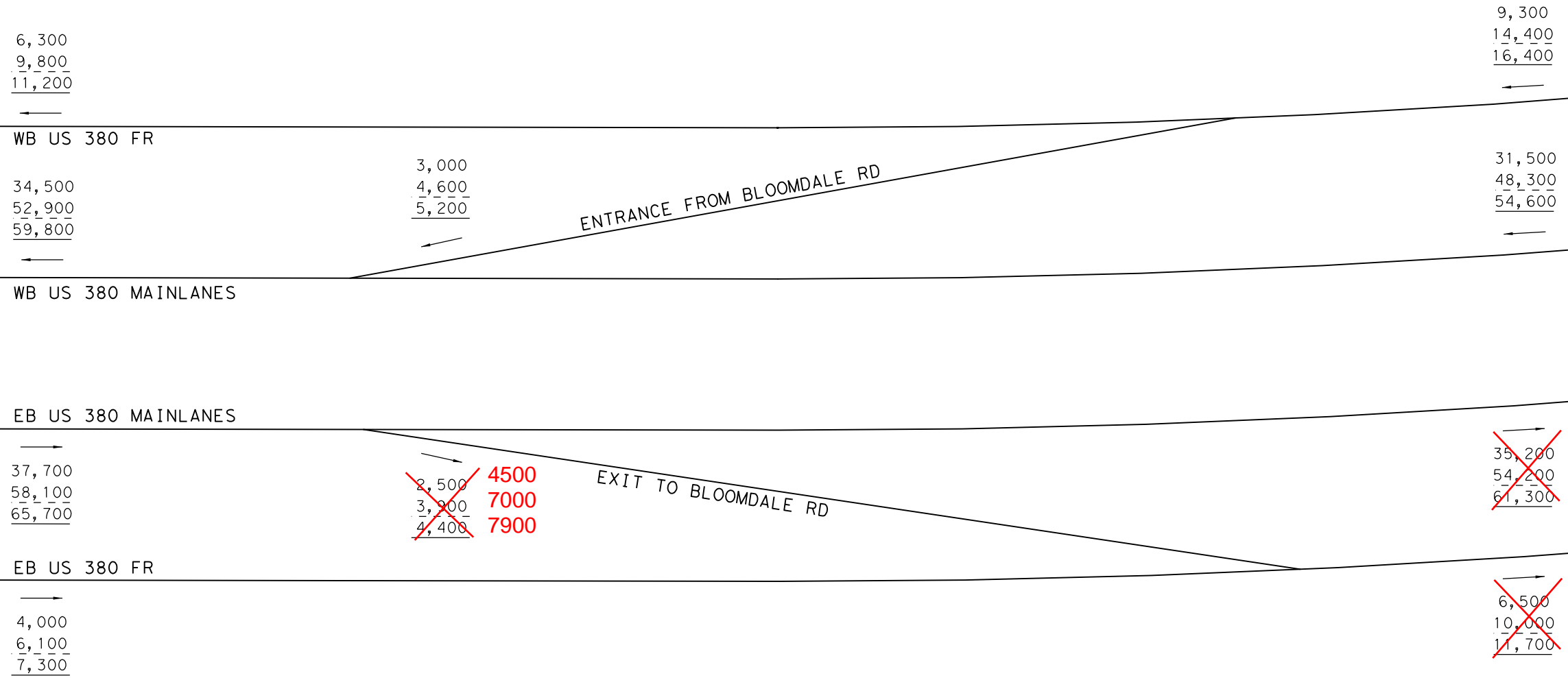
- XXXX- 2030 AVERAGE DAILY TRAFFIC VOLUMES
- XXXX- 2050 AVERAGE DAILY TRAFFIC VOLUMES
- XXXX- 2060 AVERAGE DAILY TRAFFIC VOLUMES

DATE: 7/13/2021
 FILE: US380_GOLD_TRF_10.dgn



SEE SHEET 10 OF 61

SEE SHEET 12 OF 61



LEGEND

- XXXX- 2030 AVERAGE DAILY TRAFFIC VOLUMES
- XXXX- 2050 AVERAGE DAILY TRAFFIC VOLUMES
- XXXX- 2060 AVERAGE DAILY TRAFFIC VOLUMES

NOT TO SCALE

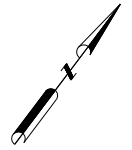
NOT INTENDED FOR CONSTRUCTION,
 BIDDING OR PERMIT PURPOSES
 DHRUVA LAHON, P.E.
 SERIAL NUMBER 102185

US 380 GOLD ALT AND
 RAMPS
 AVERAGE DAILY TRAFFIC
 GOLD ALT BUILD VOLUMES



0135-02-065,
ETC.

SHEET 11 OF 61



9,300
14,400
16,400

WB US 380 FR

31,500
48,300
54,600

WB US 380 MAINLANES

EB US 380 MAINLANES

~~35,200~~ **33200**
~~54,200~~ **51100**
~~61,300~~ **57800**

EB US 380 FR

~~6,500~~ **8500**
~~10,000~~ **13100**
~~11,700~~ **15200**

EXIT TO N STONEBRIDGE DR

3,000
4,600
5,200

ENTRANCE FROM N STONEBRIDGE DR

2000
3100
3500

6,300
9,800
11,200

34,500
52,900
59,800

35,200
54,200
61,300

6,500
10,000
11,700

SEE SHEET 11 OF 61

SEE SHEET 13 OF 61

NOT TO SCALE

NOT INTENDED FOR CONSTRUCTION,
BIDDING OR PERMIT PURPOSES
DHURVA LAHON, P.E.
SERIAL NUMBER 102185

US 380 GOLD ALT AND
RAMPS
AVERAGE DAILY TRAFFIC
GOLD ALT BUILD VOLUMES

Kimley»Horn
F-928

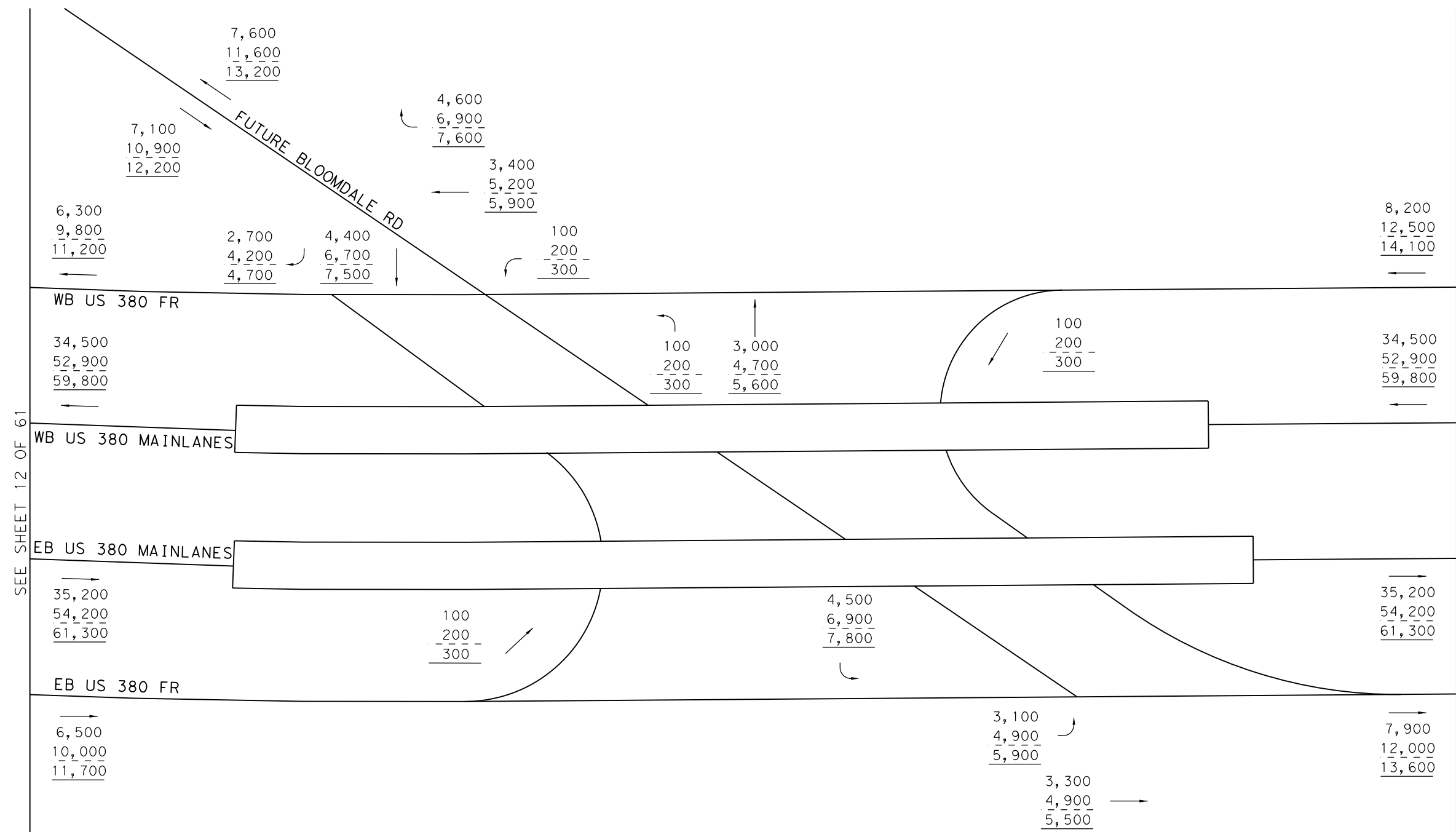
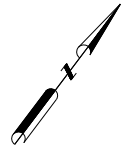
0135-02-065,
ETC.

SHEET 12 OF 61

LEGEND

- XXXX- 2030 AVERAGE DAILY TRAFFIC VOLUMES
- XXXX- 2050 AVERAGE DAILY TRAFFIC VOLUMES
- XXXX- 2060 AVERAGE DAILY TRAFFIC VOLUMES

DATE: 7/13/2021
FILE: US380_GOLD_TRF_12.dgn



SEE SHEET 12 OF 61

SEE SHEET 14 OF 61

NOT TO SCALE

NOT INTENDED FOR CONSTRUCTION,
 BIDDING OR PERMIT PURPOSES
 DHRUVA LAHON, P.E.
 SERIAL NUMBER 102185

US 380 GOLD ALT AND
 W BLOOMDALE RD
 AVERAGE DAILY TRAFFIC
 GOLD ALT BUILD VOLUMES

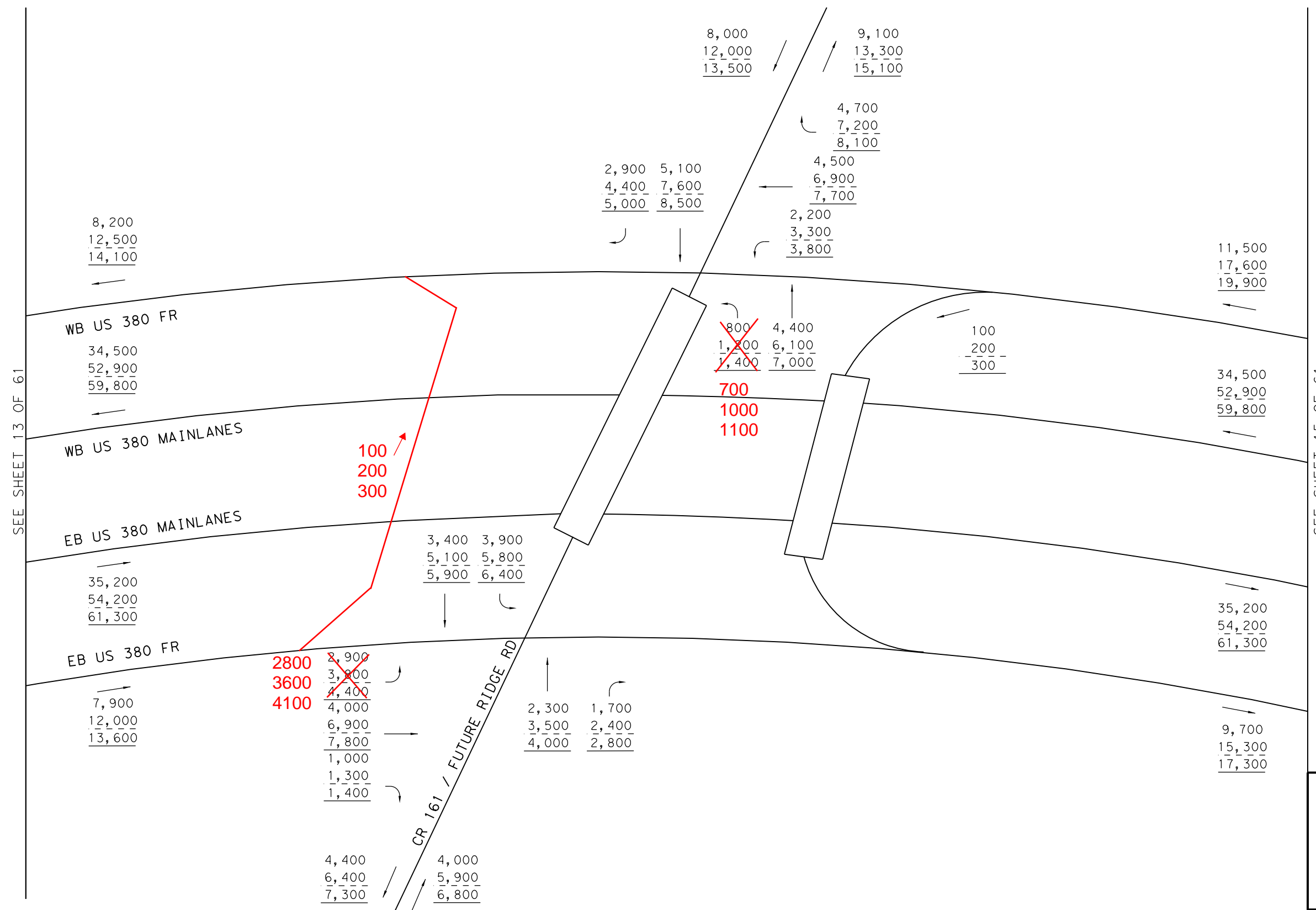


0135-02-065,
 ETC. SHEET 13 OF 61

LEGEND

- XXXX- 2030 AVERAGE DAILY TRAFFIC VOLUMES
- XXX- 2050 AVERAGE DAILY TRAFFIC VOLUMES
- XX- 2060 AVERAGE DAILY TRAFFIC VOLUMES

DATE: 7/13/2021
 FILE: US380_GOLD_TRF_13.dgn



SEE SHEET 13 OF 61

SEE SHEET 15 OF 61

NOT TO SCALE

NOT INTENDED FOR CONSTRUCTION,
 BIDDING OR PERMIT PURPOSES
 DHRUVA LAHON, P.E.
 SERIAL NUMBER 102185

US 380 GOLD ALT AND
 WILMETH RD
 AVERAGE DAILY TRAFFIC
 GOLD ALT BUILD VOLUMES

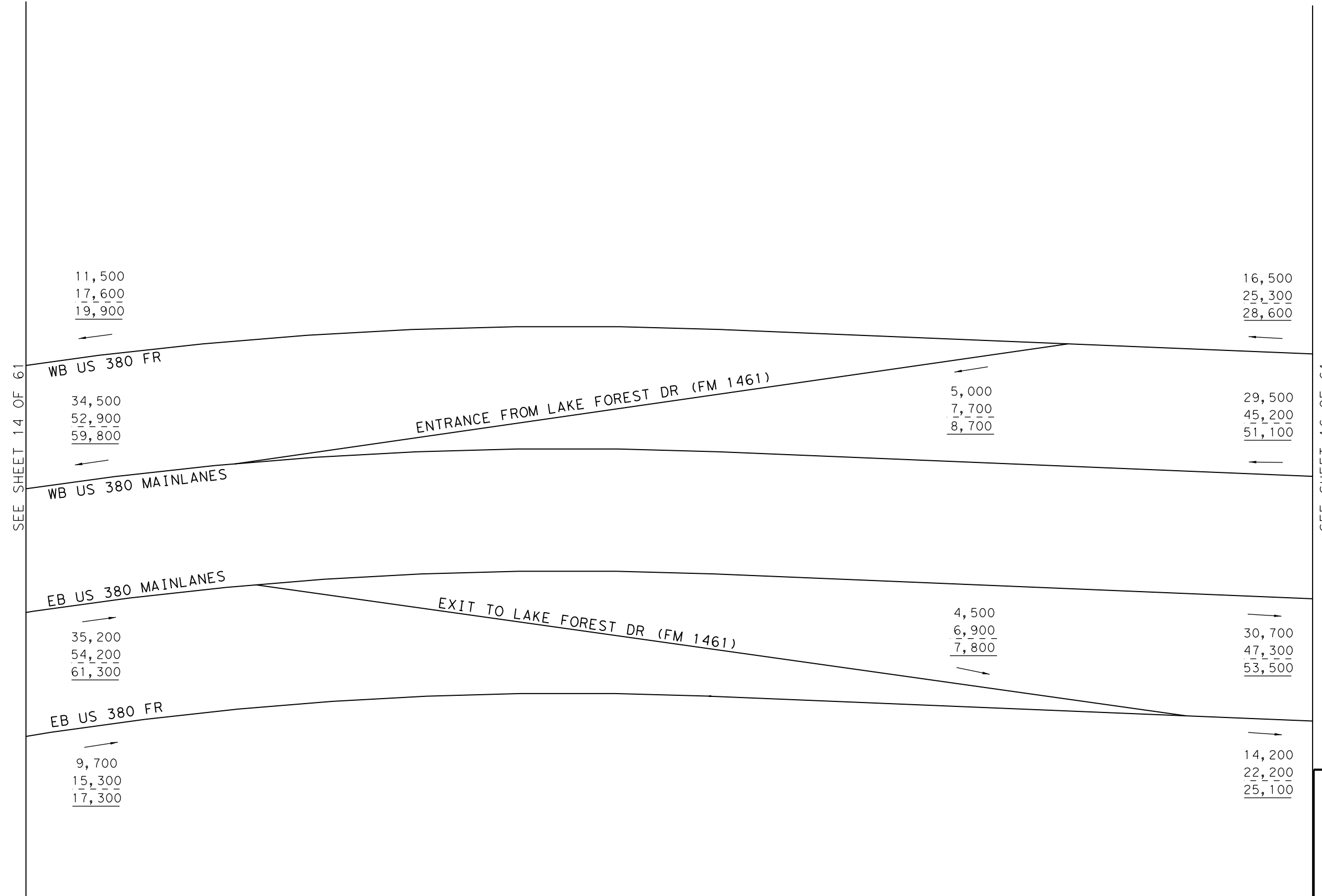
Kimley»Horn
F-928

0135-02-065,
 ETC. SHEET 14 OF 61

LEGEND

- XXXX- 2030 AVERAGE DAILY TRAFFIC VOLUMES
- XXXX- 2050 AVERAGE DAILY TRAFFIC VOLUMES
- XXXX- 2060 AVERAGE DAILY TRAFFIC VOLUMES

DATE: 7/13/2021
 FILE: US380_GOLD_TRF_14.dgn



NOT TO SCALE

NOT INTENDED FOR CONSTRUCTION,
 BIDDING OR PERMIT PURPOSES
 DHRUVA LAHON, P.E.
 SERIAL NUMBER 102185

US 380 GOLD ALT AND
 RAMPS
 AVERAGE DAILY TRAFFIC
 GOLD ALT BUILD VOLUMES



LEGEND

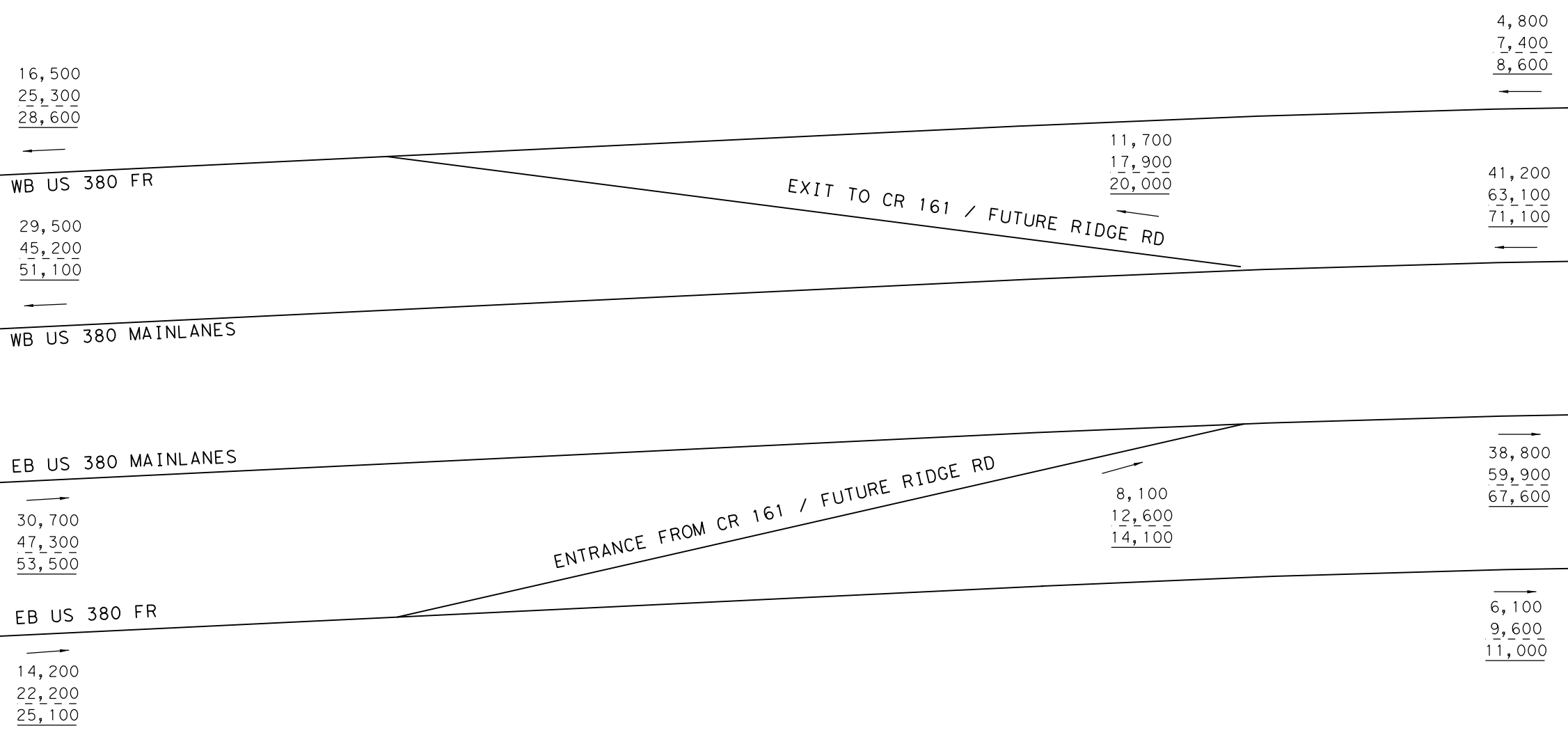
- XXXX- 2030 AVERAGE DAILY TRAFFIC VOLUMES
- XXXX- 2050 AVERAGE DAILY TRAFFIC VOLUMES
- XXXX- 2060 AVERAGE DAILY TRAFFIC VOLUMES

DATE: 7/13/2021
 FILE: US380_GOLD_TRF_15.dgn



SEE SHEET 15 OF 61

SEE SHEET 17 OF 61



NOT TO SCALE

NOT INTENDED FOR CONSTRUCTION,
 BIDDING OR PERMIT PURPOSES
 DHRUVA LAHON, P.E.
 SERIAL NUMBER 102185

US 380 GOLD ALT AND
 RAMPS
 AVERAGE DAILY TRAFFIC
 GOLD ALT BUILD VOLUMES

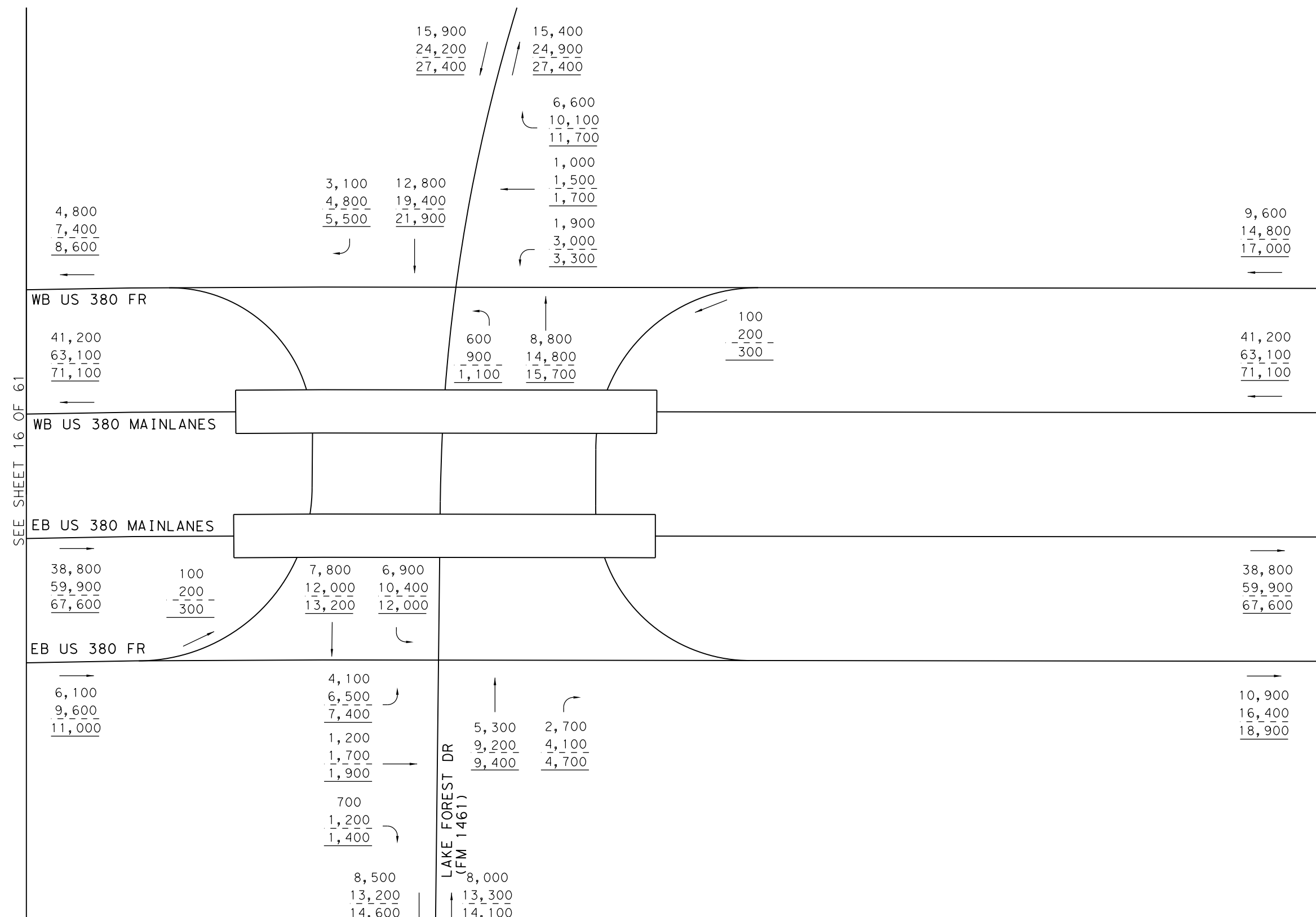


0135-02-065,
 ETC. SHEET 16 OF 61

LEGEND

- XXXX- 2030 AVERAGE DAILY TRAFFIC VOLUMES
- XXXX- 2050 AVERAGE DAILY TRAFFIC VOLUMES
- XXXX- 2060 AVERAGE DAILY TRAFFIC VOLUMES

DATE: 7/13/2021
FILE: US380_GOLD_TRF_16.dgn



SEE SHEET 16 OF 61

SEE SHEET 18 OF 61

NOT TO SCALE

NOT INTENDED FOR CONSTRUCTION,
 BIDDING OR PERMIT PURPOSES
 DHRUVA LAHON, P.E.
 SERIAL NUMBER 102185

US 380 GOLD ALT AND
 LAKE FOREST DR
 AVERAGE DAILY TRAFFIC
 GOLD ALT BUILD VOLUMES



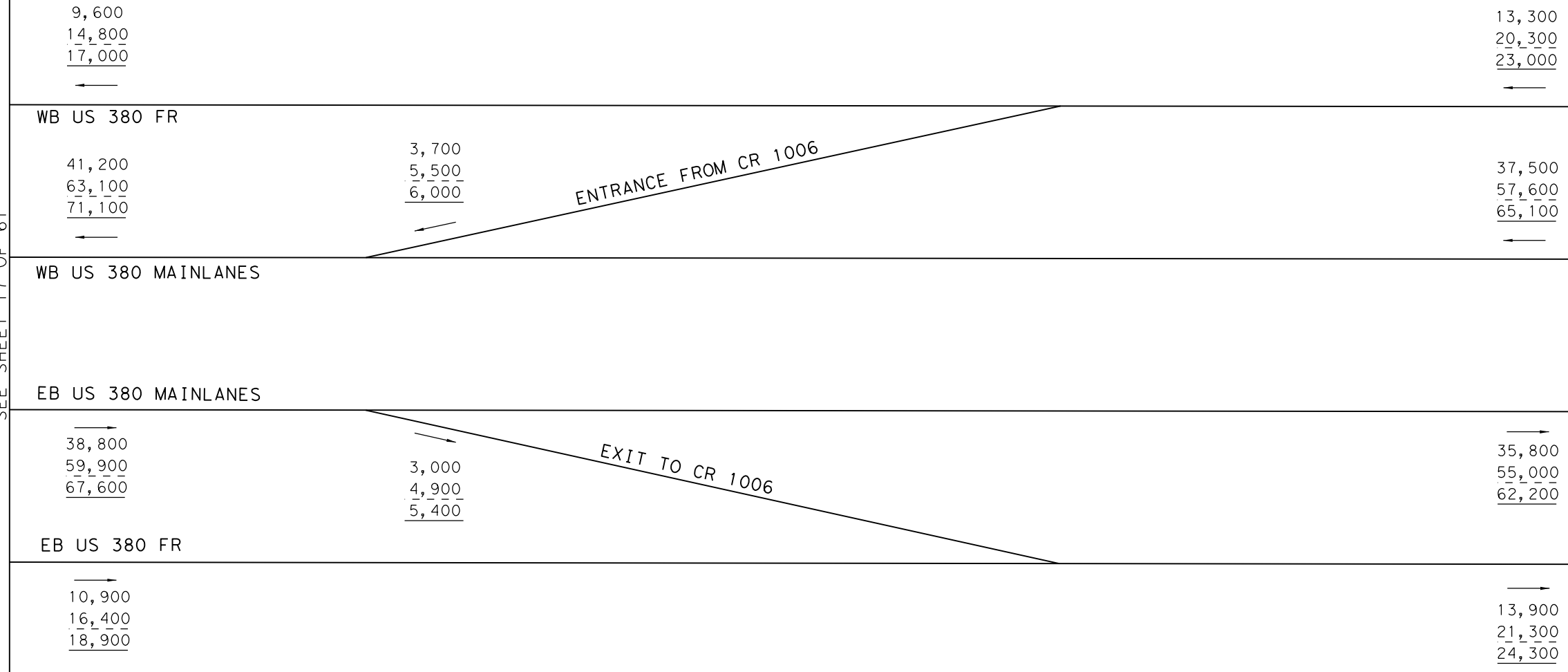
LEGEND

- XXXX- 2030 AVERAGE DAILY TRAFFIC VOLUMES
- XXXX- 2050 AVERAGE DAILY TRAFFIC VOLUMES
- XXXX- 2060 AVERAGE DAILY TRAFFIC VOLUMES



SEE SHEET 17 OF 61

SEE SHEET 19 OF 61



NOT TO SCALE

NOT INTENDED FOR CONSTRUCTION,
 BIDDING OR PERMIT PURPOSES
 DHRUVA LAHON, P.E.
 SERIAL NUMBER 102185

US 380 GOLD ALT AND
 RAMPS
 AVERAGE DAILY TRAFFIC
 GOLD ALT BUILD VOLUMES



0135-02-065,
 ETC. SHEET 18 OF 61

LEGEND

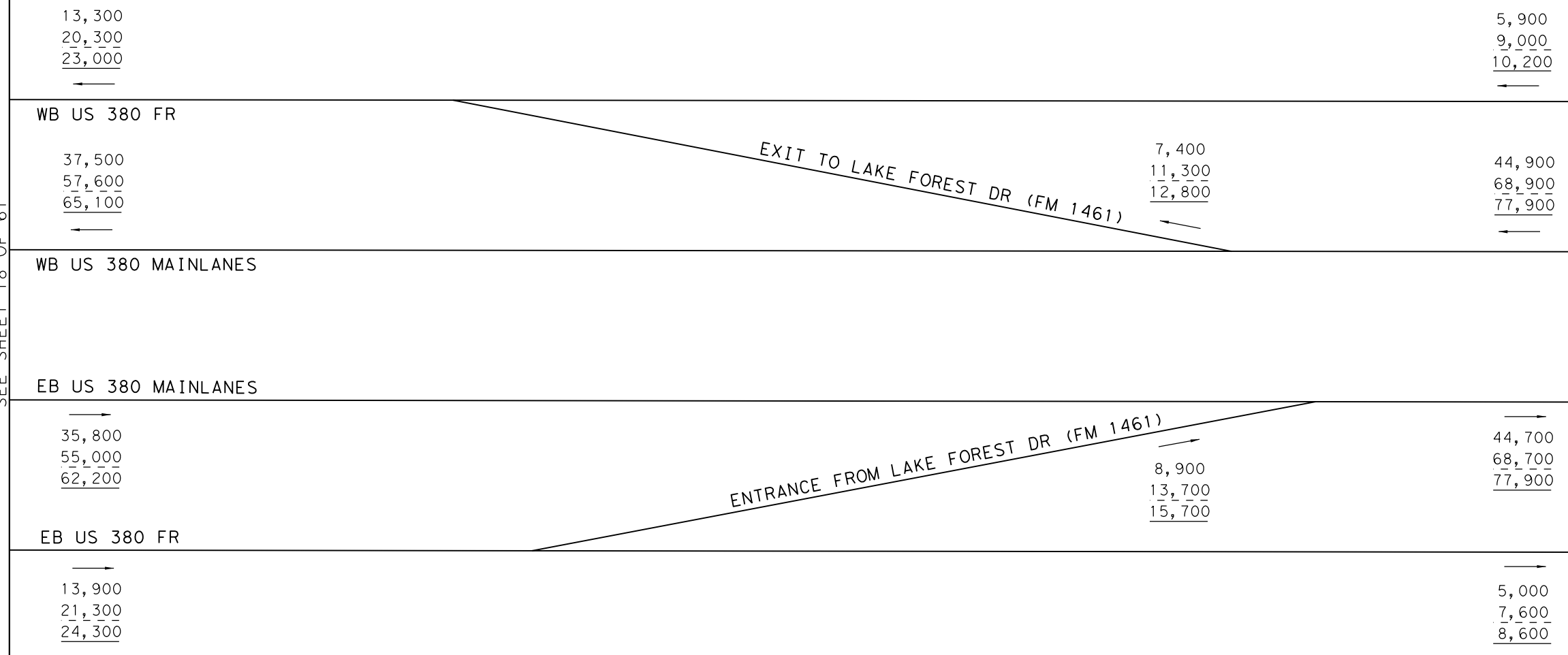
- XXXX- 2030 AVERAGE DAILY TRAFFIC VOLUMES
- XXXX- 2050 AVERAGE DAILY TRAFFIC VOLUMES
- XXXX- 2060 AVERAGE DAILY TRAFFIC VOLUMES

DATE: 7/13/2021
FILE: US380_GOLD_TRF_18.dgn



SEE SHEET 18 OF 61

SEE SHEET 20 OF 61



NOT TO SCALE

NOT INTENDED FOR CONSTRUCTION,
 BIDDING OR PERMIT PURPOSES
 DHRUVA LAHON, P.E.
 SERIAL NUMBER 102185

US 380 GOLD ALT AND
 RAMPS
 AVERAGE DAILY TRAFFIC
 GOLD ALT BUILD VOLUMES



0135-02-065,
 ETC. SHEET 19 OF 61

LEGEND

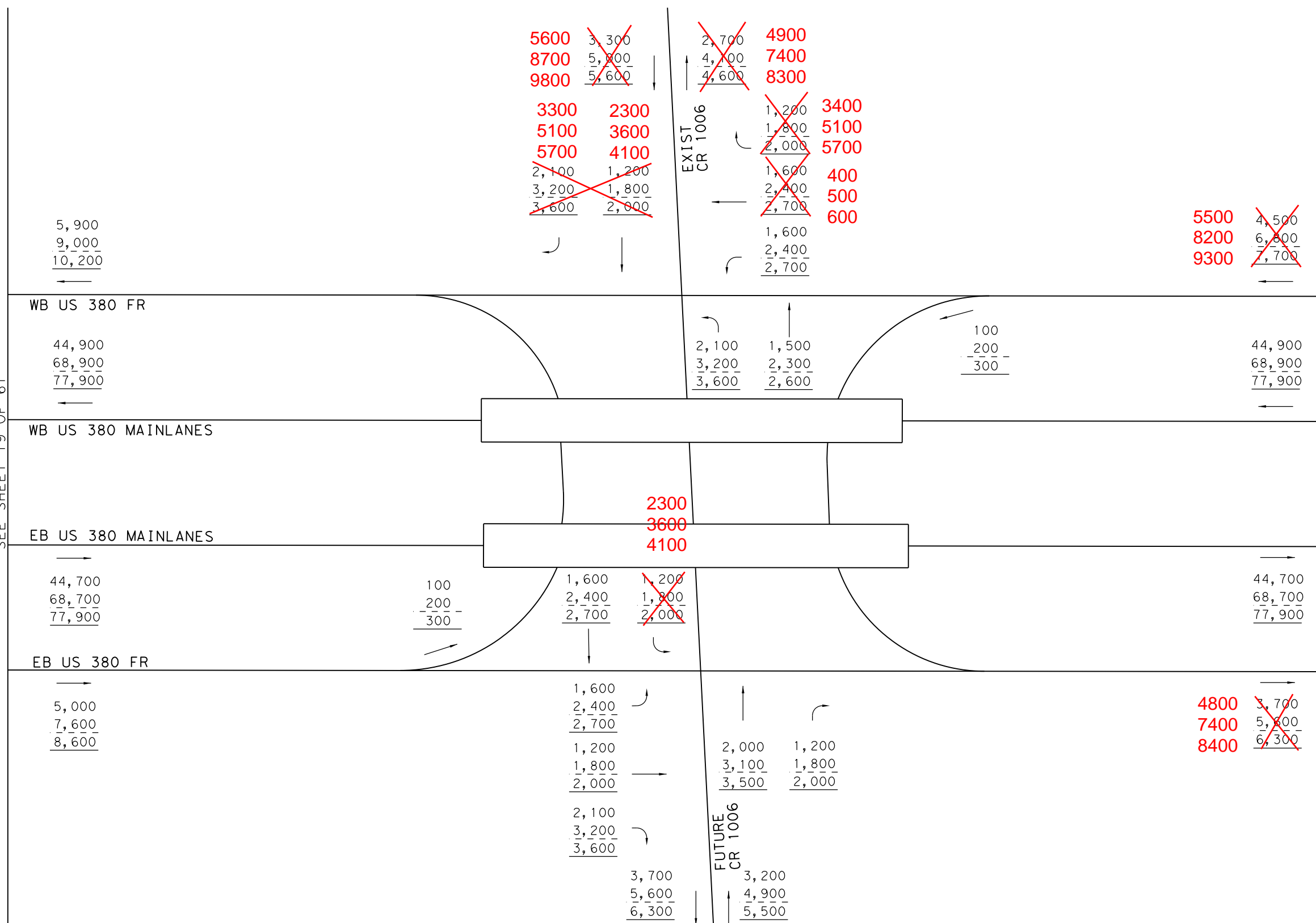
- XXXX- 2030 AVERAGE DAILY TRAFFIC VOLUMES
- XXXX- 2050 AVERAGE DAILY TRAFFIC VOLUMES
- XXXX- 2060 AVERAGE DAILY TRAFFIC VOLUMES

DATE: 7/13/2021
 FILE: US380_GOLD_TRF_19.dgn



SEE SHEET 19 OF 61

SEE SHEET 21 OF 61



LEGEND

XXXX-	2030	AVERAGE	DAILY	TRAFFIC	VOLUMES
-XXXX-	2050	AVERAGE	DAILY	TRAFFIC	VOLUMES
XXXX-	2060	AVERAGE	DAILY	TRAFFIC	VOLUMES

NOT TO SCALE

NOT INTENDED FOR CONSTRUCTION,
 BIDDING OR PERMIT PURPOSES
 DHRUVA LAHON, P.E.
 SERIAL NUMBER 102185

US 380 GOLD ALT AND
 CR 1006
 AVERAGE DAILY TRAFFIC
 GOLD ALT BUILD VOLUMES

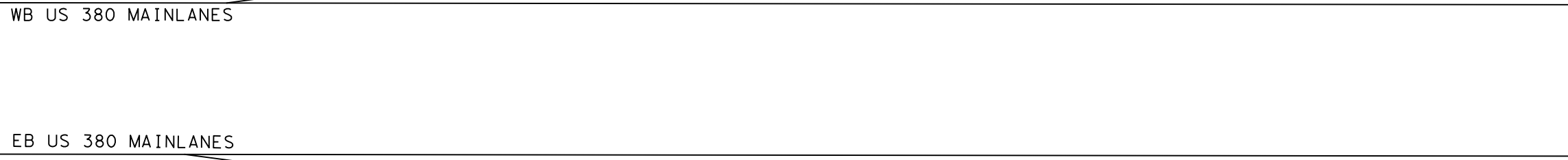
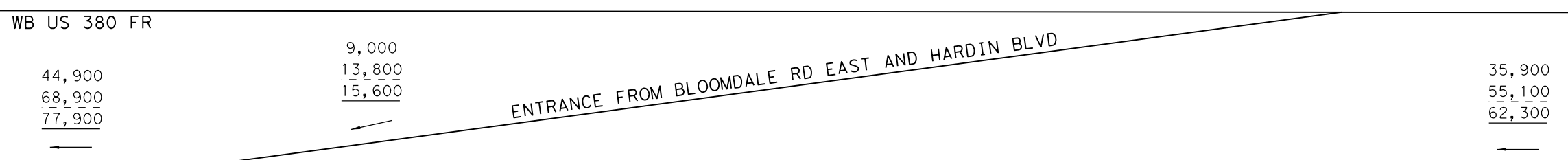


DATE: 7/13/2021
FILE: US380_GOLD_TRF_20.dgn



4,500	5500
6,800	8200
7,700	9300

14500	13,500
22000	20,600
24900	28,300



SEE SHEET 20 OF 61

SEE SHEET 22 OF 61

NOT TO SCALE

NOT INTENDED FOR CONSTRUCTION,
BIDDING OR PERMIT PURPOSES
DHURVA LAHON, P.E.
SERIAL NUMBER 102185

US 380 GOLD ALT AND
RAMPS
AVERAGE DAILY TRAFFIC
GOLD ALT BUILD VOLUMES



0135-02-065,
ETC. SHEET 21 OF 61

LEGEND

- XXXX- 2030 AVERAGE DAILY TRAFFIC VOLUMES
- XXXX- 2050 AVERAGE DAILY TRAFFIC VOLUMES
- XXXX- 2060 AVERAGE DAILY TRAFFIC VOLUMES

DATE: 7/13/2021
FILE: US380_GOLD_TRF_21.dgn



13,500	14500
20,600	22000
23,300	24900

12200	11,200
18600	17,800
21200	19,600

WB US 380 FR

35,900
<u>55,100</u>
62,300

2,300
<u>3,400</u>
3,700

38,200
<u>58,500</u>
66,000

WB US 380 MAINLANES

EXIT TO CR 1006

EB US 380 MAINLANES

35,800
<u>55,000</u>
62,200

2,000
<u>2,800</u>
3,100

37,800
<u>57,800</u>
65,300

EB US 380 FR

ENTRANCE FROM CR 1006

12,600	13700
19,300	21100
22,000	24100

11700	10,600
18300	16,500
21000	18,900

SEE SHEET 21 OF 61

SEE SHEET 23 OF 61

NOT TO SCALE

NOT INTENDED FOR CONSTRUCTION,
BIDDING OR PERMIT PURPOSES
DHURVA LAHON, P.E.
SERIAL NUMBER 102185

US 380 GOLD ALT AND
RAMPS
AVERAGE DAILY TRAFFIC
GOLD ALT BUILD VOLUMES

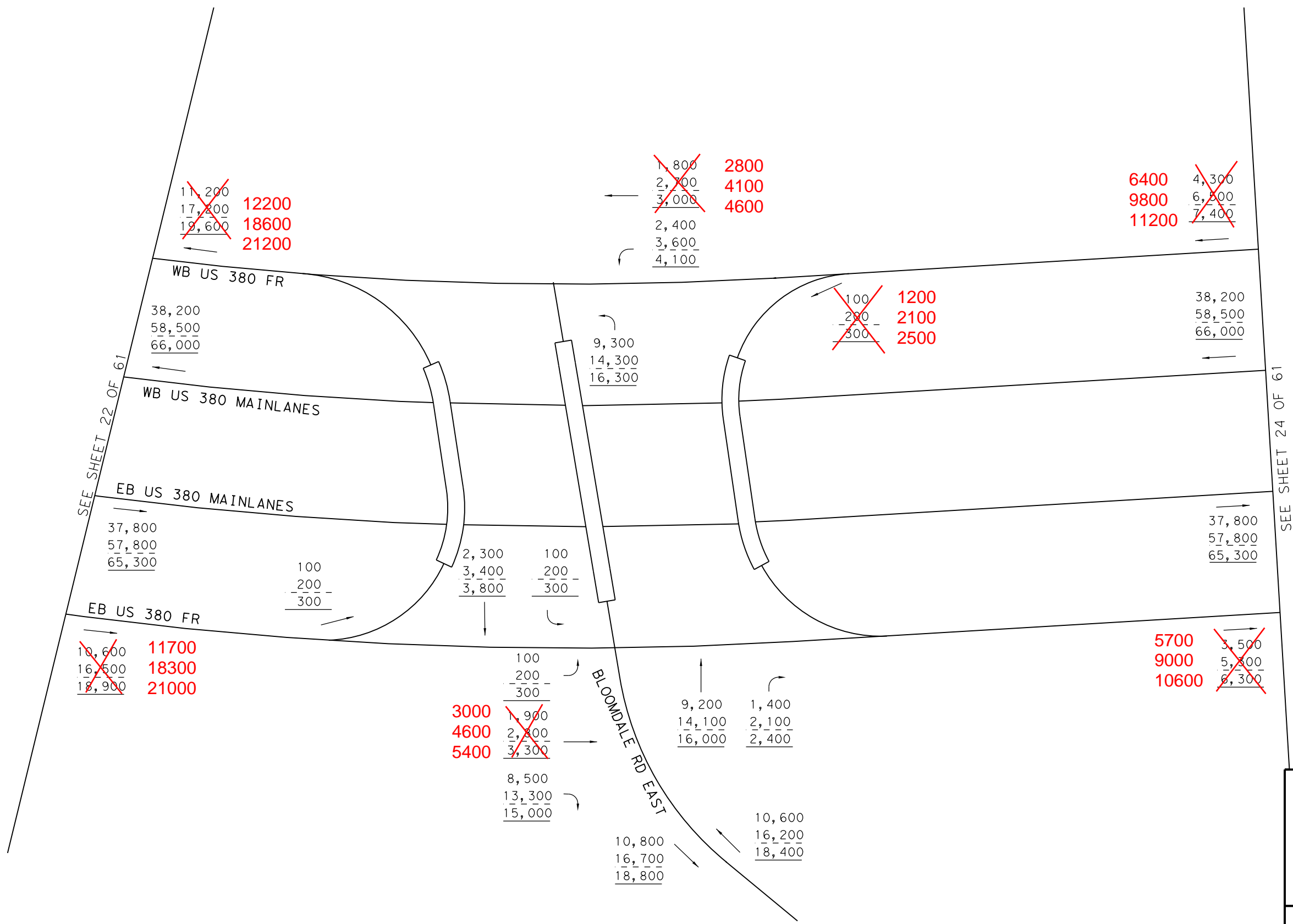
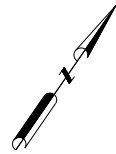
Kimley»Horn
F-928

0135-02-065,
ETC.

SHEET 22 OF 61

LEGEND

- XXXX- 2030 AVERAGE DAILY TRAFFIC VOLUMES
- XXXX- 2050 AVERAGE DAILY TRAFFIC VOLUMES
- XXXX- 2060 AVERAGE DAILY TRAFFIC VOLUMES



NOT TO SCALE

NOT INTENDED FOR CONSTRUCTION,
BIDDING OR PERMIT PURPOSES
DHURVA LAHON, P.E.
SERIAL NUMBER 102185

US 380 GOLD ALT AND
E BLOOMDALE RD
AVERAGE DAILY TRAFFIC
GOLD ALT BUILD VOLUMES

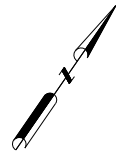
Kimley»Horn

0135-02-065, ETC. SHEET 23 OF 61

LEGEND

- XXXX- 2030 AVERAGE DAILY TRAFFIC VOLUMES
- XXXX- 2050 AVERAGE DAILY TRAFFIC VOLUMES
- XXXX- 2060 AVERAGE DAILY TRAFFIC VOLUMES

DATE: 7/13/2021
FILE: US380_GOLD_TRF_23.dgn



RD 201
 2400
 3700
 4200

2200
 3300
 3800

2400
 3700
 4200

2200
 3300
 3800
 4000
 6100
 7000

6200
 9400
 10800

~~4,300~~
~~6,500~~
~~7,400~~

6400
 9800
 11200

WB US 380 FR

38,200
 58,500
 66,000

38,200
 58,500
 66,000

WB US 380 MAINLANES

EB US 380 MAINLANES

37,800
 57,800
 65,300

37,800
 57,800
 65,300

EB US 380 FR

~~3,500~~
~~5,700~~
~~6,300~~

5700
 9000
 10600

5700
 9000
 10600

SEE SHEET 23 OF 61

SEE SHEET 25 OF 61

NOT TO SCALE

NOT INTENDED FOR CONSTRUCTION,
 BIDDING OR PERMIT PURPOSES
 DHRUVA LAHON, P.E.
 SERIAL NUMBER 102185

US 380 GOLD ALT

AVERAGE DAILY TRAFFIC
 GOLD ALT BUILD VOLUMES

Kimley»Horn

F-928

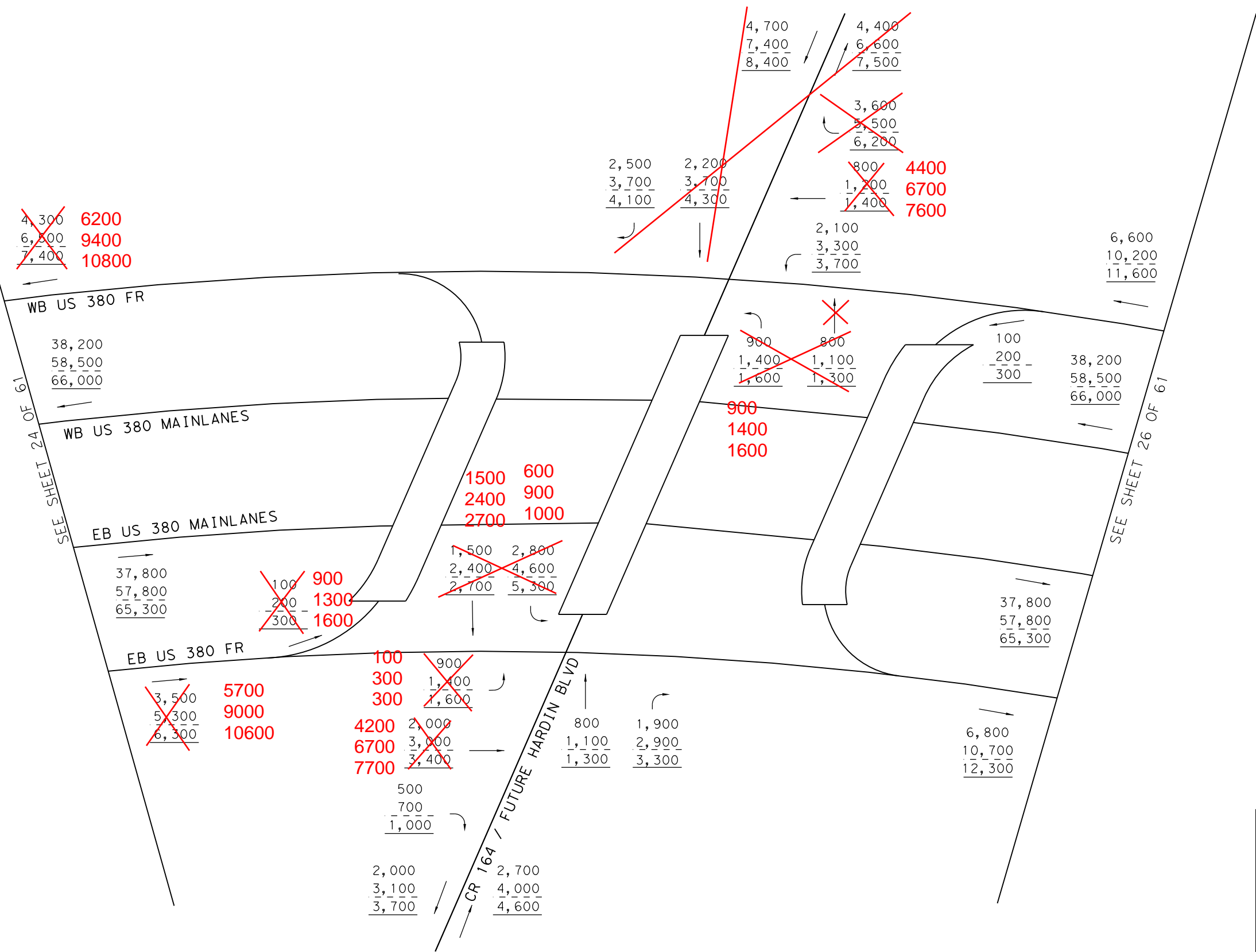
0135-02-065,
 ETC.

SHEET 24 OF 61

LEGEND

- XXXX- 2030 AVERAGE DAILY TRAFFIC VOLUMES
- XXXX- 2050 AVERAGE DAILY TRAFFIC VOLUMES
- XXXX- 2060 AVERAGE DAILY TRAFFIC VOLUMES

DATE: 7/13/2021
 FILE: US380_GOLD_TRF_24.dgn



SEE SHEET 24 OF 61

SEE SHEET 26 OF 61

LEGEND

- XXXX- 2030 AVERAGE DAILY TRAFFIC VOLUMES
- XXXX- 2050 AVERAGE DAILY TRAFFIC VOLUMES
- XXXX- 2060 AVERAGE DAILY TRAFFIC VOLUMES

NOT TO SCALE

NOT INTENDED FOR CONSTRUCTION,
 BIDDING OR PERMIT PURPOSES
 DHRUVA LAHON, P.E.
 SERIAL NUMBER 102185

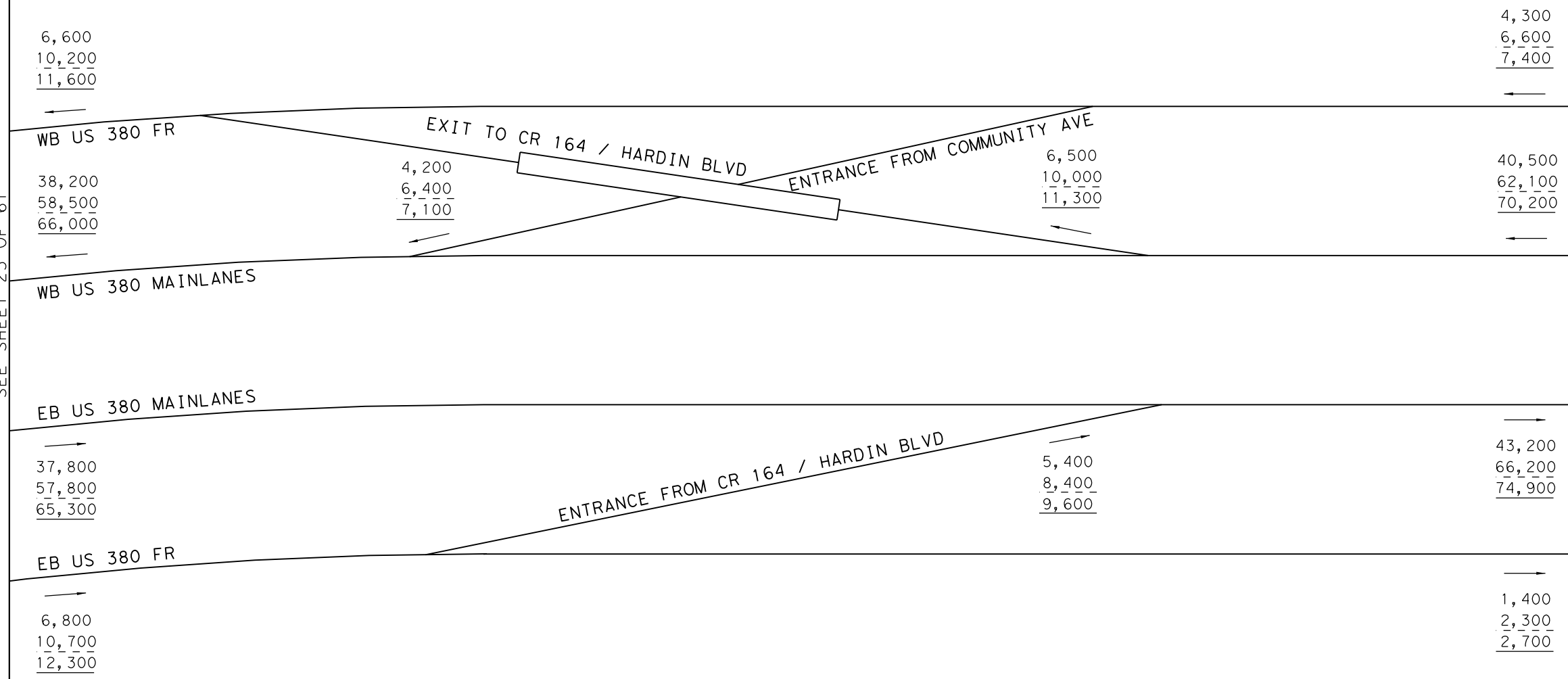
US 380 GOLD ALT AND
 CR 164
 AVERAGE DAILY TRAFFIC
 GOLD ALT BUILD VOLUMES





SEE SHEET 25 OF 61

SEE SHEET 27 OF 61



NOT TO SCALE

NOT INTENDED FOR CONSTRUCTION,
 BIDDING OR PERMIT PURPOSES
 DHRUVA LAHON, P.E.
 SERIAL NUMBER 102185

US 380 GOLD ALT AND
 RAMPS
 AVERAGE DAILY TRAFFIC
 GOLD ALT BUILD VOLUMES



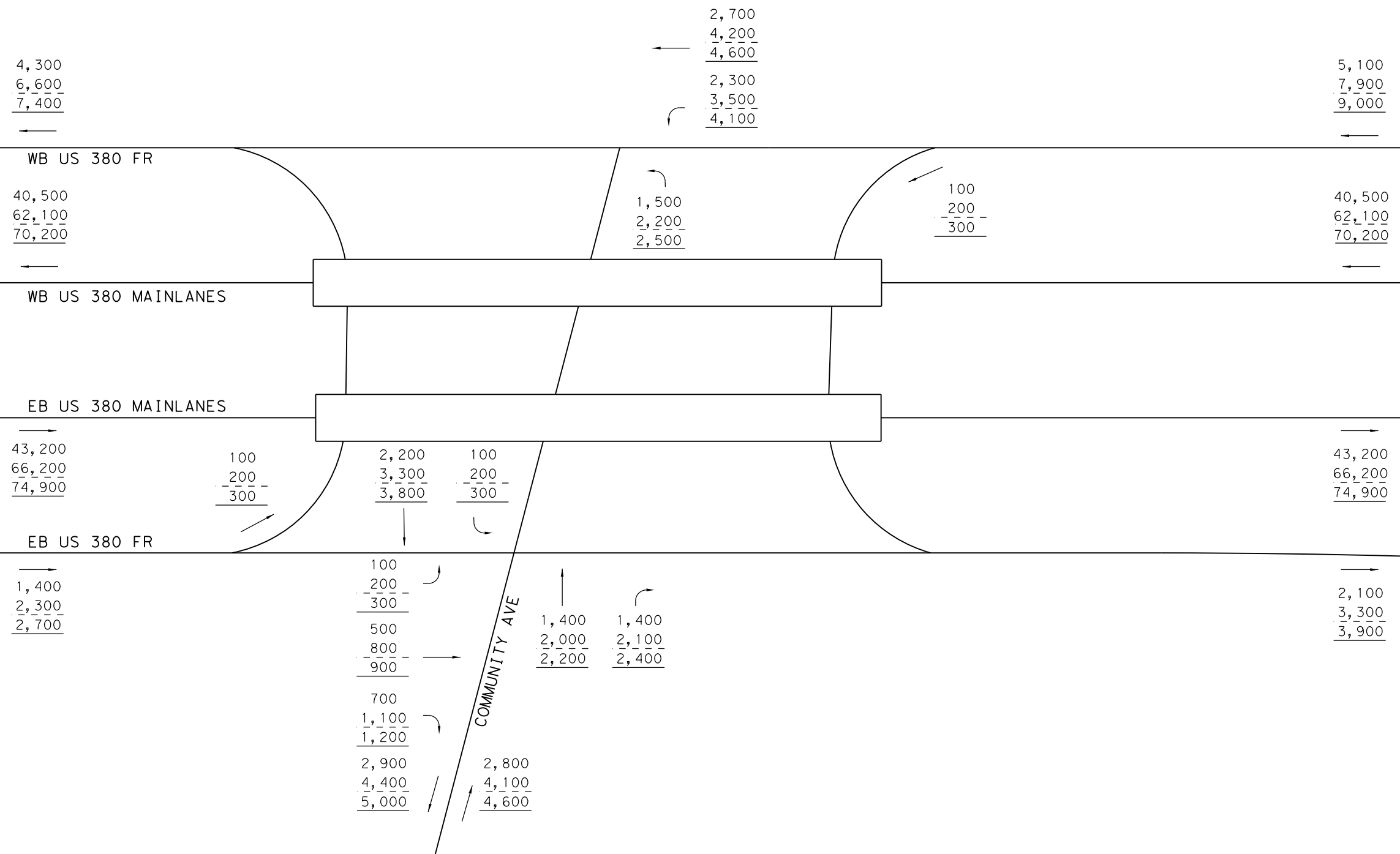
LEGEND

- XXXX- 2030 AVERAGE DAILY TRAFFIC VOLUMES
- XXXX- 2050 AVERAGE DAILY TRAFFIC VOLUMES
- XXXX- 2060 AVERAGE DAILY TRAFFIC VOLUMES



SEE SHEET 26 OF 61

SEE SHEET 28 OF 61



NOT TO SCALE

NOT INTENDED FOR CONSTRUCTION,
 BIDDING OR PERMIT PURPOSES
 DHRUVA LAHON, P.E.
 SERIAL NUMBER 102185

US 380 GOLD ALT AND
 COMMUNITY AVE
 AVERAGE DAILY TRAFFIC
 GOLD ALT BUILD VOLUMES

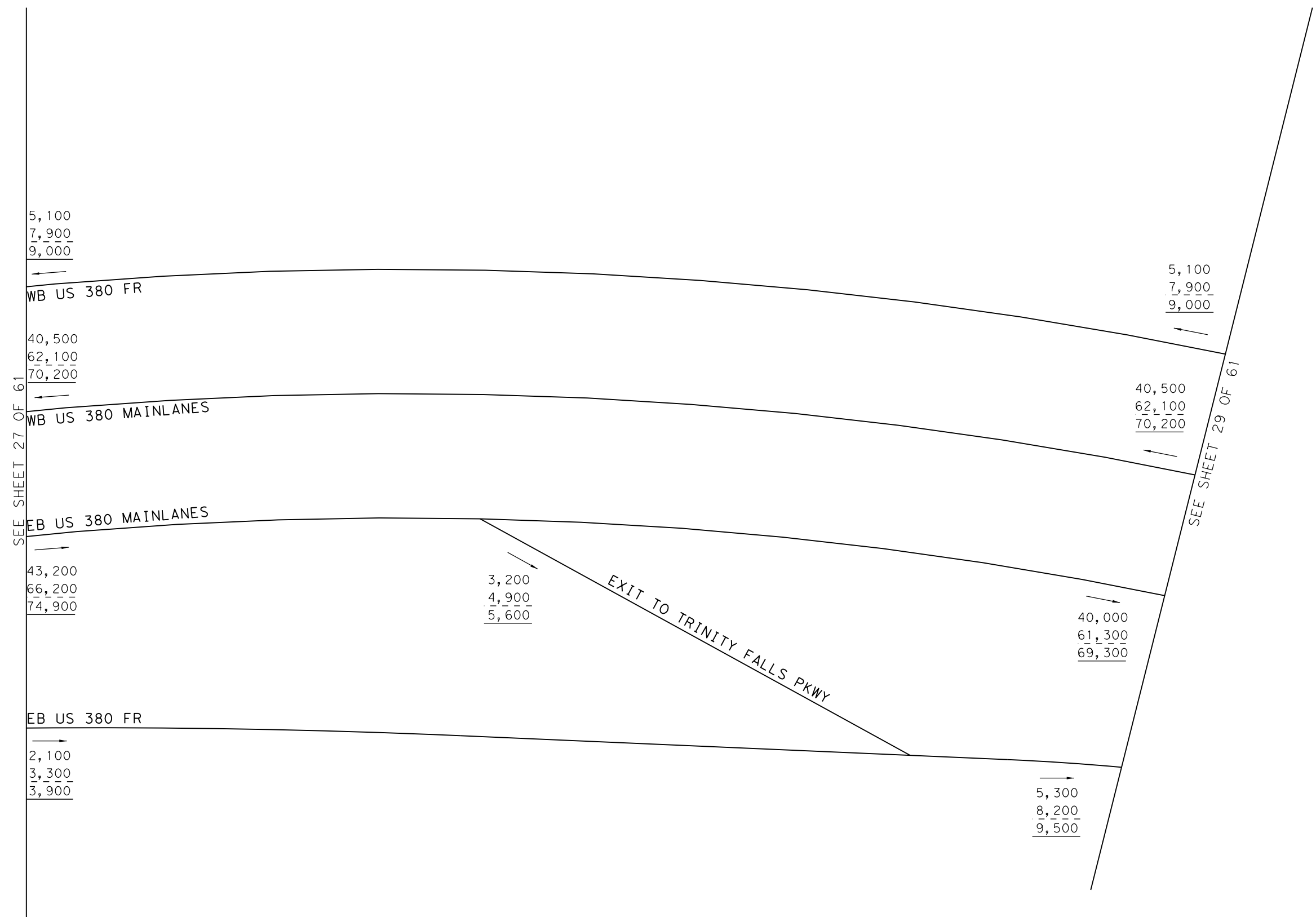


0135-02-065,
 ETC. SHEET 27 OF 61

LEGEND

- XXXX- 2030 AVERAGE DAILY TRAFFIC VOLUMES
- XXXX- 2050 AVERAGE DAILY TRAFFIC VOLUMES
- XXXX- 2060 AVERAGE DAILY TRAFFIC VOLUMES

DATE: 7/13/2021
 FILE: US380_GOLD_TRF_27.dgn



5,100
7,900
 9,000

WB US 380 FR

40,500
62,100
 70,200

WB US 380 MAINLANES

EB US 380 MAINLANES

43,200
66,200
 74,900

EB US 380 FR

2,100
3,300
 3,900

5,100
7,900
 9,000

40,500
62,100
 70,200

3,200
4,900
 5,600

40,000
61,300
 69,300

5,300
8,200
 9,500

SEE SHEET 27 OF 61

SEE SHEET 29 OF 61

EXIT TO TRINITY FALLS PKWY

NOT TO SCALE

NOT INTENDED FOR CONSTRUCTION,
 BIDDING OR PERMIT PURPOSES
 DHRUVA LAHON, P.E.
 SERIAL NUMBER 102185

US 380 GOLD ALT AND
 RAMPS
 AVERAGE DAILY TRAFFIC
 GOLD ALT BUILD VOLUMES

Kimley»Horn
F-928

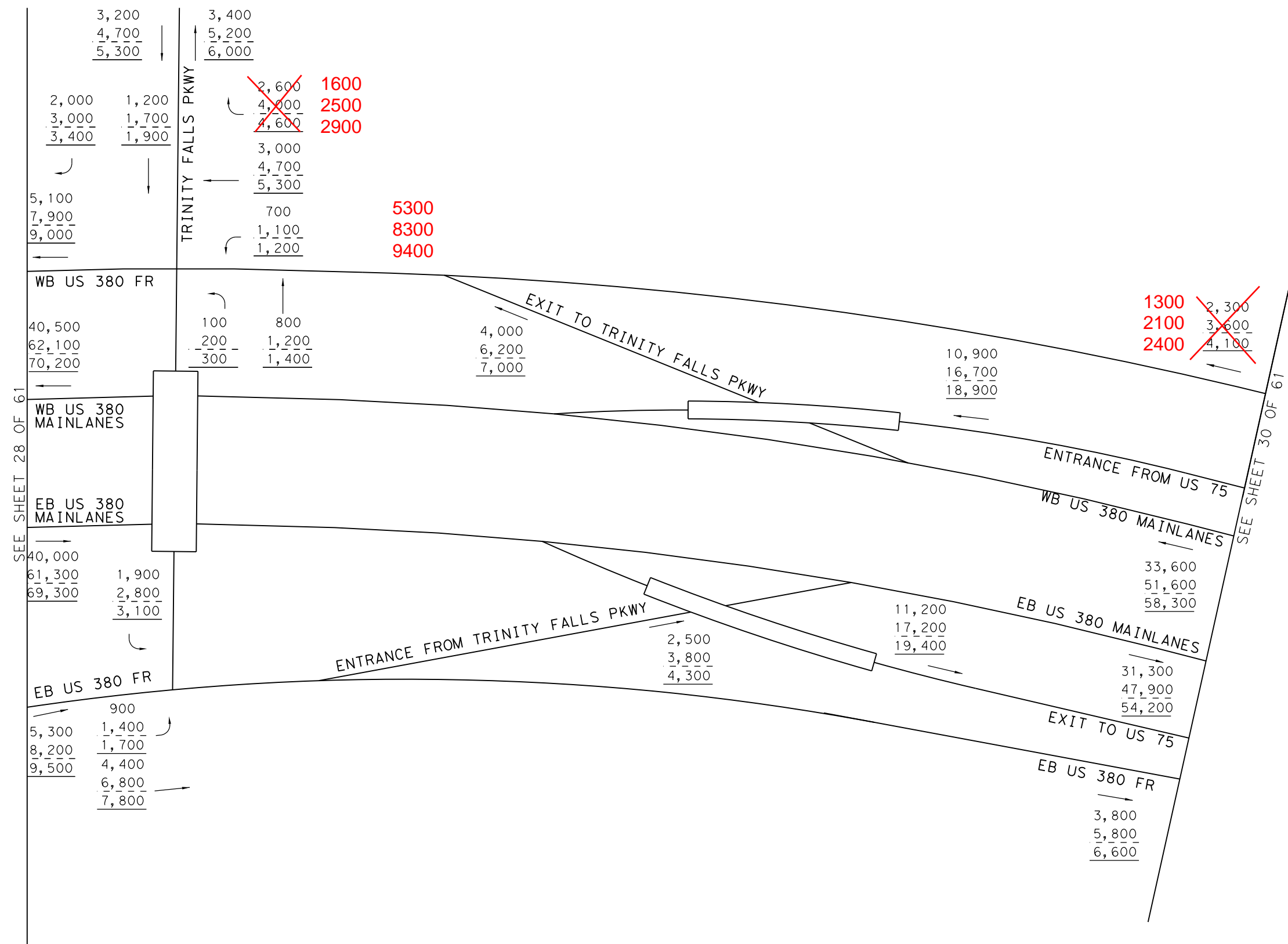
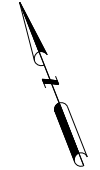
0135-02-065,
 ETC.

SHEET 28 OF 61

LEGEND

- XXXX- 2030 AVERAGE DAILY TRAFFIC VOLUMES
- XXXX- 2050 AVERAGE DAILY TRAFFIC VOLUMES
- XXXX- 2060 AVERAGE DAILY TRAFFIC VOLUMES

DATE: 7/13/2021
 FILE: US380_GOLD_TRF_28.dgn



SEE SHEET 28 OF 61

SEE SHEET 30 OF 61

LEGEND

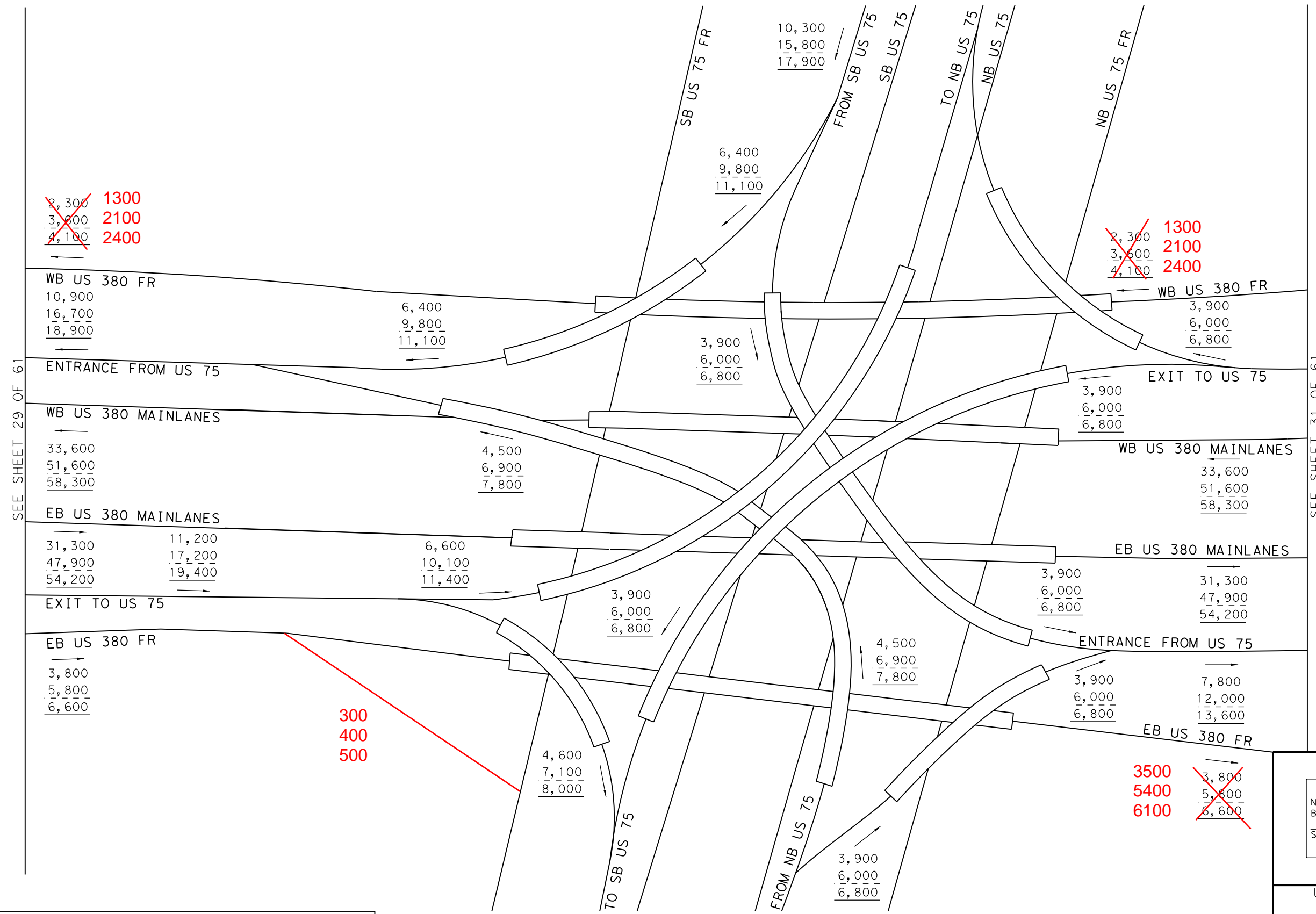
- XXXX- 2030 AVERAGE DAILY TRAFFIC VOLUMES
- XXXX- 2050 AVERAGE DAILY TRAFFIC VOLUMES
- XXXX- 2060 AVERAGE DAILY TRAFFIC VOLUMES

NOT TO SCALE

NOT INTENDED FOR CONSTRUCTION,
BIDDING OR PERMIT PURPOSES
DHURVA LAHON, P.E.
SERIAL NUMBER 102185

US 380 GOLD ALT AND
TRINITY FALLS PKWY
AVERAGE DAILY TRAFFIC
GOLD ALT BUILD VOLUMES





~~2,300~~ 1300
~~3,600~~ 2100
~~4,100~~ 2400

~~2,300~~ 1300
~~3,600~~ 2100
~~4,100~~ 2400

300
 400
 500

3500
 5400
 6100

SEE SHEET 29 OF 61

SEE SHEET 31 OF 61

NOT TO SCALE

NOT INTENDED FOR CONSTRUCTION,
 BIDDING OR PERMIT PURPOSES
 DHRUVA LAHON, P.E.
 SERIAL NUMBER 102185

US 380 GOLD ALT AND
 US 75
 AVERAGE DAILY TRAFFIC
 GOLD ALT BUILD VOLUMES

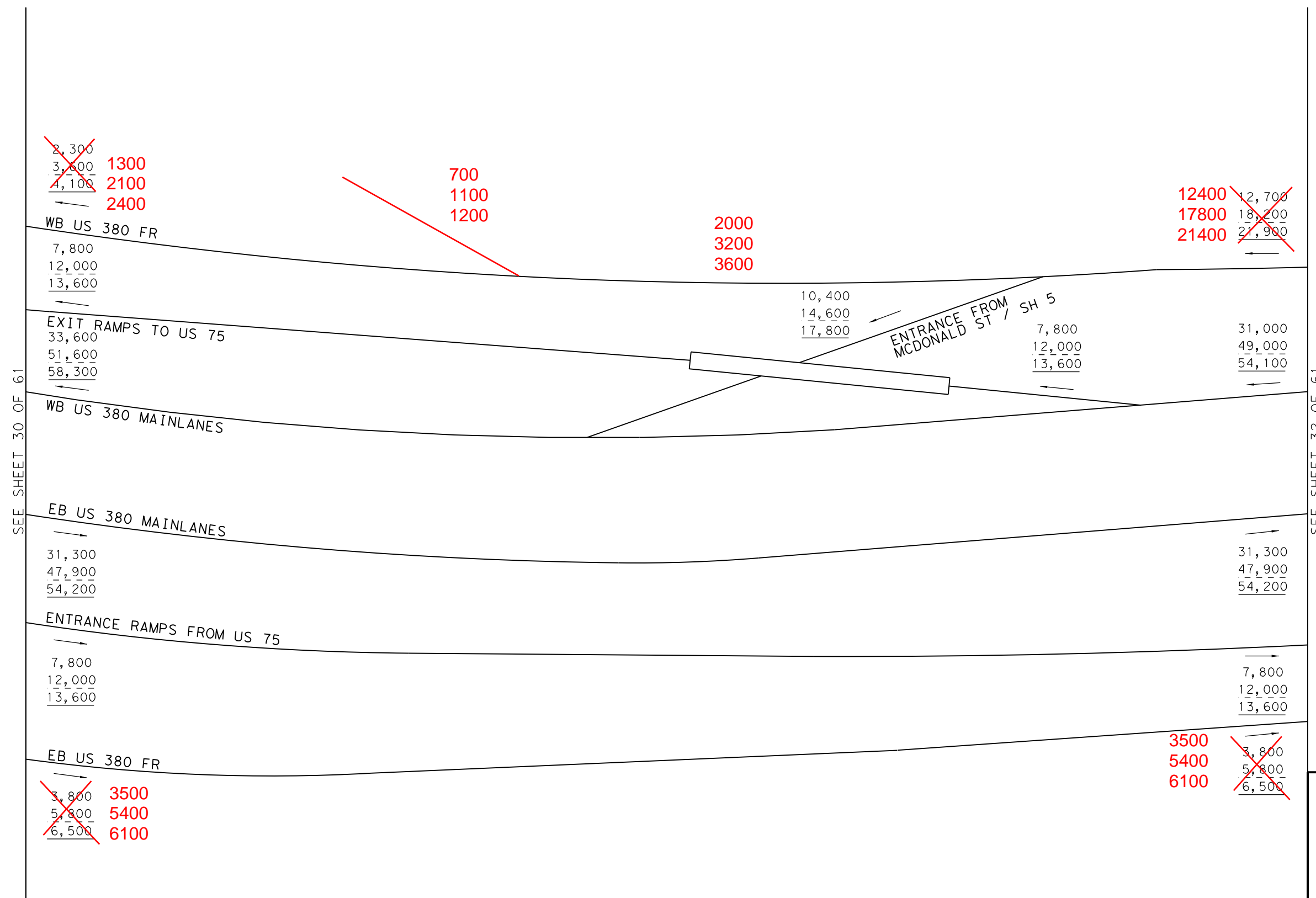
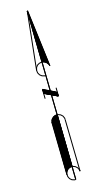
Kimley»Horn
F-928

0135-02-065,
 ETC. SHEET 30 OF 61

LEGEND

- XXXX- 2030 AVERAGE DAILY TRAFFIC VOLUMES
- XXXX- 2050 AVERAGE DAILY TRAFFIC VOLUMES
- XXXX- 2060 AVERAGE DAILY TRAFFIC VOLUMES

DATE: 7/13/2021
 FILE: US380_GOLD_TRF_30.dgn



NOT TO SCALE

NOT INTENDED FOR CONSTRUCTION,
 BIDDING OR PERMIT PURPOSES
 DHRUVA LAHON, P.E.
 SERIAL NUMBER 102185

US 380 GOLD ALT AND
 WESTON RD
 AVERAGE DAILY TRAFFIC
 GOLD ALT BUILD VOLUMES

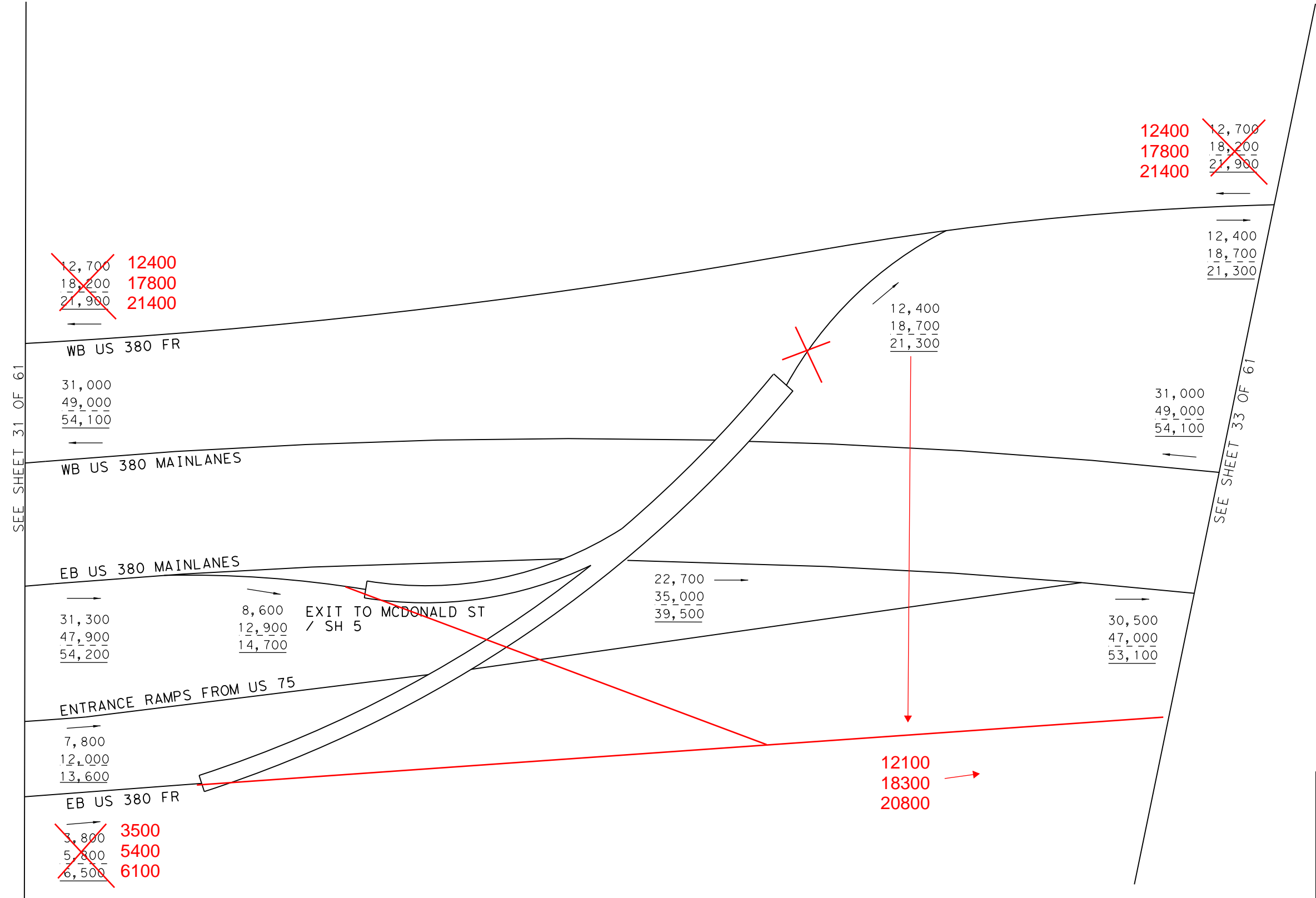
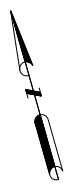


0135-02-065,
 ETC. SHEET 31 OF 61

LEGEND

- XXXX- 2030 AVERAGE DAILY TRAFFIC VOLUMES
- XXXX- 2050 AVERAGE DAILY TRAFFIC VOLUMES
- XXXX- 2060 AVERAGE DAILY TRAFFIC VOLUMES

DATE: 7/13/2021
 FILE: US380_GOLD_TRF_31.dgn



SEE SHEET 31 OF 61

SEE SHEET 33 OF 61

NOT TO SCALE

NOT INTENDED FOR CONSTRUCTION,
 BIDDING OR PERMIT PURPOSES
 DHRUVA LAHON, P.E.
 SERIAL NUMBER 102185

US 380 GOLD ALT AND
 RAMPS
 AVERAGE DAILY TRAFFIC
 GOLD ALT BUILD VOLUMES

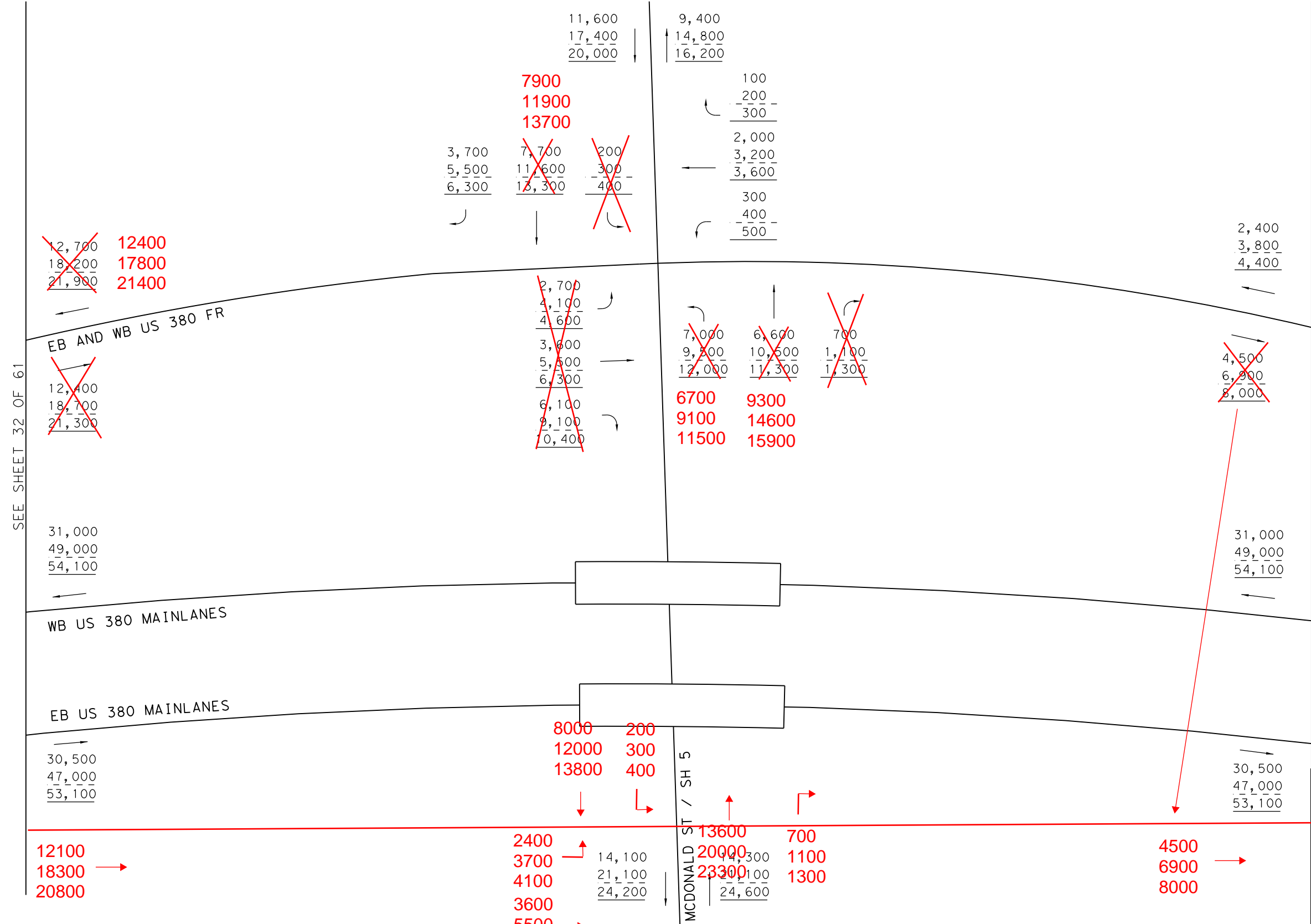
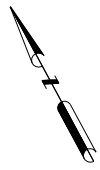
Kimley»Horn
F-928

0135-02-065,
 ETC. SHEET 32 OF 61

LEGEND

- XXXX- 2030 AVERAGE DAILY TRAFFIC VOLUMES
- XXXX- 2050 AVERAGE DAILY TRAFFIC VOLUMES
- XXXX- 2060 AVERAGE DAILY TRAFFIC VOLUMES

DATE: 7/13/2021
 FILE: US380_GOLD_TRF_32.dgn



SEE SHEET 32 OF 61

SEE SHEET 34 OF 61

NOT TO SCALE

NOT INTENDED FOR CONSTRUCTION,
 BIDDING OR PERMIT PURPOSES
 DHRUVA LAHON, P.E.
 SERIAL NUMBER 102185

US 380 GOLD ALT AND
 MCDONALD ST / SH 5
 AVERAGE DAILY TRAFFIC
 GOLD ALT BUILD VOLUMES

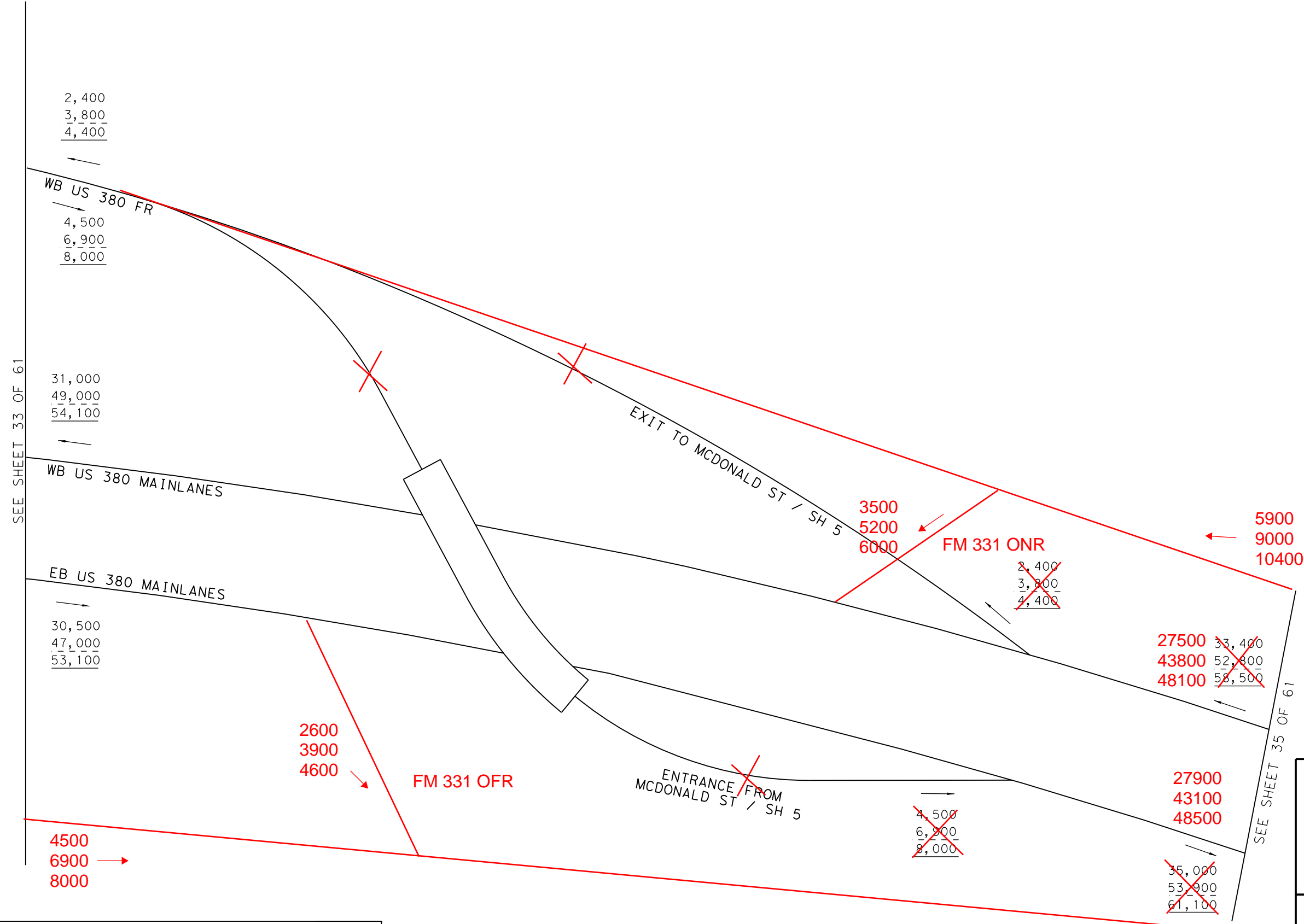
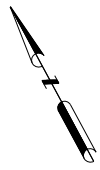
Kimley»Horn
 F-928

0135-02-065,
 ETC. SHEET 33 OF 61

LEGEND

- XXXX- 2030 AVERAGE DAILY TRAFFIC VOLUMES
- XXXX- 2050 AVERAGE DAILY TRAFFIC VOLUMES
- XXXX- 2060 AVERAGE DAILY TRAFFIC VOLUMES

DATE: 7/13/2021
 FILE: US380_GOLD_TRF_33.dgn



SEE SHEET 33 OF 61

SEE SHEET 35 OF 61

2,400
3,800
4,400

4,500
6,900
8,000

31,000
49,000
54,100

WB US 380 MAINLANES

EB US 380 MAINLANES

30,500
47,000
53,100

3500
5200
6000

FM 331 ONR

~~2,400~~
~~3,800~~
~~4,400~~

5900
9000
10400

~~33,400~~
~~52,800~~
~~58,500~~

2600
3900
4600

FM 331 OFR

ENTRANCE FROM
MCDONALD ST / SH 5

~~4,500~~
~~6,900~~
~~8,000~~

27900
43100
48500

4500
6900
8000

~~35,000~~
~~53,900~~
~~61,100~~

7100
10800
12600

NOT TO SCALE

NOT INTENDED FOR CONSTRUCTION,
BIDDING OR PERMIT PURPOSES
DHURVA LAHON, P.E.
SERIAL NUMBER 102185

US 380 GOLD ALT AND
RAMPS
AVERAGE DAILY TRAFFIC
GOLD ALT BUILD VOLUMES

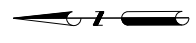
Kimley»Horn

0135-02-065,
ETC. SHEET 34 OF 61

LEGEND

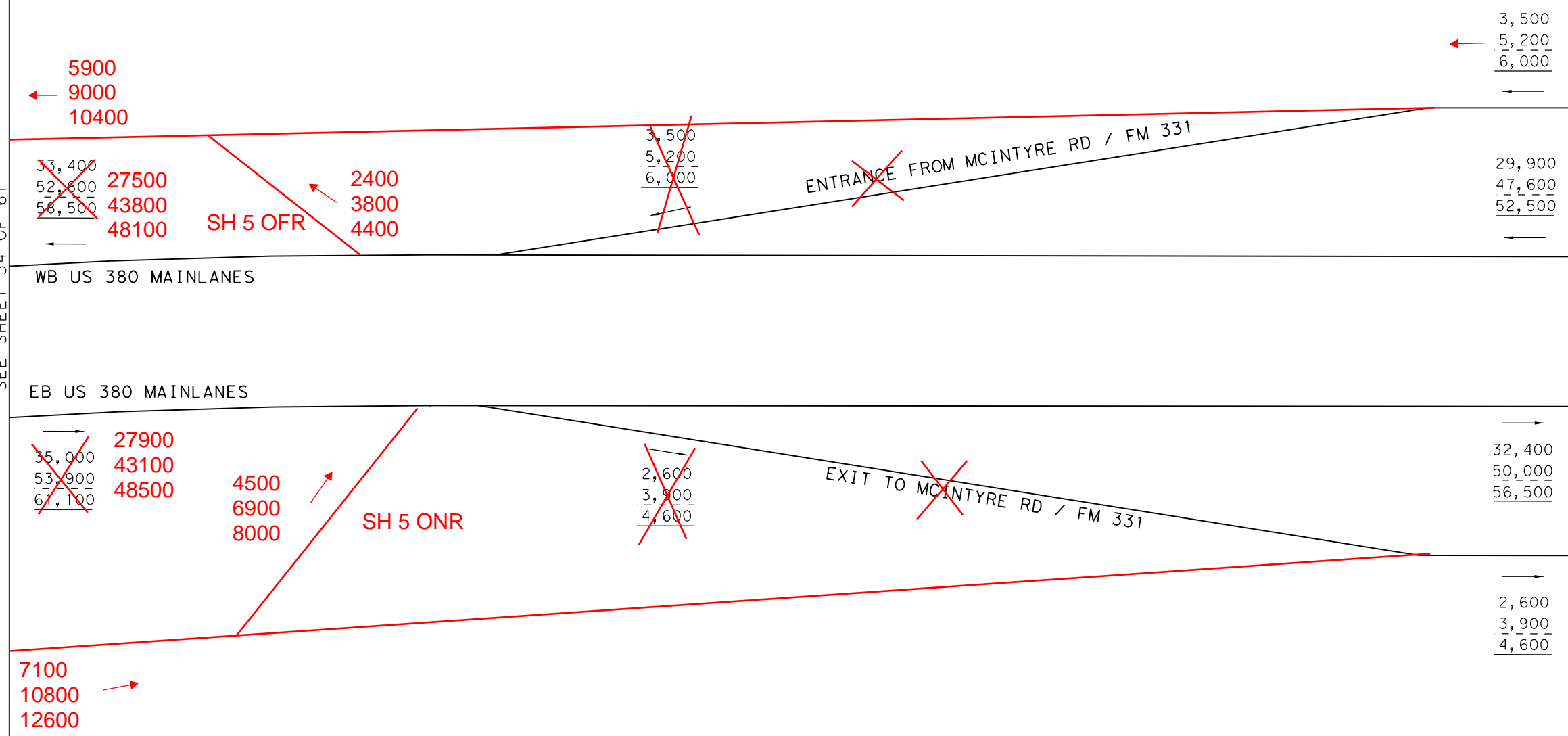
- XXXX- 2030 AVERAGE DAILY TRAFFIC VOLUMES
- XXXX- 2050 AVERAGE DAILY TRAFFIC VOLUMES
- XXXX- 2060 AVERAGE DAILY TRAFFIC VOLUMES

DATE: 7/13/2021
FILE: US380_GOLD_TRF_34.dgn



SEE SHEET 34 OF 61

SEE SHEET 36 OF 61



LEGEND

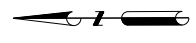
- XXXX- 2030 AVERAGE DAILY TRAFFIC VOLUMES
- XXXX- 2050 AVERAGE DAILY TRAFFIC VOLUMES
- XXXX- 2060 AVERAGE DAILY TRAFFIC VOLUMES

NOT TO SCALE

NOT INTENDED FOR CONSTRUCTION,
 BIDDING OR PERMIT PURPOSES
 DHRUVA LAHON, P.E.
 SERIAL NUMBER 102185

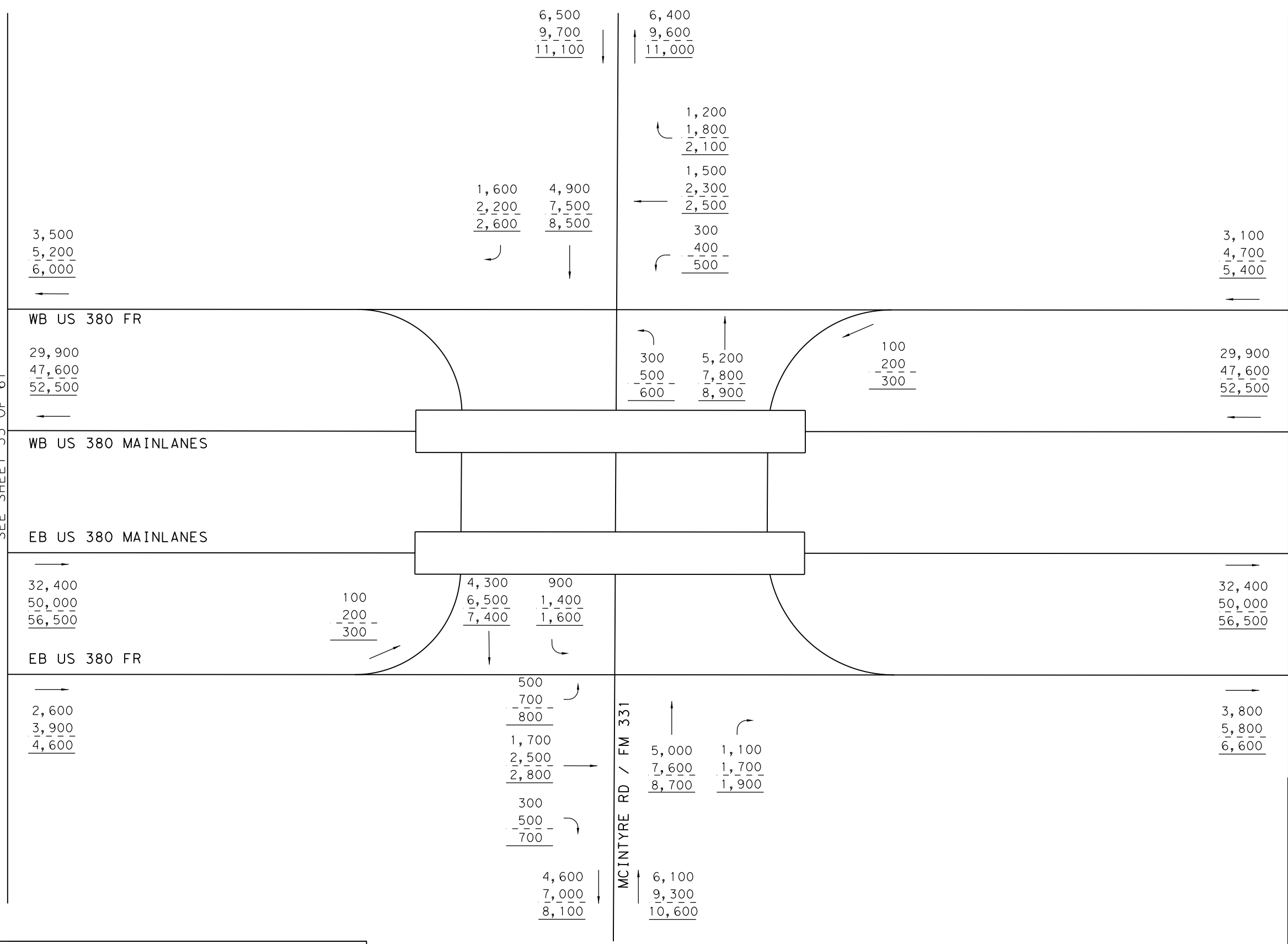
US 380 GOLD ALT AND
 RAMPS
 AVERAGE DAILY TRAFFIC
 GOLD ALT BUILD VOLUMES





SEE SHEET 35 OF 61

SEE SHEET 37 OF 61



LEGEND

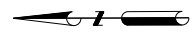
- XXXX** - 2030 AVERAGE DAILY TRAFFIC VOLUMES
- XXXX - 2050 AVERAGE DAILY TRAFFIC VOLUMES
- XXXX* - 2060 AVERAGE DAILY TRAFFIC VOLUMES

NOT TO SCALE

NOT INTENDED FOR CONSTRUCTION,
BIDDING OR PERMIT PURPOSES
DHURVA LAHON, P.E.
SERIAL NUMBER 102185

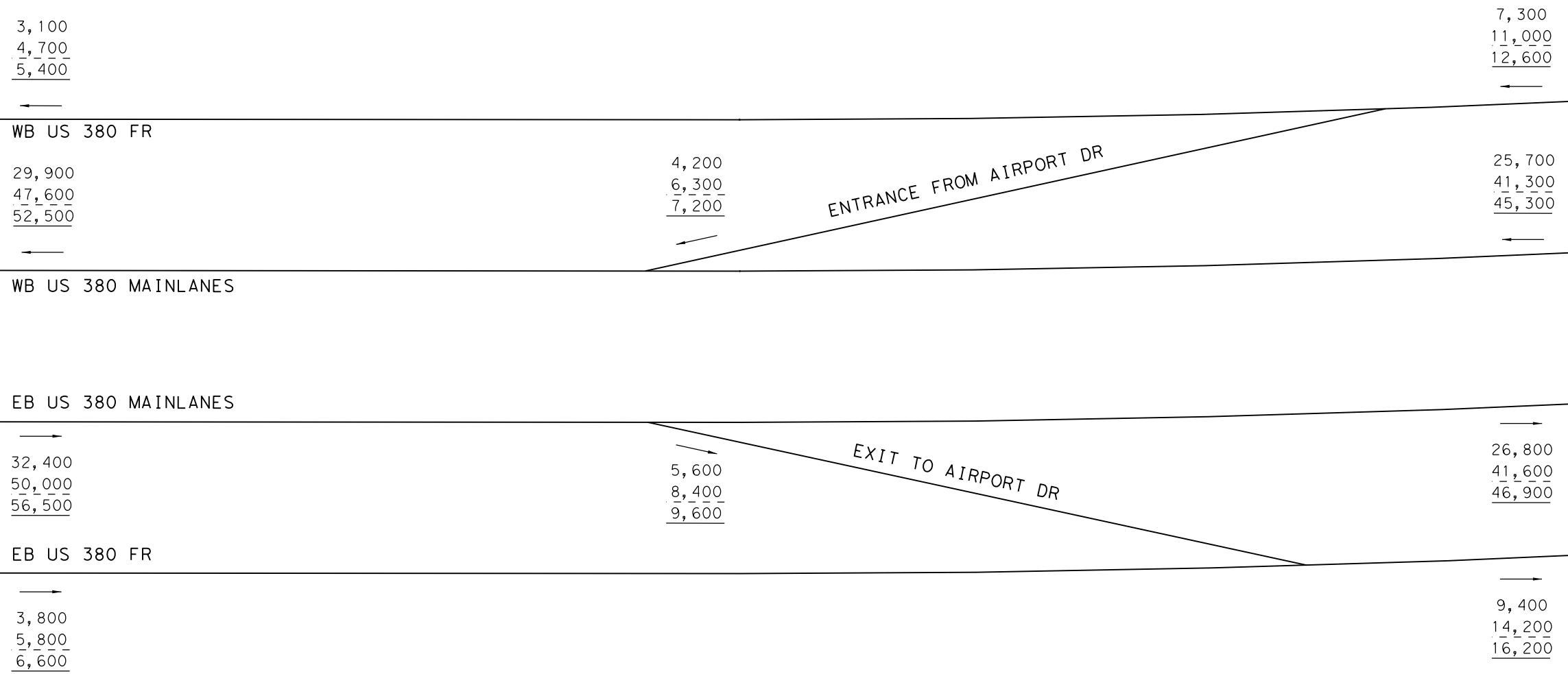
US 380 GOLD ALT AND
MCINTYRE RD/ CR 274
AVERAGE DAILY TRAFFIC
GOLD ALT BUILD VOLUMES





SEE SHEET 36 OF 61

SEE SHEET 38 OF 61



NOT TO SCALE

NOT INTENDED FOR CONSTRUCTION,
 BIDDING OR PERMIT PURPOSES
 DHRUVA LAHON, P.E.
 SERIAL NUMBER 102185

US 380 GOLD ALT AND
 RAMPS
 AVERAGE DAILY TRAFFIC
 GOLD ALT BUILD VOLUMES

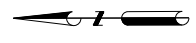


0135-02-065,
 ETC. SHEET 37 OF 61

LEGEND

- XXXX- 2030 AVERAGE DAILY TRAFFIC VOLUMES
- XXXX- 2050 AVERAGE DAILY TRAFFIC VOLUMES
- XXXX- 2060 AVERAGE DAILY TRAFFIC VOLUMES

DATE: 7/13/2021
 FILE: US380_GOLD_TRF_37.dgn



7,300
11,000
12,600

WB US 380 FR

25,700
41,300
45,300

WB US 380 MAINLANES

EB US 380 MAINLANES

26,800
41,600
46,900

EB US 380 FR

9,400
14,200
16,200

~~4,600~~
~~6,900~~
~~7,900~~
7300
11000
12600

~~2,700~~
~~4,100~~
~~4,700~~

25700
41300
45300

EXIT TO MCINTYRE RD / FM 331

ENTRANCE FROM MCINTYRE RD / FM 331

~~4,300~~
~~6,500~~
~~7,200~~
3400
4900
5700

~~31,100~~
~~47,900~~
~~54,100~~
30200
46500
52600

~~5,100~~
~~7,900~~
~~9,000~~
6000
9300
10500

SEE SHEET 37 OF 61

SEE SHEET 39 OF 61

NOT TO SCALE

NOT INTENDED FOR CONSTRUCTION,
BIDDING OR PERMIT PURPOSES
DHURVA LAHON, P.E.
SERIAL NUMBER 102185

US 380 GOLD ALT AND
RAMPS
AVERAGE DAILY TRAFFIC
GOLD ALT BUILD VOLUMES

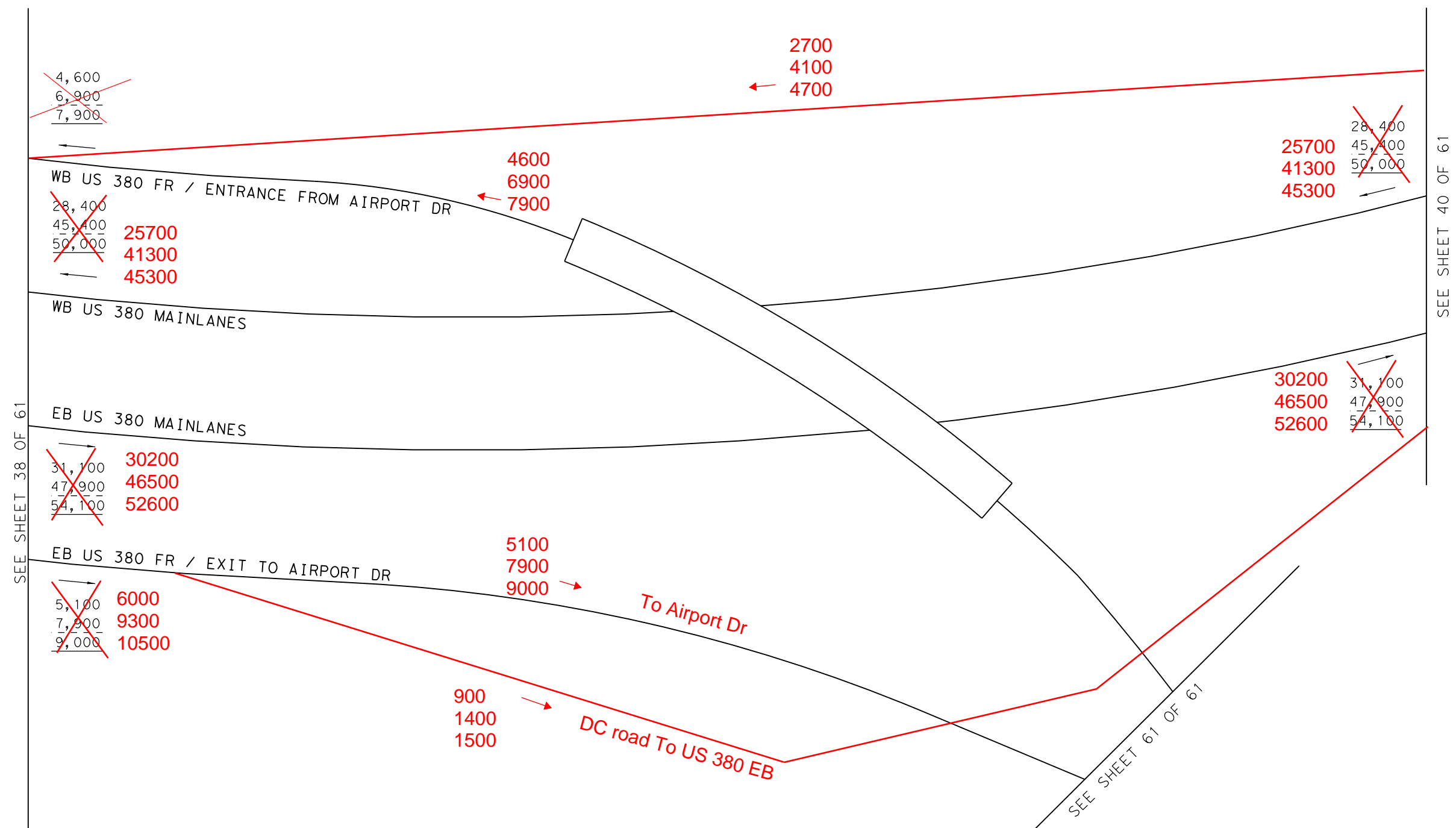
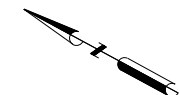
Kimley»Horn
F-928

0135-02-065,
ETC. SHEET 38 OF 61

LEGEND

- XXXX- 2030 AVERAGE DAILY TRAFFIC VOLUMES
- XXXX- 2050 AVERAGE DAILY TRAFFIC VOLUMES
- XXXX- 2060 AVERAGE DAILY TRAFFIC VOLUMES

DATE: 7/13/2021
FILE: US380_GOLD_TRF_38.dgn



SEE SHEET 38 OF 61

SEE SHEET 40 OF 61

SEE SHEET 61 OF 61

NOT TO SCALE

NOT INTENDED FOR CONSTRUCTION,
 BIDDING OR PERMIT PURPOSES
 DHRUVA LAHON, P.E.
 SERIAL NUMBER 102185

US 380 GOLD ALT AND
 RAMP
 AVERAGE DAILY TRAFFIC
 GOLD ALT BUILD VOLUMES

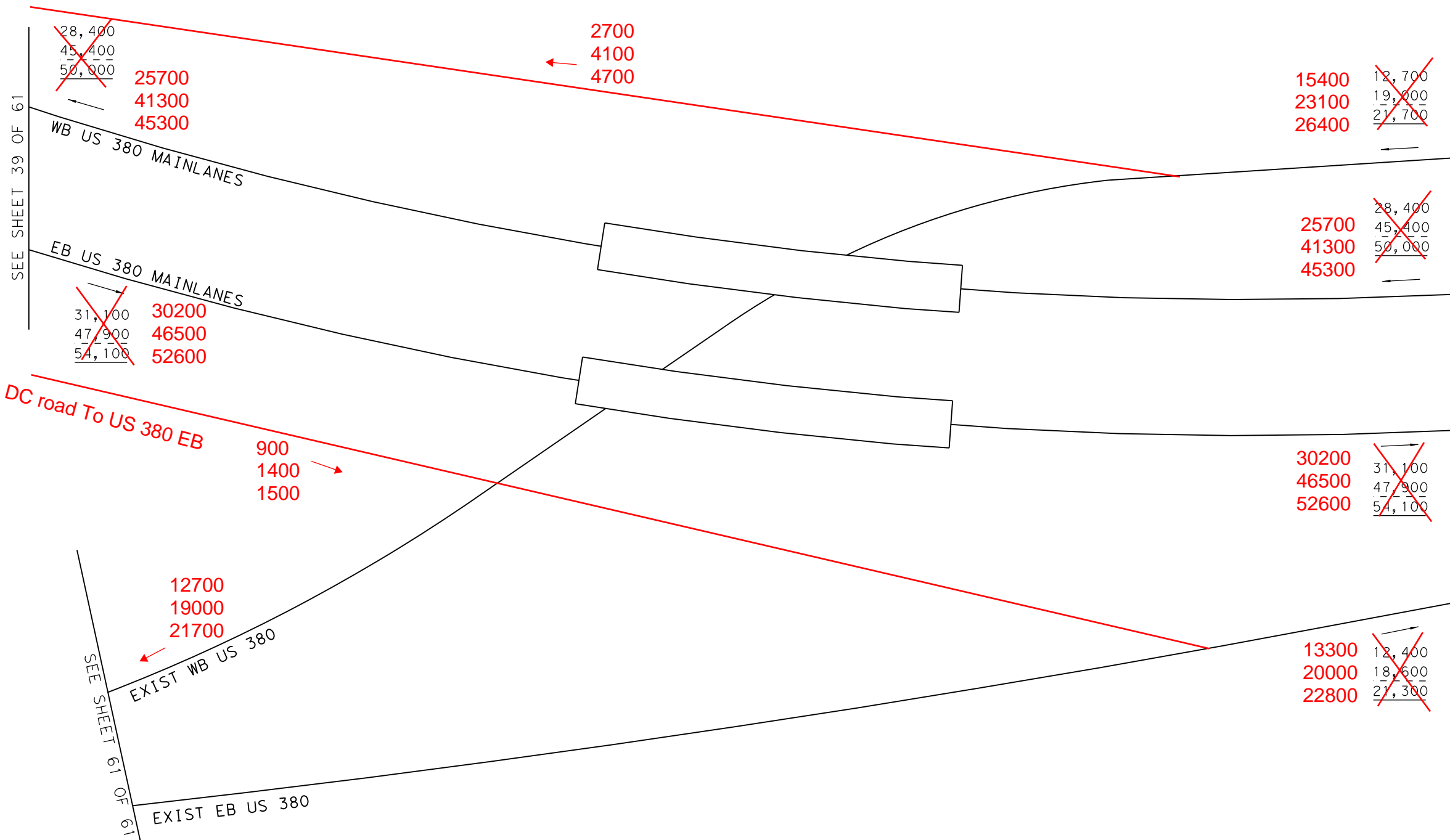
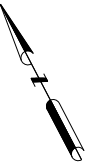


0135-02-065,
 ETC. SHEET 39 OF 61

LEGEND

- XXXX- 2030 AVERAGE DAILY TRAFFIC VOLUMES
- XXXX- 2050 AVERAGE DAILY TRAFFIC VOLUMES
- XXXX- 2060 AVERAGE DAILY TRAFFIC VOLUMES

DATE: 7/13/2021
 FILE: US380_GOLD_TRF_39.dgn



NOT TO SCALE

NOT INTENDED FOR CONSTRUCTION,
BIDDING OR PERMIT PURPOSES
DHURVA LAHON, P.E.
SERIAL NUMBER 102185

US 380 GOLD ALT AND
RAMPS
AVERAGE DAILY TRAFFIC
GOLD ALT BUILD VOLUMES

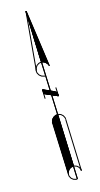


0135-02-065,
ETC. SHEET 40 OF 61

LEGEND

- XXXX- 2030 AVERAGE DAILY TRAFFIC VOLUMES
- XXXX- 2050 AVERAGE DAILY TRAFFIC VOLUMES
- XXXX- 2060 AVERAGE DAILY TRAFFIC VOLUMES

DATE: 7/13/2021
FILE: US380_GOLD_TRF_40.dgn



SEE SHEET 40 OF 61

SEE SHEET 42 OF 61

12,700	15400
19,000	23100
21,700	26400

20100	41,100
30600	64,100
34200	71,700

WB US 380 FR

28,400	25700
45,400	41300
50,000	45300

← **4700**
7500
7800

← **21000**
33800
37500

WB US 380 MAINLANES

EB US 380 MAINLANES

31,100	30200
47,900	46500
54,100	52600

4100 →
6200
7200

26100
40300 →
45400

EB US 380 FR

12,400	13300
18,600	20000
21,300	22800

17400	43,500
26200	66,500
30000	75,400

NOT TO SCALE

NOT INTENDED FOR CONSTRUCTION,
BIDDING OR PERMIT PURPOSES
DHURVA LAHON, P.E.
SERIAL NUMBER 102185

US 380 GOLD ALT AND
RAMPS
AVERAGE DAILY TRAFFIC
GOLD ALT BUILD VOLUMES

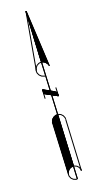
Kimley»Horn
F-928

0135-02-065,
ETC. SHEET 41 OF 61

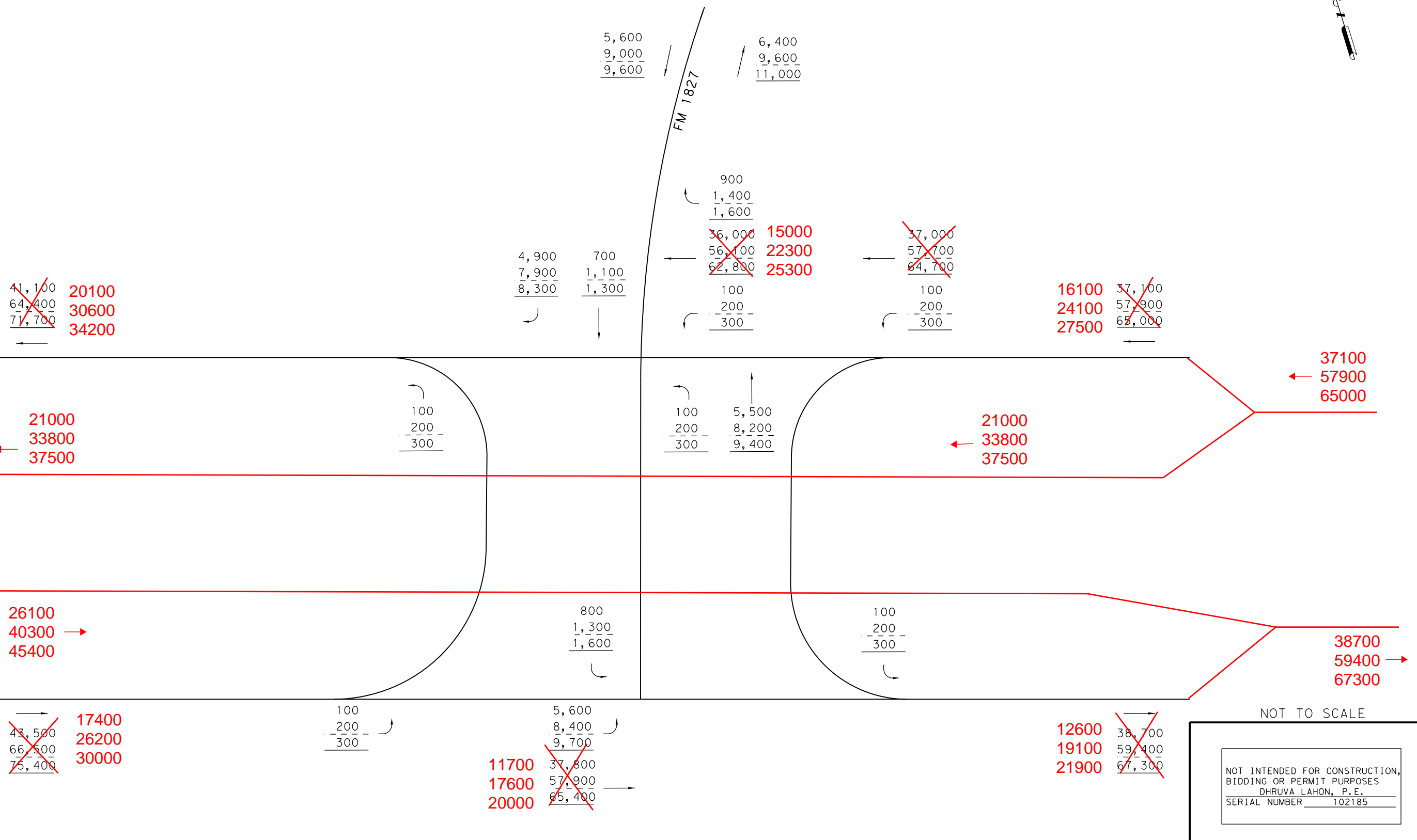
LEGEND

- XXXX- 2030 AVERAGE DAILY TRAFFIC VOLUMES
- XXXX- 2050 AVERAGE DAILY TRAFFIC VOLUMES
- XXXX- 2060 AVERAGE DAILY TRAFFIC VOLUMES

DATE: 7/13/2021
FILE: US380_GOLD_TRF_41.dgn



SEE SHEET 41 OF 61



~~41,100~~ 20100
~~64,400~~ 30600
~~71,700~~ 34200

4,900 700
~~7,900~~ 1,100
~~8,300~~ 1,300

5,600 6,400
~~9,000~~ 9,600
~~9,600~~ 11,000

900
~~1,400~~
~~1,600~~

~~36,000~~ 15000
~~56,400~~ 22300
~~62,800~~ 25300

~~37,000~~
~~57,400~~
~~64,700~~

16100 ~~37,100~~
24100 ~~57,900~~
27500 ~~67,000~~

37100
57900
65000

21000
33800
37500

21000
33800
37500

26100
40300 →
45400

38700
59400 →
67300

~~43,500~~ 17400
~~66,500~~ 26200
~~75,400~~ 30000

11700
17600
20000

12600 ~~38,700~~
19100 ~~59,400~~
21900 ~~67,300~~

NOT TO SCALE

NOT INTENDED FOR CONSTRUCTION,
BIDDING OR PERMIT PURPOSES
DHURVA LAHON, P.E.
SERIAL NUMBER 102185

US 380 GOLD ALT AND
NEW HOPE ROAD/ FM 1827
AVERAGE DAILY TRAFFIC
GOLD ALT BUILD VOLUMES

Kimley»Horn
F-928

0135-02-065,
ETC. SHEET 42 OF 61

LEGEND

- XXXX- 2030 AVERAGE DAILY TRAFFIC VOLUMES
- XXXX- 2050 AVERAGE DAILY TRAFFIC VOLUMES
- XXXX- 2060 AVERAGE DAILY TRAFFIC VOLUMES

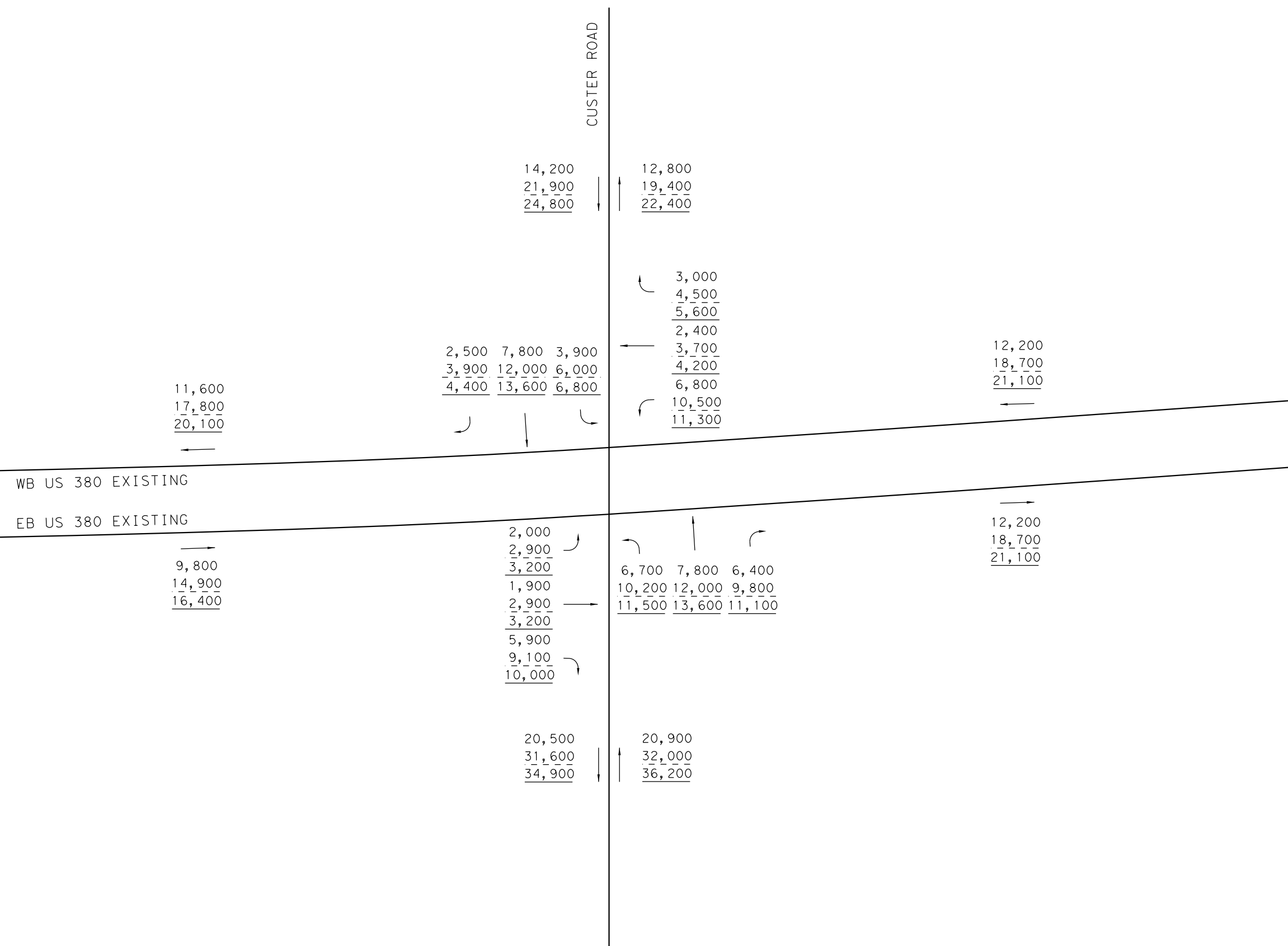
DATE: 7/13/2021
FILE: US380_GOLD_TRF_42.dgn



SEE SHEET 42 OF 61

SEE SHEET 44 OF 61

CUSTER ROAD



NOT TO SCALE

NOT INTENDED FOR CONSTRUCTION,
 BIDDING OR PERMIT PURPOSES
 DHRUVA LAHON, P.E.
 SERIAL NUMBER 102185

EXISTING US 380 AND
 CUSTER RD
 AVERAGE DAILY TRAFFIC

Kimley»Horn
F-928

0135-02-065,
 ETC. SHEET 43 OF 61

LEGEND

- XXXX- 2030 AVERAGE DAILY TRAFFIC VOLUMES
- XXXX- 2050 AVERAGE DAILY TRAFFIC VOLUMES
- XXXX- 2060 AVERAGE DAILY TRAFFIC VOLUMES

DATE: 7/13/2021
 FILE: US380_GOLD_TRF_43.dgn



SEE SHEET 43 OF 61

SEE SHEET 45 OF 61



NOT TO SCALE

NOT INTENDED FOR CONSTRUCTION,
 BIDDING OR PERMIT PURPOSES
 DHRUVA LAHON, P.E.
 SERIAL NUMBER 102185

EXISTING US 380 AND
 STONEBRIDGE DR
 AVERAGE DAILY TRAFFIC

Kimley»Horn
F-928

0135-02-065,
 ETC. SHEET 44 OF 61

LEGEND

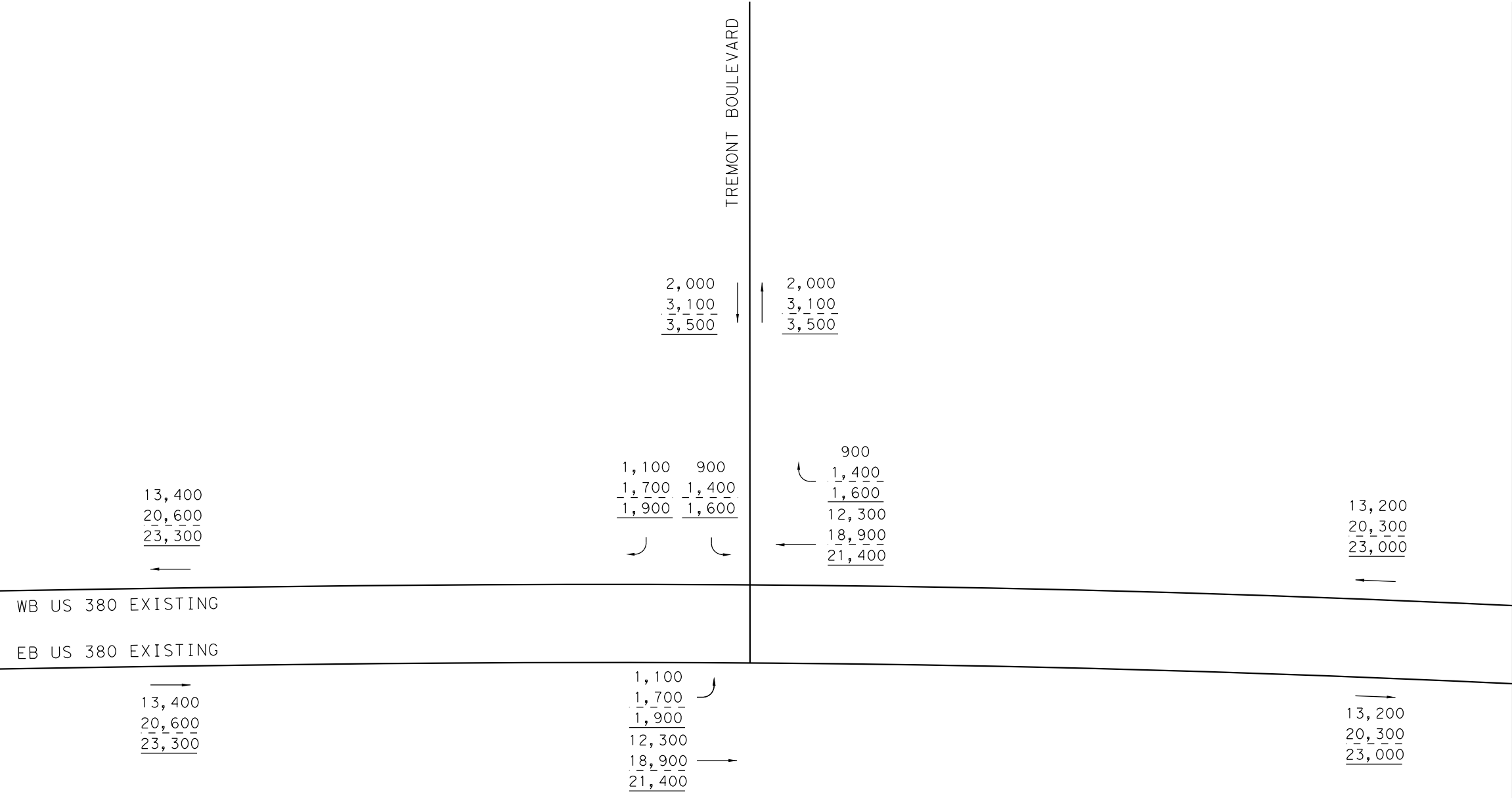
- XXXX- 2030 AVERAGE DAILY TRAFFIC VOLUMES
- XX- 2050 AVERAGE DAILY TRAFFIC VOLUMES
- XX- 2060 AVERAGE DAILY TRAFFIC VOLUMES

DATE: 7/13/2021
 FILE: US380_GOLD_TRF_44.dgn



SEE SHEET 44 OF 61

SEE SHEET 46 OF 61



NOT TO SCALE

NOT INTENDED FOR CONSTRUCTION,
 BIDDING OR PERMIT PURPOSES
 DHRUVA LAHON, P.E.
 SERIAL NUMBER 102185

EXISTING US 380 AND
 TREMONT BLVD
 AVERAGE DAILY TRAFFIC

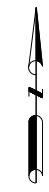
Kimley»Horn
F-928

0135-02-065,
 ETC. SHEET 45 OF 61

LEGEND

- XXXX- 2030 AVERAGE DAILY TRAFFIC VOLUMES
- XXXX- 2050 AVERAGE DAILY TRAFFIC VOLUMES
- XXXX- 2060 AVERAGE DAILY TRAFFIC VOLUMES

DATE: 7/13/2021
 FILE: US380_GOLD_TRF_45.dgn



SEE SHEET 45 OF 61

SEE SHEET 47 OF 61

13,200
20,300
22,900

11,300
17,300
19,600
4,400
6,800
7,700

15,700
24,100
27,300

WB US 380 EXISTING
EB US 380 EXISTING

13,200
20,300
22,900

10,600
16,300
18,300
2,600
4,000
4,600

1,900 4,700
3,000 7,300
3,300 8,200

15,300
23,600
26,500

7,000
10,800
12,300

6,600
10,300
11,500

RIDGE ROAD

NOT TO SCALE

NOT INTENDED FOR CONSTRUCTION,
BIDDING OR PERMIT PURPOSES
DHURVA LAHON, P.E.
SERIAL NUMBER 102185

EXISTING US 380 AND
RIDGE RD
AVERAGE DAILY TRAFFIC

Kimley»Horn
F-928

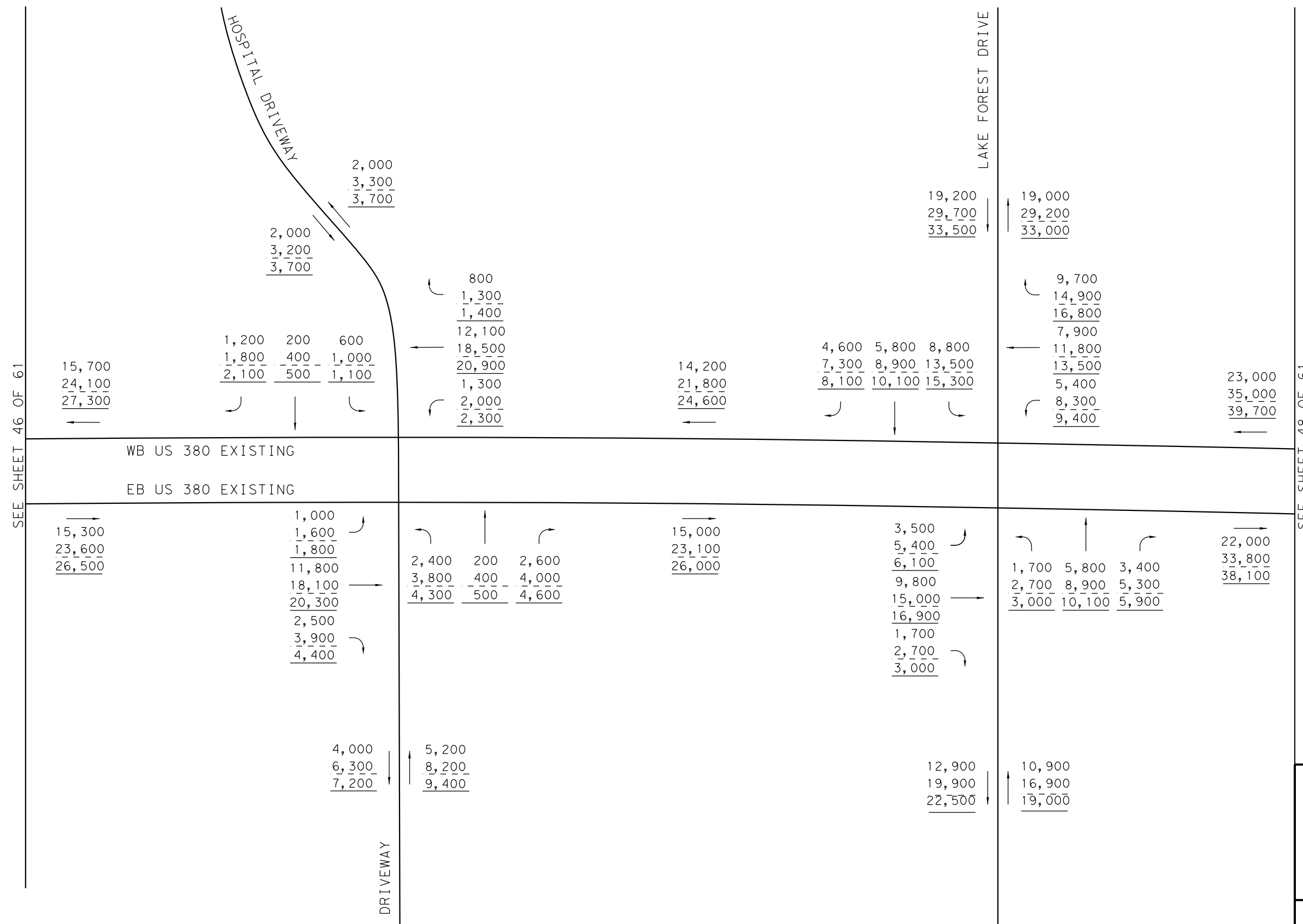
0135-02-065,
ETC.

SHEET 46 OF 61

LEGEND

- XXXX- 2030 AVERAGE DAILY TRAFFIC VOLUMES
- XXXX- 2050 AVERAGE DAILY TRAFFIC VOLUMES
- XXXX- 2060 AVERAGE DAILY TRAFFIC VOLUMES

DATE: 7/13/2021
FILE: US380_GOLD_TRF_46.dgn



SEE SHEET 46 OF 61

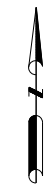
SEE SHEET 48 OF 61

NOT TO SCALE

NOT INTENDED FOR CONSTRUCTION,
 BIDDING OR PERMIT PURPOSES
 DHRUVA LAHON, P.E.
 SERIAL NUMBER 102185

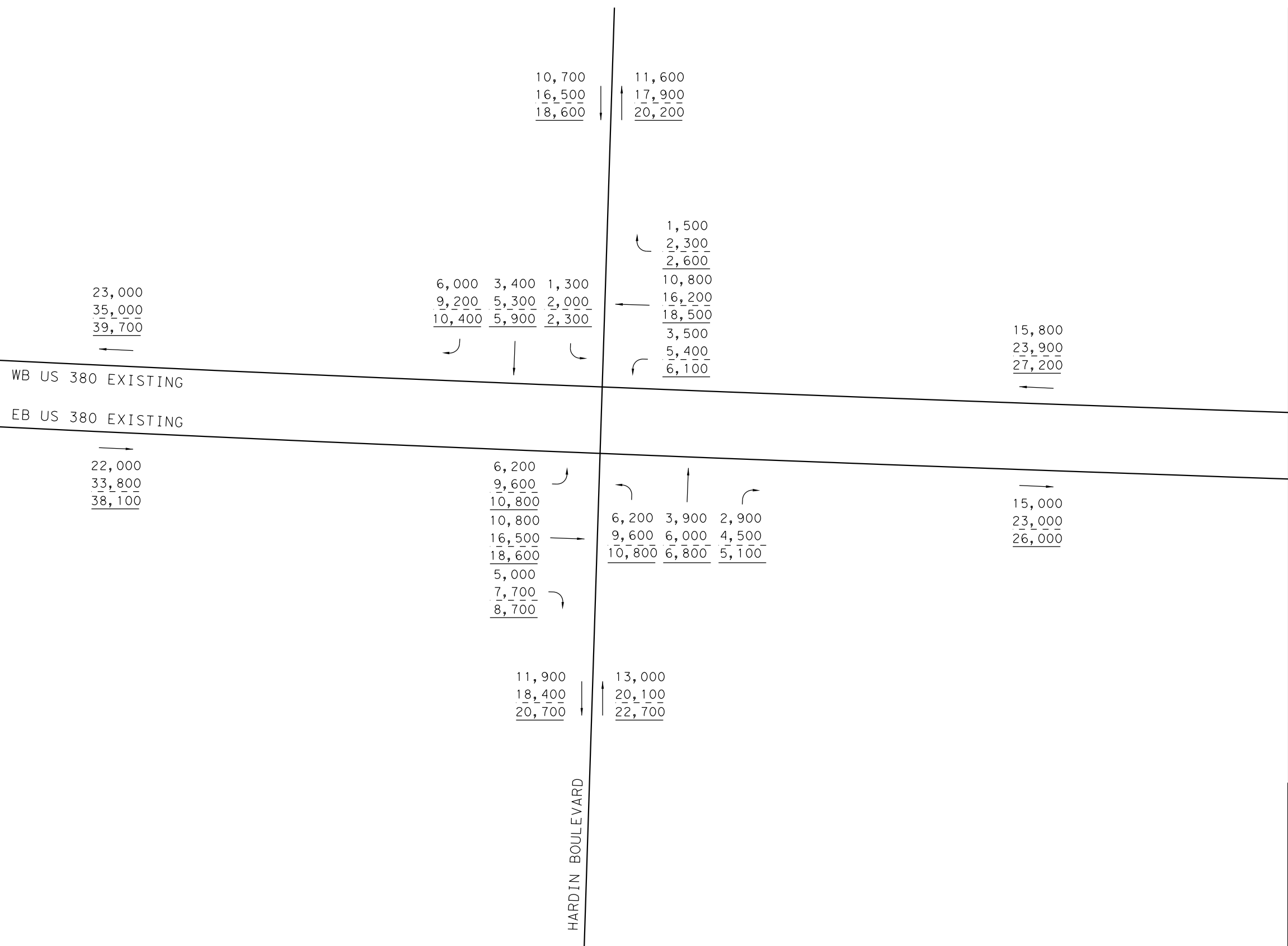
EXISTING US 380 AND
 LAKE FOREST DR
 AVERAGE DAILY TRAFFIC

Kimley»Horn
F-928



SEE SHEET 47 OF 61

SEE SHEET 49 OF 61



WB US 380 EXISTING
 EB US 380 EXISTING

HARDIN BOULEVARD

NOT TO SCALE

NOT INTENDED FOR CONSTRUCTION,
 BIDDING OR PERMIT PURPOSES
 DHRUVA LAHON, P.E.
 SERIAL NUMBER 102185

EXISTING US 380 AND
 HARDIN BLVD
 AVERAGE DAILY TRAFFIC

Kimley»Horn
F-928

0135-02-065,
 ETC. SHEET 48 OF 61

LEGEND

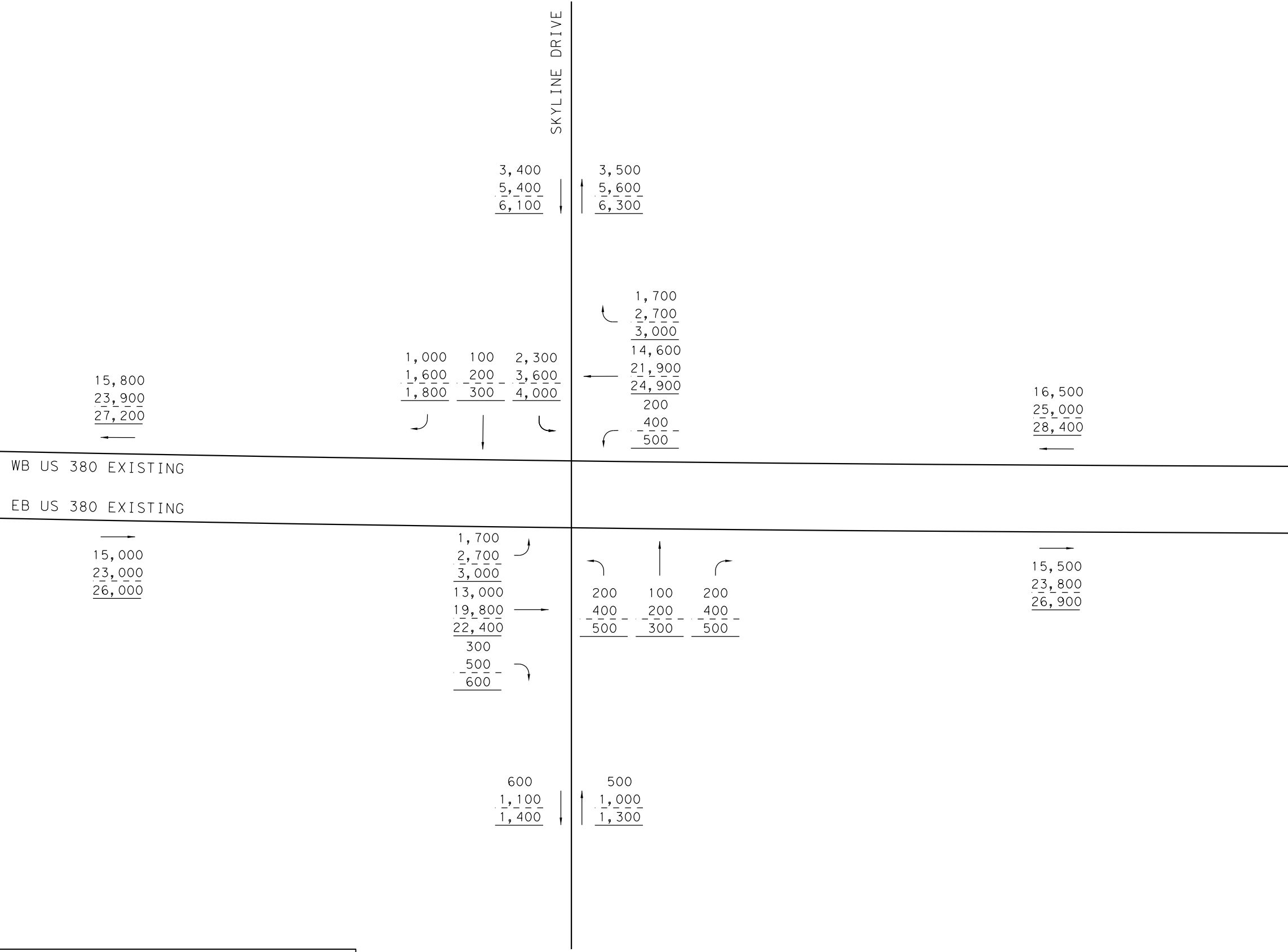
- XXXX- 2030 AVERAGE DAILY TRAFFIC VOLUMES
- XXXX- 2050 AVERAGE DAILY TRAFFIC VOLUMES
- XXXX- 2060 AVERAGE DAILY TRAFFIC VOLUMES

DATE: 7/13/2021
 FILE: US380_GOLD_TRF_48.dgn



SEE SHEET 48 OF 61

SEE SHEET 50 OF 61



NOT TO SCALE

NOT INTENDED FOR CONSTRUCTION,
 BIDDING OR PERMIT PURPOSES
 DHRUVA LAHON, P.E.
 SERIAL NUMBER 102185

EXISTING US 380 AND
 SKYLINE DR
 AVERAGE DAILY TRAFFIC

Kimley»Horn
F-928

0135-02-065,
 ETC. SHEET 49 OF 61

LEGEND

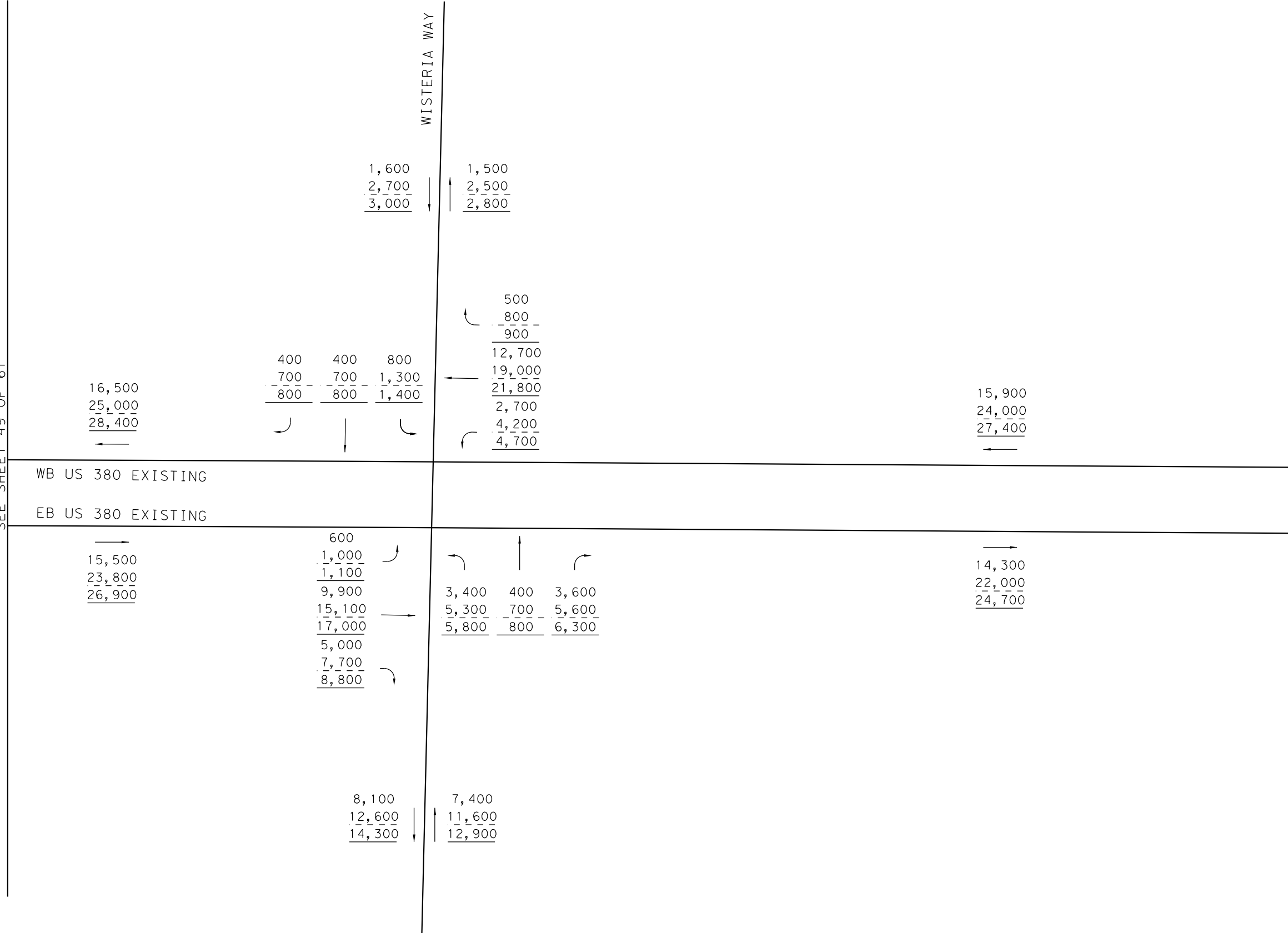
- XXXX- 2030 AVERAGE DAILY TRAFFIC VOLUMES
- XXXX- 2050 AVERAGE DAILY TRAFFIC VOLUMES
- XXXX- 2060 AVERAGE DAILY TRAFFIC VOLUMES

DATE: 7/13/2021
 FILE: US380_GOLD_TRF_49.dgn



SEE SHEET 49 OF 61

SEE SHEET 51 OF 61



WB US 380 EXISTING
EB US 380 EXISTING

NOT TO SCALE

NOT INTENDED FOR CONSTRUCTION,
BIDDING OR PERMIT PURPOSES
DHURVA LAHON, P.E.
SERIAL NUMBER 102185

EXISTING US 380 AND
WISTERIA WAY
AVERAGE DAILY TRAFFIC

Kimley»Horn
F-928

0135-02-065,
ETC. SHEET 50 OF 61

LEGEND

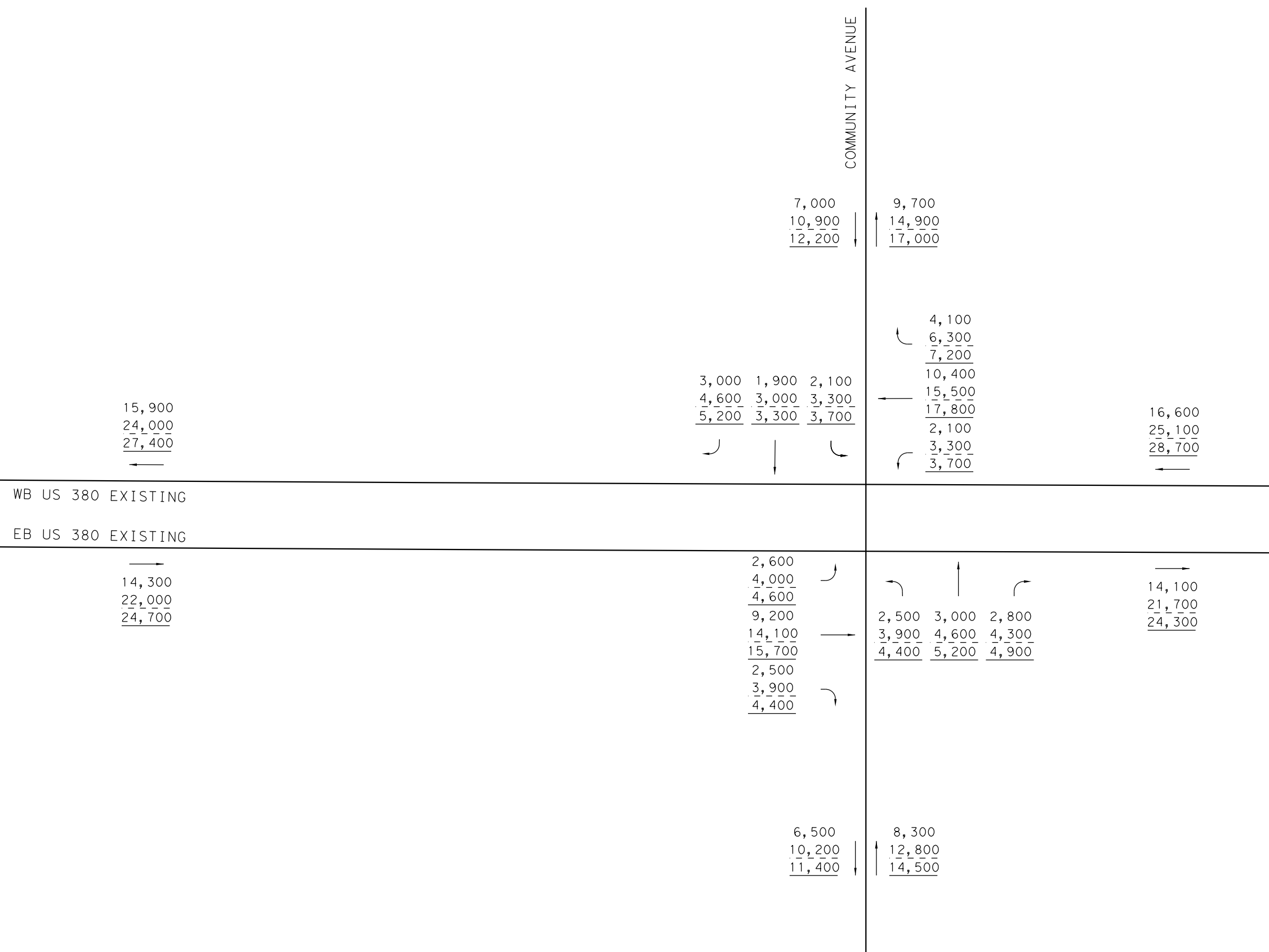
- XXXX- 2030 AVERAGE DAILY TRAFFIC VOLUMES
- XXXX- 2050 AVERAGE DAILY TRAFFIC VOLUMES
- XXXX- 2060 AVERAGE DAILY TRAFFIC VOLUMES

DATE: 7/13/2021
FILE: US380_GOLD_TRF_50.dgn



SEE SHEET 50 OF 61

SEE SHEET 52 OF 61



NOT TO SCALE

NOT INTENDED FOR CONSTRUCTION,
 BIDDING OR PERMIT PURPOSES
 DHRUVA LAHON, P.E.
 SERIAL NUMBER 102185

EXISTING US 380 AND
COMMUNITY AVE
AVERAGE DAILY TRAFFIC

Kimley»Horn
F-928

0135-02-065,
ETC. SHEET 51 OF 61

LEGEND

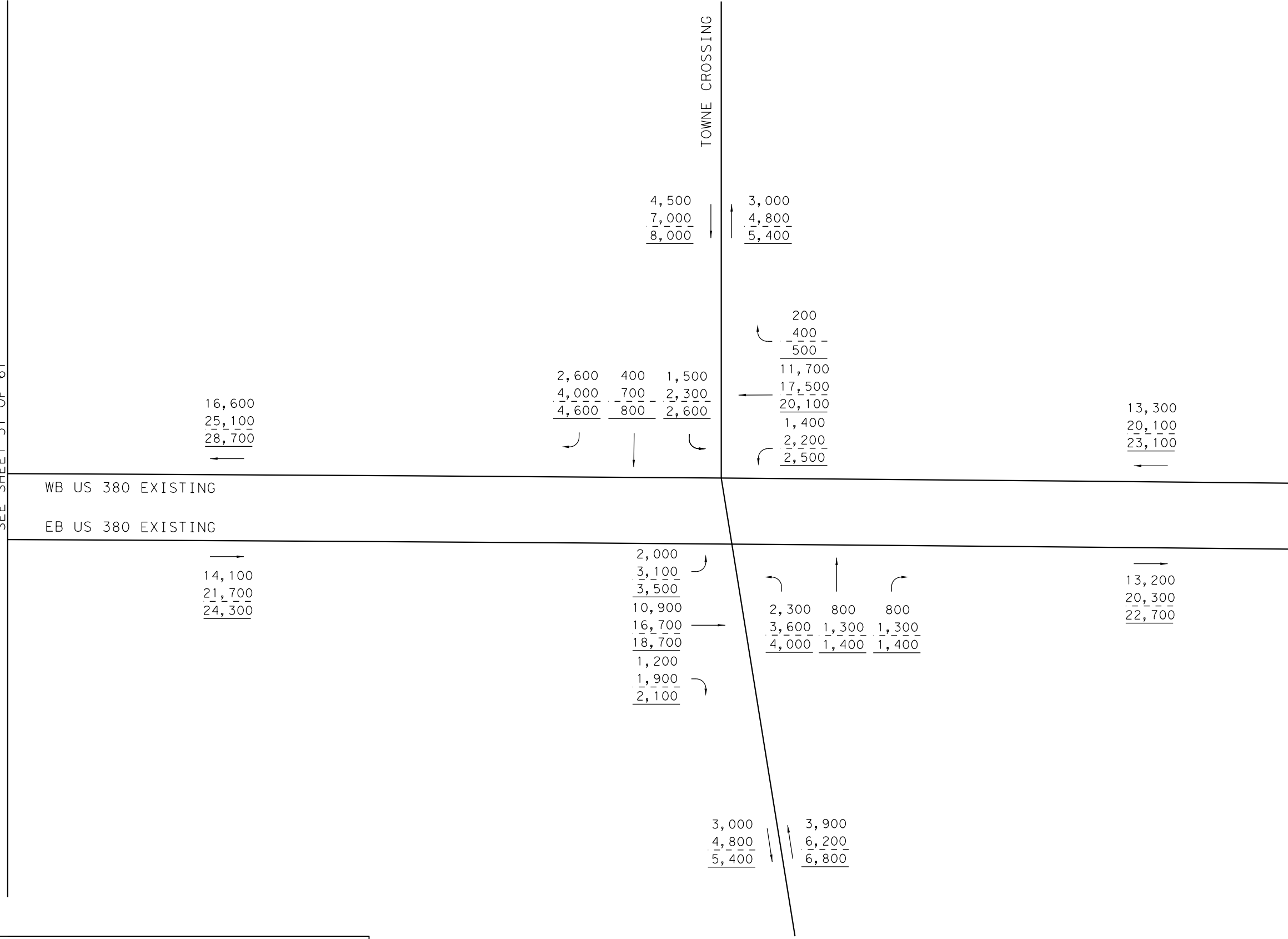
- XXXX- 2030 AVERAGE DAILY TRAFFIC VOLUMES
- XXXX- 2050 AVERAGE DAILY TRAFFIC VOLUMES
- XXXX- 2060 AVERAGE DAILY TRAFFIC VOLUMES

DATE: 7/13/2021
FILE: US380_GOLD_TRF_51.dgn



SEE SHEET 51 OF 61

SEE SHEET 53 OF 61



NOT TO SCALE

NOT INTENDED FOR CONSTRUCTION,
 BIDDING OR PERMIT PURPOSES
 DHRUVA LAHON, P.E.
 SERIAL NUMBER 102185

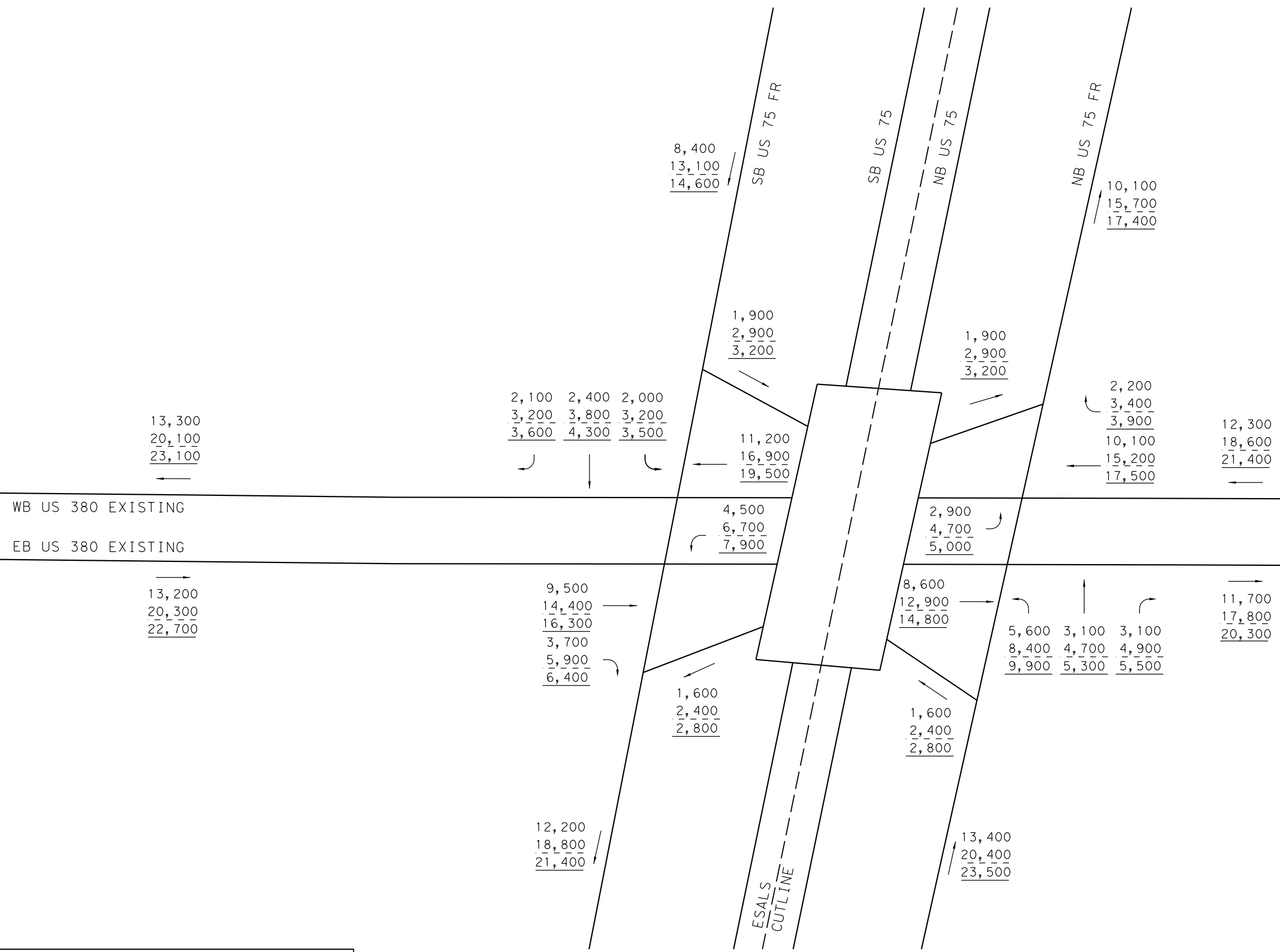
EXISTING US 380 AND
 TOWNE CROSSING
 AVERAGE DAILY TRAFFIC





SEE SHEET 52 OF 61

SEE SHEET 54 OF 61



NOT TO SCALE

NOT INTENDED FOR CONSTRUCTION,
 BIDDING OR PERMIT PURPOSES
 DHRUVA LAHON, P.E.
 SERIAL NUMBER 102185

EXISTING US 380 AND
 US 75
 AVERAGE DAILY TRAFFIC

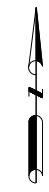
Kimley»Horn
F-928

0135-02-065,
 ETC. SHEET 53 OF 61

LEGEND

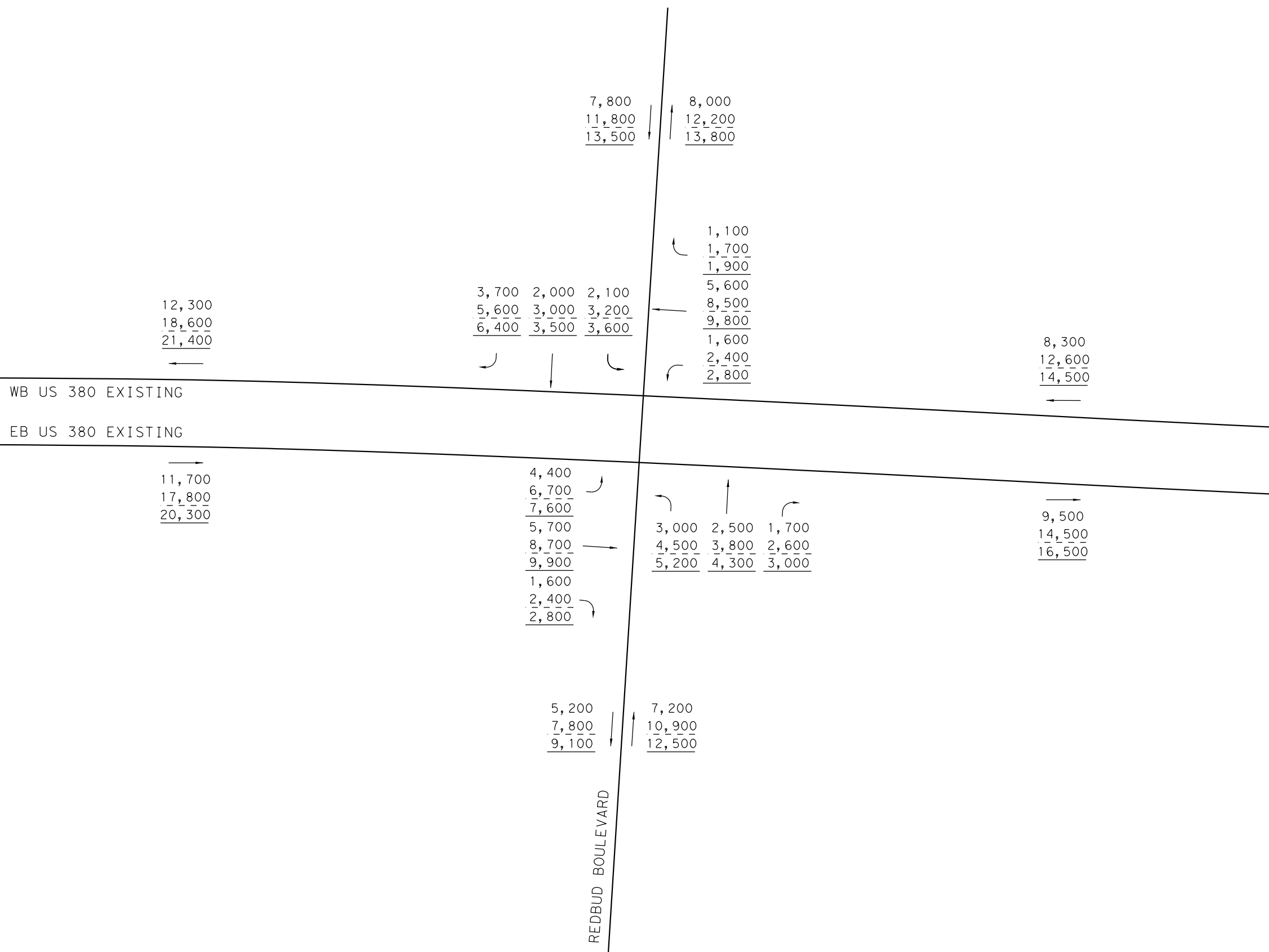
- XXXX- 2030 AVERAGE DAILY TRAFFIC VOLUMES
- XXXX- 2050 AVERAGE DAILY TRAFFIC VOLUMES
- XXXX- 2060 AVERAGE DAILY TRAFFIC VOLUMES

DATE: 7/13/2021
 FILE: US380_GOLD_TRF_53.dgn



SEE SHEET 53 OF 61

SEE SHEET 55 OF 61



WB US 380 EXISTING
EB US 380 EXISTING

REDBUD BOULEVARD

NOT TO SCALE

NOT INTENDED FOR CONSTRUCTION,
BIDDING OR PERMIT PURPOSES
DHURVA LAHON, P.E.
SERIAL NUMBER 102185

EXISTING US 380 AND
REDBUD BLVD
AVERAGE DAILY TRAFFIC

Kimley»Horn
F-928

0135-02-065,
ETC. SHEET 54 OF 61

LEGEND

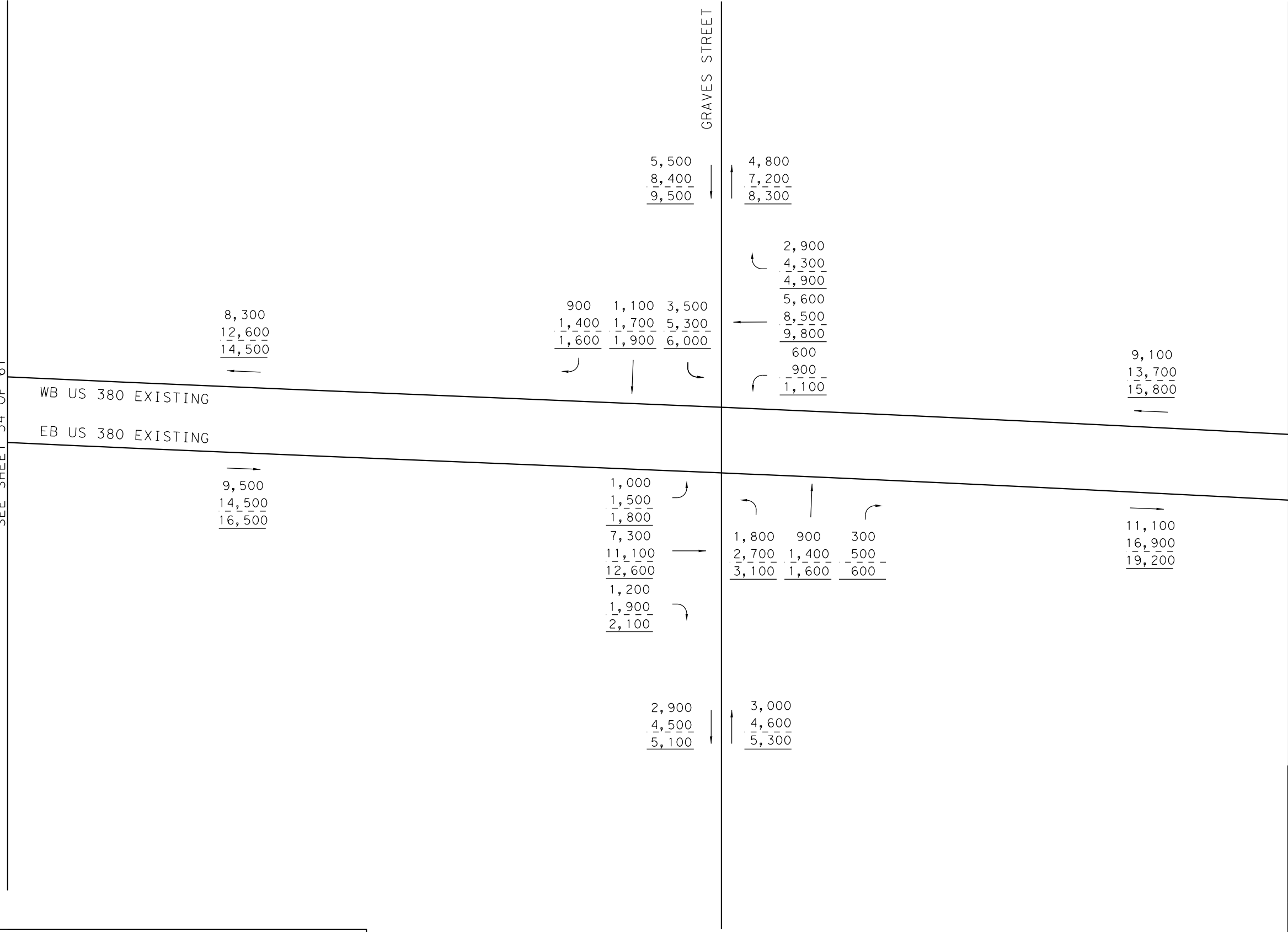
- XXXX- 2030 AVERAGE DAILY TRAFFIC VOLUMES
- XXXX- 2050 AVERAGE DAILY TRAFFIC VOLUMES
- XXXX- 2060 AVERAGE DAILY TRAFFIC VOLUMES

DATE: 7/13/2021
FILE: US380_GOLD_TRF_54.dgn



SEE SHEET 54 OF 61

SEE SHEET 56 OF 61



LEGEND

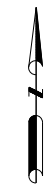
- XXXX- 2030 AVERAGE DAILY TRAFFIC VOLUMES
- XXXX- 2050 AVERAGE DAILY TRAFFIC VOLUMES
- XXXX- 2060 AVERAGE DAILY TRAFFIC VOLUMES

NOT TO SCALE

NOT INTENDED FOR CONSTRUCTION,
BIDDING OR PERMIT PURPOSES
DHURVA LAHON, P.E.
SERIAL NUMBER 102185

EXISTING US 380 AND
GRAVES ST
AVERAGE DAILY TRAFFIC





SEE SHEET 55 OF 61

SEE SHEET 57 OF 61

WB US 380 EXISTING

EB US 380 EXISTING

WADDILL STREET

9,100
13,700
15,800

200 200 600
300 300 900
400 400 1,100

1,000 600
1,500 900
1,900 1,200

200
300
400
8,200
12,300
14,100
900
1,400
1,600

9,300
14,000
16,100

11,100
16,900
19,200

200
300
400
9,800
14,900
16,900
1,100
1,700
1,900

700 200 1,300
1,100 300 2,000
1,300 400 2,300

11,700
17,800
20,300

2,200 2,200
3,400 3,400
3,900 4,000

NOT TO SCALE

NOT INTENDED FOR CONSTRUCTION,
BIDDING OR PERMIT PURPOSES
DHURVA LAHON, P.E.
SERIAL NUMBER 102185

EXISTING US 380 AND
WADDILL ST
AVERAGE DAILY TRAFFIC

Kimley»Horn
F-928

0135-02-065,
ETC. SHEET 56 OF 61

LEGEND

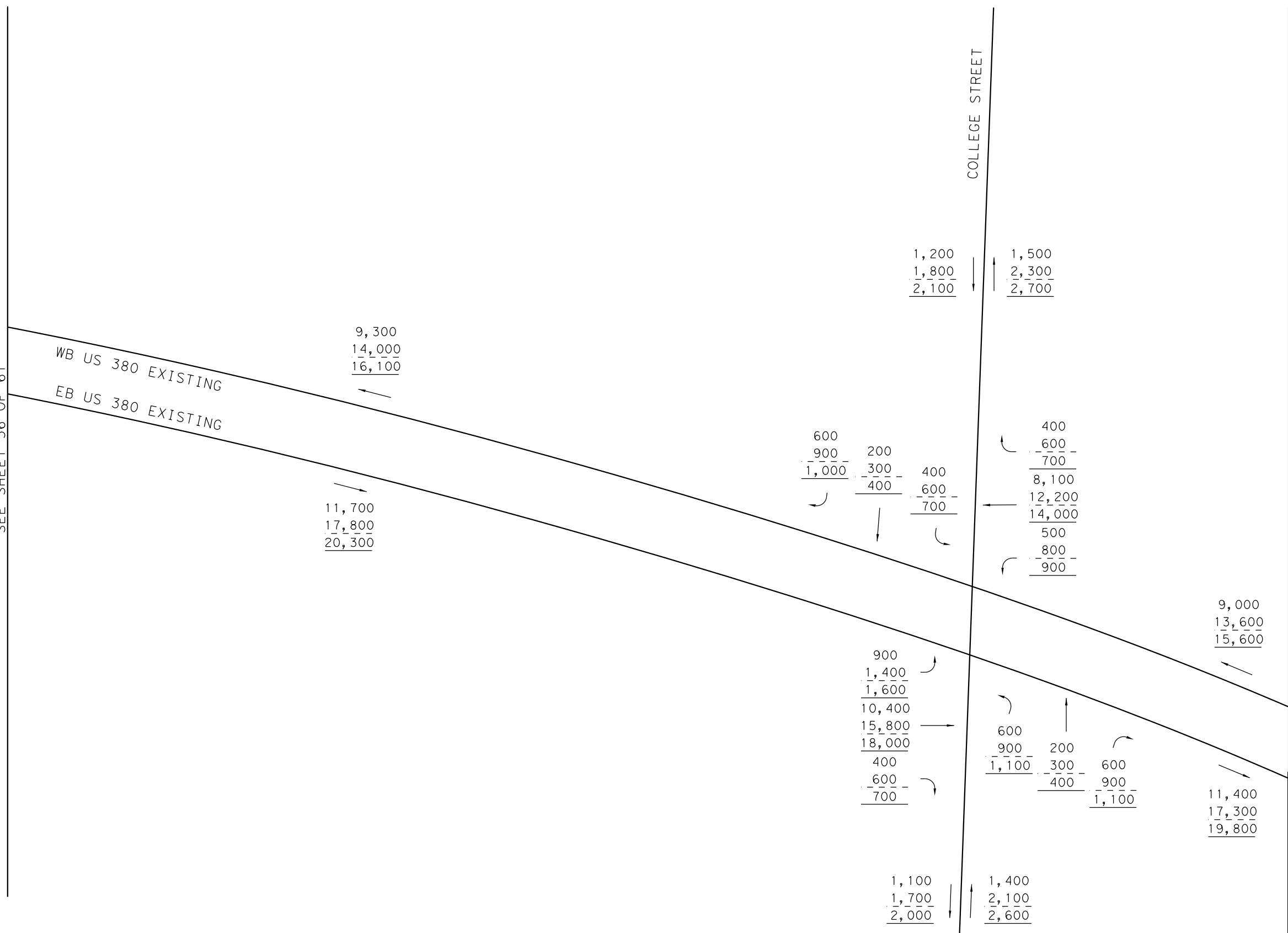
- XXXX- 2030 AVERAGE DAILY TRAFFIC VOLUMES
- XXXX- 2050 AVERAGE DAILY TRAFFIC VOLUMES
- XXXX- 2060 AVERAGE DAILY TRAFFIC VOLUMES

DATE: 7/13/2021
FILE: US380_GOLD_TRF_56.dgn



SEE SHEET 56 OF 61

SEE SHEET 58 OF 61



LEGEND

- XXXX- 2030 AVERAGE DAILY TRAFFIC VOLUMES
- XXXX- 2050 AVERAGE DAILY TRAFFIC VOLUMES
- XXXX- 2060 AVERAGE DAILY TRAFFIC VOLUMES

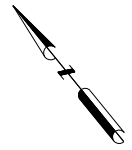
NOT TO SCALE

NOT INTENDED FOR CONSTRUCTION,
 BIDDING OR PERMIT PURPOSES
 DHRUVA LAHON, P.E.
 SERIAL NUMBER 102185

EXISTING US 380 AND
 COLLEGE ST
 AVERAGE DAILY TRAFFIC



DATE: 7/13/2021
 FILE: US380_GOLD_TRF_57.dgn



SEE SHEET 57 OF 61

SEE SHEET 59 OF 61

CHURCH STREET

9,000
13,600
 15,600
 ←
 WB US 380 EXISTING
 EB US 380 EXISTING
 →
 11,400
17,300
 19,800

2,600
4,000
 4,500

2,300
3,500
 4,300

900
1,400
 1,800

7,100
10,700
 12,300

1,500 400 700
2,300 600 1,100
 2,600 700 1,200

500
800
 900

8,500
12,900
 15,000

1,200
1,800
 2,100

400 200 400
600 300 600
 700 400 700

9,800
14,900
 17,000

400
600
 700

10,900
16,600
 18,900

1,300
2,000
 2,300

1,000
1,500
 1,800

NOT TO SCALE

NOT INTENDED FOR CONSTRUCTION,
 BIDDING OR PERMIT PURPOSES
 DHRUVA LAHON, P.E.
 SERIAL NUMBER 102185

EXISTING US 380 AND
 CHURCH ST
 AVERAGE DAILY TRAFFIC

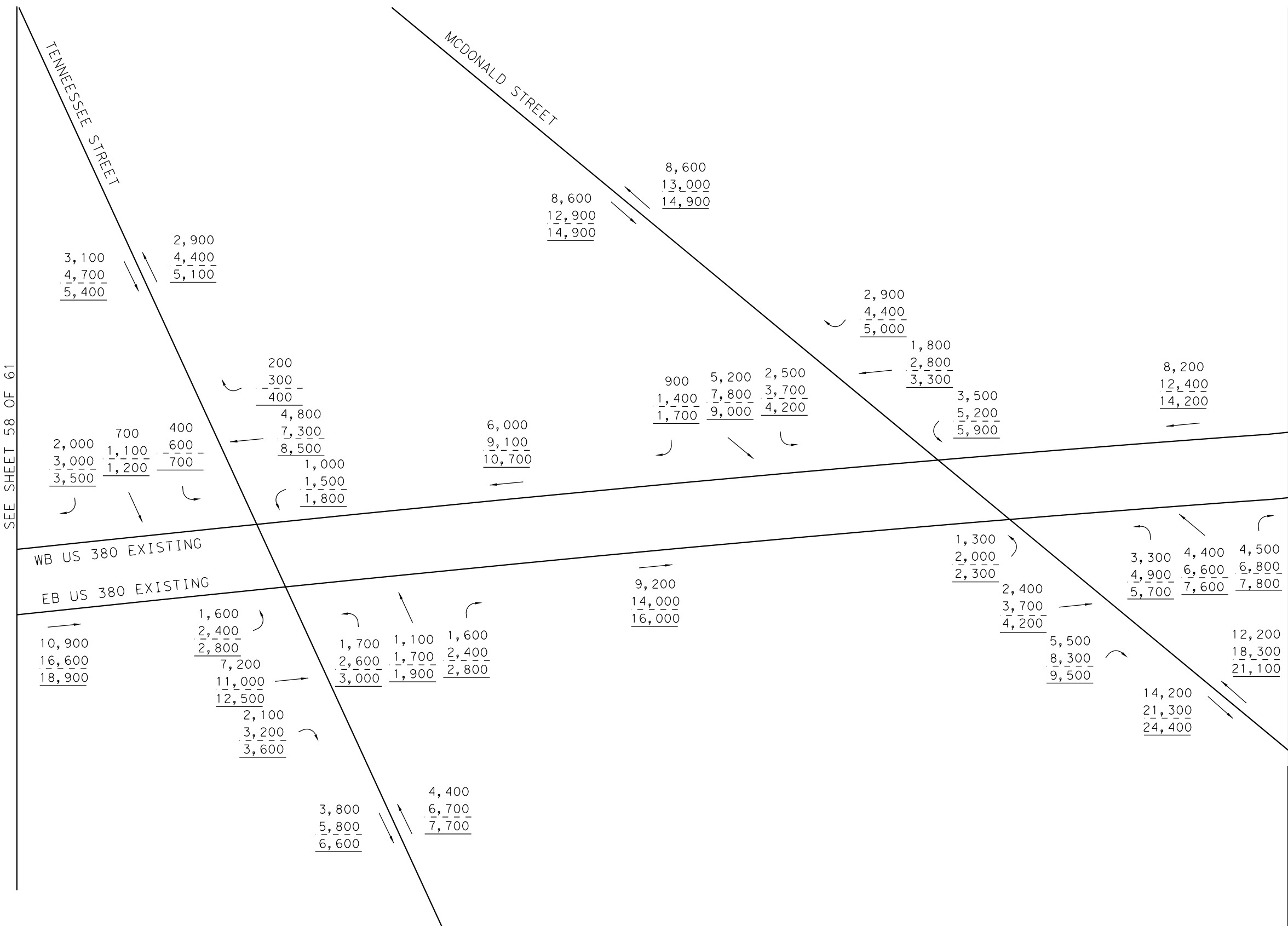
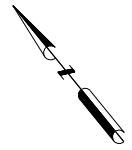
Kimley»Horn
F-928

0135-02-065,
 ETC. SHEET 58 OF 61

LEGEND

- XXXX- 2030 AVERAGE DAILY TRAFFIC VOLUMES
- XXXX- 2050 AVERAGE DAILY TRAFFIC VOLUMES
- XXXX- 2060 AVERAGE DAILY TRAFFIC VOLUMES

DATE: 7/13/2021
 FILE: US380_GOLD_TRF_58.dgn



SEE SHEET 58 OF 61

SEE SHEET 60 OF 61

WB US 380 EXISTING
EB US 380 EXISTING

NOT TO SCALE

NOT INTENDED FOR CONSTRUCTION,
BIDDING OR PERMIT PURPOSES
DHURVA LAHON, P.E.
SERIAL NUMBER 102185

EXISTING US 380 AND
MCDONALD ST
AVERAGE DAILY TRAFFIC

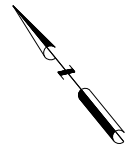
Kimley»Horn
F-928

0135-02-065,
ETC. SHEET 59 OF 61

LEGEND

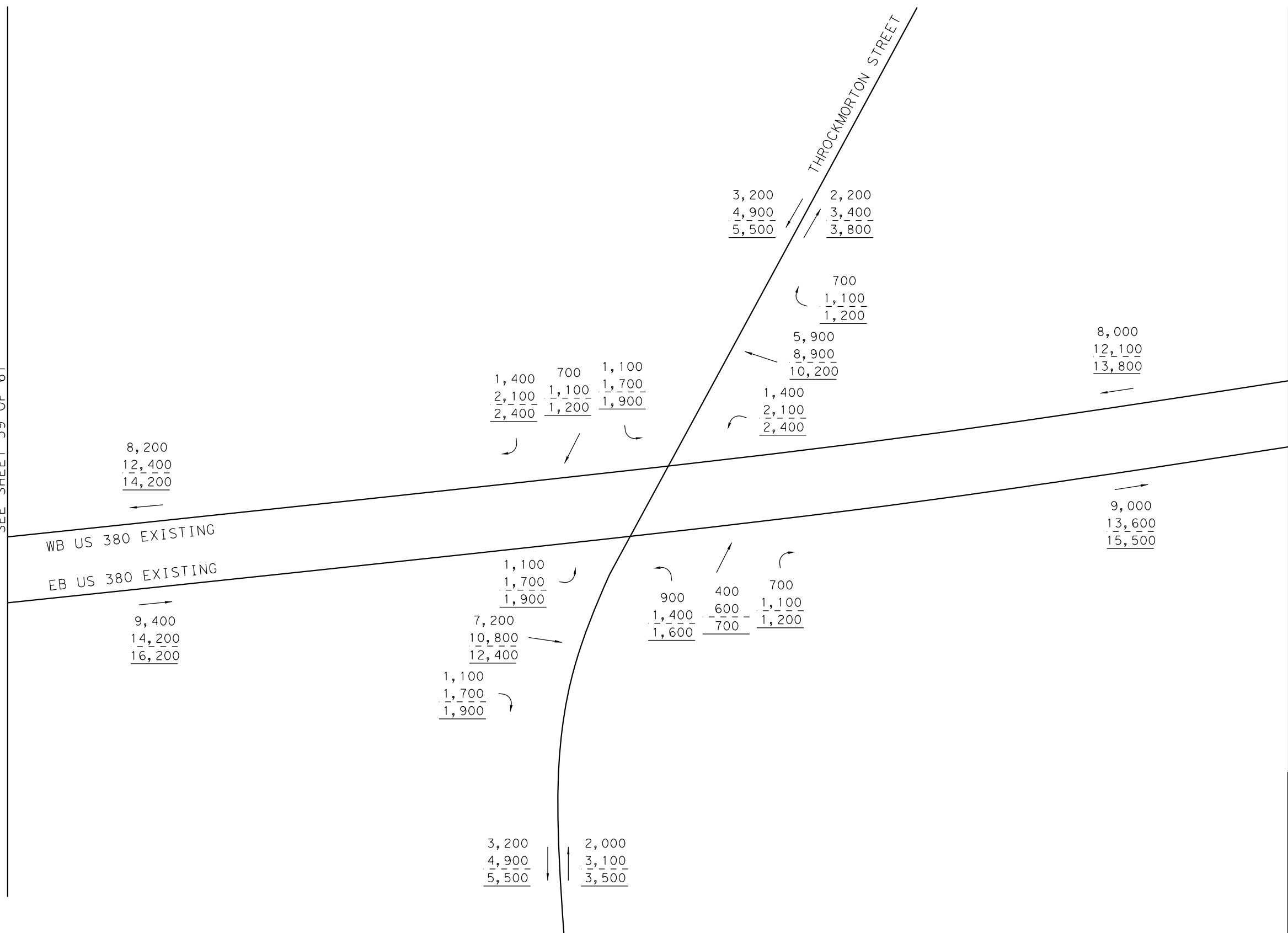
- XXXX- 2030 AVERAGE DAILY TRAFFIC VOLUMES
- XXXX- 2050 AVERAGE DAILY TRAFFIC VOLUMES
- XXXX- 2060 AVERAGE DAILY TRAFFIC VOLUMES

DATE: 7/13/2021
FILE: US380_GOLD_TRF_59.dgn



SEE SHEET 59 OF 61

SEE SHEET 61 OF 61



NOT TO SCALE

NOT INTENDED FOR CONSTRUCTION,
 BIDDING OR PERMIT PURPOSES
 DHRUVA LAHON, P.E.
 SERIAL NUMBER 102185

EXISTING US 380 AND
 THROCKMORTON ST
 AVERAGE DAILY TRAFFIC

Kimley»Horn
F-928

0135-02-065,
 ETC. SHEET 60 OF 61

LEGEND

- XXXX- 2030 AVERAGE DAILY TRAFFIC VOLUMES
- XXXX- 2050 AVERAGE DAILY TRAFFIC VOLUMES
- XXXX- 2060 AVERAGE DAILY TRAFFIC VOLUMES

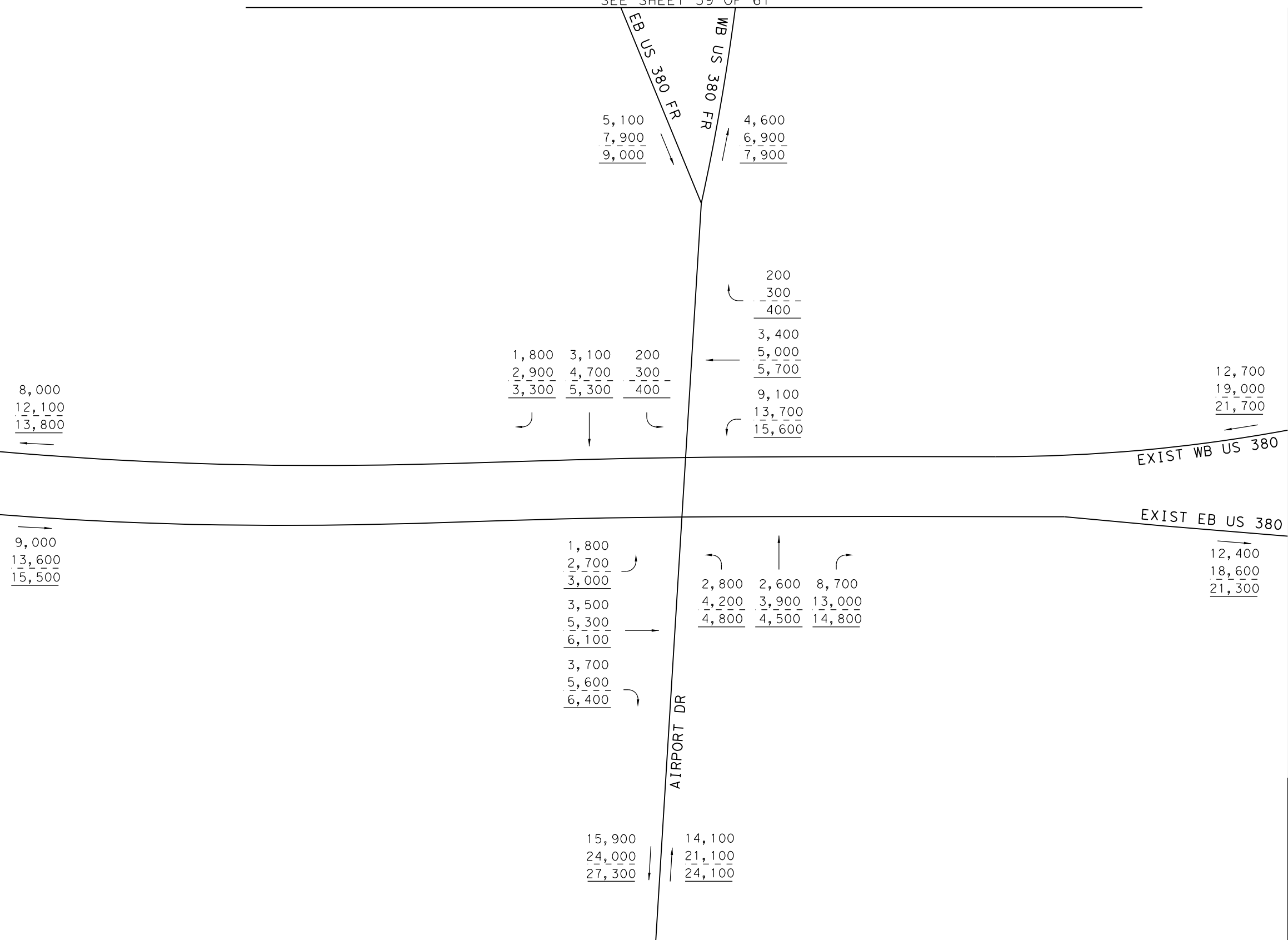
DATE: 7/13/2021
 FILE: US380_GOLD_TRF_60.dgn



SEE SHEET 39 OF 61

SEE SHEET 60 OF 61

SEE SHEET 40 OF 61



NOT TO SCALE

NOT INTENDED FOR CONSTRUCTION,
 BIDDING OR PERMIT PURPOSES
 DHRUVA LAHON, P.E.
 SERIAL NUMBER 102185

EXISTING US 380 AND
 AIRPORT DR
 AVERAGE DAILY TRAFFIC

Kimley»Horn
F-928

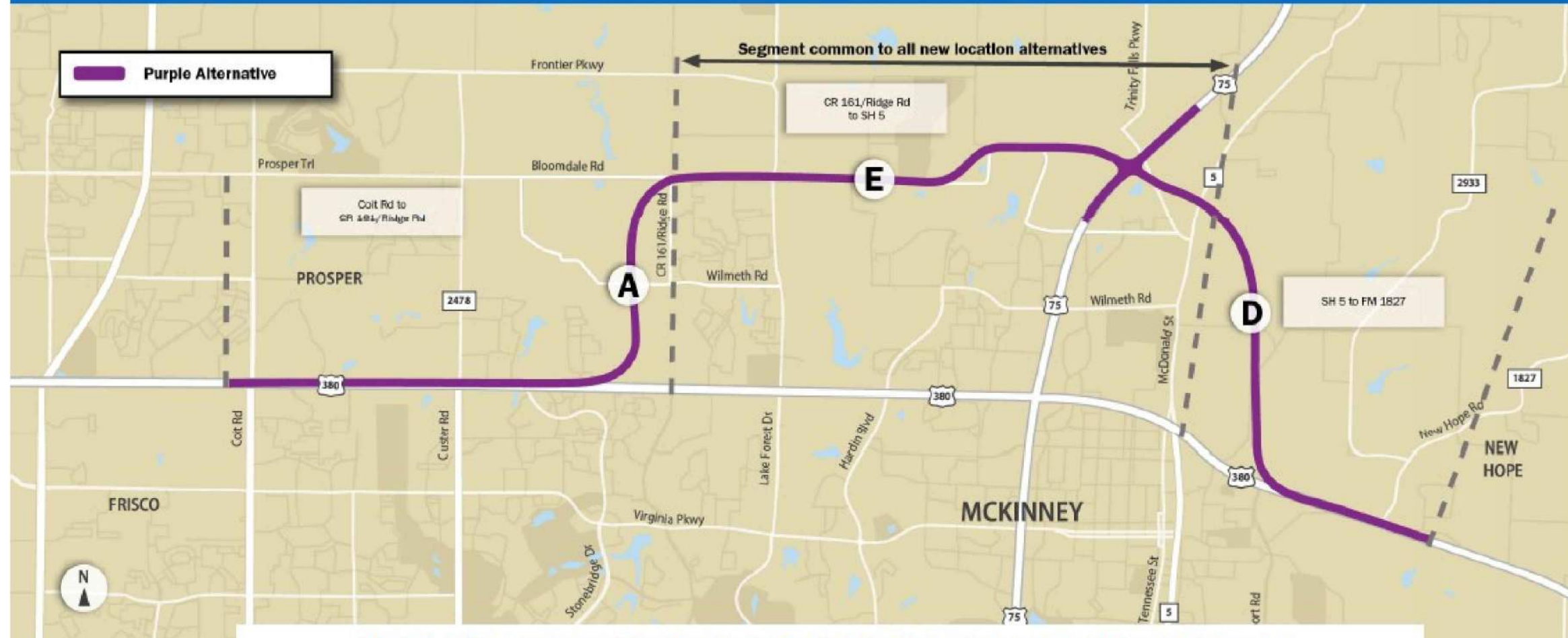
0135-02-065,
 ETC. SHEET 61 OF 61

LEGEND

- XXXX- 2030 AVERAGE DAILY TRAFFIC VOLUMES
- XXXX- 2050 AVERAGE DAILY TRAFFIC VOLUMES
- XXXX- 2060 AVERAGE DAILY TRAFFIC VOLUMES

DATE: 7/13/2021
 FILE: US380_GOLD_TRF_61.dgn

Purple Build Alternative – New Location



Modifications may continue to be made to the alternatives as the project progresses.

NOT TO SCALE

NOT INTENDED FOR CONSTRUCTION,
BIDDING OR PERMIT PURPOSES
DHURVA LAHON, P.E.
SERIAL NUMBER 102185

US 380 PURPLE ALT
KEYMAP

Kimley»Horn
F-928

0135-02-065,
ETC.

SHEET 1 OF 1



COIT ROAD

12,200	↓	11,800
18,800		↑ 18,400
<u>21,300</u>		<u>20,800</u>

3,900
6,200
<u>7,000</u>

39,600
60,400
<u>68,500</u>

3,500
5,500
<u>6,700</u>

47,000
72,100
<u>82,200</u>

WB US 380

47,800
73,100
<u>83,000</u>

WB US 380

3,800	4,300	4,100
5,900	6,500	6,400
<u>6,700</u>	<u>7,100</u>	<u>7,500</u>

EB US 380

46,300
71,400
<u>80,500</u>

3,900
6,100
<u>7,000</u>

38,400
59,100
<u>66,500</u>

4,000
6,200
<u>7,000</u>

4,400
6,800
<u>7,800</u>

4,000
6,100
<u>6,800</u>

3,500
5,300
<u>6,300</u>

EB US 380

46,000
70,800
<u>80,300</u>

SEE SHEET 2 OF 62

NOT TO SCALE

NOT INTENDED FOR CONSTRUCTION,
BIDDING OR PERMIT PURPOSES
DHURVA LAHON, P.E.
SERIAL NUMBER 102185

US 380 PURPLE ALT AND
COIT RD
AVERAGE DAILY TRAFFIC
PURPLE ALT BUILD VOLUMES

Kimley»Horn
F-928

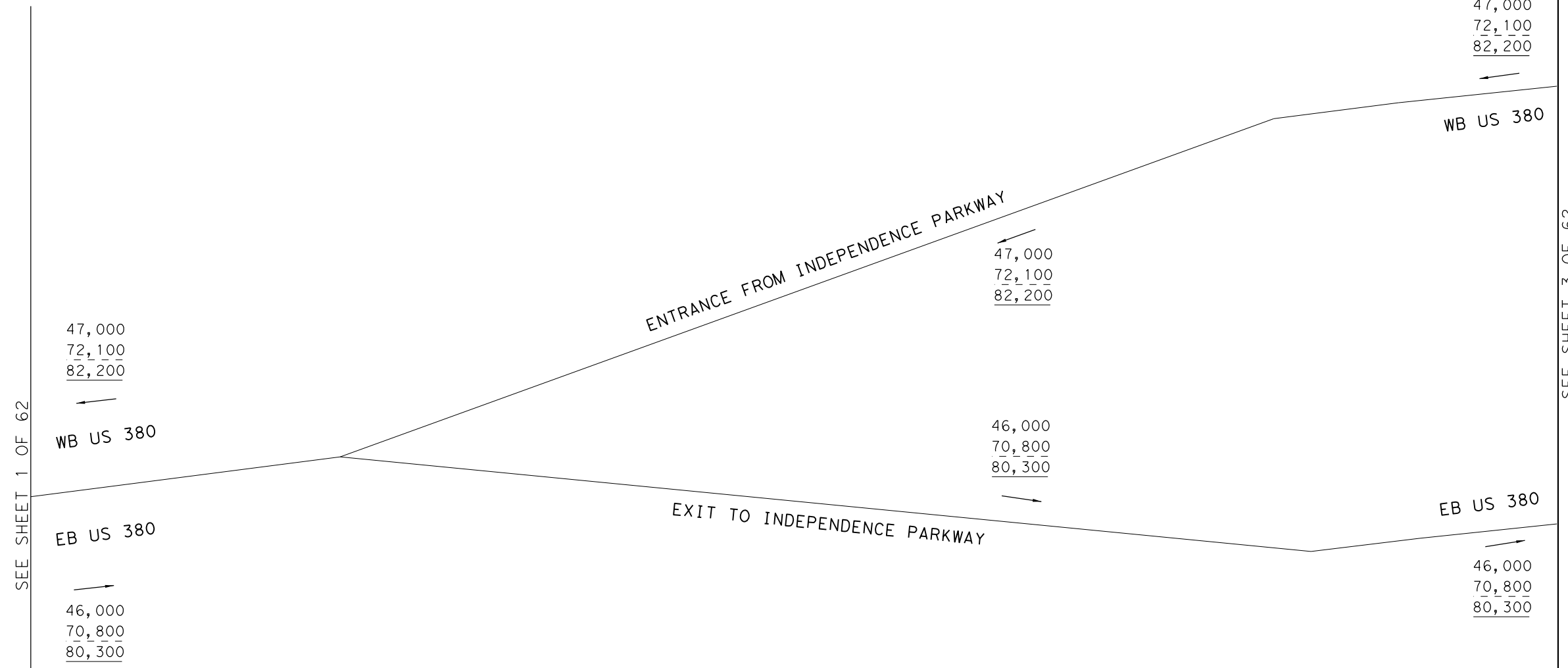
0135-02-065,
ETC.

SHEET 1 OF 62

LEGEND

- XXXX- 2030 AVERAGE DAILY TRAFFIC VOLUMES
- XXXX- 2050 AVERAGE DAILY TRAFFIC VOLUMES
- XXXX- 2060 AVERAGE DAILY TRAFFIC VOLUMES

DATE: 7/13/2021
FILE: US380_PURPLE_TRF_01.dgn



SEE SHEET 1 OF 62

SEE SHEET 3 OF 62

NOT TO SCALE

NOT INTENDED FOR CONSTRUCTION,
 BIDDING OR PERMIT PURPOSES
 DHRUVA LAHON, P.E.
 SERIAL NUMBER 102185

US 380 PURPLE ALT AND
 RAMPS
 AVERAGE DAILY TRAFFIC
 PURPLE ALT BUILD VOLUMES



0135-02-065,
 ETC. SHEET 2 OF 62

LEGEND

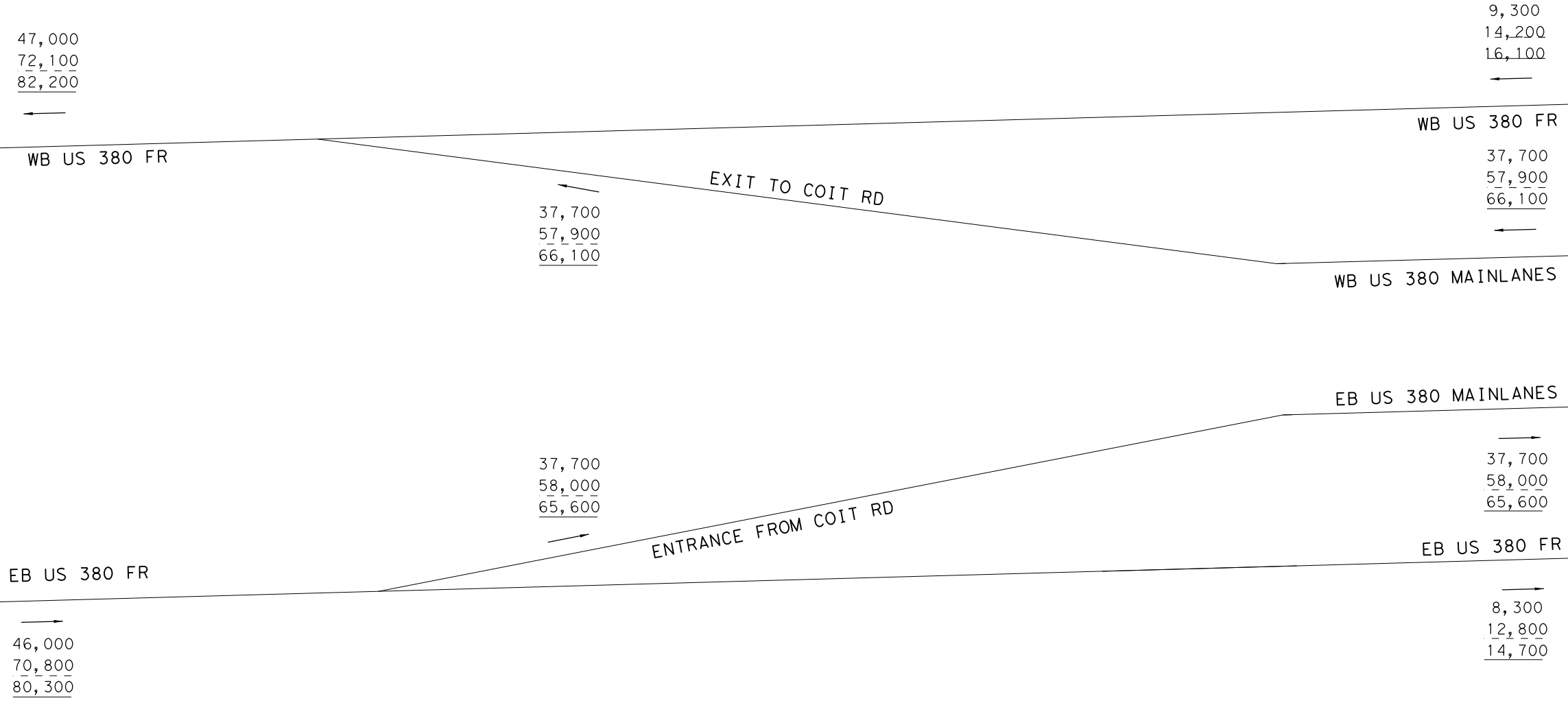
- XXXX- 2030 AVERAGE DAILY TRAFFIC VOLUMES
- XXXX- 2050 AVERAGE DAILY TRAFFIC VOLUMES
- XXXX- 2060 AVERAGE DAILY TRAFFIC VOLUMES

DATE: 7/13/2021
 FILE: US380_PURPLE_TRF_02.dgn



SEE SHEET 2 OF 62

SEE SHEET 4 OF 62



NOT TO SCALE

NOT INTENDED FOR CONSTRUCTION,
 BIDDING OR PERMIT PURPOSES
 DHRUVA LAHON, P.E.
 SERIAL NUMBER 102185

US 380 PURPLE ALT AND
 RAMPS
 AVERAGE DAILY TRAFFIC
 PURPLE ALT BUILD VOLUMES



0135-02-065,
 ETC. SHEET 3 OF 62

LEGEND

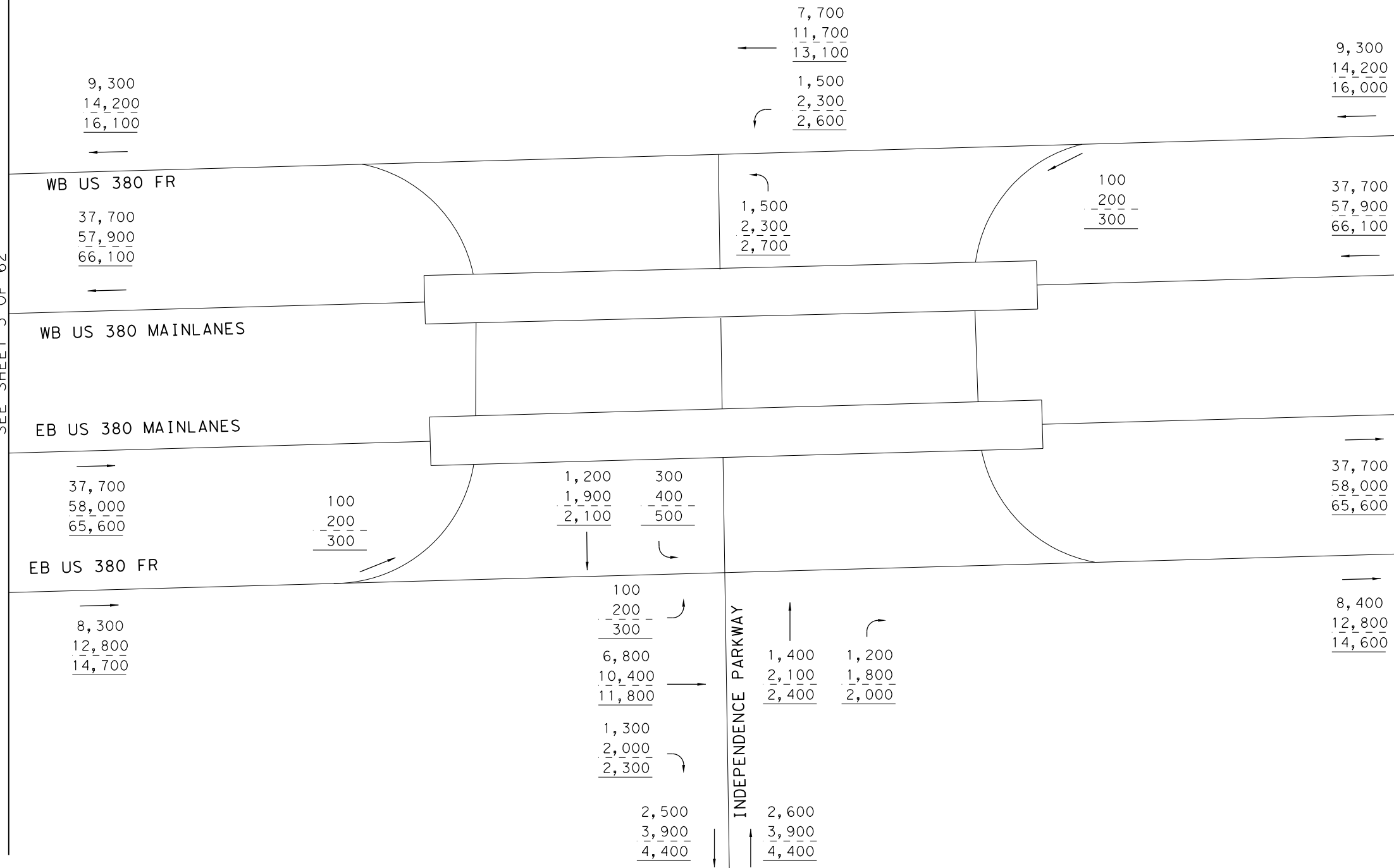
- XXXX- 2030 AVERAGE DAILY TRAFFIC VOLUMES
- XXXX- 2050 AVERAGE DAILY TRAFFIC VOLUMES
- XXXX- 2060 AVERAGE DAILY TRAFFIC VOLUMES

DATE: 7/13/2021
FILE: US380_PURPLE_TRF_03.dgn



SEE SHEET 3 OF 62

SEE SHEET 5 OF 62



NOT TO SCALE

NOT INTENDED FOR CONSTRUCTION,
 BIDDING OR PERMIT PURPOSES
 DHRUVA LAHON, P.E.
 SERIAL NUMBER 102185

US 380 PURPLE ALT AND
 INDEPENDENCE PKWY
 AVERAGE DAILY TRAFFIC
 PURPLE ALT BUILD VOLUMES



LEGEND

- XXXX- 2030 AVERAGE DAILY TRAFFIC VOLUMES
- XXXX- 2050 AVERAGE DAILY TRAFFIC VOLUMES
- XXXX- 2060 AVERAGE DAILY TRAFFIC VOLUMES



SEE SHEET 4 OF 62

SEE SHEET 6 OF 62

9,300
14,200
16,000

WB US 380 FR

37,700
57,900
66,100

WB US 380 MAINLANES

EB US 380 MAINLANES

37,700
58,000
65,600

EB US 380 FR

8,400
12,800
14,600

ENTRANCE FROM N CUSTER RD (FM 2478)

~~5,900~~ 9900
~~9,000~~ 15100
~~10,300~~ 17300

19200
29300
33300

~~15,200~~
~~23,200~~
~~26,300~~

27800
42800
48800

~~31,800~~
~~48,900~~
~~55,800~~

~~6,400~~ 9700
~~9,900~~ 15000
~~12,100~~ 17800

28000
43000
47800

~~31,300~~
~~48,100~~
~~53,500~~

EXIT TO N CUSTER RD (FM 2478)

18100
27800
32400

~~14,800~~
~~22,700~~
~~26,700~~

NOT TO SCALE

NOT INTENDED FOR CONSTRUCTION,
BIDDING OR PERMIT PURPOSES
DHURVA LAHON, P.E.
SERIAL NUMBER 102185

US 380 PURPLE ALT AND
RAMPS
AVERAGE DAILY TRAFFIC
PURPLE ALT BUILD VOLUMES

Kimley»Horn
F-928

0135-02-065,
ETC.

SHEET 5 OF 62

LEGEND

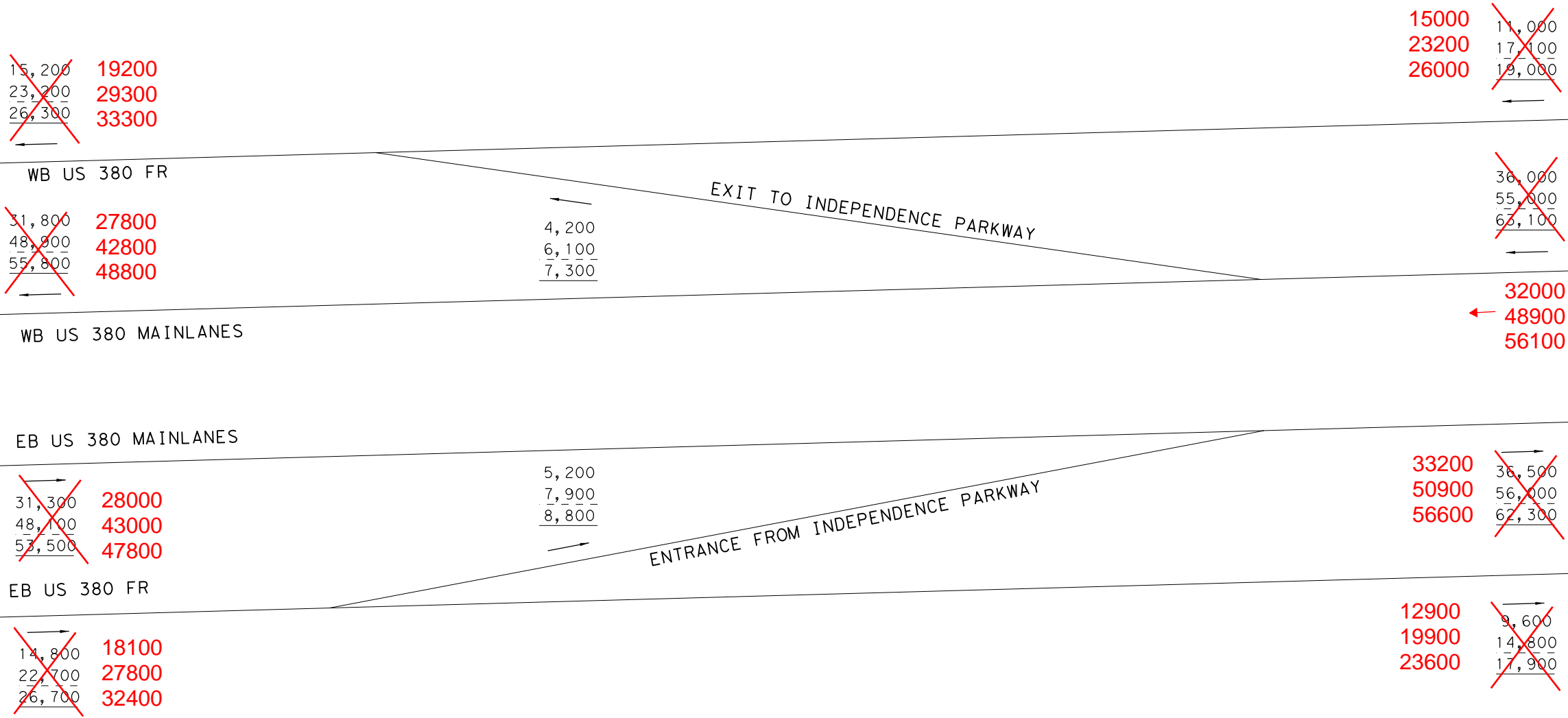
- XXXX- 2030 AVERAGE DAILY TRAFFIC VOLUMES
- XXXX- 2050 AVERAGE DAILY TRAFFIC VOLUMES
- XXXX- 2060 AVERAGE DAILY TRAFFIC VOLUMES

DATE: 7/13/2021
FILE: US380_PURPLE_TRF_05.dgn



SEE SHEET 5 OF 62

SEE SHEET 7 OF 62



NOT TO SCALE

NOT INTENDED FOR CONSTRUCTION,
 BIDDING OR PERMIT PURPOSES
 DHRUVA LAHON, P.E.
 SERIAL NUMBER 102185

US 380 PURPLE ALT AND
 RAMPS
 AVERAGE DAILY TRAFFIC
 PURPLE ALT BUILD VOLUMES



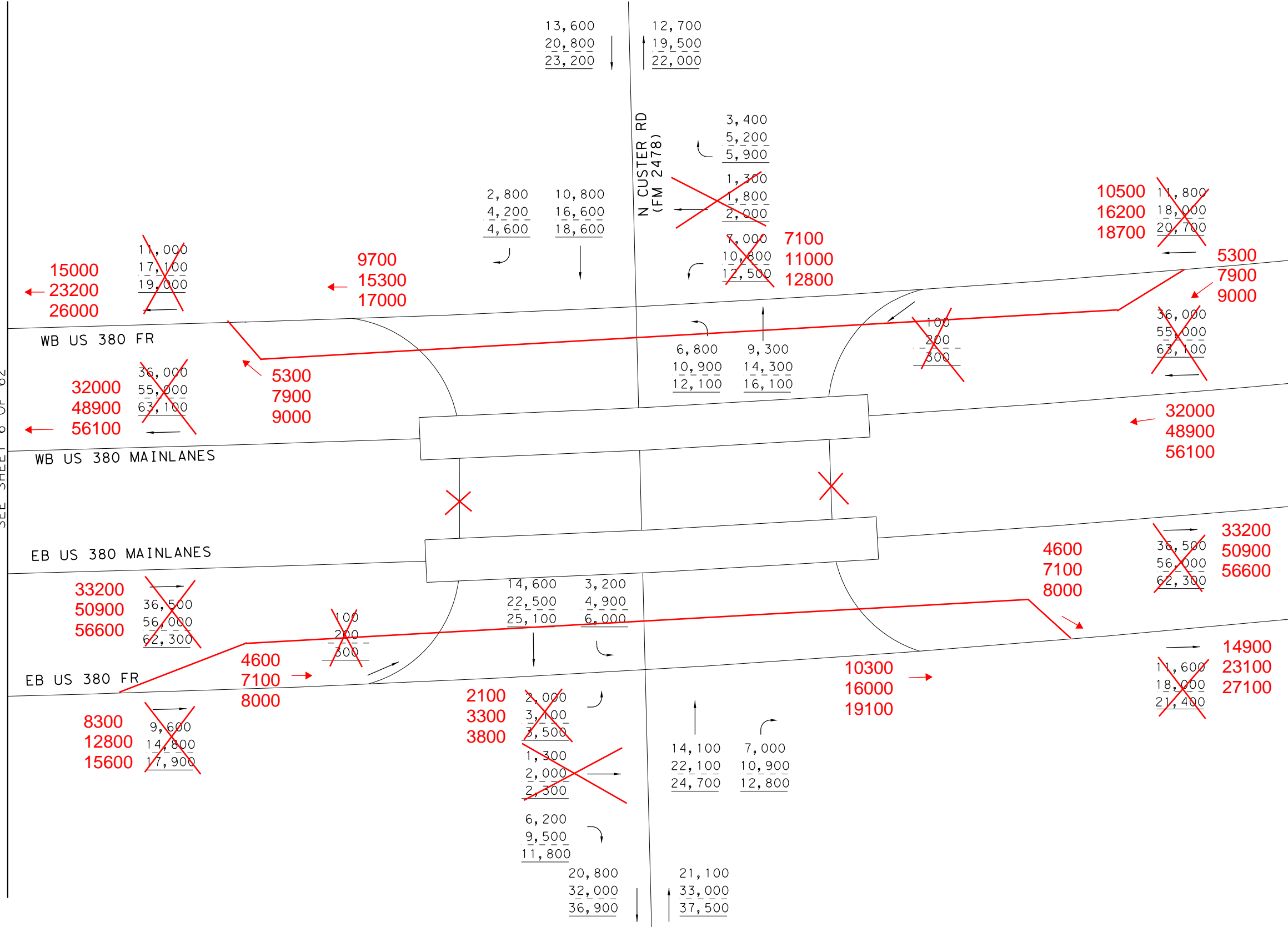
LEGEND

- XXXX- 2030 AVERAGE DAILY TRAFFIC VOLUMES
- XXXX- 2050 AVERAGE DAILY TRAFFIC VOLUMES
- XXXX- 2060 AVERAGE DAILY TRAFFIC VOLUMES



SEE SHEET 6 OF 62

SEE SHEET 8 OF 62



LEGEND

- XXXX- 2030 AVERAGE DAILY TRAFFIC VOLUMES
- XXXX- 2050 AVERAGE DAILY TRAFFIC VOLUMES
- XXXX- 2060 AVERAGE DAILY TRAFFIC VOLUMES

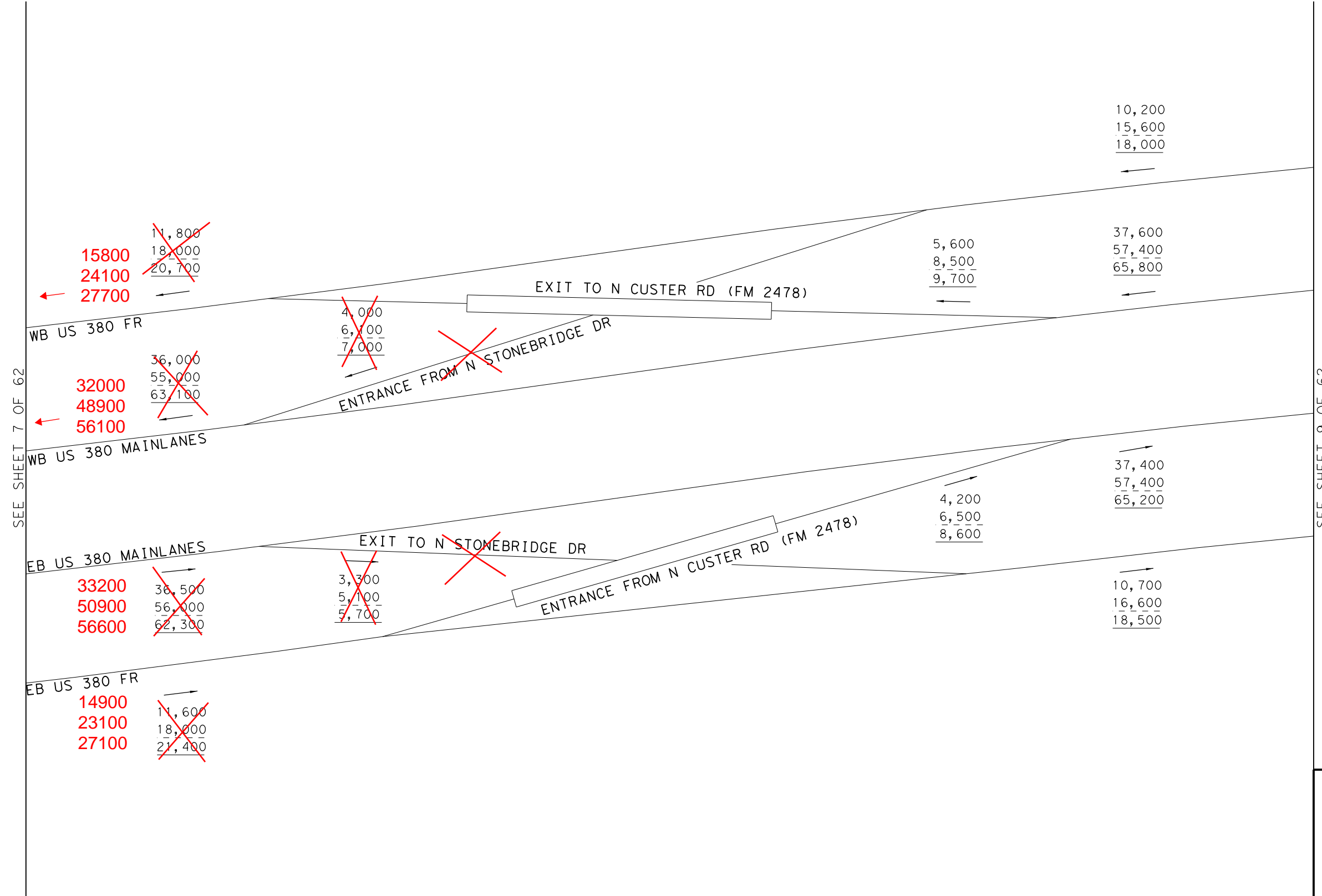
NOT TO SCALE

NOT INTENDED FOR CONSTRUCTION,
 BIDDING OR PERMIT PURPOSES
 DHRUVA LAHON, P.E.
 SERIAL NUMBER 102185

US 380 PURPLE ALT AND
 N CUSTER RD
 AVERAGE DAILY TRAFFIC
 PURPLE ALT BUILD VOLUMES



DATE: 7/13/2021
FILE: US380_PURPLE_TRF_07.dgn



NOT TO SCALE

NOT INTENDED FOR CONSTRUCTION,
BIDDING OR PERMIT PURPOSES
DHURVA LAHON, P.E.
SERIAL NUMBER 102185

US 380 PURPLE ALT AND
RAMPS
AVERAGE DAILY TRAFFIC
PURPLE ALT BUILD VOLUMES

Kimley»Horn
F-928

0135-02-065,
ETC. SHEET 8 OF 62

LEGEND

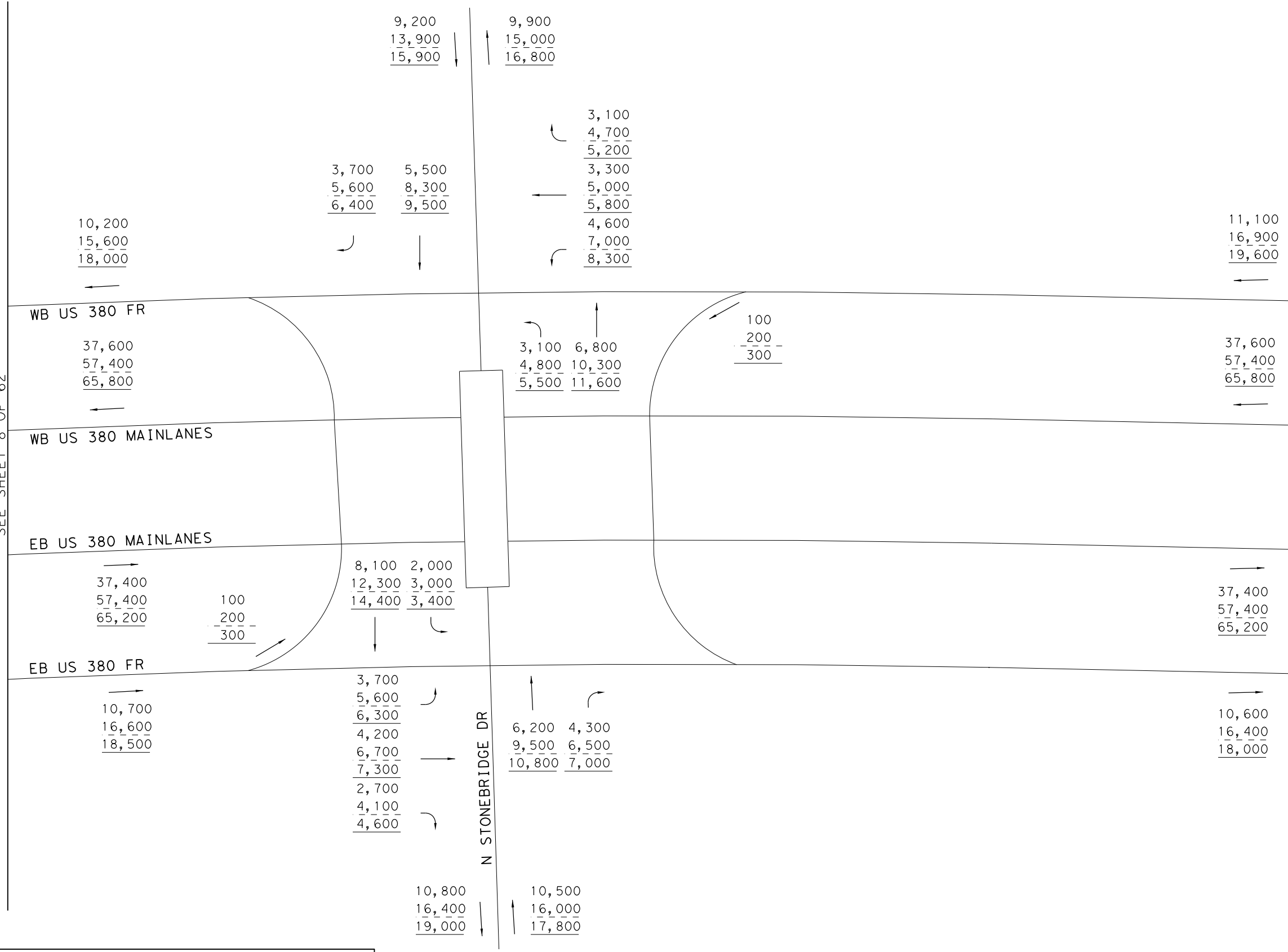
- XXXX- 2030 AVERAGE DAILY TRAFFIC VOLUMES
- XXXX- 2050 AVERAGE DAILY TRAFFIC VOLUMES
- XXXX- 2060 AVERAGE DAILY TRAFFIC VOLUMES

DATE: 7/13/2021
FILE: US380_PURPLE_TRF_08.dgn



SEE SHEET 8 OF 62

SEE SHEET 10 OF 62



LEGEND

- XXXX- 2030 AVERAGE DAILY TRAFFIC VOLUMES
- XXXX- 2050 AVERAGE DAILY TRAFFIC VOLUMES
- XXXX- 2060 AVERAGE DAILY TRAFFIC VOLUMES

NOT TO SCALE

NOT INTENDED FOR CONSTRUCTION,
 BIDDING OR PERMIT PURPOSES
 DHRUVA LAHON, P.E.
 SERIAL NUMBER 102185

US 380 PURPLE ALT AND
 STONEBRIDGE DR
 AVERAGE DAILY TRAFFIC
 PURPLE ALT BUILD VOLUMES



DATE: 7/13/2021
 FILE: US380_PURPLE_TRF_09.dgn



SEE SHEET 9 OF 62

SEE SHEET 11 OF 62

11,100
16,900
19,600

WB US 380 FR
37,600
57,400
65,800

WB US 380 MAINLANES

EB US 380 MAINLANES

37,400
57,400
65,200

EB US 380 FR

10,600
16,400
18,000

2,500
3,800
4,900

2,400
3,700
4,000

2,500
3,800
4,900

TREMONT BLVD

2,400
3,700
4,000
8,600
13,100
14,700

11,000
16,800
18,700

NOT TO SCALE

NOT INTENDED FOR CONSTRUCTION,
BIDDING OR PERMIT PURPOSES
DHURVA LAHON, P.E.
SERIAL NUMBER 102185

US 380 PURPLE ALT AND
TREMONT BLVD
AVERAGE DAILY TRAFFIC
PURPLE ALT BUILD VOLUMES

Kimley»Horn
F-928

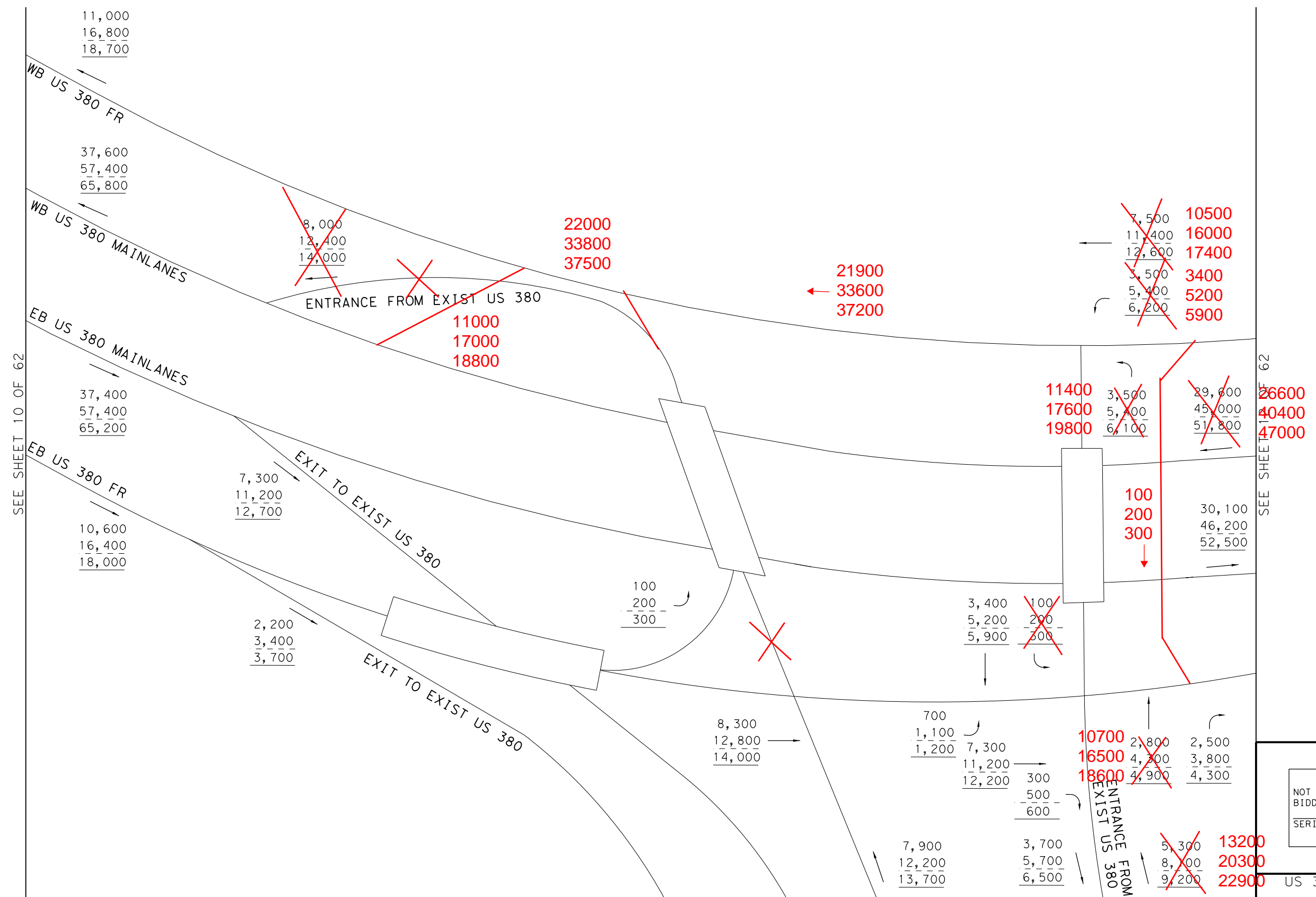
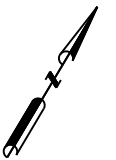
0135-02-065,
ETC.

SHEET 10 OF 62

LEGEND

- XXXX- 2030 AVERAGE DAILY TRAFFIC VOLUMES
- XXXX- 2050 AVERAGE DAILY TRAFFIC VOLUMES
- XXXX- 2060 AVERAGE DAILY TRAFFIC VOLUMES

DATE: 7/13/2021
FILE: US380_PURPLE_TRF_10.dgn



SEE SHEET 10 OF 62

SEE SHEET 11 OF 62

SEE SHEET 11A OF 62

NOT TO SCALE

NOT INTENDED FOR CONSTRUCTION,
BIDDING OR PERMIT PURPOSES
DHURVA LAHON, P.E.
SERIAL NUMBER 102185

US 380 PURPLE ALT AND
RAMP
AVERAGE DAILY TRAFFIC
PURPLE ALT BUILD VOLUMES

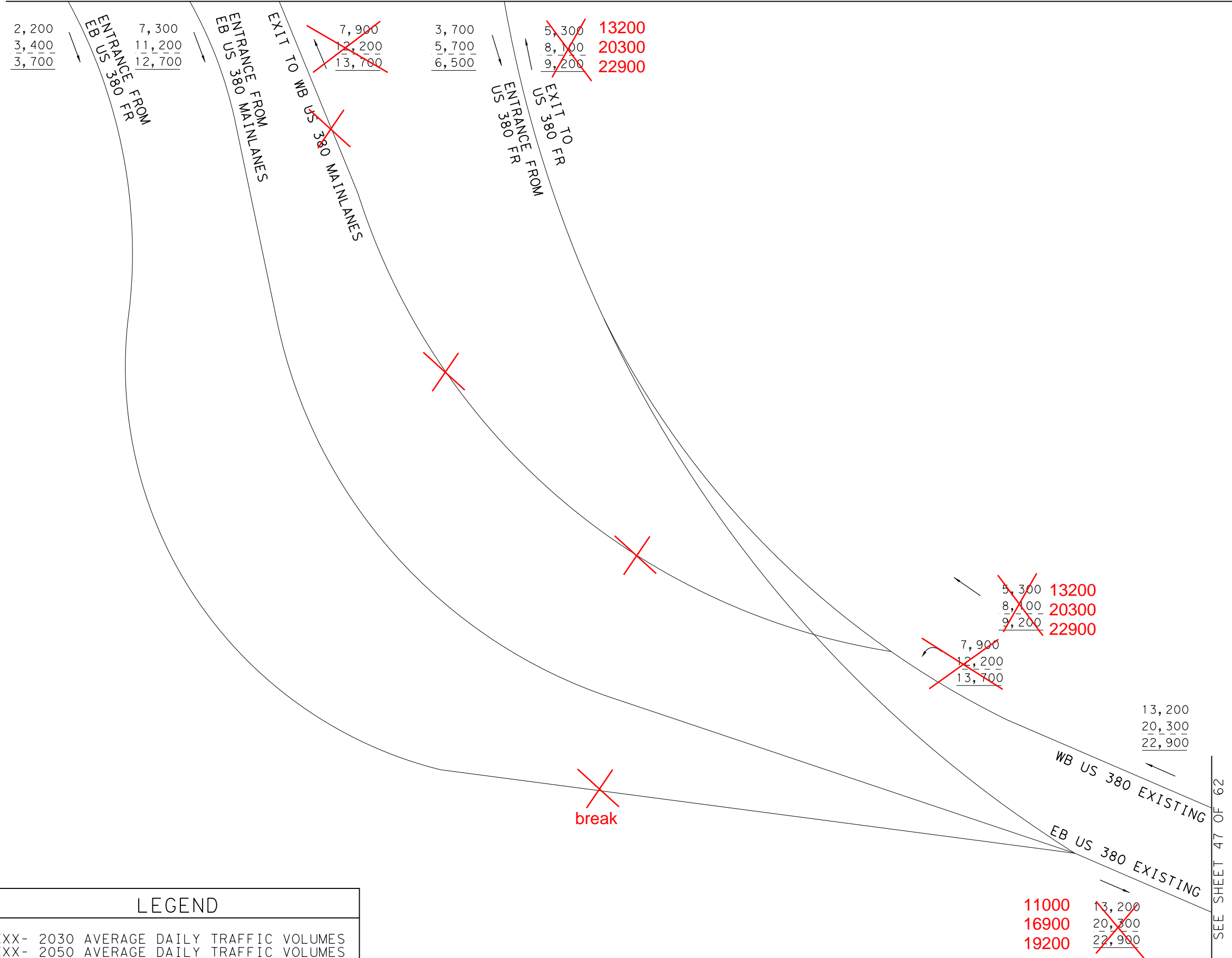
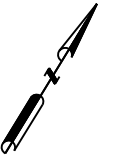
Kimley»Horn
F-928

0135-02-065,
ETC. SHEET 11 OF 62

LEGEND

- XXXX- 2030 AVERAGE DAILY TRAFFIC VOLUMES
- XXXX- 2050 AVERAGE DAILY TRAFFIC VOLUMES
- XXXX- 2060 AVERAGE DAILY TRAFFIC VOLUMES

DATE: 7/13/2021
FILE: US380_PURPLE_TRF_11.dgn



2,200
3,400
3,700

7,300
11,200
12,700

~~7,900~~
~~12,200~~
~~13,700~~

3,700
5,700
6,500

~~5,300~~
~~8,100~~
~~9,200~~

13200
20300
22900

~~5,300~~
~~8,100~~
~~9,200~~

13200
20300
22900

~~7,900~~
~~12,200~~
~~13,700~~

13,200
20,300
22,900

~~13,200~~
~~20,300~~
~~22,900~~

11000
16900
19200

SEE SHEET 47 OF 62

NOT TO SCALE

NOT INTENDED FOR CONSTRUCTION,
BIDDING OR PERMIT PURPOSES
DHURVA LAHON, P.E.
SERIAL NUMBER 102185

US 380 PURPLE ALT AND
EXISTING US 380
AVERAGE DAILY TRAFFIC
PURPLE ALT BUILD VOLUMES

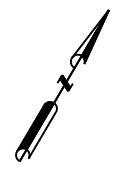
Kimley»Horn
F-928

0135-02-065,
ETC.

SHEET 11A OF 62

LEGEND

- XXXX- 2030 AVERAGE DAILY TRAFFIC VOLUMES
- XXXX- 2050 AVERAGE DAILY TRAFFIC VOLUMES
- XXXX- 2060 AVERAGE DAILY TRAFFIC VOLUMES



SEE SHEET 11 OF 62

SEE SHEET 13 OF 62

~~11,000~~ 14000
~~16,800~~ 21400
~~18,800~~ 23600

WB US 380 FR

~~29,600~~ 26600
~~45,000~~ 40400
~~51,800~~ 47000

WB US 380 MAINLANES

EB US 380 MAINLANES

30,100
46,200
52,500

EB US 380 FR

9,900
15,200
16,800

~~4,200~~
~~6,000~~
~~7,900~~
7200
10600
12700

~~36,400~~
~~55,800~~
~~62,700~~
33400
51200
57900

6,800
10,800
10,900

EXIT TO EXIST US 380

~~34,000~~
~~52,400~~
~~59,300~~
27300
41900
47600

~~6,000~~
~~9,000~~
~~10,000~~
12700
19500
21700

CR 124 OFR

2800
4300
4900

~~3,900~~
~~6,200~~
~~6,800~~

ENTRANCE FROM EXIST US 380

NOT TO SCALE

NOT INTENDED FOR CONSTRUCTION,
BIDDING OR PERMIT PURPOSES
DHURVA LAHON, P.E.
SERIAL NUMBER 102185

US 380 PURPLE ALT AND
RAMPS
AVERAGE DAILY TRAFFIC
PURPLE ALT BUILD VOLUMES

Kimley»Horn
F-928

0135-02-065,
ETC. SHEET 12 OF 62

LEGEND

- XXXX- 2030 AVERAGE DAILY TRAFFIC VOLUMES
- XXXX- 2050 AVERAGE DAILY TRAFFIC VOLUMES
- XXXX- 2060 AVERAGE DAILY TRAFFIC VOLUMES

DATE: 7/13/2021
FILE: US380_PURPLE_TRF_12.dgn



SEE SHEET 12 OF 62

SEE SHEET 14 OF 62

4,200	7200
6,000	10600
7,900	12700

7,200
10,600
12,700

WB US 380 FR

36,400	33400
55,800	51200
62,700	57900

3,000
4,800
4,800

ENTRANCE FROM CR 124

33,400
51,200
57,900

WB US 380 MAINLANES

EB US 380 MAINLANES

27300	34,000	3900
41900	52,400	6200
47600	59,300	6800

Exist US 380 ONR

2,800
4,800
4,900

EXIT TO CR 124

31,200
48,100
54,400

EB US 380 FR

12700	6,000
19500	9,000
21700	10,000

8,800
13,300
14,900

NOT TO SCALE

NOT INTENDED FOR CONSTRUCTION,
BIDDING OR PERMIT PURPOSES
DHURVA LAHON, P.E.
SERIAL NUMBER 102185

US 380 PURPLE ALT AND
RAMPS
AVERAGE DAILY TRAFFIC
PURPLE ALT BUILD VOLUMES

Kimley»Horn
F-928

0135-02-065,
ETC. SHEET 13 OF 62

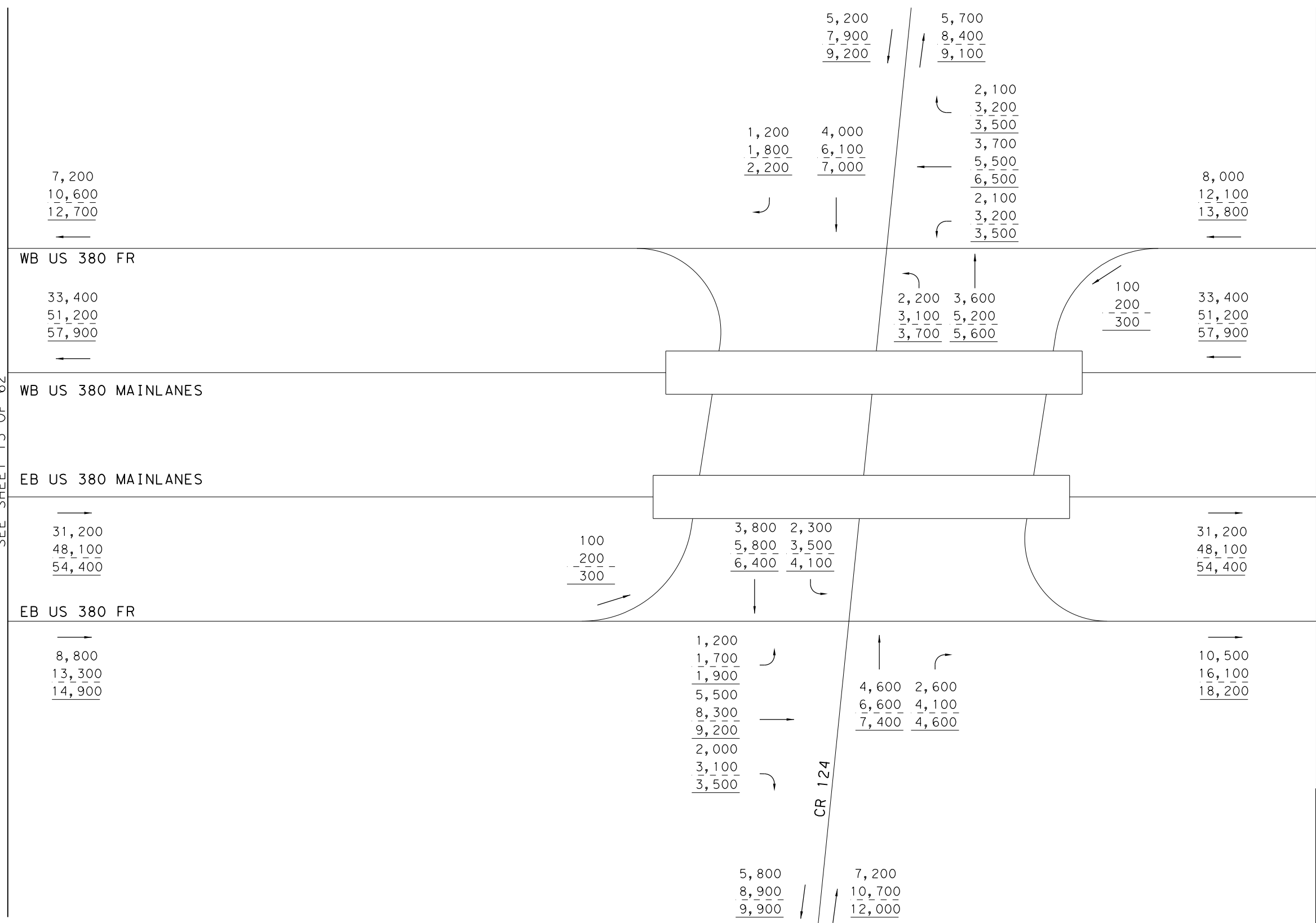
LEGEND

- XXXX- 2030 AVERAGE DAILY TRAFFIC VOLUMES
- XXXX- 2050 AVERAGE DAILY TRAFFIC VOLUMES
- XXXX- 2060 AVERAGE DAILY TRAFFIC VOLUMES



SEE SHEET 13 OF 62

SEE SHEET 15 OF 62



NOT TO SCALE

NOT INTENDED FOR CONSTRUCTION,
 BIDDING OR PERMIT PURPOSES
 DHRUVA LAHON, P.E.
 SERIAL NUMBER 102185

US 380 PURPLE ALT AND
 CR 124
 AVERAGE DAILY TRAFFIC
 PURPLE ALT BUILD VOLUMES



0135-02-065,
 ETC. SHEET 14 OF 62

LEGEND

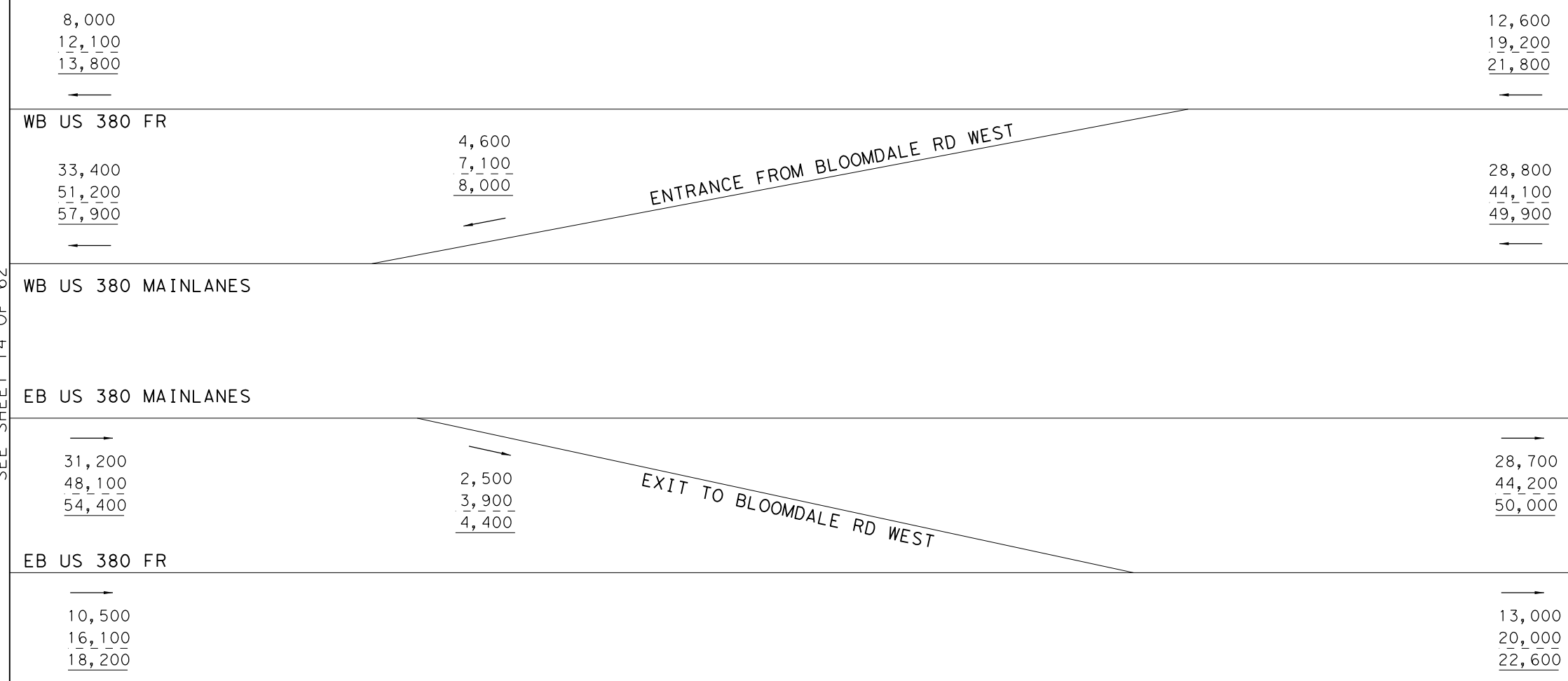
- XXXX- 2030 AVERAGE DAILY TRAFFIC VOLUMES
- XXXX- 2050 AVERAGE DAILY TRAFFIC VOLUMES
- XXXX- 2060 AVERAGE DAILY TRAFFIC VOLUMES

DATE: 7/13/2021
 FILE: US380_PURPLE_TRF_14.dgn



SEE SHEET 14 OF 62

SEE SHEET 16 OF 62



NOT TO SCALE

NOT INTENDED FOR CONSTRUCTION,
BIDDING OR PERMIT PURPOSES
DHURVA LAHON, P.E.
SERIAL NUMBER 102185

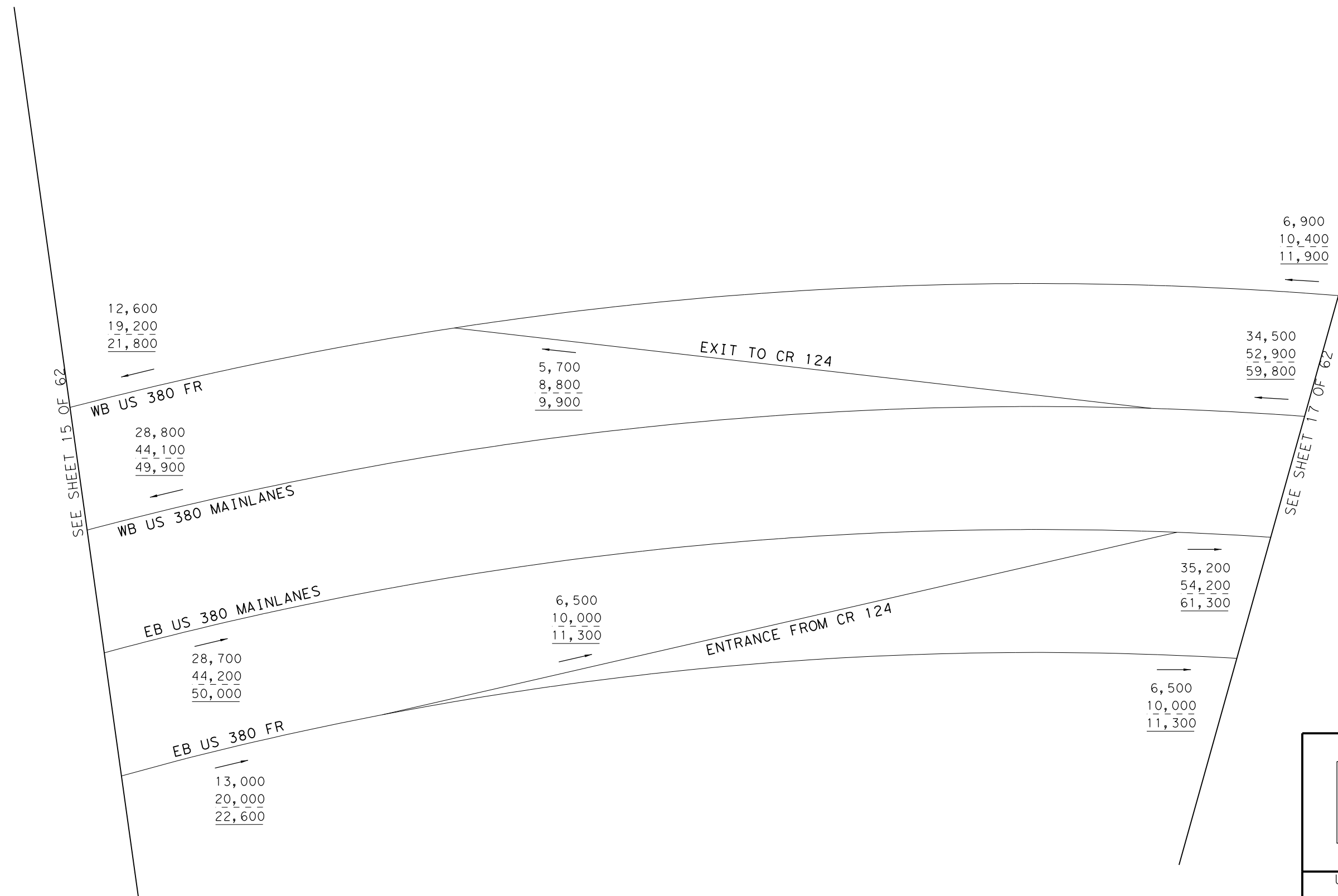
US 380 PURPLE ALT AND
RAMPS
AVERAGE DAILY TRAFFIC
PURPLE ALT BUILD VOLUMES



0135-02-065,
ETC. SHEET 15 OF 62

LEGEND

- XXXX- 2030 AVERAGE DAILY TRAFFIC VOLUMES
- XXXX- 2050 AVERAGE DAILY TRAFFIC VOLUMES
- XXXX- 2060 AVERAGE DAILY TRAFFIC VOLUMES



12,600
19,200
21,800

28,800
44,100
49,900

28,700
44,200
50,000

13,000
20,000
22,600

5,700
8,800
9,900

6,500
10,000
11,300

6,900
10,400
11,900

34,500
52,900
59,800

35,200
54,200
61,300

6,500
10,000
11,300

LEGEND

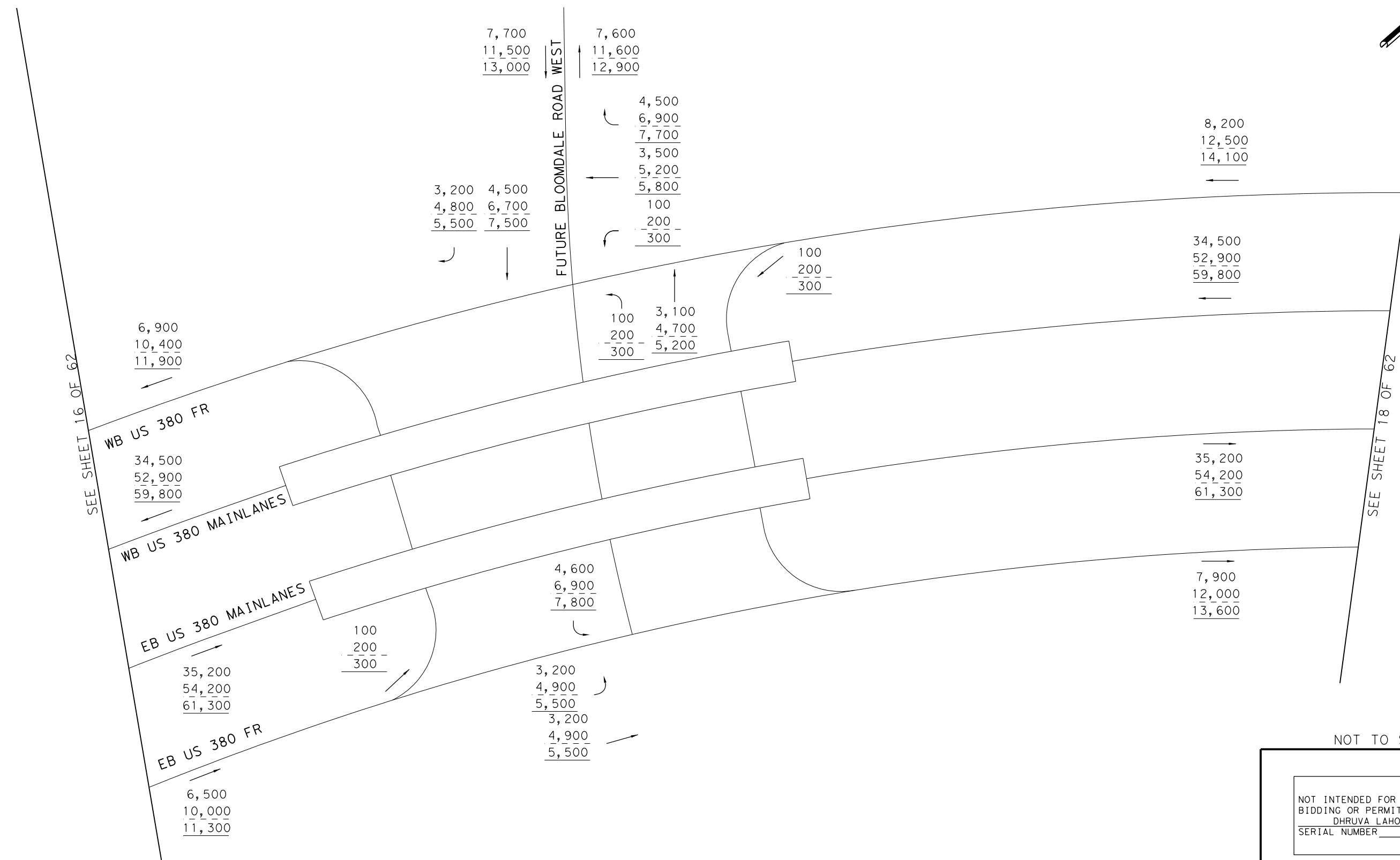
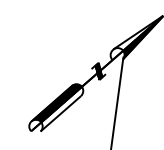
- XXXX- 2030 AVERAGE DAILY TRAFFIC VOLUMES
- XXXX- 2050 AVERAGE DAILY TRAFFIC VOLUMES
- XXXX- 2060 AVERAGE DAILY TRAFFIC VOLUMES

NOT TO SCALE

NOT INTENDED FOR CONSTRUCTION,
BIDDING OR PERMIT PURPOSES
DHURVA LAHON, P.E.
SERIAL NUMBER 102185

US 380 PURPLE ALT AND
RAMPS
AVERAGE DAILY TRAFFIC
PURPLE BUILD VOLUMES





SEE SHEET 16 OF 62

SEE SHEET 18 OF 62

FUTURE BLOOMDALE ROAD WEST

WB US 380 FR

WB US 380 MAINLANES

EB US 380 MAINLANES

EB US 380 FR

LEGEND

- XXXX- 2030 AVERAGE DAILY TRAFFIC VOLUMES
- XXXX- 2050 AVERAGE DAILY TRAFFIC VOLUMES
- XXXX- 2060 AVERAGE DAILY TRAFFIC VOLUMES

NOT TO SCALE

NOT INTENDED FOR CONSTRUCTION,
 BIDDING OR PERMIT PURPOSES
 DHRUVA LAHON, P.E.
 SERIAL NUMBER 102185

US 380 PURPLE ALT AND
 W BLOOMDALE RD
 AVERAGE DAILY TRAFFIC
 PURPLE ALT BUILD VOLUMES

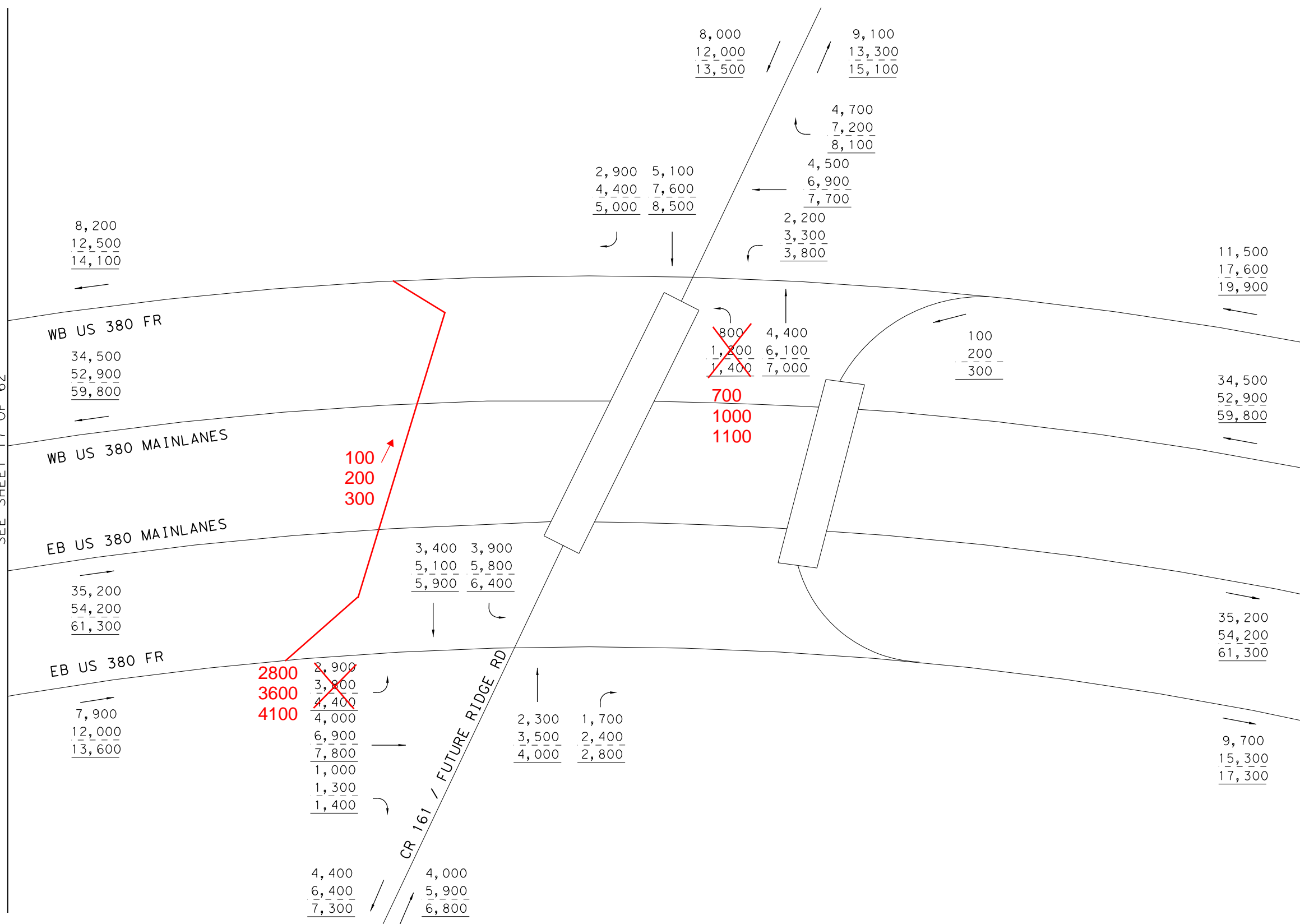


DATE: 7/13/2021
 FILE: US380_PURPLE_TRF_17.dgn



SEE SHEET 17 OF 62

SEE SHEET 19 OF 62



NOT TO SCALE

NOT INTENDED FOR CONSTRUCTION,
BIDDING OR PERMIT PURPOSES
DHURVA LAHON, P.E.
SERIAL NUMBER 102185

US 380 PURPLE ALT AND
CR 161 / FUTURE RIDGE RD
AVERAGE DAILY TRAFFIC
PURPLE ALT BUILD VOLUMES

Kimley»Horn
F-928

0135-02-065,
ETC. SHEET 18 OF 62

LEGEND

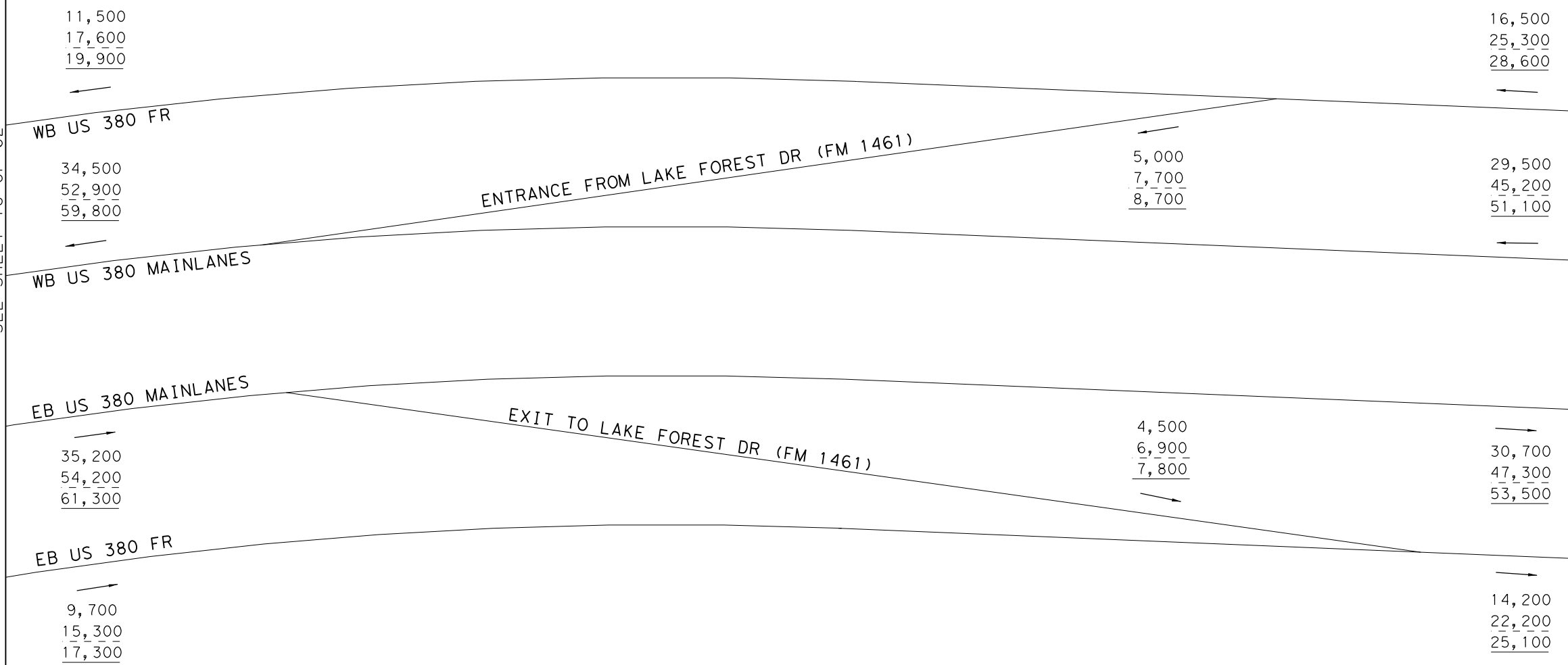
- XXXX- 2030 AVERAGE DAILY TRAFFIC VOLUMES
- XXXX- 2050 AVERAGE DAILY TRAFFIC VOLUMES
- XXXX- 2060 AVERAGE DAILY TRAFFIC VOLUMES

DATE: 7/13/2021
FILE: US380_PURPLE_TRF_18.dgn



SEE SHEET 18 OF 62

SEE SHEET 20 OF 62



NOT TO SCALE

NOT INTENDED FOR CONSTRUCTION,
 BIDDING OR PERMIT PURPOSES
 DHRUVA LAHON, P.E.
 SERIAL NUMBER 102185

US 380 PURPLE ALT AND
 RAMPS
 AVERAGE DAILY TRAFFIC
 PURPLE ALT BUILD VOLUMES

Kimley»Horn
F-928

0135-02-065,
 ETC. SHEET 19 OF 62

LEGEND

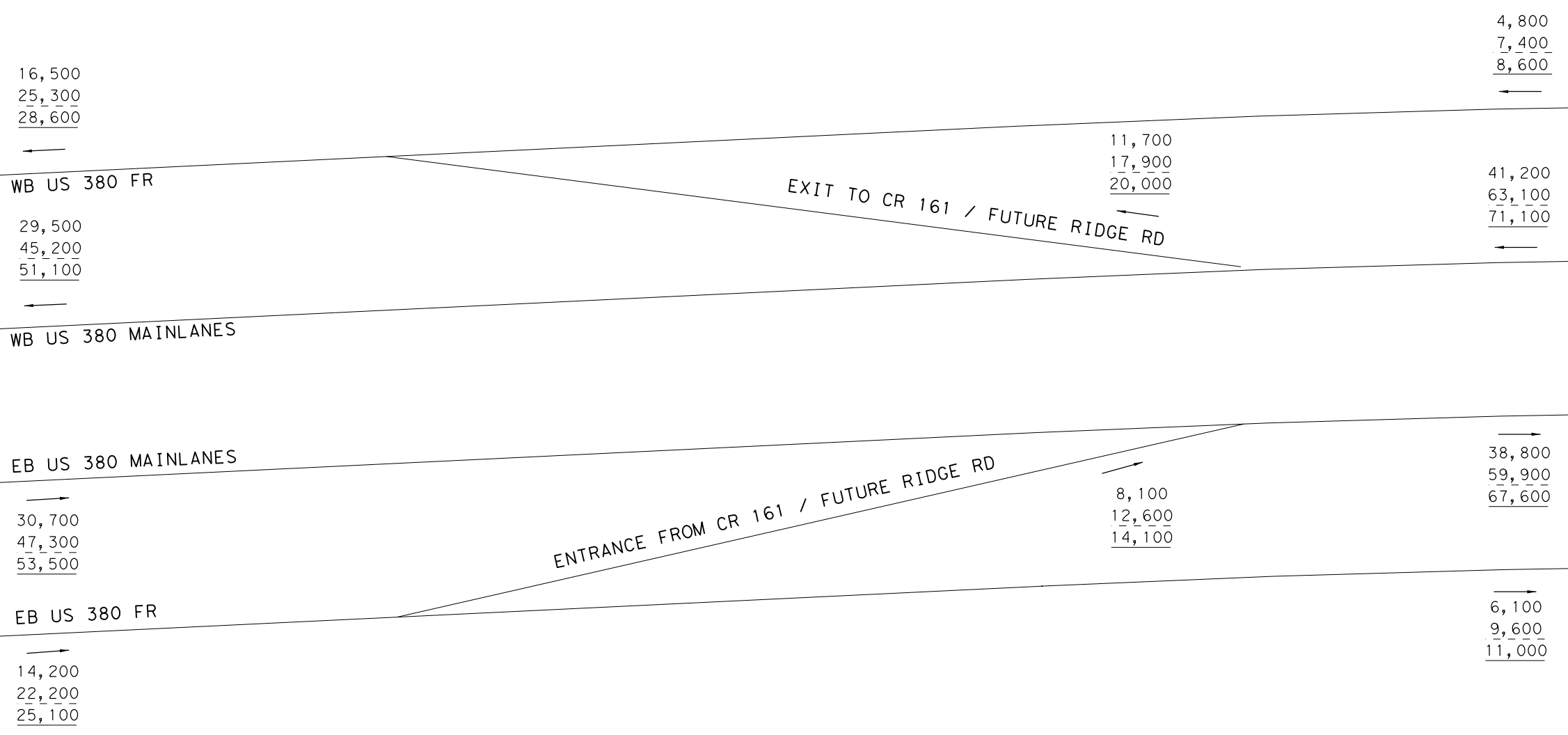
- XXXX- 2030 AVERAGE DAILY TRAFFIC VOLUMES
- XXXX- 2050 AVERAGE DAILY TRAFFIC VOLUMES
- XXXX- 2060 AVERAGE DAILY TRAFFIC VOLUMES

DATE: 7/13/2021
FILE: US380_PURPLE_TRF_19.dgn



SEE SHEET 19 OF 62

SEE SHEET 21 OF 62



NOT TO SCALE

NOT INTENDED FOR CONSTRUCTION,
 BIDDING OR PERMIT PURPOSES
 DHRUVA LAHON, P.E.
 SERIAL NUMBER 102185

US 380 PURPLE ALT AND
 RAMPS
 AVERAGE DAILY TRAFFIC
 PURPLE ALT BUILD VOLUMES

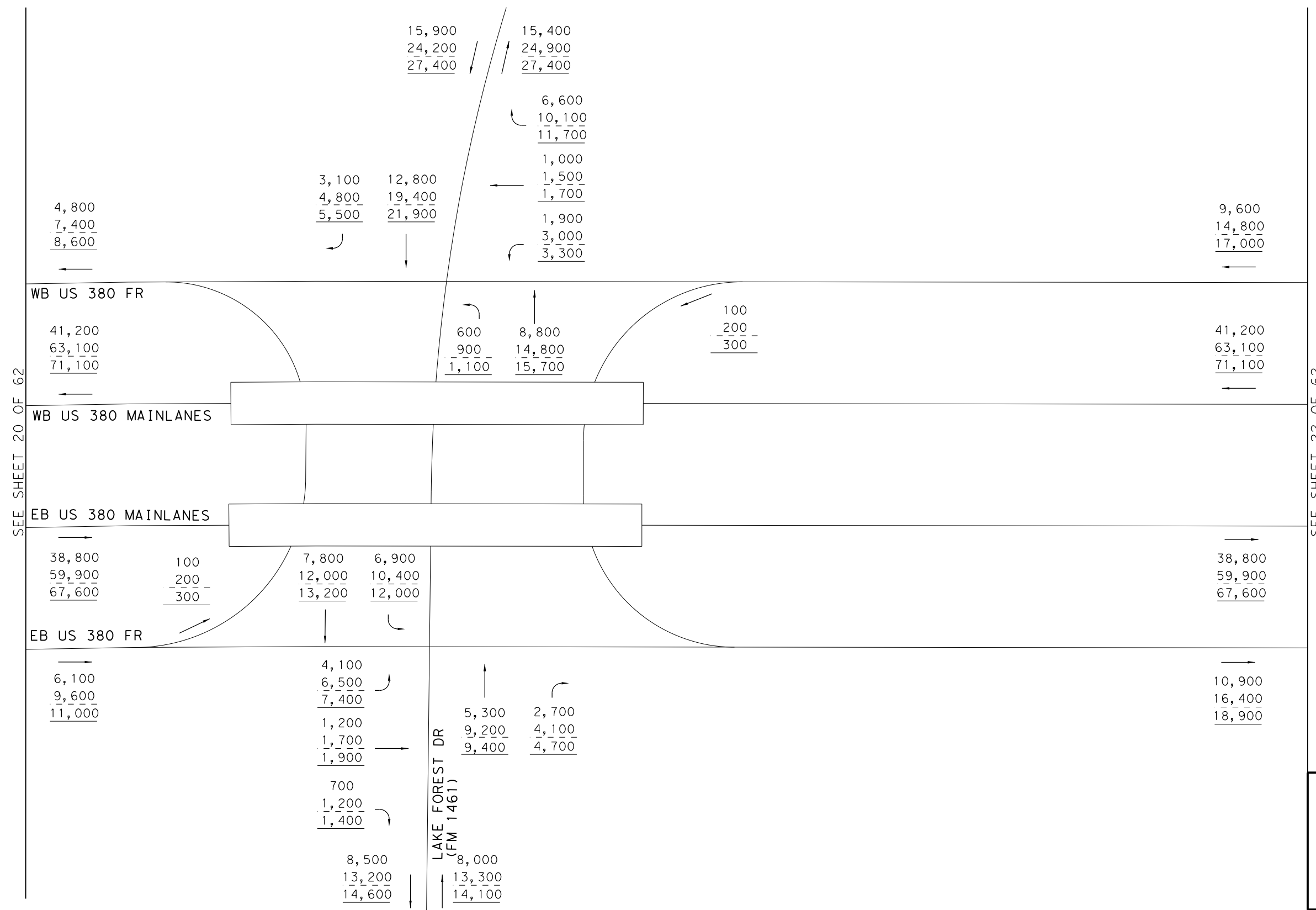


0135-02-065,
 ETC. SHEET 20 OF 62

LEGEND

- XXXX- 2030 AVERAGE DAILY TRAFFIC VOLUMES
- XXXX- 2050 AVERAGE DAILY TRAFFIC VOLUMES
- XXXX- 2060 AVERAGE DAILY TRAFFIC VOLUMES

DATE: 7/13/2021
 FILE: US380_PURPLE_TRF_20.dgn



SEE SHEET 20 OF 62

SEE SHEET 22 OF 62

NOT TO SCALE

NOT INTENDED FOR CONSTRUCTION,
 BIDDING OR PERMIT PURPOSES
 DHRUVA LAHON, P.E.
 SERIAL NUMBER 102185

US 380 PURPLE ALT AND
 LAKE FOREST DR
 AVERAGE DAILY TRAFFIC
 PURPLE ALT BUILD VOLUMES

Kimley»Horn
F-928

0135-02-065,
 ETC. SHEET 21 OF 62

LEGEND

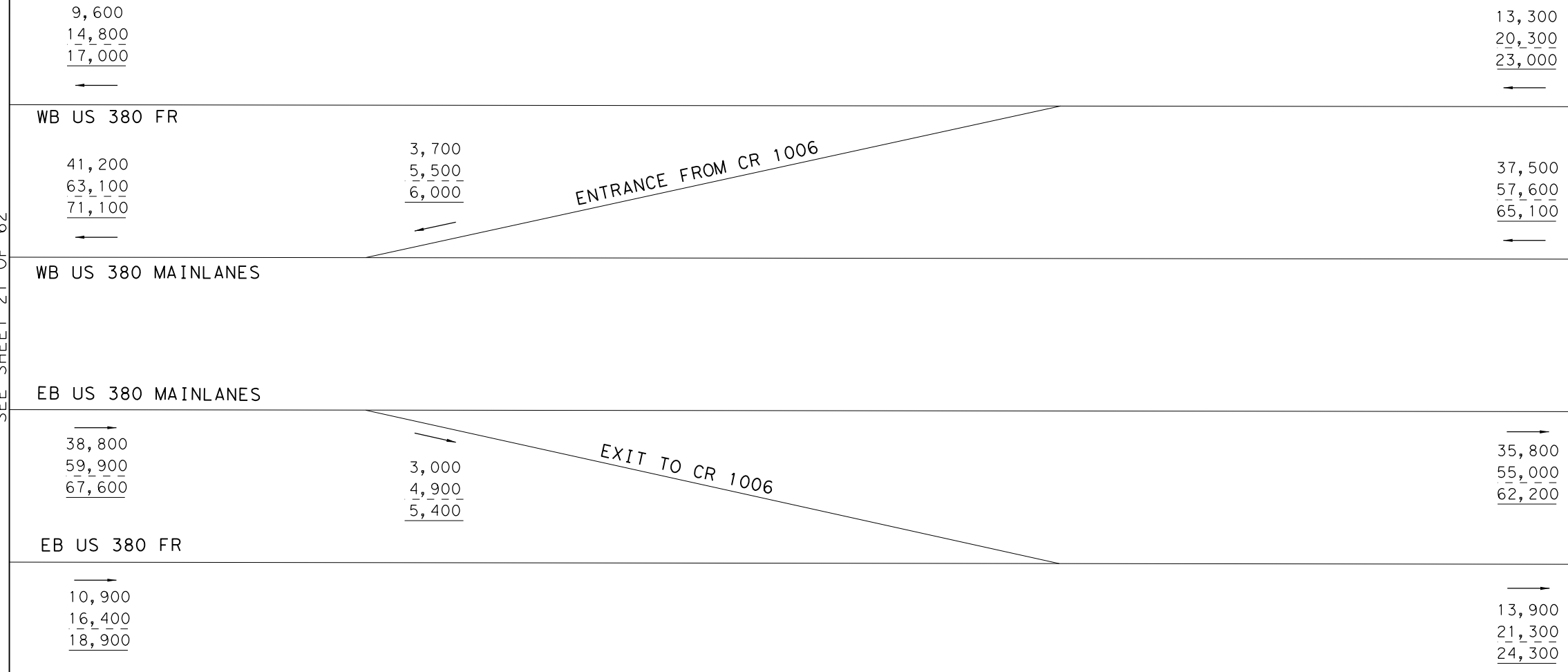
- XXXX- 2030 AVERAGE DAILY TRAFFIC VOLUMES
- XXXX- 2050 AVERAGE DAILY TRAFFIC VOLUMES
- XXXX- 2060 AVERAGE DAILY TRAFFIC VOLUMES

DATE: 7/13/2021
 FILE: US380_PURPLE_TRF_21.dgn



SEE SHEET 21 OF 62

SEE SHEET 23 OF 62



NOT TO SCALE

NOT INTENDED FOR CONSTRUCTION,
 BIDDING OR PERMIT PURPOSES
 DHRUVA LAHON, P.E.
 SERIAL NUMBER 102185

US 380 PURPLE ALT AND
 RAMPS
 AVERAGE DAILY TRAFFIC
 PURPLE ALT BUILD VOLUMES



0135-02-065,
 ETC. SHEET 22 OF 62

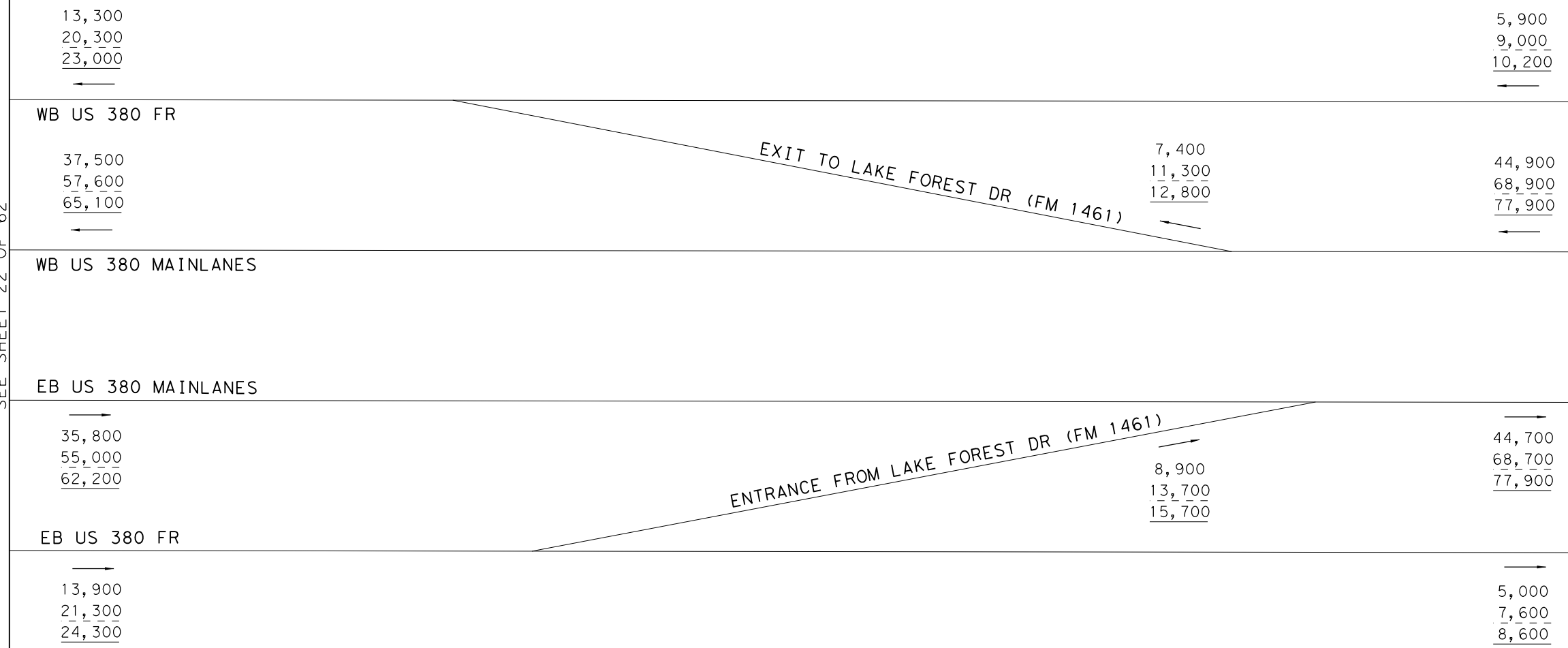
LEGEND

- XXXX- 2030 AVERAGE DAILY TRAFFIC VOLUMES
- XXXX- 2050 AVERAGE DAILY TRAFFIC VOLUMES
- XXXX- 2060 AVERAGE DAILY TRAFFIC VOLUMES



SEE SHEET 22 OF 62

SEE SHEET 24 OF 62



NOT TO SCALE

NOT INTENDED FOR CONSTRUCTION,
 BIDDING OR PERMIT PURPOSES
 DHRUVA LAHON, P.E.
 SERIAL NUMBER 102185

US 380 PURPLE ALT AND
 RAMPS
 AVERAGE DAILY TRAFFIC
 PURPLE ALT BUILD VOLUMES



0135-02-065,
 ETC. SHEET 23 OF 62

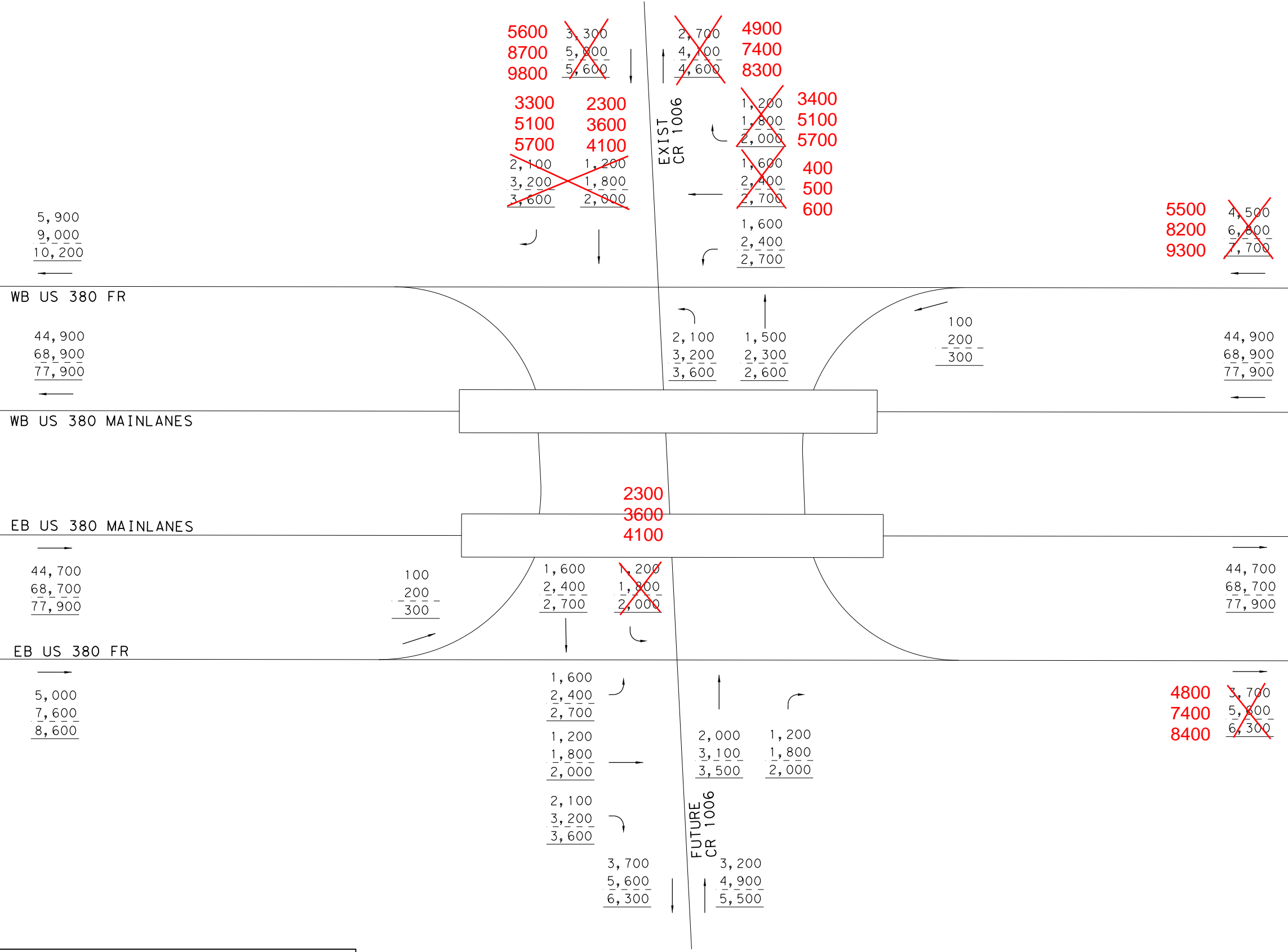
LEGEND

- XXXX- 2030 AVERAGE DAILY TRAFFIC VOLUMES
- XXXX- 2050 AVERAGE DAILY TRAFFIC VOLUMES
- XXXX- 2060 AVERAGE DAILY TRAFFIC VOLUMES



SEE SHEET 23 OF 62

SEE SHEET 25 OF 62



LEGEND

- XXXX- 2030 AVERAGE DAILY TRAFFIC VOLUMES
- XXXX- 2050 AVERAGE DAILY TRAFFIC VOLUMES
- XXXX- 2060 AVERAGE DAILY TRAFFIC VOLUMES

NOT TO SCALE

NOT INTENDED FOR CONSTRUCTION,
 BIDDING OR PERMIT PURPOSES
 DHRUVA LAHON, P.E.
 SERIAL NUMBER 102185

US 380 PURPLE ALT AND
 CR 1006
 AVERAGE DAILY TRAFFIC
 PURPLE ALT BUILD VOLUMES



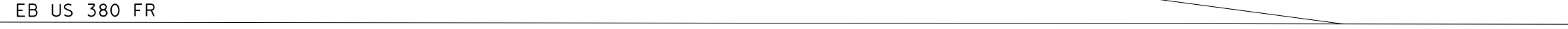
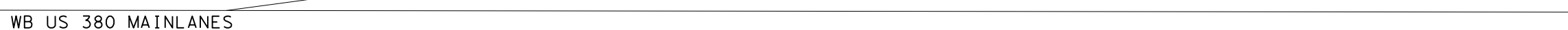
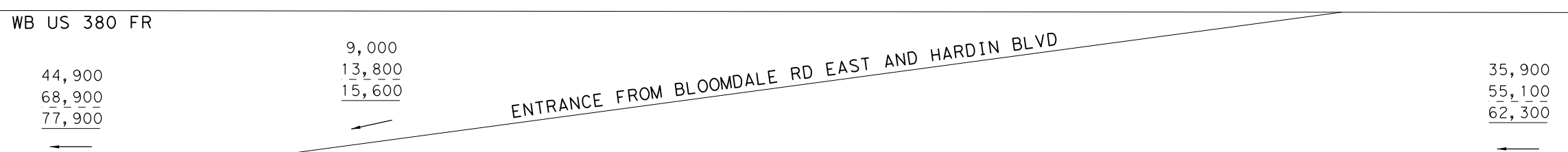


SEE SHEET 24 OF 62

SEE SHEET 26 OF 62

4,500	5500
6,800	8200
7,700	9300

14500	13,500
22000	20,600
24900	28,300



3,700	4800
5,600	7400
6,300	8400

13700	12,600
21100	19,300
24100	22,000

NOT TO SCALE

NOT INTENDED FOR CONSTRUCTION,
BIDDING OR PERMIT PURPOSES
DHURVA LAHON, P.E.
SERIAL NUMBER 102185

US 380 PURPLE ALT AND RAMP
AVERAGE DAILY TRAFFIC
PURPLE ALT BUILD VOLUMES



0135-02-065, ETC. SHEET 25 OF 62

LEGEND

- XXXX- 2030 AVERAGE DAILY TRAFFIC VOLUMES
- XXXX- 2050 AVERAGE DAILY TRAFFIC VOLUMES
- XXXX- 2060 AVERAGE DAILY TRAFFIC VOLUMES

DATE: 7/13/2021
FILE: US380_PURPLE_TRF_25.dgn



13,500	14500
20,600	22000
23,300	24900

WB US 380 FR

35,900
<u>55,100</u>
62,300

WB US 380 MAINLANES

EXIT TO CR 1006

2,300
<u>3,400</u>
3,700

12200	11,200
18600	17,800
21200	19,600

SEE SHEET 25 OF 62

EB US 380 MAINLANES

35,800
<u>55,000</u>
62,200

EB US 380 FR

ENTRANCE FROM CR 1006

2,000
<u>2,800</u>
3,100

12,600	13700
19,300	21100
22,000	24100

38,200
<u>58,500</u>
66,000

37,800
<u>57,800</u>
65,300

SEE SHEET 27 OF 62

11700	10,600
18300	16,500
21000	18,900

NOT TO SCALE

NOT INTENDED FOR CONSTRUCTION,
BIDDING OR PERMIT PURPOSES
DHURVA LAHON, P.E.
SERIAL NUMBER 102185

US 380 PURPLE ALT AND
RAMPS
AVERAGE DAILY TRAFFIC
PURPLE ALT BUILD VOLUMES

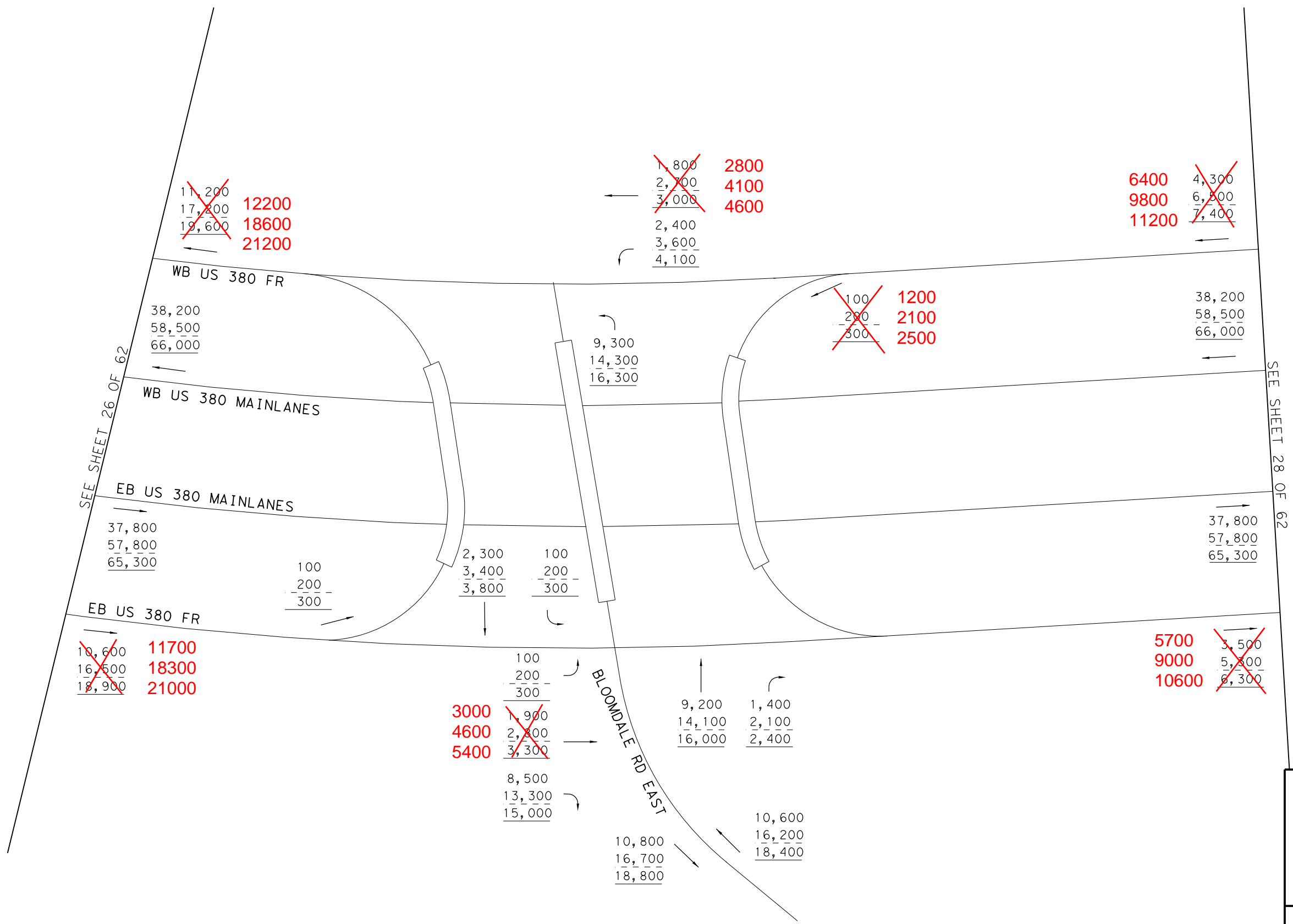
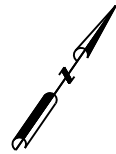
Kimley»Horn
F-928

0135-02-065,
ETC.

SHEET 26 OF 62

LEGEND

XXXX-	2030	AVERAGE	DAILY	TRAFFIC	VOLUMES
-XXXX-	2050	AVERAGE	DAILY	TRAFFIC	VOLUMES
<u>XXXX-</u>	2060	AVERAGE	DAILY	TRAFFIC	VOLUMES



SEE SHEET 26 OF 62

SEE SHEET 28 OF 62

NOT TO SCALE

NOT INTENDED FOR CONSTRUCTION,
BIDDING OR PERMIT PURPOSES
DHRUVA LAHON, P.E.
SERIAL NUMBER 102185

US 380 PURPLE ALT AND
E BLOOMDALE RD
AVERAGE DAILY TRAFFIC
PURPLE ALT BUILD VOLUMES

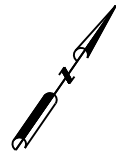
Kimley»Horn
F-928

0135-02-065,
ETC. SHEET 27 OF 62

LEGEND

- XXXX- 2030 AVERAGE DAILY TRAFFIC VOLUMES
- XXXX- 2050 AVERAGE DAILY TRAFFIC VOLUMES
- XXXX- 2060 AVERAGE DAILY TRAFFIC VOLUMES

DATE: 7/13/2021
FILE: US380_PURPLE_TRF_27.dgn



RD 201

2400
3700
4200
↓

2200
3300
3800
↑

2400
3700
4200
↓

2200
3300
3800
4000
6100
7000

~~4,300~~
~~6,500~~
~~7,400~~

~~4,300~~
~~6,500~~
~~7,400~~

6400
9800
11200

WB US 380 FR

38,200
58,500
66,000

38,200
58,500
66,000

WB US 380 MAINLANES

EB US 380 MAINLANES

37,800
57,800
65,300

37,800
57,800
65,300

EB US 380 FR

~~3,500~~
~~5,700~~
~~6,300~~

5700
9000
10600

5700
9000
10600

~~3,500~~
~~5,700~~
~~6,300~~

SEE SHEET 27 OF 62

SEE SHEET 29 OF 62

NOT TO SCALE

NOT INTENDED FOR CONSTRUCTION,
BIDDING OR PERMIT PURPOSES
DHURVA LAHON, P.E.
SERIAL NUMBER 102185

US 380 PURPLE ALT
AVERAGE DAILY TRAFFIC
PURPLE ALT BUILD VOLUMES

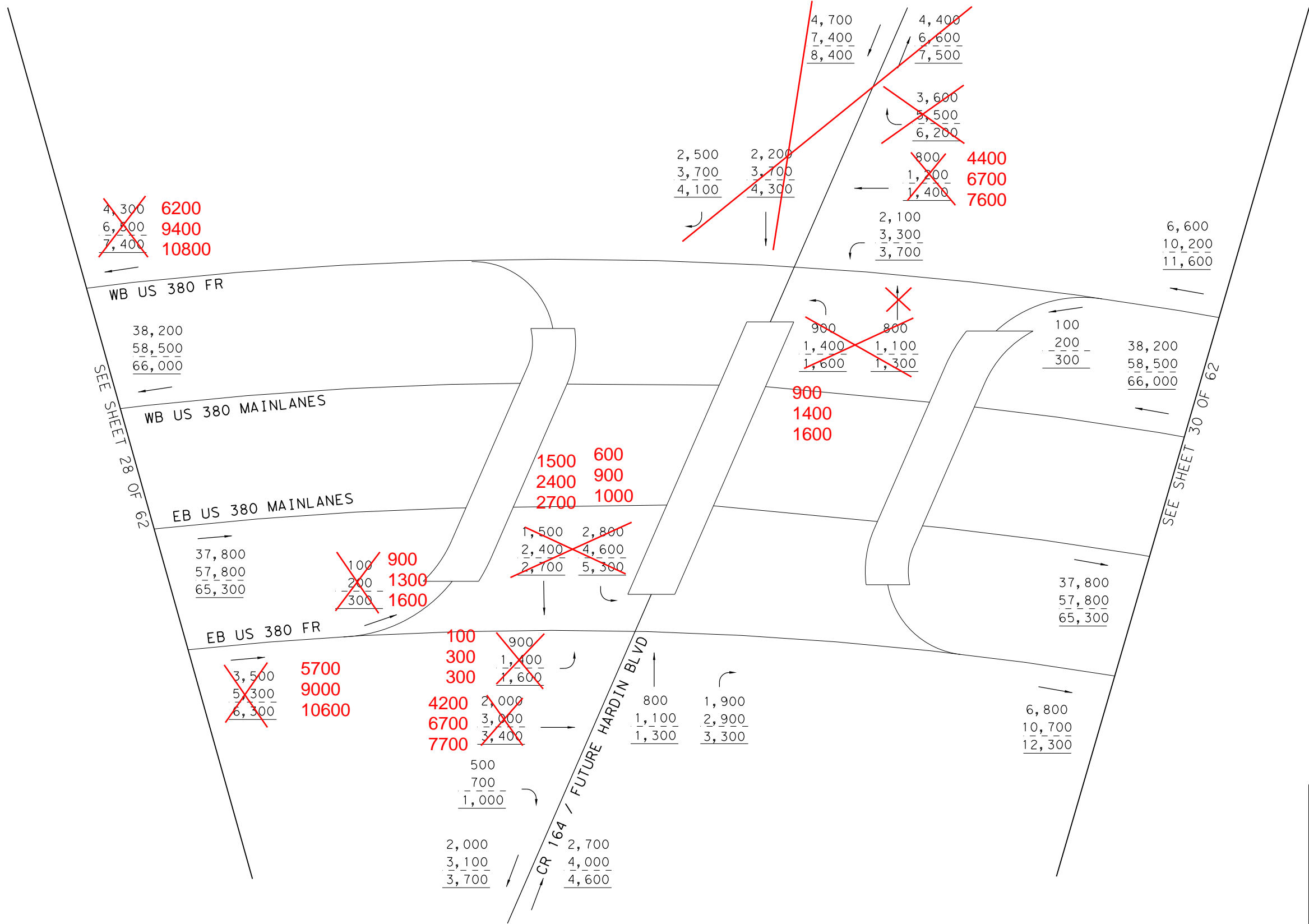
Kimley»Horn
F-928

0135-02-065,
ETC. SHEET 28 OF 62

LEGEND

- XXXX- 2030 AVERAGE DAILY TRAFFIC VOLUMES
- XXXX- 2050 AVERAGE DAILY TRAFFIC VOLUMES
- XXXX- 2060 AVERAGE DAILY TRAFFIC VOLUMES

DATE: 7/13/2021
FILE: US380_PURPLE_TRF_28.dgn



SEE SHEET 28 OF 62

SEE SHEET 30 OF 62

NOT TO SCALE

NOT INTENDED FOR CONSTRUCTION,
 BIDDING OR PERMIT PURPOSES
 DHRUVA LAHON, P.E.
 SERIAL NUMBER 102185

US 380 PURPLE ALT AND
 CR 164
 AVERAGE DAILY TRAFFIC
 PURPLE ALT BUILD VOLUMES

Kimley»Horn
F-928

0135-02-065,
 ETC. SHEET 29 OF 62

LEGEND

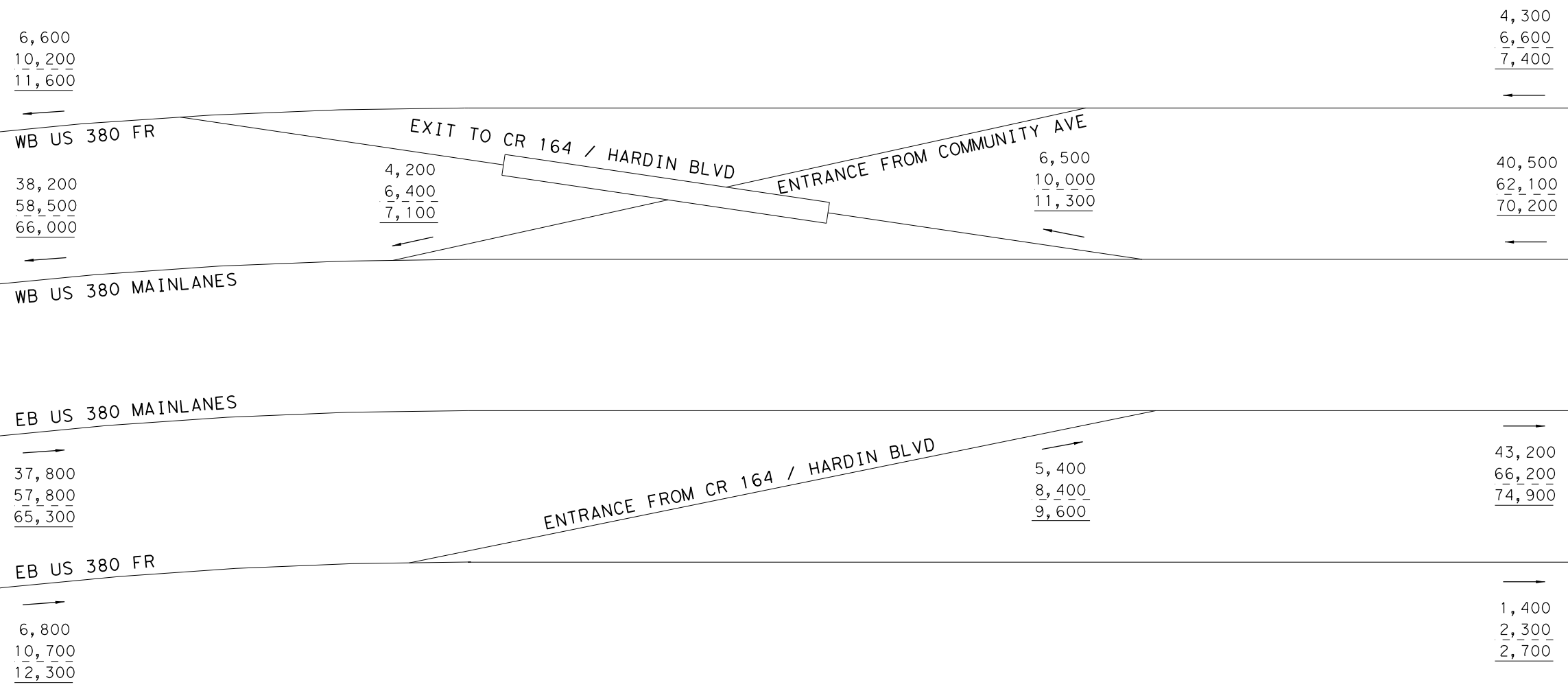
- XXXX- 2030 AVERAGE DAILY TRAFFIC VOLUMES
- XXXX- 2050 AVERAGE DAILY TRAFFIC VOLUMES
- XXXX- 2060 AVERAGE DAILY TRAFFIC VOLUMES

DATE: 7/13/2021
 FILE: US380_PURPLE_TRF_29.dgn



SEE SHEET 29 OF 62

SEE SHEET 31 OF 62



LEGEND

- XXXX- 2030 AVERAGE DAILY TRAFFIC VOLUMES
- XXXX- 2050 AVERAGE DAILY TRAFFIC VOLUMES
- XXXX- 2060 AVERAGE DAILY TRAFFIC VOLUMES

NOT TO SCALE

NOT INTENDED FOR CONSTRUCTION,
 BIDDING OR PERMIT PURPOSES
 DHRUVA LAHON, P.E.
 SERIAL NUMBER 102185

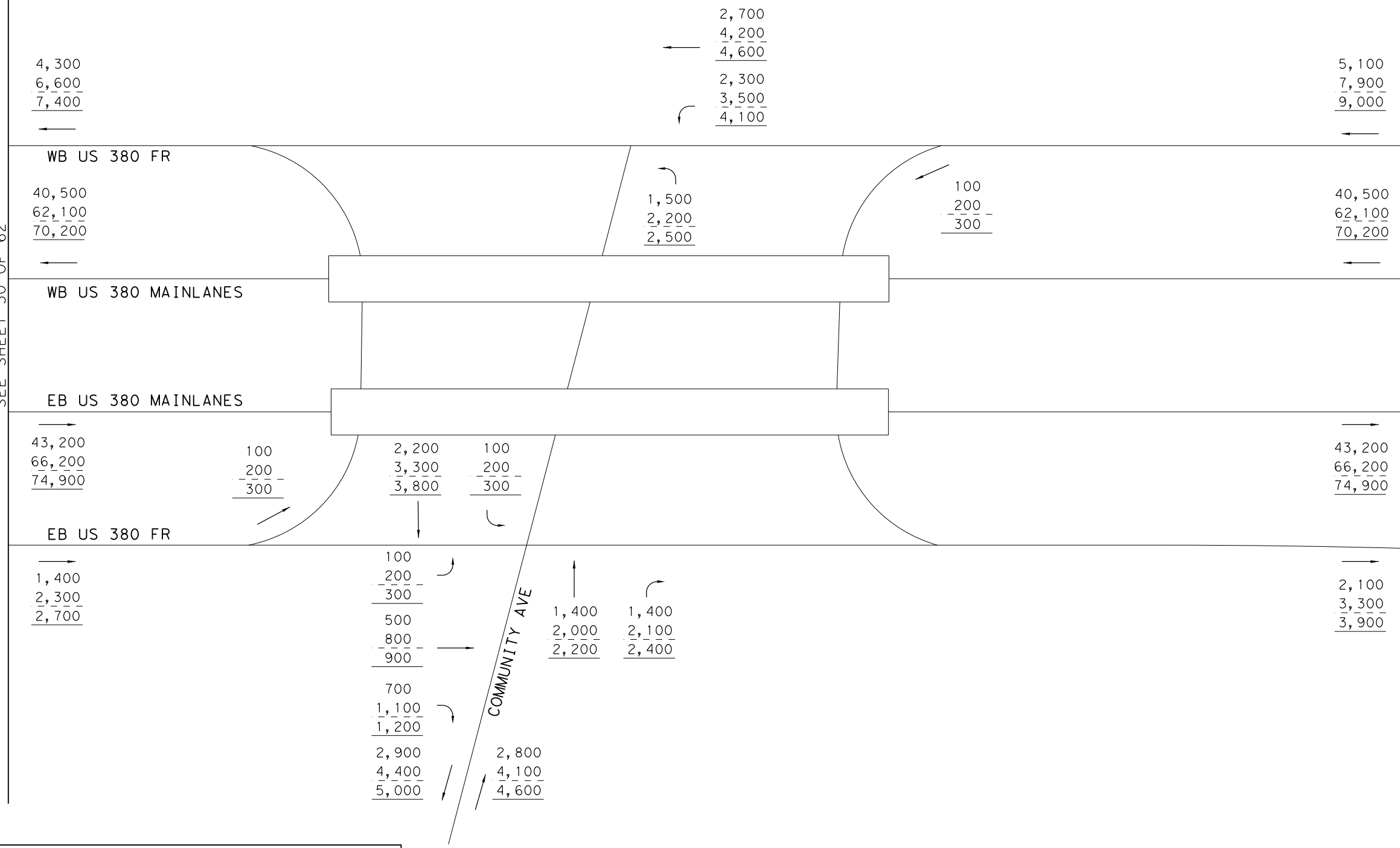
US 380 PURPLE ALT AND
 RAMPS
 AVERAGE DAILY TRAFFIC
 PURPLE ALT BUILD VOLUMES





SEE SHEET 30 OF 62

SEE SHEET 32 OF 62



NOT TO SCALE

NOT INTENDED FOR CONSTRUCTION,
BIDDING OR PERMIT PURPOSES
DHURVA LAHON, P.E.
SERIAL NUMBER 102185

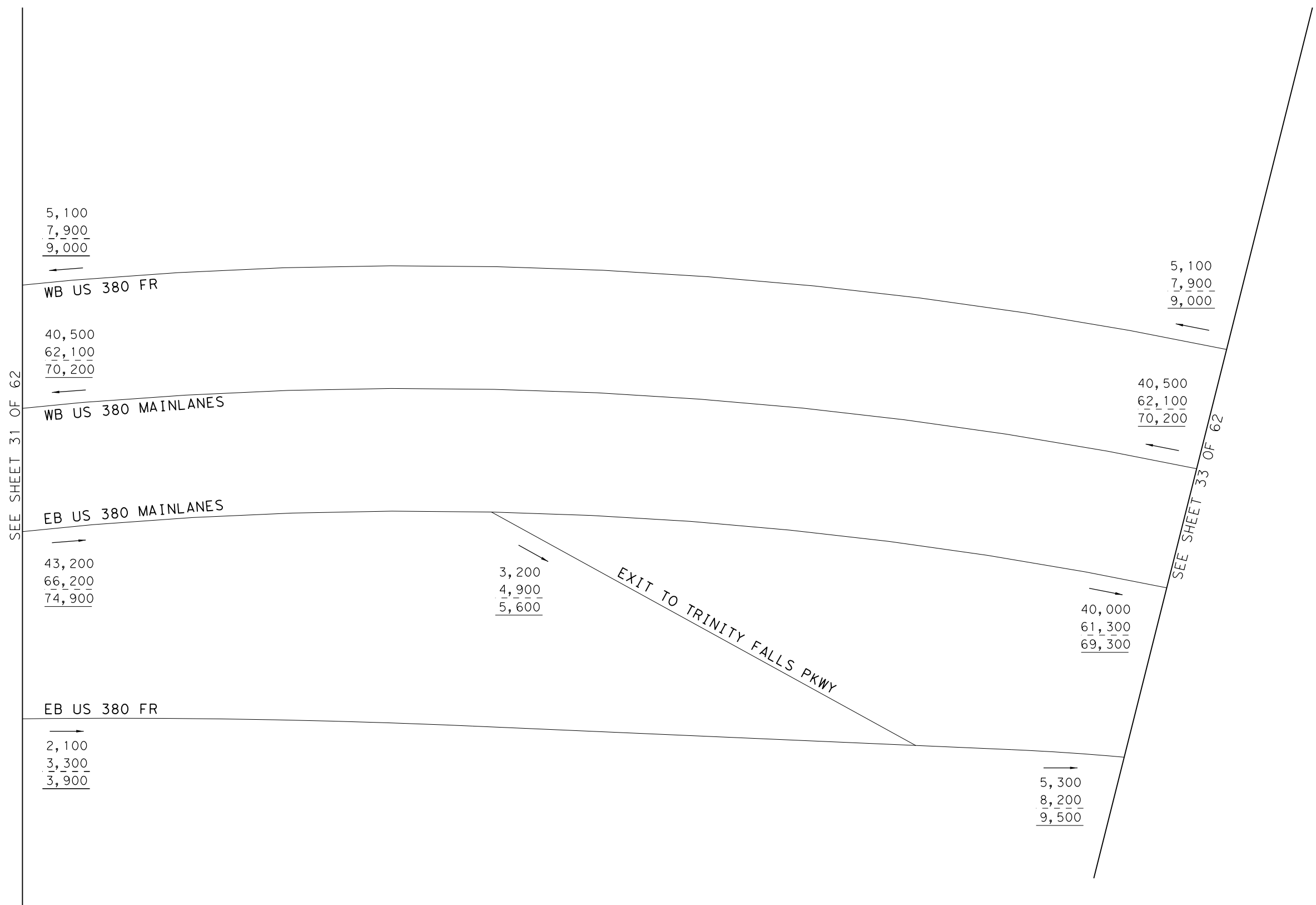
US 380 PURPLE ALT AND
COMMUNITY AVE
AVERAGE DAILY TRAFFIC
PURPLE ALT BUILD VOLUMES



0135-02-065,
ETC. SHEET 31 OF 62

LEGEND

- XXXX- 2030 AVERAGE DAILY TRAFFIC VOLUMES
- XXXX- 2050 AVERAGE DAILY TRAFFIC VOLUMES
- XXXX- 2060 AVERAGE DAILY TRAFFIC VOLUMES



5,100
7,900
9,000

5,100
7,900
9,000

40,500
62,100
70,200

40,500
62,100
70,200

43,200
66,200
74,900

3,200
4,900
5,600

40,000
61,300
69,300

2,100
3,300
3,900

5,300
8,200
9,500

NOT TO SCALE

NOT INTENDED FOR CONSTRUCTION,
 BIDDING OR PERMIT PURPOSES
 DHRUVA LAHON, P.E.
 SERIAL NUMBER 102185

US 380 PURPLE ALT AND
 RAMPS
 AVERAGE DAILY TRAFFIC
 PURPLE ALT BUILD VOLUMES

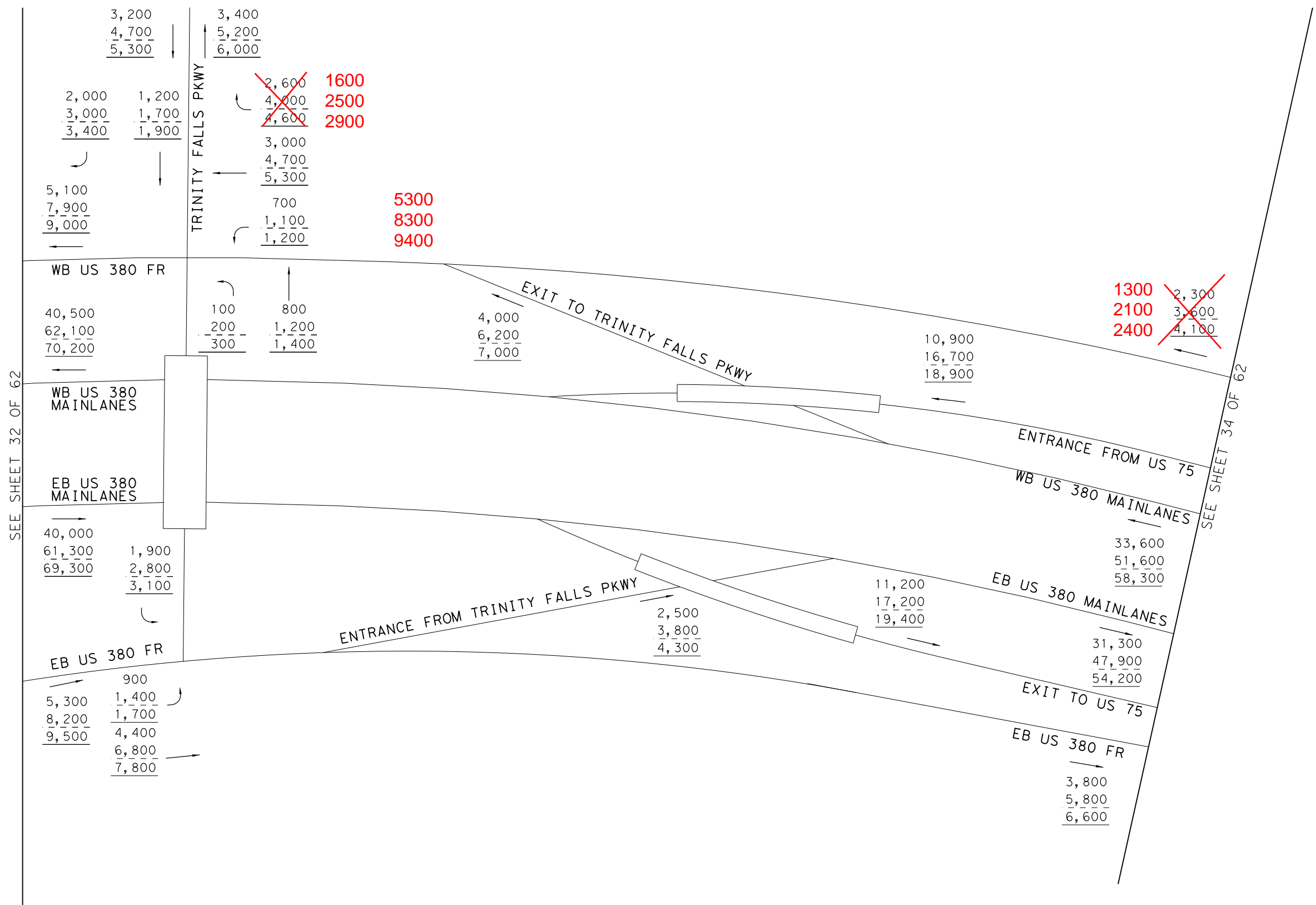
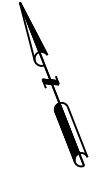
Kimley»Horn
F-928

0135-02-065,
 ETC. SHEET 32 OF 62

LEGEND

- XXXX- 2030 AVERAGE DAILY TRAFFIC VOLUMES
- XXXX- 2050 AVERAGE DAILY TRAFFIC VOLUMES
- XXXX- 2060 AVERAGE DAILY TRAFFIC VOLUMES

DATE: 7/13/2021
 FILE: US380_PURPLE_TRF_32.dgn



SEE SHEET 32 OF 62

SEE SHEET 34 OF 62

LEGEND

- XXXX- 2030 AVERAGE DAILY TRAFFIC VOLUMES
- XXXX- 2050 AVERAGE DAILY TRAFFIC VOLUMES
- XXXX- 2060 AVERAGE DAILY TRAFFIC VOLUMES

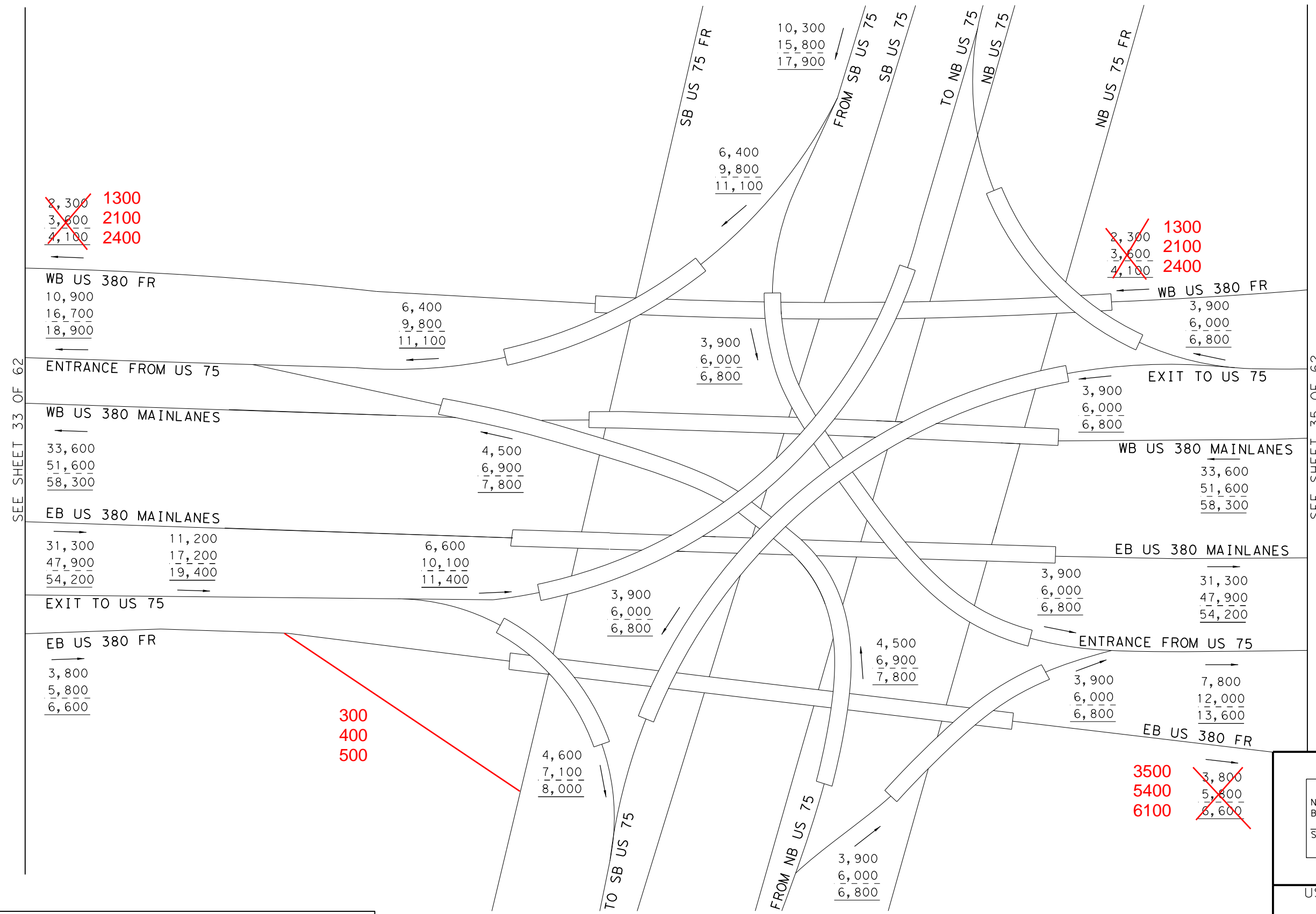
NOT TO SCALE

NOT INTENDED FOR CONSTRUCTION,
BIDDING OR PERMIT PURPOSES
DHURVA LAHON, P.E.
SERIAL NUMBER 102185

US 380 PURPLE ALT AND
TRINITY FALLS PKWY
AVERAGE DAILY TRAFFIC
PURPLE ALT BUILD VOLUMES



DATE: 7/13/2021
FILE: US380_PURPLE_TRF_33.dgn



~~2,300~~ 1300
~~3,600~~ 2100
~~4,100~~ 2400

~~2,300~~ 1300
~~3,600~~ 2100
~~4,100~~ 2400

300
400
500

~~3,800~~
~~5,800~~
~~6,600~~
3500
5400
6100

SEE SHEET 33 OF 62

SEE SHEET 35 OF 62

NOT TO SCALE

NOT INTENDED FOR CONSTRUCTION,
BIDDING OR PERMIT PURPOSES
DHURVA LAHON, P.E.
SERIAL NUMBER 102185

US 380 PURPLE ALT AND
IH 75
AVERAGE DAILY TRAFFIC
PURPLE ALT BUILD VOLUMES

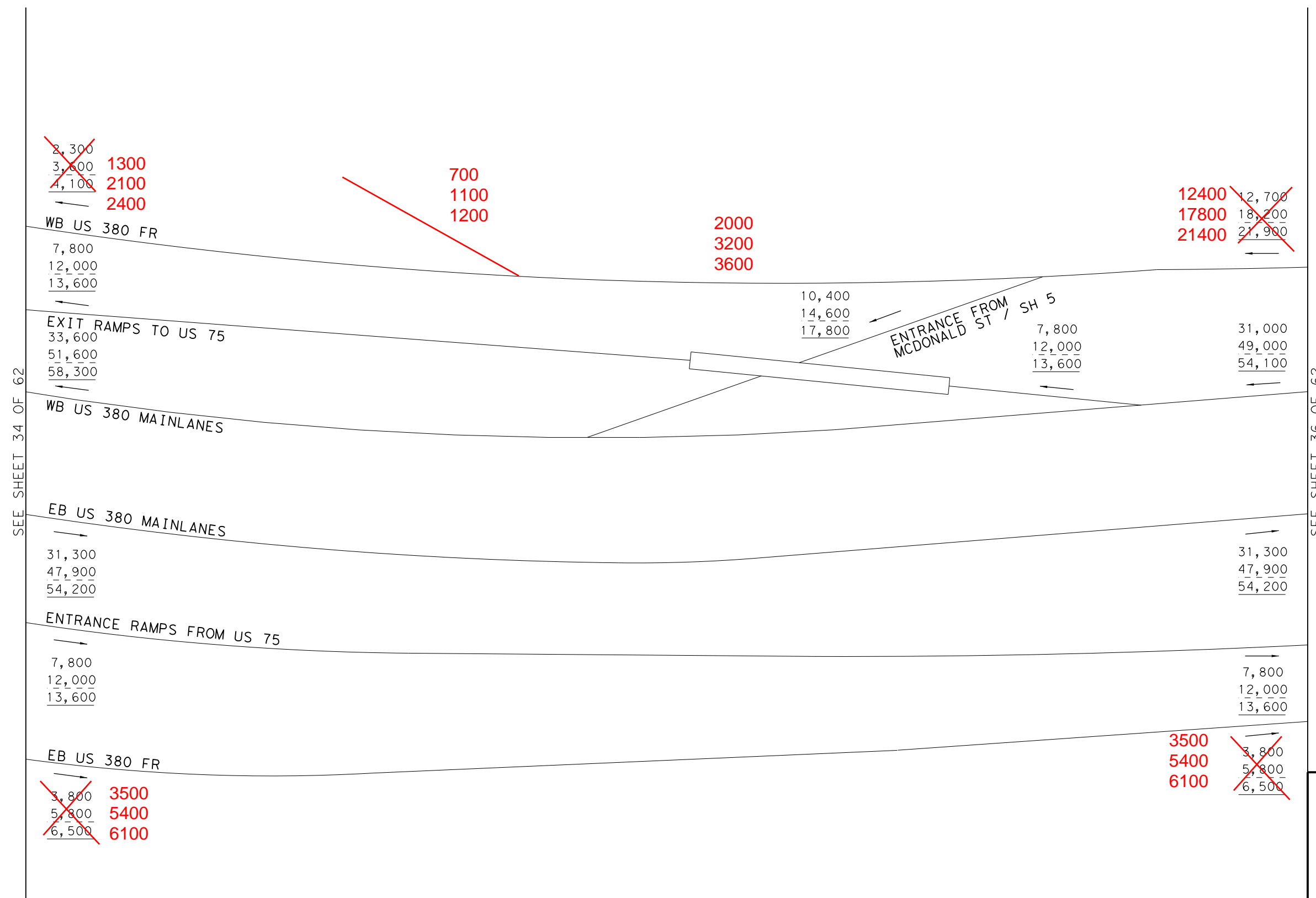
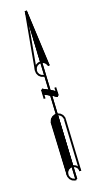
Kimley»Horn
F-928

0135-02-065,
ETC. SHEET 34 OF 62

LEGEND

- XXXX- 2030 AVERAGE DAILY TRAFFIC VOLUMES
- XXXX- 2050 AVERAGE DAILY TRAFFIC VOLUMES
- XXXX- 2060 AVERAGE DAILY TRAFFIC VOLUMES

DATE: 7/13/2021
FILE: US380_PURPLE_TRF_34.dgn



SEE SHEET 34 OF 62

SEE SHEET 36 OF 62

NOT TO SCALE

NOT INTENDED FOR CONSTRUCTION,
 BIDDING OR PERMIT PURPOSES
 DHRUVA LAHON, P.E.
 SERIAL NUMBER 102185

US 380 PURPLE ALT AND
 WESTON RD
 AVERAGE DAILY TRAFFIC
 PURPLE ALT BUILD VOLUMES



0135-02-065,
 ETC. SHEET 35 OF 62

LEGEND

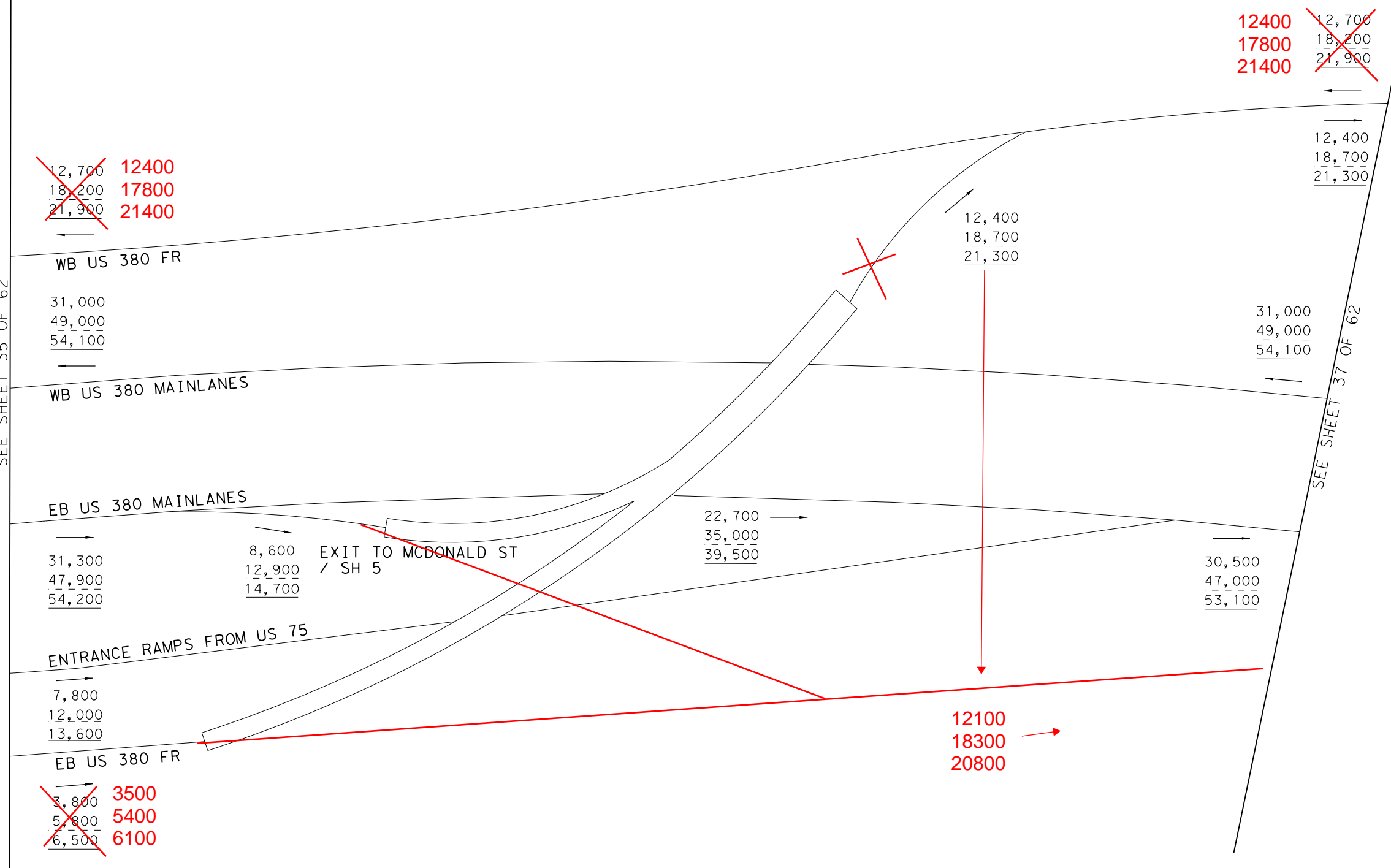
- XXXX- 2030 AVERAGE DAILY TRAFFIC VOLUMES
- XXXX- 2050 AVERAGE DAILY TRAFFIC VOLUMES
- XXXX- 2060 AVERAGE DAILY TRAFFIC VOLUMES

DATE: 7/13/2021
 FILE: US380_PURPLE_TRF_35.dgn



SEE SHEET 35 OF 62

SEE SHEET 37 OF 62



~~12,700~~ 12400
~~18,200~~ 17800
~~21,900~~ 21400

12400
 17800
 21400

~~12,700~~
~~18,200~~
~~21,900~~

31,000
 49,000
 54,100

31,000
 49,000
 54,100

31,300
 47,900
 54,200

8,600
 12,900
 14,700

22,700
 35,000
 39,500

30,500
 47,000
 53,100

7,800
 12,000
 13,600

~~3,800~~ 3500
~~5,800~~ 5400
~~6,500~~ 6100

12100
 18300
 20800

12,400
 18,700
 21,300

LEGEND

- XXXX- 2030 AVERAGE DAILY TRAFFIC VOLUMES
- XXXX- 2050 AVERAGE DAILY TRAFFIC VOLUMES
- XXXX- 2060 AVERAGE DAILY TRAFFIC VOLUMES

NOT TO SCALE

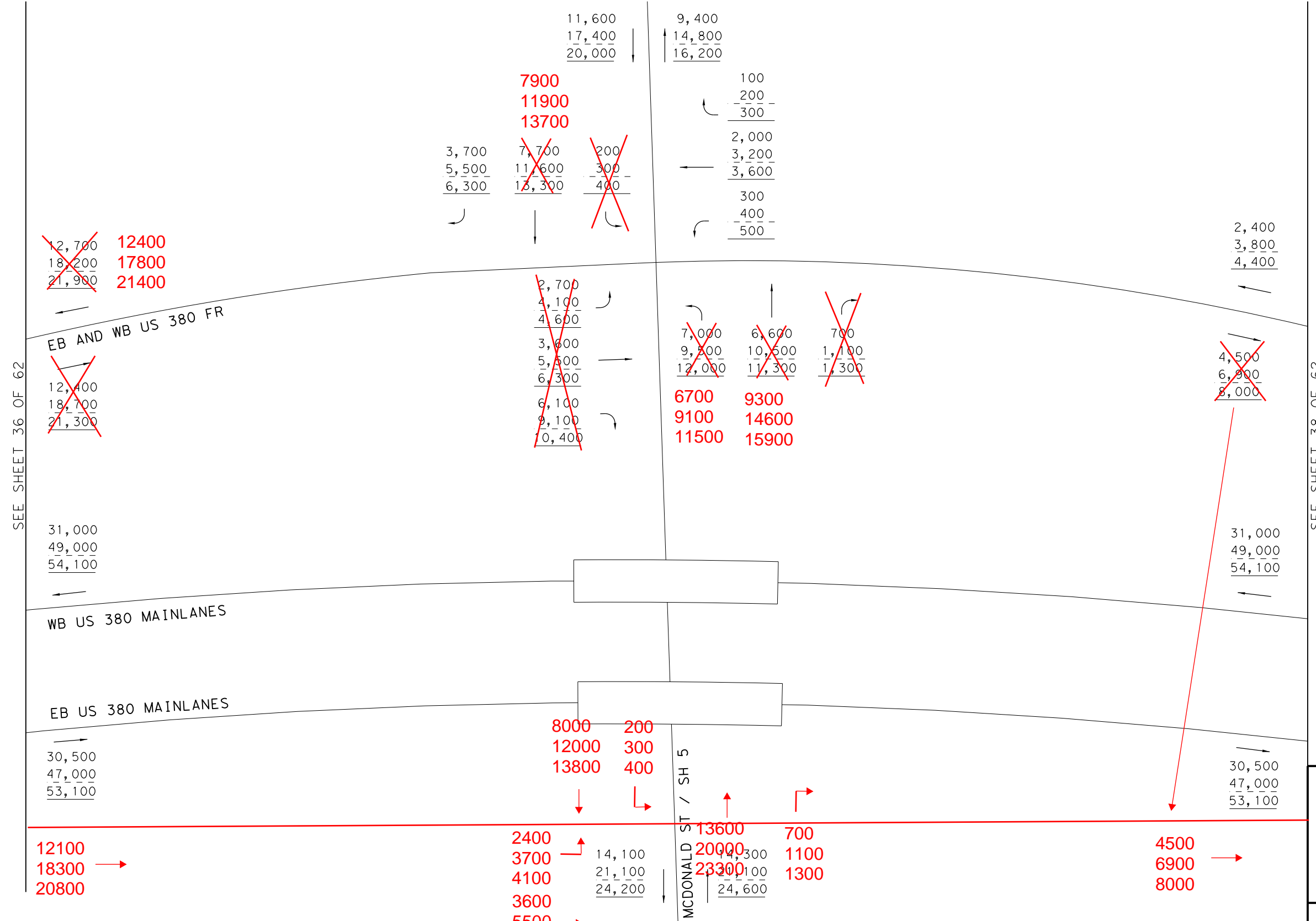
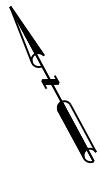
NOT INTENDED FOR CONSTRUCTION,
 BIDDING OR PERMIT PURPOSES
 DHRUVA LAHON, P.E.
 SERIAL NUMBER 102185

US 380 PURPLE ALT AND
 RAMPS
 AVERAGE DAILY TRAFFIC
 PURPLE ALT BUILD VOLUMES



0135-02-065,
 ETC. SHEET 36 OF 62

DATE: 7/13/2021
 FILE: US380_PURPLE_TRF_36.dgn



SEE SHEET 36 OF 62

SEE SHEET 38 OF 62

NOT TO SCALE

NOT INTENDED FOR CONSTRUCTION,
 BIDDING OR PERMIT PURPOSES
 DHRUVA LAHON, P.E.
 SERIAL NUMBER 102185

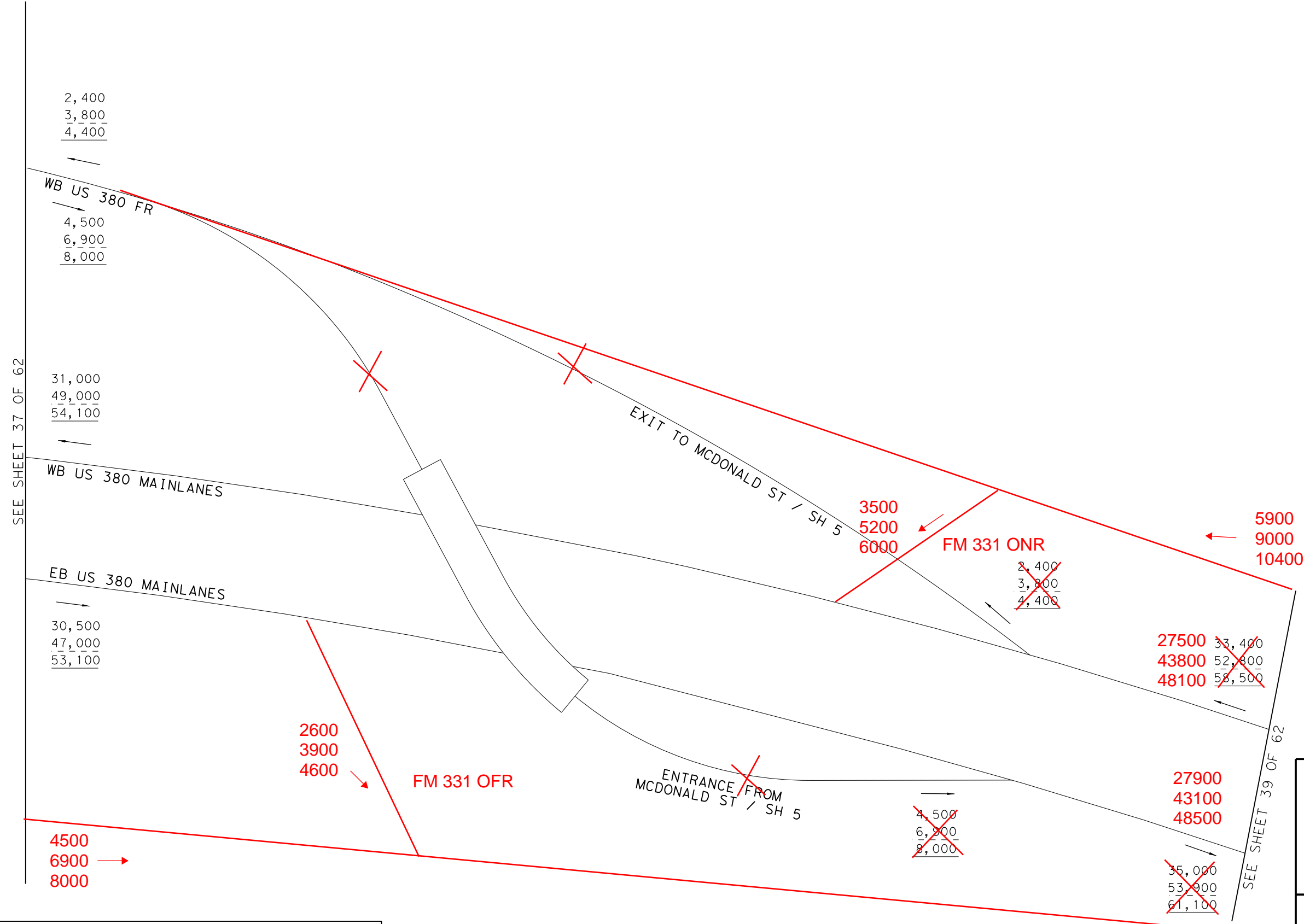
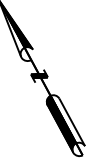
US 380 PURPLE ALT AND
 MCDONALD ST / SH 5
 AVERAGE DAILY TRAFFIC
 PURPLE ALT BUILD VOLUMES

Kimley»Horn
 F-928

0135-02-065,
 ETC. SHEET 37 OF 62

LEGEND	
XXXX-	2030 AVERAGE DAILY TRAFFIC VOLUMES
-XXXX-	2050 AVERAGE DAILY TRAFFIC VOLUMES
XXXX-	2060 AVERAGE DAILY TRAFFIC VOLUMES

DATE: 7/13/2021
 FILE: US380_PURPLE_TRF_37.dgn



SEE SHEET 37 OF 62

SEE SHEET 39 OF 62

2,400
3,800
4,400

4,500
6,900
8,000

31,000
49,000
54,100

WB US 380 MAINLANES

EB US 380 MAINLANES

30,500
47,000
53,100

2600
3900
4600

FM 331 OFR

ENTRANCE FROM
MCDONALD ST / SH 5

3500
5200
6000

FM 331 ONR

~~2,400~~
~~3,800~~
~~4,400~~

5900
9000
10400

~~33,400~~
~~52,800~~
~~58,500~~

27900
43100
48500

~~35,000~~
~~53,900~~
~~61,100~~

~~4,500~~
~~6,900~~
~~8,000~~

7100
10800
12600

4500
6900
8000

LEGEND

- XXXX- 2030 AVERAGE DAILY TRAFFIC VOLUMES
- XXXX- 2050 AVERAGE DAILY TRAFFIC VOLUMES
- XXXX- 2060 AVERAGE DAILY TRAFFIC VOLUMES

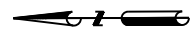
NOT TO SCALE

NOT INTENDED FOR CONSTRUCTION,
BIDDING OR PERMIT PURPOSES
DHURVA LAHON, P.E.
SERIAL NUMBER 102185

US 380 PURPLE ALT AND
RAMPS
AVERAGE DAILY TRAFFIC
PURPLE ALT BUILD VOLUMES

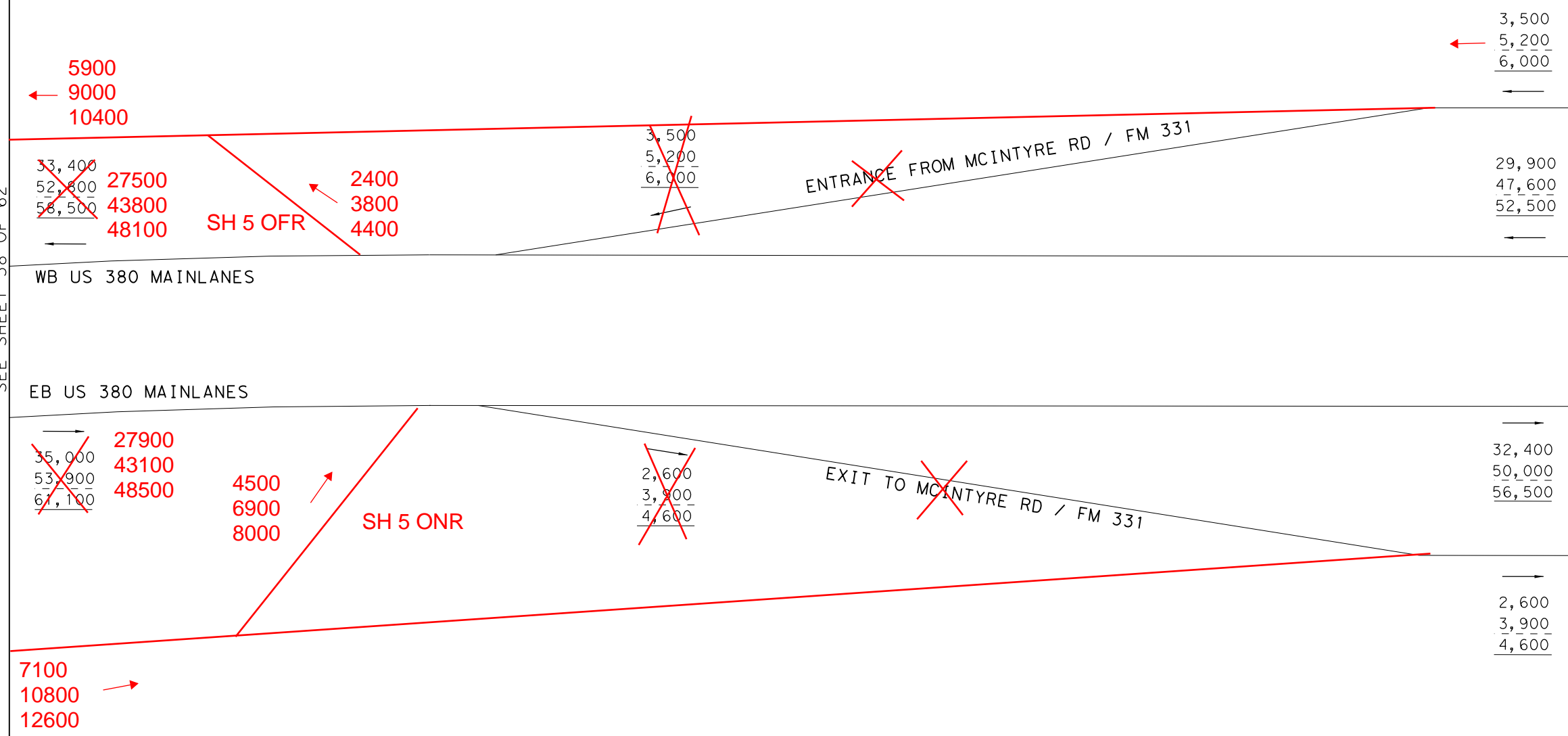


DATE: 7/13/2021
FILE: US380_PURPLE_TRF_38.dgn



SEE SHEET 38 OF 62

SEE SHEET 40 OF 62



WB US 380 MAINLANES

EB US 380 MAINLANES

ENTRANCE FROM MCINTYRE RD / FM 331

EXIT TO MCINTYRE RD / FM 331

SH 5 OFR

SH 5 ONR

NOT TO SCALE

NOT INTENDED FOR CONSTRUCTION,
 BIDDING OR PERMIT PURPOSES
 DHRUVA LAHON, P.E.
 SERIAL NUMBER 102185

US 380 PURPLE ALT AND
 RAMPS
 AVERAGE DAILY TRAFFIC
 PURPLE ALT BUILD VOLUMES

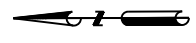


0135-02-065,
 ETC. SHEET 39 OF 62

LEGEND

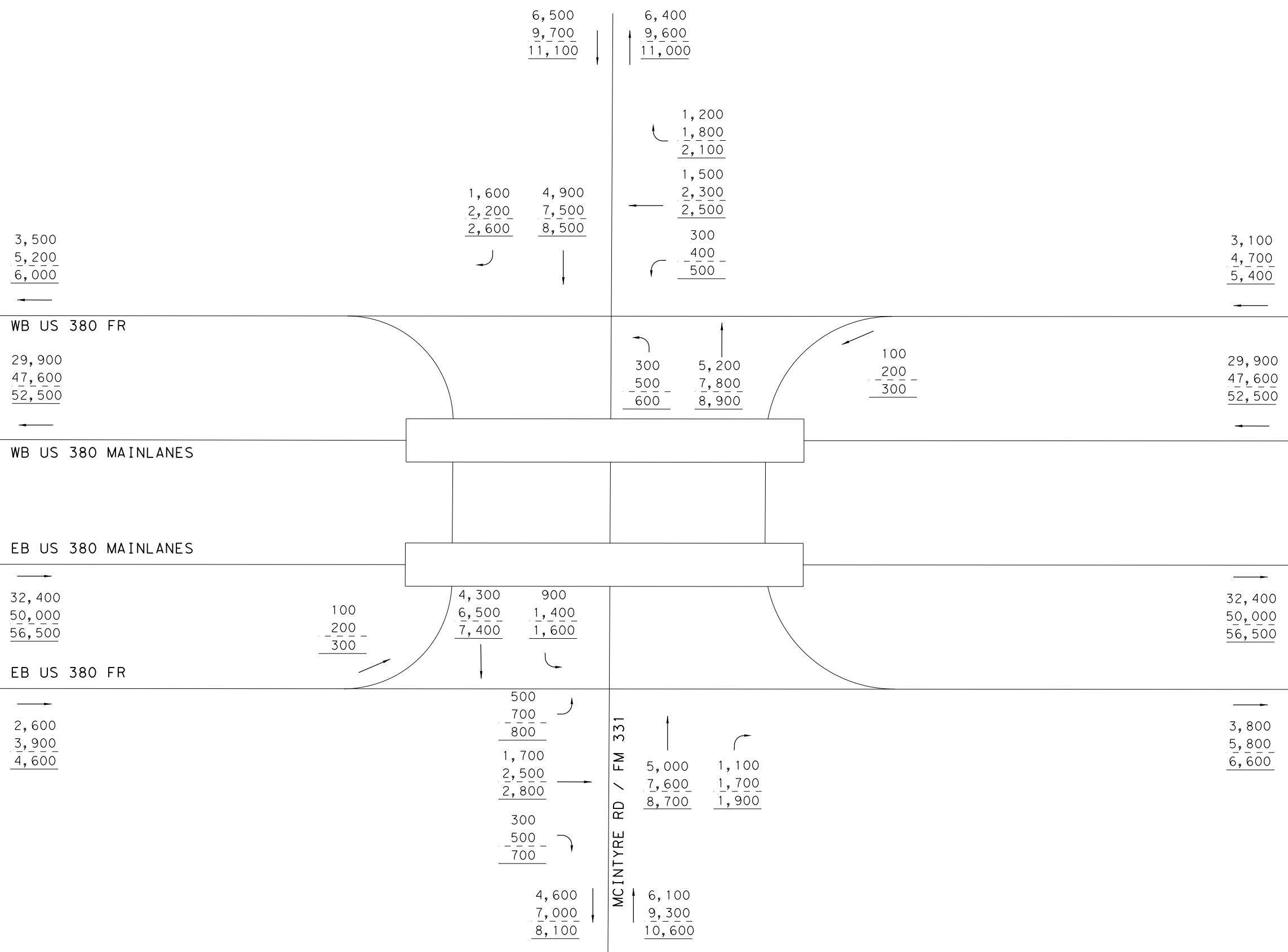
- XXXX- 2030 AVERAGE DAILY TRAFFIC VOLUMES
- XXXX- 2050 AVERAGE DAILY TRAFFIC VOLUMES
- XXXX- 2060 AVERAGE DAILY TRAFFIC VOLUMES

DATE: 7/13/2021
FILE: US380_PURPLE_TRF_39.dgn



SEE SHEET 39 OF 62

SEE SHEET 41 OF 62



NOT TO SCALE

NOT INTENDED FOR CONSTRUCTION,
BIDDING OR PERMIT PURPOSES
DHURVA LAHON, P.E.
SERIAL NUMBER 102185

US 380 PURPLE ALT AND
MCINTYRE RD/ CR 274
AVERAGE DAILY TRAFFIC
PURPLE ALT BUILD VOLUMES

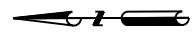


0135-02-065,
ETC. SHEET 40 OF 62

LEGEND

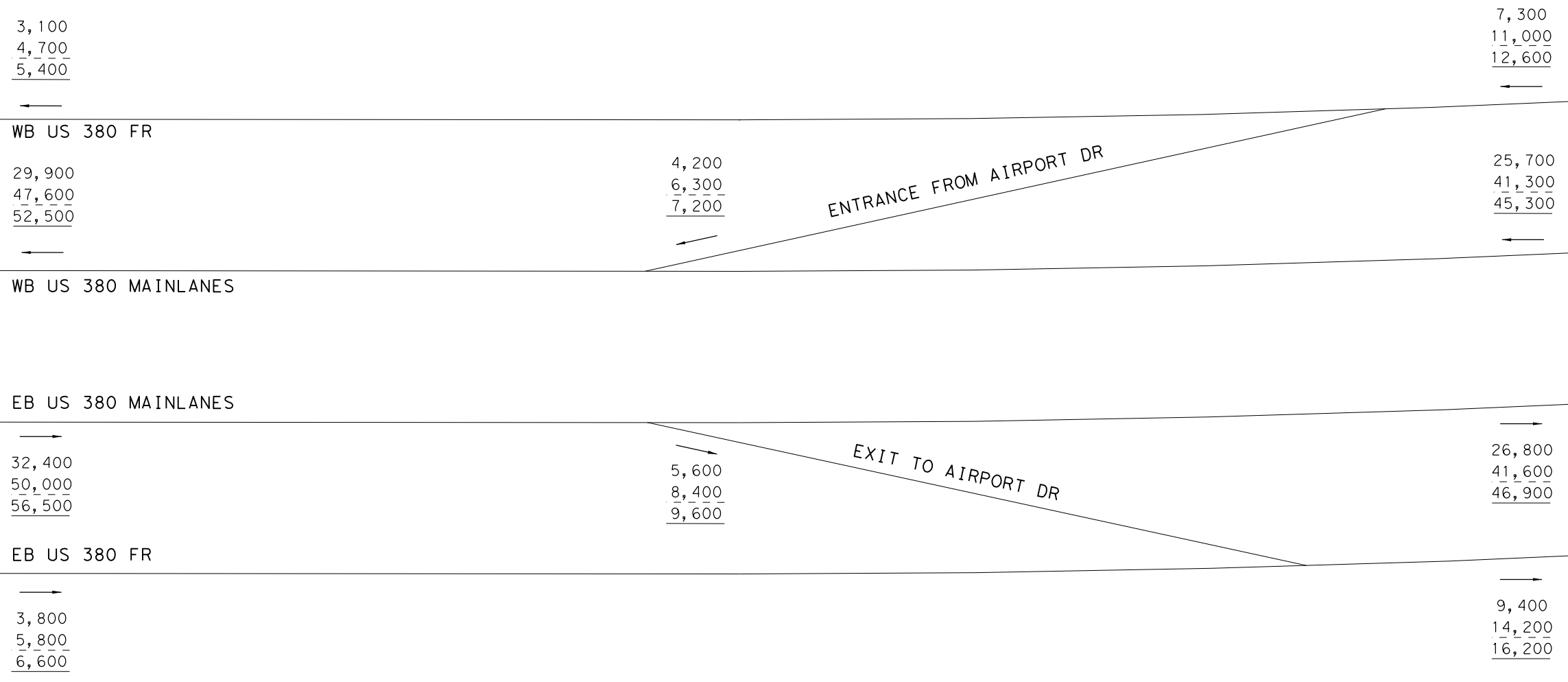
- XXXX- 2030 AVERAGE DAILY TRAFFIC VOLUMES
- XXXX- 2050 AVERAGE DAILY TRAFFIC VOLUMES
- XXXX- 2060 AVERAGE DAILY TRAFFIC VOLUMES

DATE: 7/13/2021
FILE: US380_PURPLE_TRF_40.dgn



SEE SHEET 40 OF 62

SEE SHEET 42 OF 62



NOT TO SCALE

NOT INTENDED FOR CONSTRUCTION,
 BIDDING OR PERMIT PURPOSES
 DHRUVA LAHON, P.E.
 SERIAL NUMBER 102185

US 380 PURPLE ALT AND
 RAMPS
 AVERAGE DAILY TRAFFIC
 PURPLE ALT BUILD VOLUMES

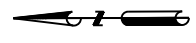


0135-02-065,
 ETC. SHEET 41 OF 62

LEGEND

- XXXX- 2030 AVERAGE DAILY TRAFFIC VOLUMES
- XXXX- 2050 AVERAGE DAILY TRAFFIC VOLUMES
- XXXX- 2060 AVERAGE DAILY TRAFFIC VOLUMES

DATE: 7/13/2021
 FILE: US380_PURPLE_TRF_41.dgn



7,300
11,000
12,600

WB US 380 FR

25,700
41,300
45,300

WB US 380 MAINLANES

EB US 380 MAINLANES

26,800
41,600
46,900

EB US 380 FR

9,400
14,200
16,200

~~4,600~~
~~6,900~~
~~7,900~~
7300
11000
12600

~~2,700~~
~~4,100~~
~~4,700~~
EXIT TO MCINTYRE RD / FM 331

25700
41300
45300

ENTRANCE FROM MCINTYRE RD / FM 331

~~4,300~~
~~6,500~~
~~7,200~~
3400
4900
5700

~~31,100~~
~~47,900~~
~~54,100~~
30200
46500
52600

~~5,100~~
~~7,900~~
~~9,000~~
6000
9300
10500

SEE SHEET 41 OF 62

SEE SHEET 43 OF 62

NOT TO SCALE

NOT INTENDED FOR CONSTRUCTION,
BIDDING OR PERMIT PURPOSES
DHURVA LAHON, P.E.
SERIAL NUMBER 102185

US 380 PURPLE ALT AND
RAMPS
AVERAGE DAILY TRAFFIC
PURPLE ALT BUILD VOLUMES

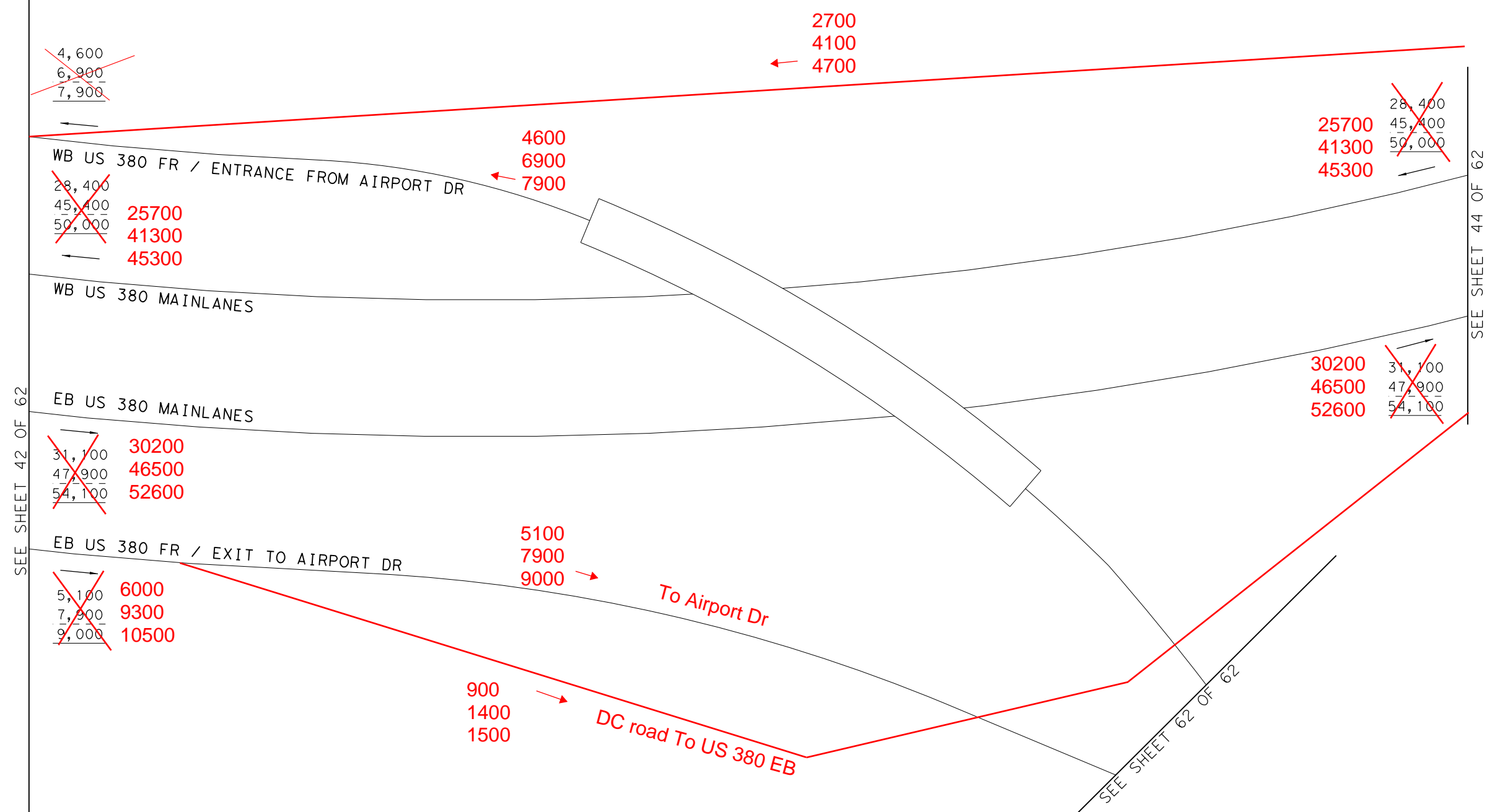
Kimley»Horn
F-928

0135-02-065,
ETC. SHEET 42 OF 62

LEGEND

- XXXX- 2030 AVERAGE DAILY TRAFFIC VOLUMES
- XXXX- 2050 AVERAGE DAILY TRAFFIC VOLUMES
- XXXX- 2060 AVERAGE DAILY TRAFFIC VOLUMES

DATE: 7/13/2021
FILE: US380_PURPLE_TRF_42.dgn



~~4,600~~
~~6,900~~
~~7,900~~

2700
 4100
 4700

25700
 41300
 45300

~~28,400~~
~~45,400~~
~~50,000~~

~~28,400~~
~~45,400~~
~~50,000~~

25700
 41300
 45300

4600
 6900
 7900

30200
 46500
 52600

~~31,100~~
~~47,900~~
~~54,100~~

~~31,100~~
~~47,900~~
~~54,100~~

30200
 46500
 52600

5100
 7900
 9000

~~5,100~~
~~7,900~~
~~9,000~~

6000
 9300
 10500

900
 1400
 1500

NOT TO SCALE

NOT INTENDED FOR CONSTRUCTION,
 BIDDING OR PERMIT PURPOSES
 DHRUVA LAHON, P.E.
 SERIAL NUMBER 102185

US 380 PURPLE ALT AND
 RAMPS
 AVERAGE DAILY TRAFFIC
 PURPLE ALT BUILD VOLUMES

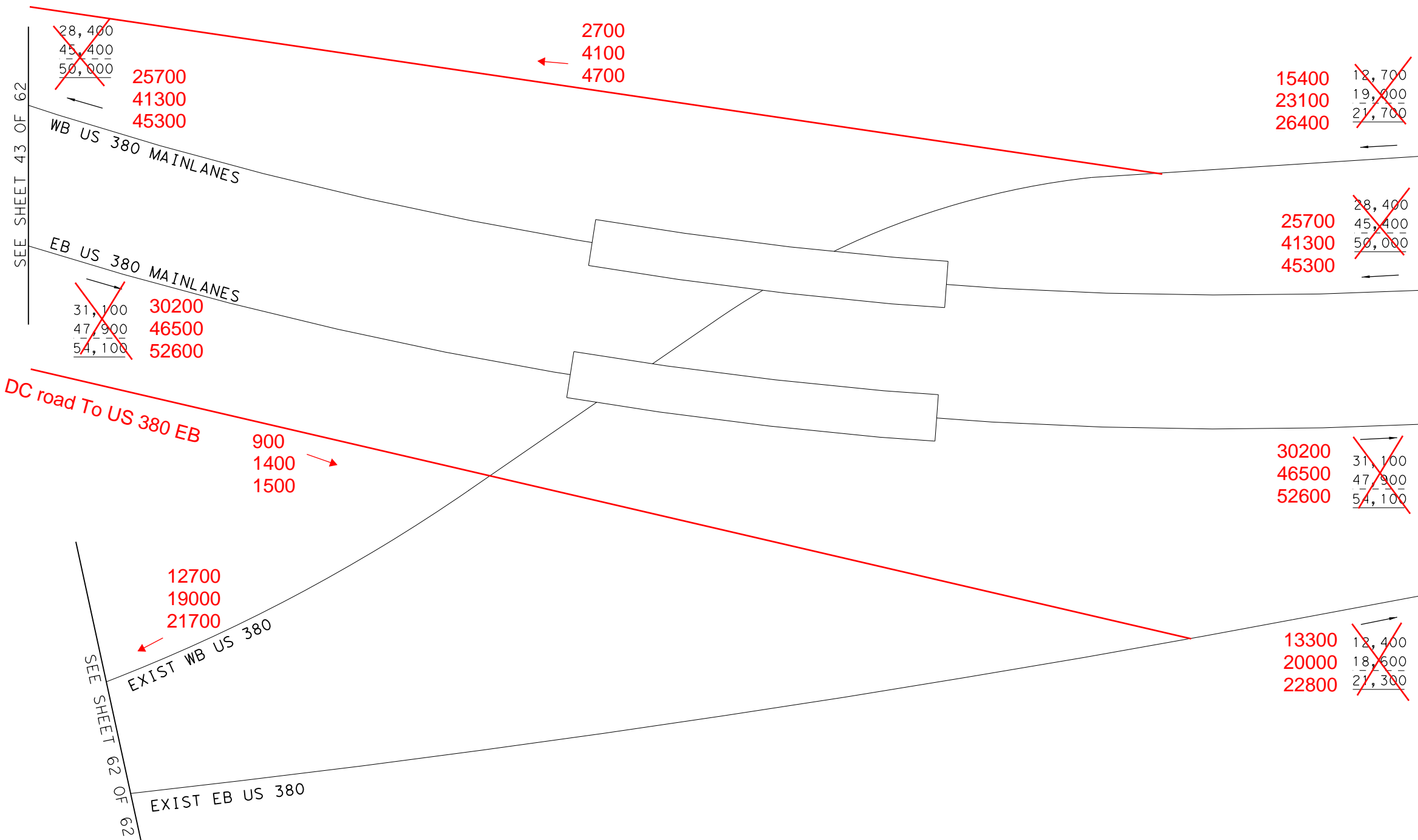
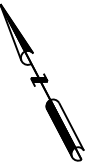
Kimley»Horn
F-928

0135-02-065,
 ETC. SHEET 43 OF 62

LEGEND

- XXXX- 2030 AVERAGE DAILY TRAFFIC VOLUMES
- XXXX- 2050 AVERAGE DAILY TRAFFIC VOLUMES
- XXXX- 2060 AVERAGE DAILY TRAFFIC VOLUMES

DATE: 7/13/2021
 FILE: US380_PURPLE_TRF_43.dgn



SEE SHEET 43 OF 62

SEE SHEET 45 OF 62

SEE SHEET 62 OF 62

SEE SHEET 45 OF 62

NOT TO SCALE

NOT INTENDED FOR CONSTRUCTION,
 BIDDING OR PERMIT PURPOSES
 DHRUVA LAHON, P.E.
 SERIAL NUMBER 102185

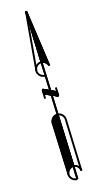
US 380 PURPLE ALT AND
 RAMPS
 AVERAGE DAILY TRAFFIC
 PURPLE ALT BUILD VOLUMES

Kimley»Horn
F-928

0135-02-065,
 ETC. SHEET 44 OF 62

LEGEND

- XXXX- 2030 AVERAGE DAILY TRAFFIC VOLUMES
- XXXX- 2050 AVERAGE DAILY TRAFFIC VOLUMES
- XXXX- 2060 AVERAGE DAILY TRAFFIC VOLUMES



SEE SHEET 44 OF 62

SEE SHEET 46 OF 62

12,700	15400
19,000	23100
21,700	26400

20100	41,100
30600	64,400
34200	71,700

WB US 380 FR

28,400	25700
45,400	41300
50,000	45300

← **4700**
7500
7800

← **21000**
33800
37500

WB US 380 MAINLANES

EB US 380 MAINLANES

31,100	30200
47,900	46500
54,100	52600

4100 →
6200
7200

26100
40300 →
45400

EB US 380 FR

12,400	13300
18,600	20000
21,300	22800

17400	43,500
26200	66,500
30000	75,400

NOT TO SCALE

NOT INTENDED FOR CONSTRUCTION,
BIDDING OR PERMIT PURPOSES
DHURVA LAHON, P.E.
SERIAL NUMBER 102185

US 380 PURPLE ALT AND
RAMPS
AVERAGE DAILY TRAFFIC
PURPLE ALT BUILD VOLUMES

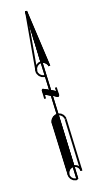
Kimley»Horn
F-928

0135-02-065,
ETC. SHEET 45 OF 62

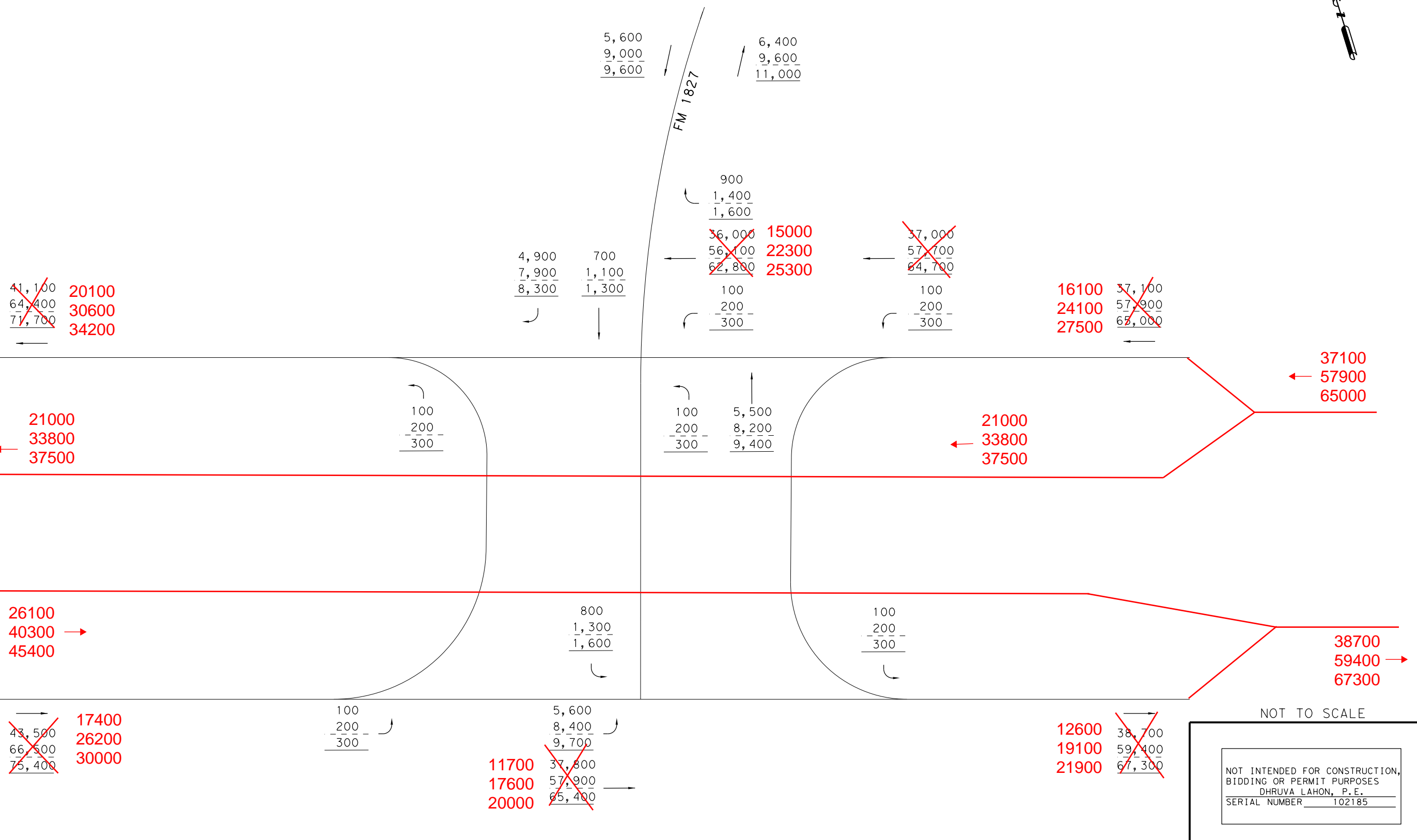
LEGEND

- XXXX- 2030 AVERAGE DAILY TRAFFIC VOLUMES
- XXXX- 2050 AVERAGE DAILY TRAFFIC VOLUMES
- XXXX- 2060 AVERAGE DAILY TRAFFIC VOLUMES

DATE: 7/13/2021
FILE: US380_PURPLE_TRF_45.dgn



SEE SHEET 45 OF 62



~~41,100~~ 20100
~~64,400~~ 30600
~~71,700~~ 34200

4,900 700
~~7,900~~ 1,100
~~8,300~~ 1,300

5,600 6,400
~~9,000~~ 9,600
~~9,600~~ 11,000

900
~~1,400~~
~~1,600~~

~~36,000~~ 15000
~~56,400~~ 22300
~~62,800~~ 25300

~~37,000~~
~~57,400~~
~~64,700~~

16100
 24100
 27500

~~37,100~~
~~57,900~~
~~65,000~~

21000
 33800
 37500

100
~~200~~
~~300~~

100 5,500
~~200~~ 8,200
~~300~~ 9,400

21000
 33800
 37500

37100
 57900
 65000

26100
 40300
 45400

800
~~1,300~~
~~1,600~~

100
~~200~~
~~300~~

38700
 59400
 67300

~~43,500~~ 17400
~~66,500~~ 26200
~~75,400~~ 30000

100
~~200~~
~~300~~

11700
 17600
 20000

5,600
~~8,400~~
~~9,700~~

~~37,800~~
~~57,900~~
~~65,400~~

12600
 19100
 21900

~~38,700~~
~~59,400~~
~~67,300~~

NOT TO SCALE

NOT INTENDED FOR CONSTRUCTION,
 BIDDING OR PERMIT PURPOSES
 DHRUVA LAHON, P.E.
 SERIAL NUMBER 102185

US 380 PURPLE ALT AND
 NEW HOPE ROAD/ FM 1827
 AVERAGE DAILY TRAFFIC
 PURPLE ALT BUILD VOLUMES

Kimley»Horn
F-928

0135-02-065,
 ETC. SHEET 46 OF 62

LEGEND

- XXXX- 2030 AVERAGE DAILY TRAFFIC VOLUMES
- XXXX- 2050 AVERAGE DAILY TRAFFIC VOLUMES
- XXXX- 2060 AVERAGE DAILY TRAFFIC VOLUMES

DATE: 7/13/2021
FILE: US380_PURPLE_TRF_46.dgn



SEE SHEET 11A OF 62

SEE SHEET 48 OF 62

WB US 380 EXISTING

EB US 380 EXISTING

13,200
20,300
22,900

13,200
20,300
22,900

11,300
17,300
19,600
4,400
6,800
7,700

15,700
24,100
27,300

10,600
16,300
18,300
2,600
4,000
4,600

1,900 4,700
3,000 7,300
3,300 8,200

15,300
23,600
26,500

7,000
10,800
12,300

6,600
10,300
11,500

RIDGE ROAD

NOT TO SCALE

NOT INTENDED FOR CONSTRUCTION,
BIDDING OR PERMIT PURPOSES
DHURVA LAHON, P.E.
SERIAL NUMBER 102185

EXISTING US 380 AND
RIDGE RD
AVERAGE DAILY TRAFFIC

Kimley»Horn
F-928

0135-02-065,
ETC.

SHEET 47 OF 62

LEGEND

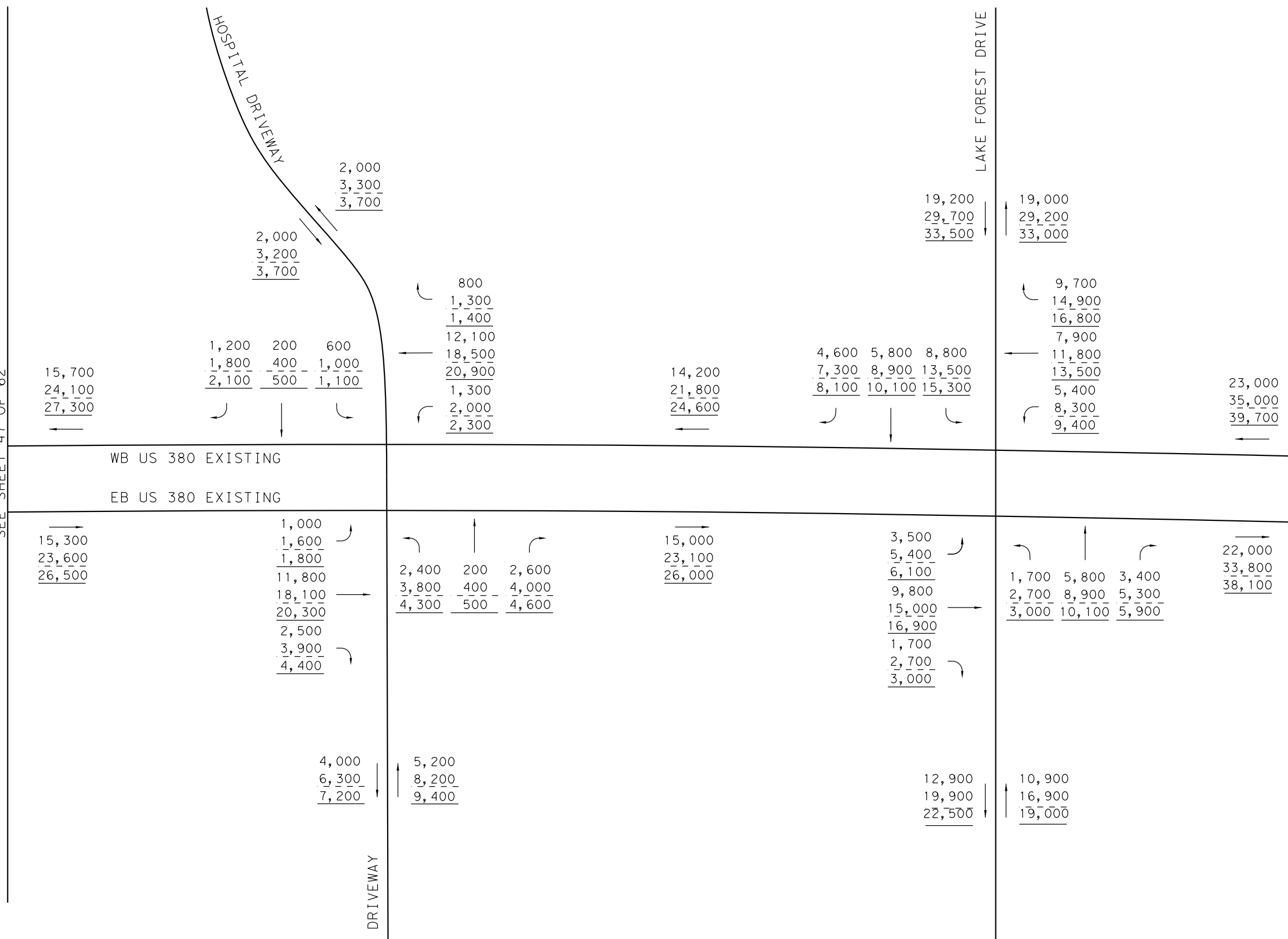
- XXXX- 2030 AVERAGE DAILY TRAFFIC VOLUMES
- XXXX- 2050 AVERAGE DAILY TRAFFIC VOLUMES
- XXXX- 2060 AVERAGE DAILY TRAFFIC VOLUMES

DATE: 7/13/2021
FILE: US380_PURPLE_TRF_47.dgn



SEE SHEET 47 OF 62

SEE SHEET 49 OF 62



WB US 380 EXISTING
 EB US 380 EXISTING

NOT TO SCALE

NOT INTENDED FOR CONSTRUCTION,
 BIDDING OR PERMIT PURPOSES
 DHRUVA LAHON, P.E.
 SERIAL NUMBER 102185

EXISTING US 380 AND
 LAKE FOREST DR
 AVERAGE DAILY TRAFFIC

Kimley»Horn
F-928

0135-02-065, ETC. SHEET 48 OF 62

LEGEND

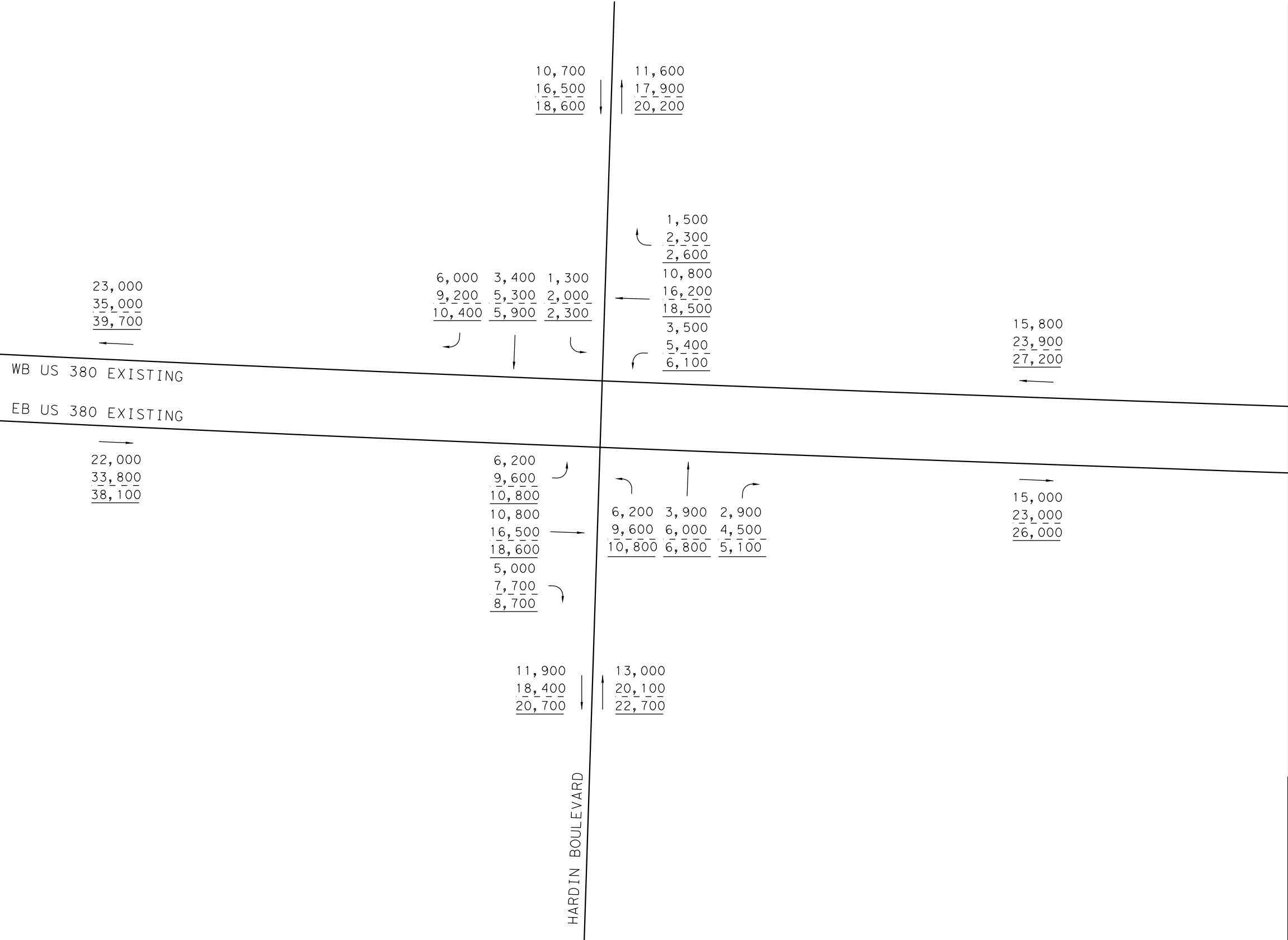
- XXXX- 2030 AVERAGE DAILY TRAFFIC VOLUMES
- XXXX- 2050 AVERAGE DAILY TRAFFIC VOLUMES
- XXXX- 2060 AVERAGE DAILY TRAFFIC VOLUMES

DATE: 7/13/2021
 FILE: US380_PURPLE_TRF_48.dgn



SEE SHEET 48 OF 62

SEE SHEET 50 OF 62



LEGEND

- XXXX- 2030 AVERAGE DAILY TRAFFIC VOLUMES
- XXXX- 2050 AVERAGE DAILY TRAFFIC VOLUMES
- XXXX- 2060 AVERAGE DAILY TRAFFIC VOLUMES

NOT TO SCALE

NOT INTENDED FOR CONSTRUCTION,
 BIDDING OR PERMIT PURPOSES
 DHRUVA LAHON, P.E.
 SERIAL NUMBER 102185

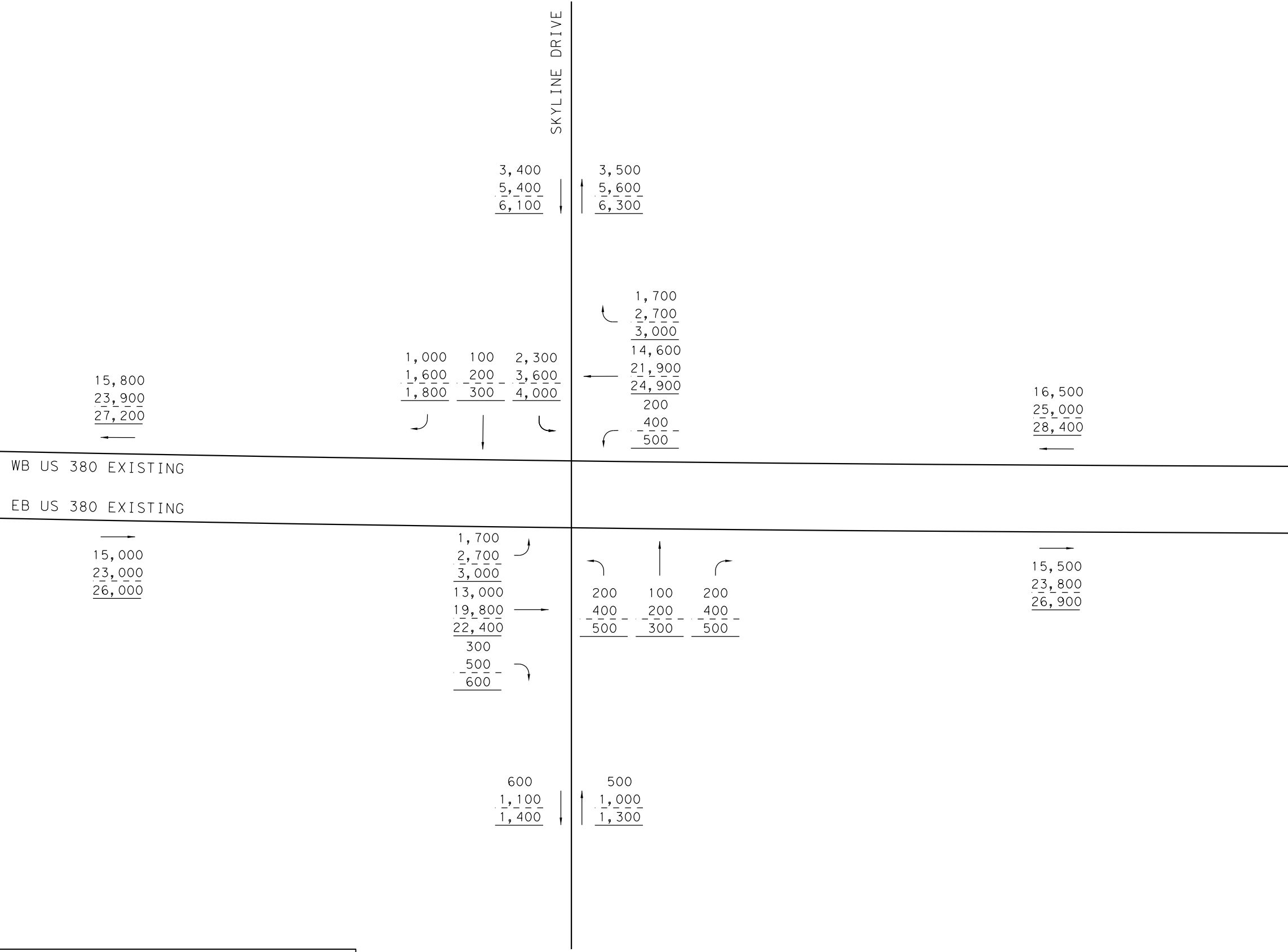
EXISTING US 380 AND HARDIN BLVD AVERAGE DAILY TRAFFIC





SEE SHEET 49 OF 62

SEE SHEET 51 OF 62



NOT TO SCALE

NOT INTENDED FOR CONSTRUCTION,
 BIDDING OR PERMIT PURPOSES
 DHRUVA LAHON, P.E.
 SERIAL NUMBER 102185

EXISTING US 380 AND
 SKYLINE DR
 AVERAGE DAILY TRAFFIC

Kimley»Horn
F-928

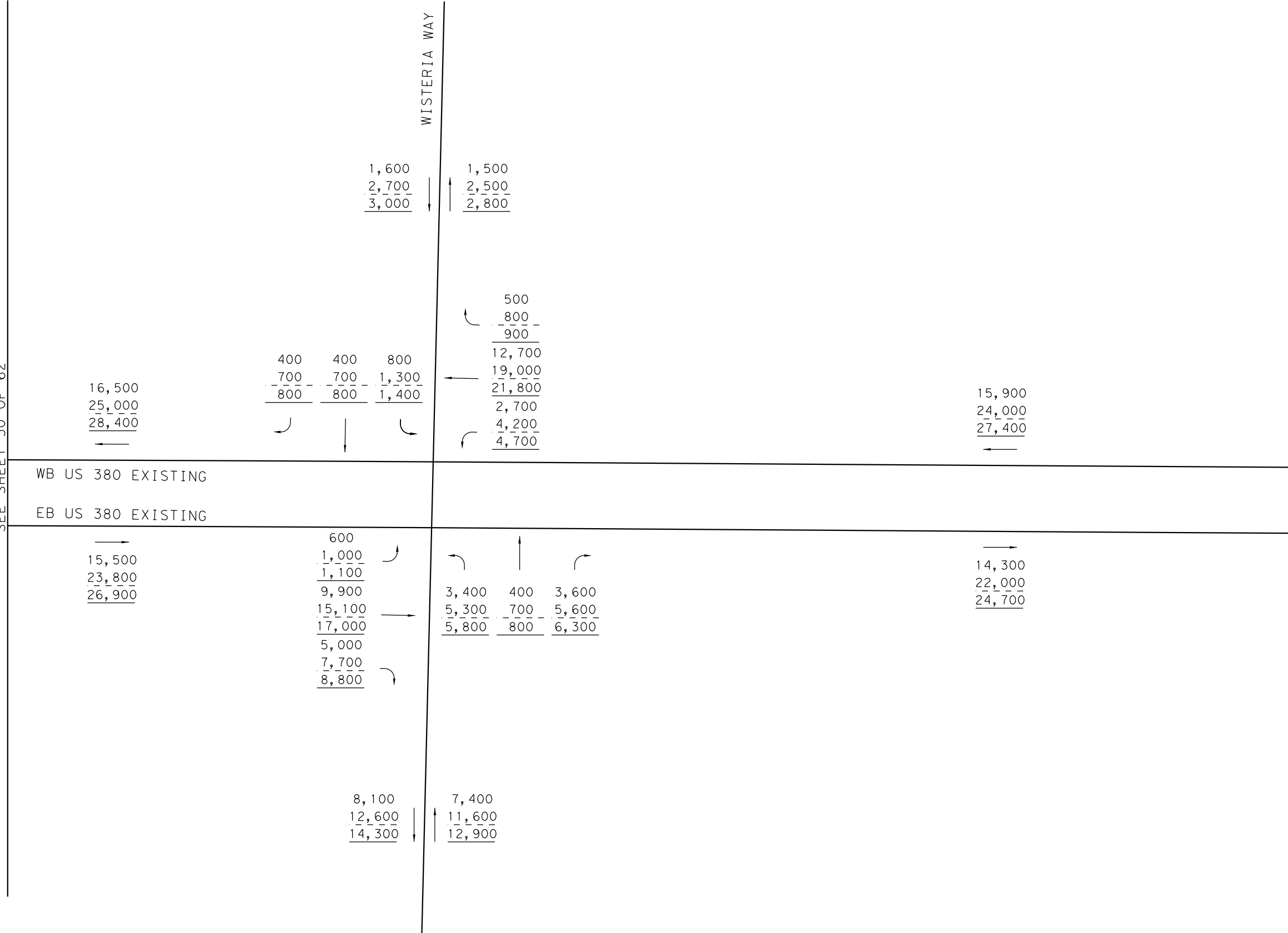
0135-02-065,
 ETC. SHEET 50 OF 62

DATE: 7/13/2021
 FILE: US380_Purple_TRF_50.dgn



SEE SHEET 50 OF 62

SEE SHEET 52 OF 62



WB US 380 EXISTING
EB US 380 EXISTING

NOT TO SCALE

NOT INTENDED FOR CONSTRUCTION,
BIDDING OR PERMIT PURPOSES
DHURVA LAHON, P.E.
SERIAL NUMBER 102185

EXISTING US 380 AND
WISTERIA WAY
AVERAGE DAILY TRAFFIC

Kimley»Horn
F-928

0135-02-065,
ETC. SHEET 51 OF 62

LEGEND

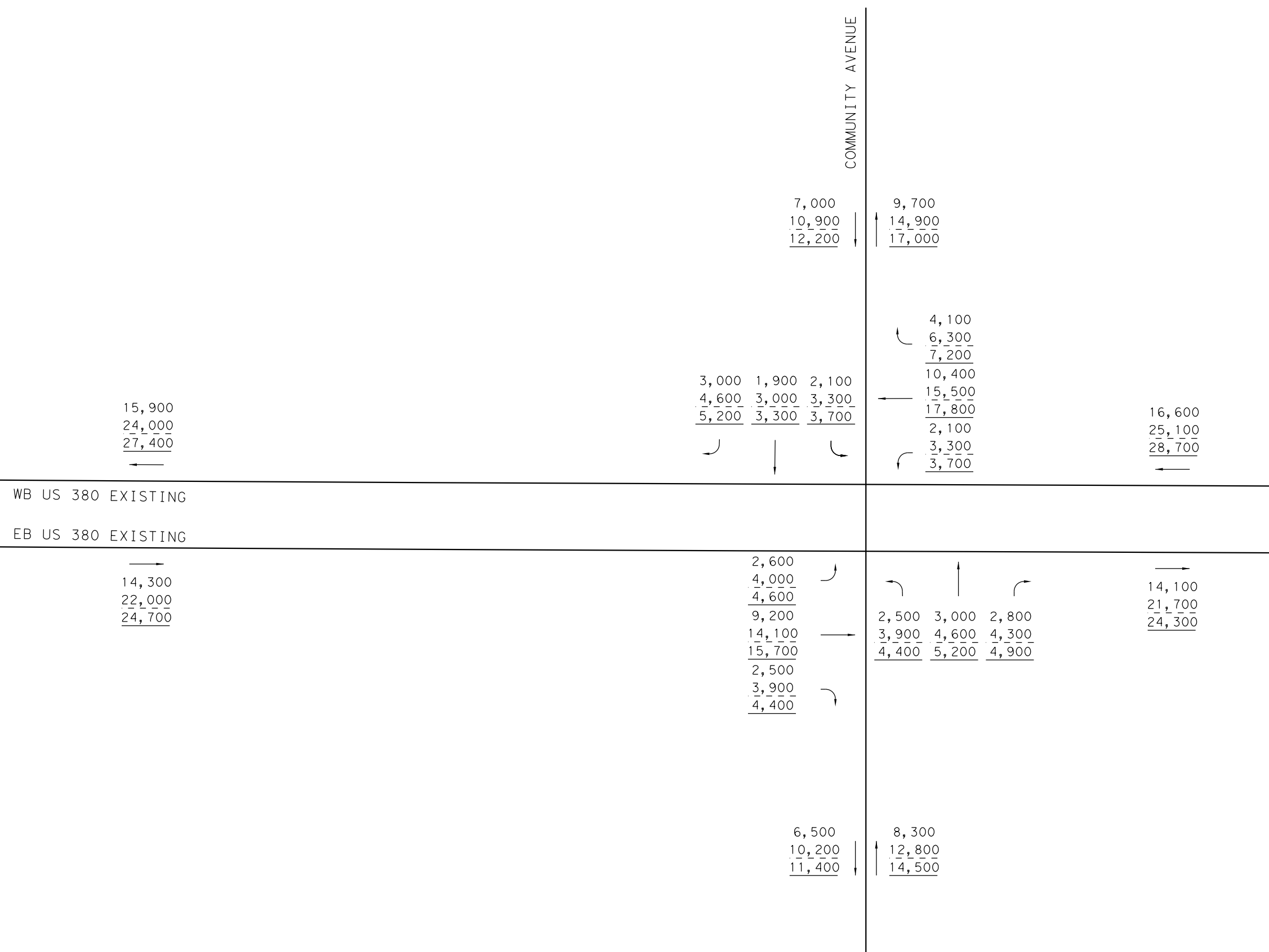
- XXXX- 2030 AVERAGE DAILY TRAFFIC VOLUMES
- XXXX- 2050 AVERAGE DAILY TRAFFIC VOLUMES
- XXXX- 2060 AVERAGE DAILY TRAFFIC VOLUMES

DATE: 7/13/2021
FILE: US380_PURPLE_TRF_51.dgn



SEE SHEET 51 OF 62

SEE SHEET 53 OF 62



NOT TO SCALE

NOT INTENDED FOR CONSTRUCTION,
 BIDDING OR PERMIT PURPOSES
 DHRUVA LAHON, P.E.
 SERIAL NUMBER 102185

EXISTING US 380 AND
 COMMUNITY AVE
 AVERAGE DAILY TRAFFIC

Kimley»Horn
F-928

0135-02-065,
 ETC. SHEET 52 OF 62

LEGEND

- XXXX- 2030 AVERAGE DAILY TRAFFIC VOLUMES
- XXXX- 2050 AVERAGE DAILY TRAFFIC VOLUMES
- XXXX- 2060 AVERAGE DAILY TRAFFIC VOLUMES

DATE: 7/13/2021
 FILE: US380_Purple_TRF_52.dgn



SEE SHEET 52 OF 62

SEE SHEET 54 OF 62

WB US 380 EXISTING
EB US 380 EXISTING

TOWNE CROSSING

16,600
25,100
28,700

2,600 400 1,500
4,000 700 2,300
4,600 800 2,600

4,500
7,000
8,000

3,000
4,800
5,400

200
400
500
11,700
17,500
20,100
1,400
2,200
2,500

13,300
20,100
23,100

14,100
21,700
24,300

2,000
3,100
3,500
10,900
16,700
18,700
1,200
1,900
2,100

2,300 800 800
3,600 1,300 1,300
4,000 1,400 1,400

13,200
20,300
22,700

3,000
4,800
5,400

3,900
6,200
6,800

NOT TO SCALE

NOT INTENDED FOR CONSTRUCTION,
BIDDING OR PERMIT PURPOSES
DHURVA LAHON, P.E.
SERIAL NUMBER 102185

EXISTING US 380 AND
TOWNE CROSSING
AVERAGE DAILY TRAFFIC

Kimley»Horn
F-928

0135-02-065,
ETC. SHEET 53 OF 62

LEGEND

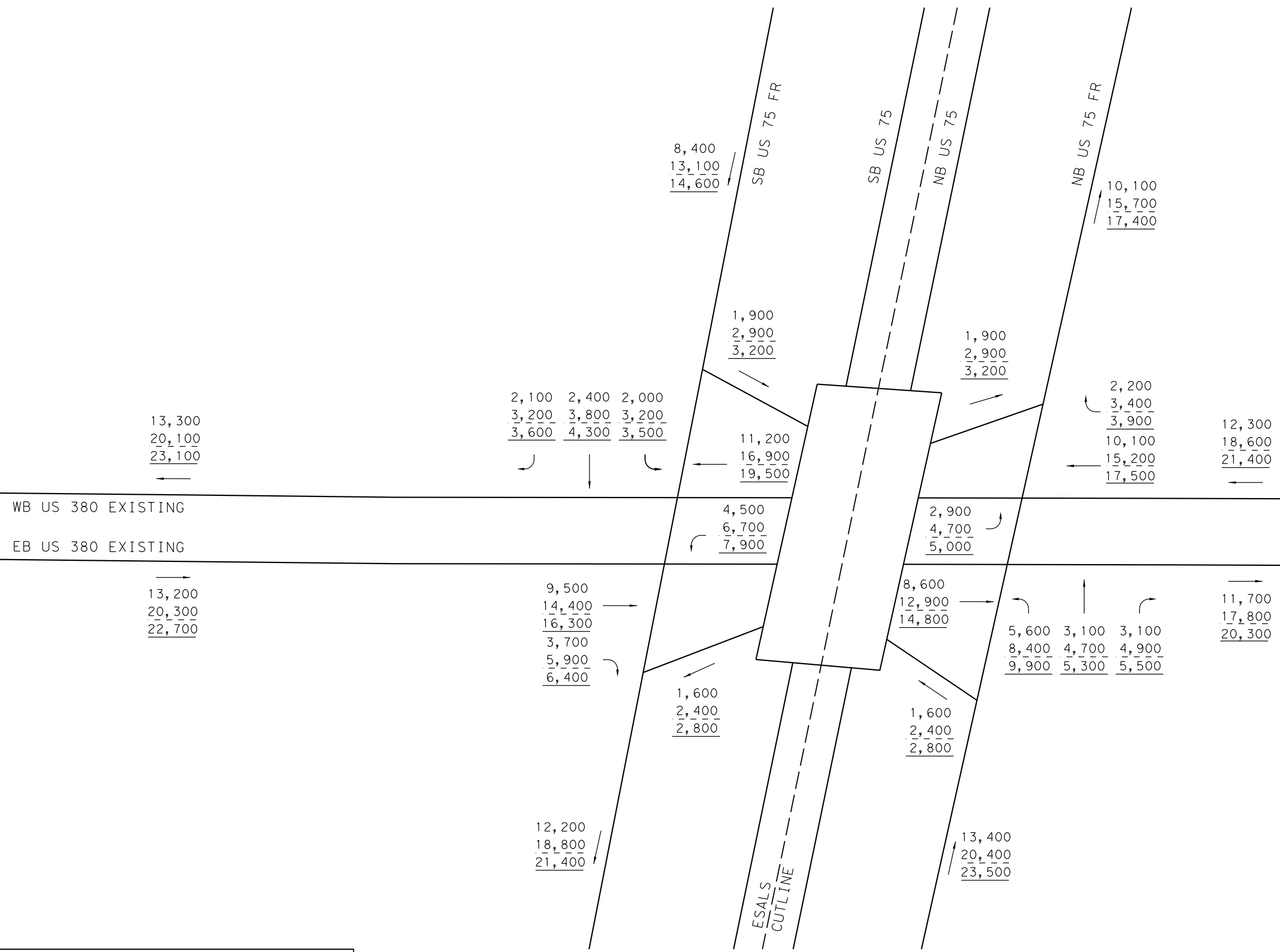
- XXXX- 2030 AVERAGE DAILY TRAFFIC VOLUMES
- XXXX- 2050 AVERAGE DAILY TRAFFIC VOLUMES
- XXXX- 2060 AVERAGE DAILY TRAFFIC VOLUMES

DATE: 7/13/2021
FILE: US380_Purple_TRF_53.dgn



SEE SHEET 53 OF 62

SEE SHEET 55 OF 62



NOT TO SCALE

NOT INTENDED FOR CONSTRUCTION,
 BIDDING OR PERMIT PURPOSES
 DHRUVA LAHON, P.E.
 SERIAL NUMBER 102185

EXISTING US 380 AND
 US 75
 AVERAGE DAILY TRAFFIC

Kimley»Horn
F-928

0135-02-065,
 ETC. SHEET 54 OF 62

LEGEND

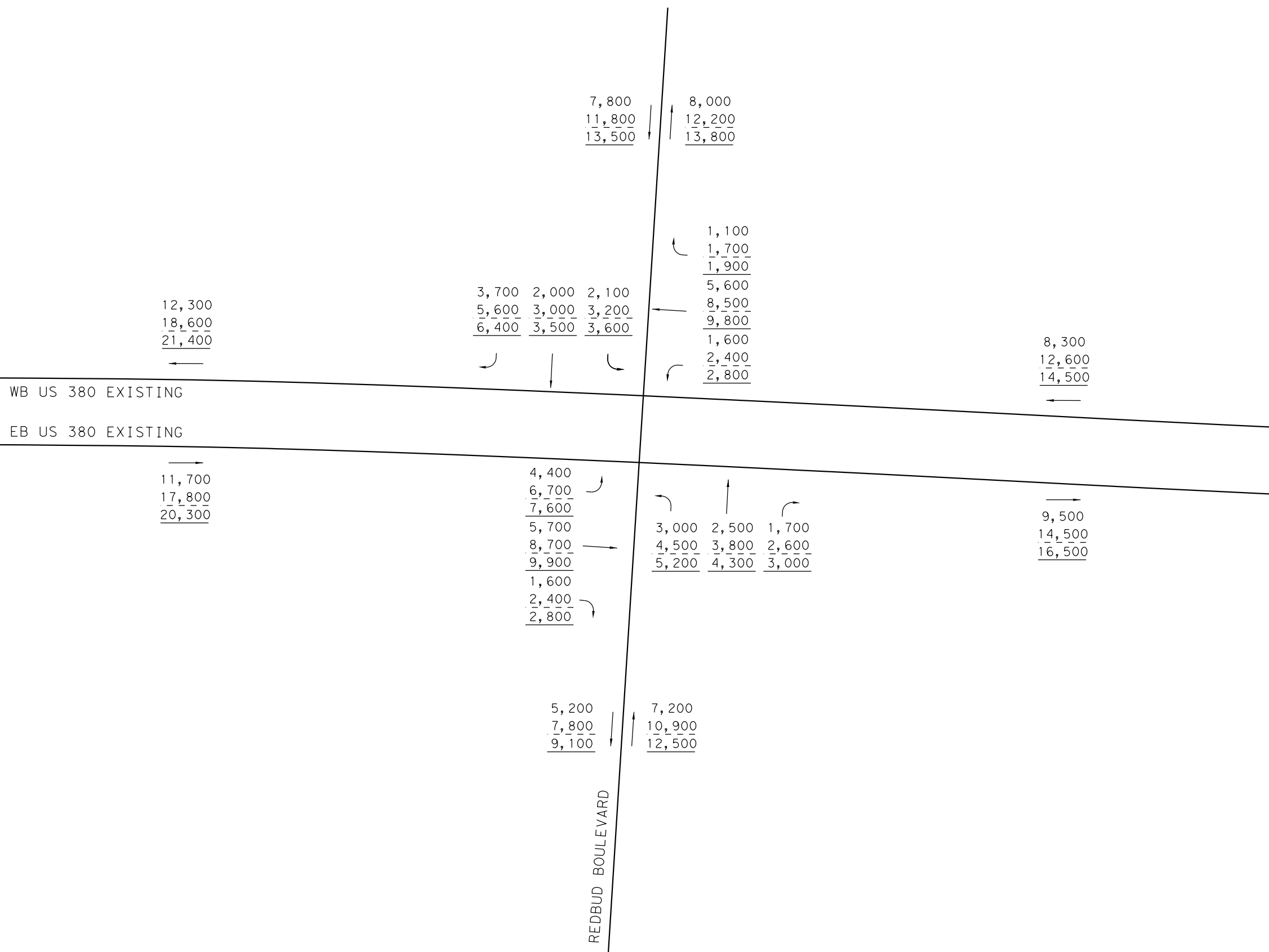
- XXXX- 2030 AVERAGE DAILY TRAFFIC VOLUMES
- XXXX- 2050 AVERAGE DAILY TRAFFIC VOLUMES
- XXXX- 2060 AVERAGE DAILY TRAFFIC VOLUMES

DATE: 7/13/2021
 FILE: US380_PURPLE_TRF_54.dgn



SEE SHEET 54 OF 62

SEE SHEET 56 OF 62



WB US 380 EXISTING
EB US 380 EXISTING

REDBUD BOULEVARD

NOT TO SCALE

NOT INTENDED FOR CONSTRUCTION,
BIDDING OR PERMIT PURPOSES
DHURVA LAHON, P.E.
SERIAL NUMBER 102185

EXISTING US 380 AND
REDBUD RD
AVERAGE DAILY TRAFFIC

Kimley»Horn
F-928

0135-02-065,
ETC. SHEET 55 OF 62

LEGEND

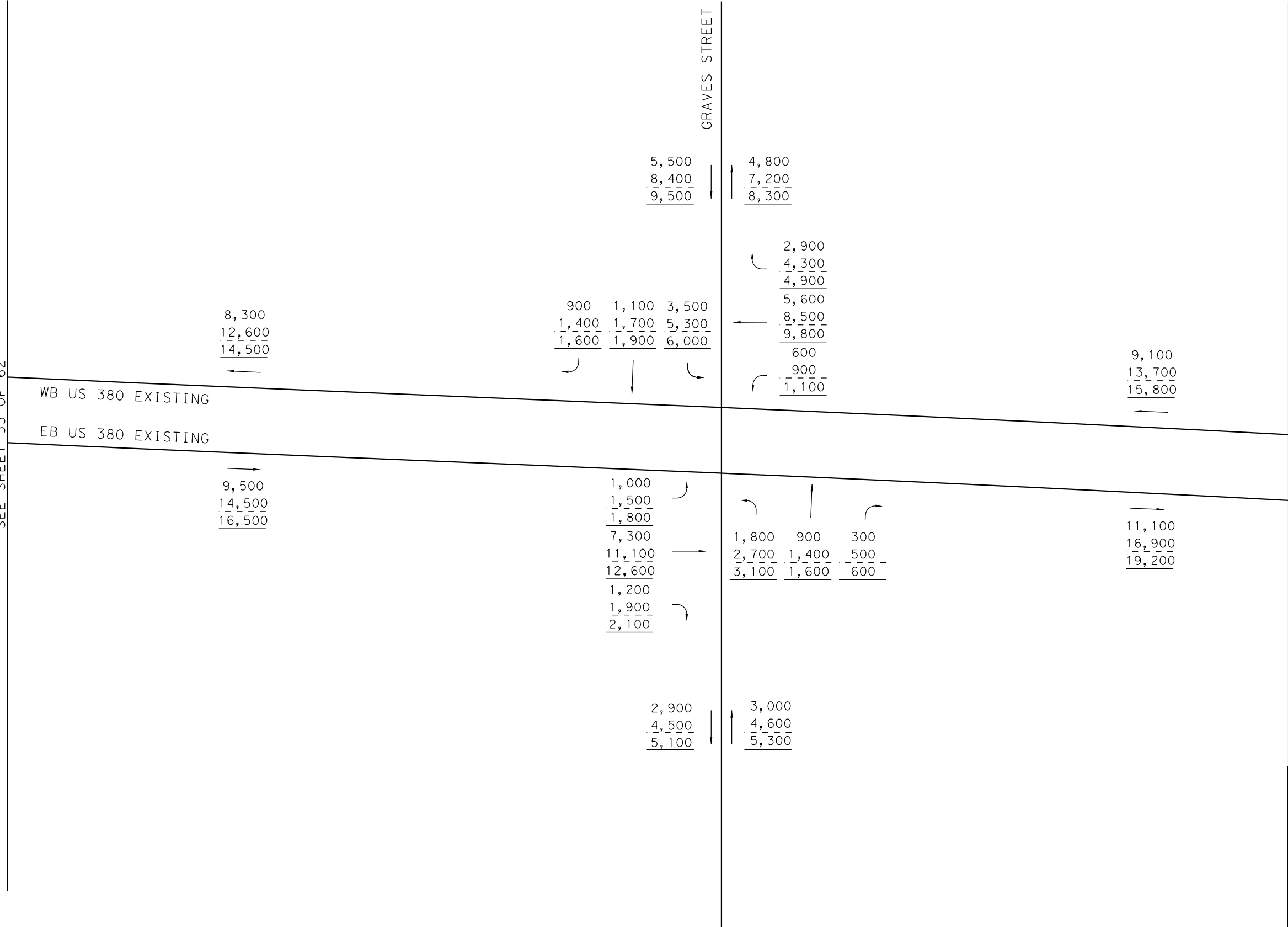
- XXXX- 2030 AVERAGE DAILY TRAFFIC VOLUMES
- XXXX- 2050 AVERAGE DAILY TRAFFIC VOLUMES
- XXXX- 2060 AVERAGE DAILY TRAFFIC VOLUMES

DATE: 7/13/2021
FILE: US380_Purple_TRF_55.dgn



SEE SHEET 55 OF 62

SEE SHEET 57 OF 62



WB US 380 EXISTING
 EB US 380 EXISTING

GRAVES STREET

NOT TO SCALE

NOT INTENDED FOR CONSTRUCTION,
 BIDDING OR PERMIT PURPOSES
 DHRUVA LAHON, P.E.
 SERIAL NUMBER 102185

EXISTING US 380 AND
 GRAVES ST
 AVERAGE DAILY TRAFFIC

Kimley»Horn
F-928

0135-02-065,
 ETC. SHEET 56 OF 62

LEGEND

- XXXX- 2030 AVERAGE DAILY TRAFFIC VOLUMES
- XXXX- 2050 AVERAGE DAILY TRAFFIC VOLUMES
- XXXX- 2060 AVERAGE DAILY TRAFFIC VOLUMES

DATE: 7/13/2021
 FILE: US380_PURPLE_TRF_56.dgn



SEE SHEET 56 OF 62

SEE SHEET 58 OF 62

WB US 380 EXISTING

EB US 380 EXISTING

WADDILL STREET

9,100
13,700
15,800

200 200 600
300 300 900
400 400 1,100

1,000 600
1,500 900
1,900 1,200

200
300
400
8,200
12,300
14,100
900
1,400
1,600

9,300
14,000
16,100

11,100
16,900
19,200

200
300
400
9,800
14,900
16,900
1,100
1,700
1,900

700 200 1,300
1,100 300 2,000
1,300 400 2,300

11,700
17,800
20,300

2,200 2,200
3,400 3,400
3,900 4,000

NOT TO SCALE

NOT INTENDED FOR CONSTRUCTION,
BIDDING OR PERMIT PURPOSES
DHURVA LAHON, P.E.
SERIAL NUMBER 102185

EXISTING US 380 AND
WADDILL ST
AVERAGE DAILY TRAFFIC

Kimley»Horn
F-928

0135-02-065,
ETC. SHEET 57 OF 62

LEGEND

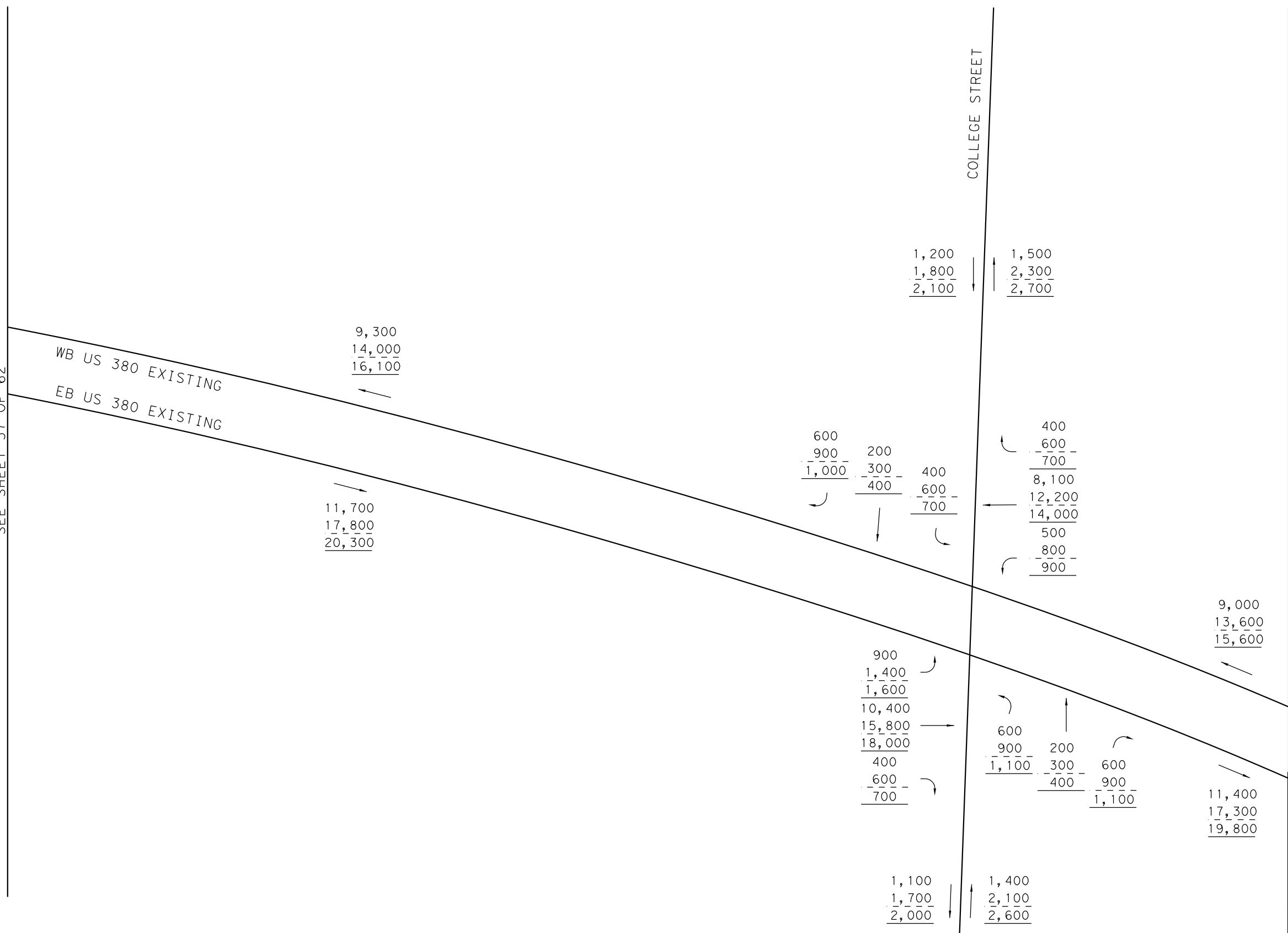
- XXXX- 2030 AVERAGE DAILY TRAFFIC VOLUMES
- XXXX- 2050 AVERAGE DAILY TRAFFIC VOLUMES
- XXXX- 2060 AVERAGE DAILY TRAFFIC VOLUMES

DATE: 7/13/2021
FILE: US380_Purple_TRF_57.dgn



SEE SHEET 57 OF 62

SEE SHEET 59 OF 62



NOT TO SCALE

NOT INTENDED FOR CONSTRUCTION,
BIDDING OR PERMIT PURPOSES
DHURVA LAHON, P.E.
SERIAL NUMBER 102185

EXISTING US 380 AND
COLLEGE ST
AVERAGE DAILY TRAFFIC

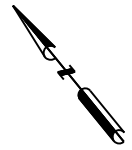
Kimley»Horn
F-928

0135-02-065,
ETC. SHEET 58 OF 62

LEGEND

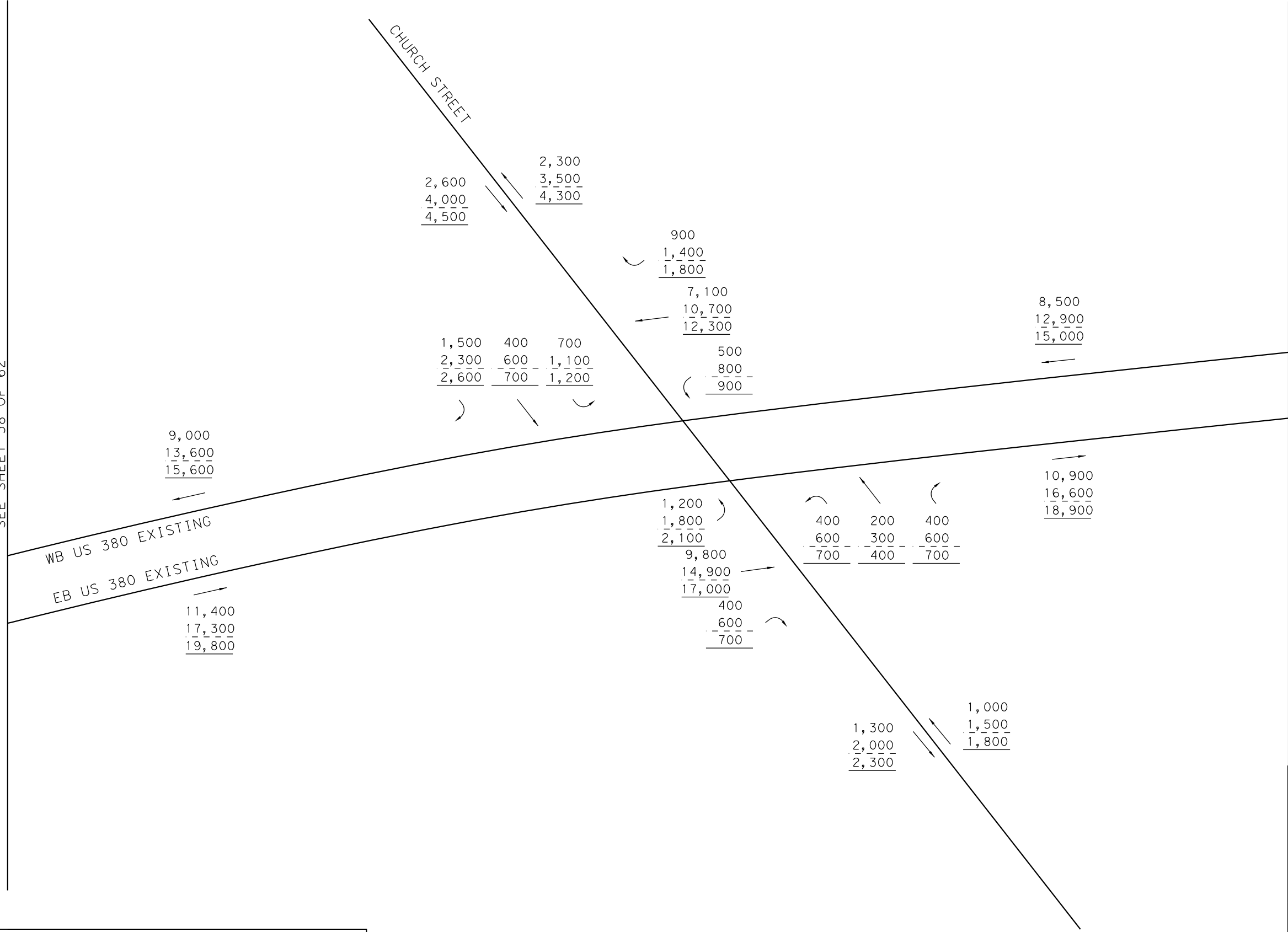
- XXXX- 2030 AVERAGE DAILY TRAFFIC VOLUMES
- XXXX- 2050 AVERAGE DAILY TRAFFIC VOLUMES
- XXXX- 2060 AVERAGE DAILY TRAFFIC VOLUMES

DATE: 7/13/2021
FILE: US380_Purple_TRF_58.dgn



SEE SHEET 58 OF 62

SEE SHEET 60 OF 62



NOT TO SCALE

NOT INTENDED FOR CONSTRUCTION,
 BIDDING OR PERMIT PURPOSES
 DHRUVA LAHON, P.E.
 SERIAL NUMBER 102185

EXISTING US 380 AND
 CHURCH ST
 AVERAGE DAILY TRAFFIC

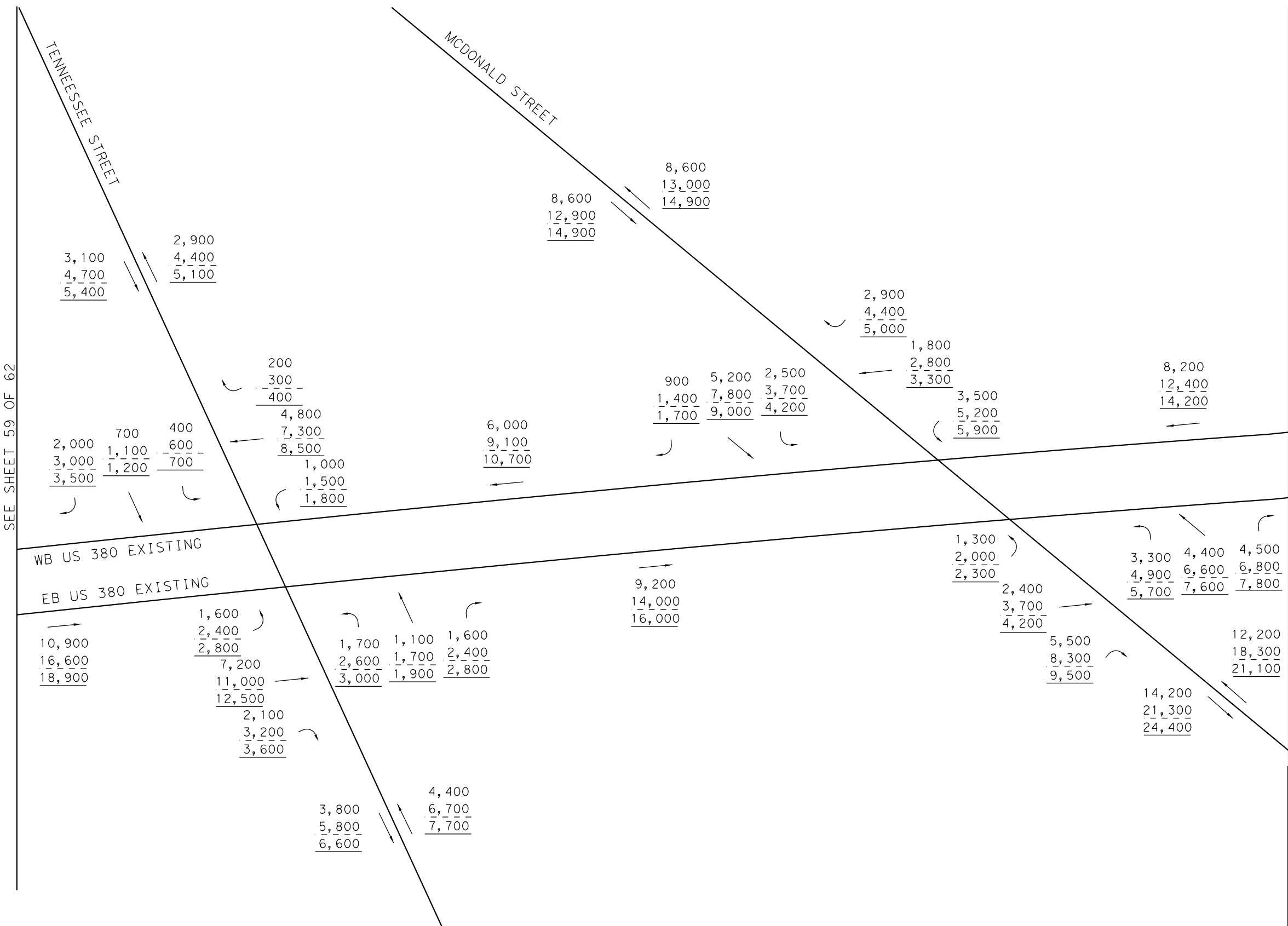
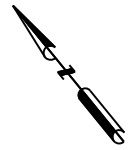
Kimley»Horn
F-928

0135-02-065,
 ETC. SHEET 59 OF 62

LEGEND

- XXXX- 2030 AVERAGE DAILY TRAFFIC VOLUMES
- XXXX- 2050 AVERAGE DAILY TRAFFIC VOLUMES
- XXXX- 2060 AVERAGE DAILY TRAFFIC VOLUMES

DATE: 7/13/2021
 FILE: US380_Purple_TRF_59.dgn



SEE SHEET 59 OF 62

SEE SHEET 61 OF 62

NOT TO SCALE

NOT INTENDED FOR CONSTRUCTION,
 BIDDING OR PERMIT PURPOSES
 DHRUVA LAHON, P.E.
 SERIAL NUMBER 102185

EXISTING US 380 AND
 MCDONALD ST/ SH 5
 AVERAGE DAILY TRAFFIC

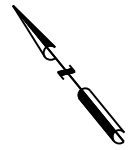
Kimley»Horn
F-928

0135-02-065,
 ETC. SHEET 60 OF 62

LEGEND

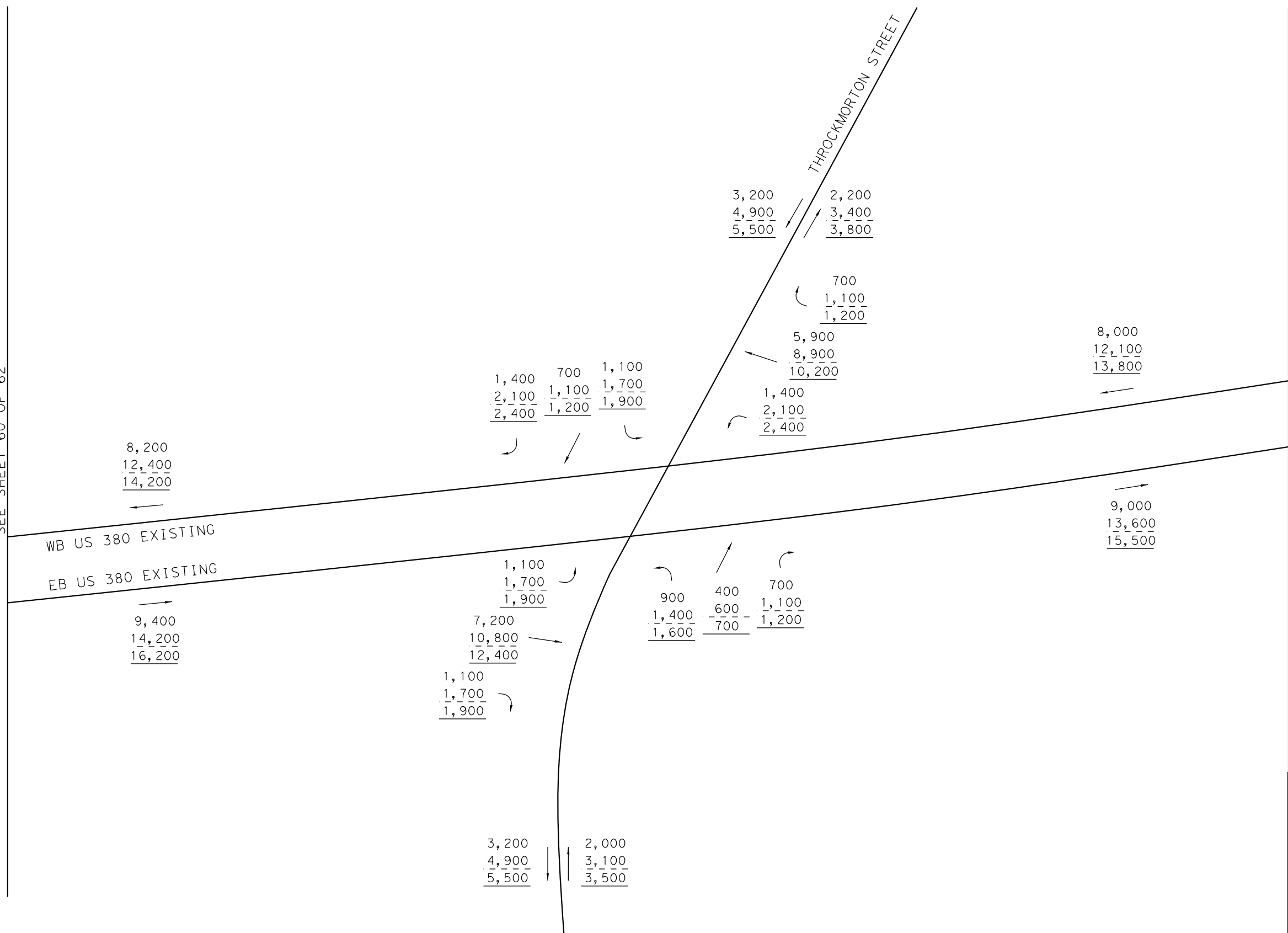
- XXXX- 2030 AVERAGE DAILY TRAFFIC VOLUMES
- XXXX- 2050 AVERAGE DAILY TRAFFIC VOLUMES
- XXXX- 2060 AVERAGE DAILY TRAFFIC VOLUMES

DATE: 7/13/2021
 FILE: US380_Purple_TRF_60.dgn



SEE SHEET 60 OF 62

SEE SHEET 62 OF 62



LEGEND

- XXXX- 2030 AVERAGE DAILY TRAFFIC VOLUMES
- XXX- 2050 AVERAGE DAILY TRAFFIC VOLUMES
- XX- 2060 AVERAGE DAILY TRAFFIC VOLUMES

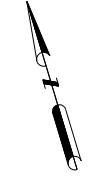
NOT TO SCALE

NOT INTENDED FOR CONSTRUCTION,
 BIDDING OR PERMIT PURPOSES
 DHRUVA LAHON, P.E.
 SERIAL NUMBER 102185

EXISTING US 380 AND THROCKMORTON ST AVERAGE DAILY TRAFFIC



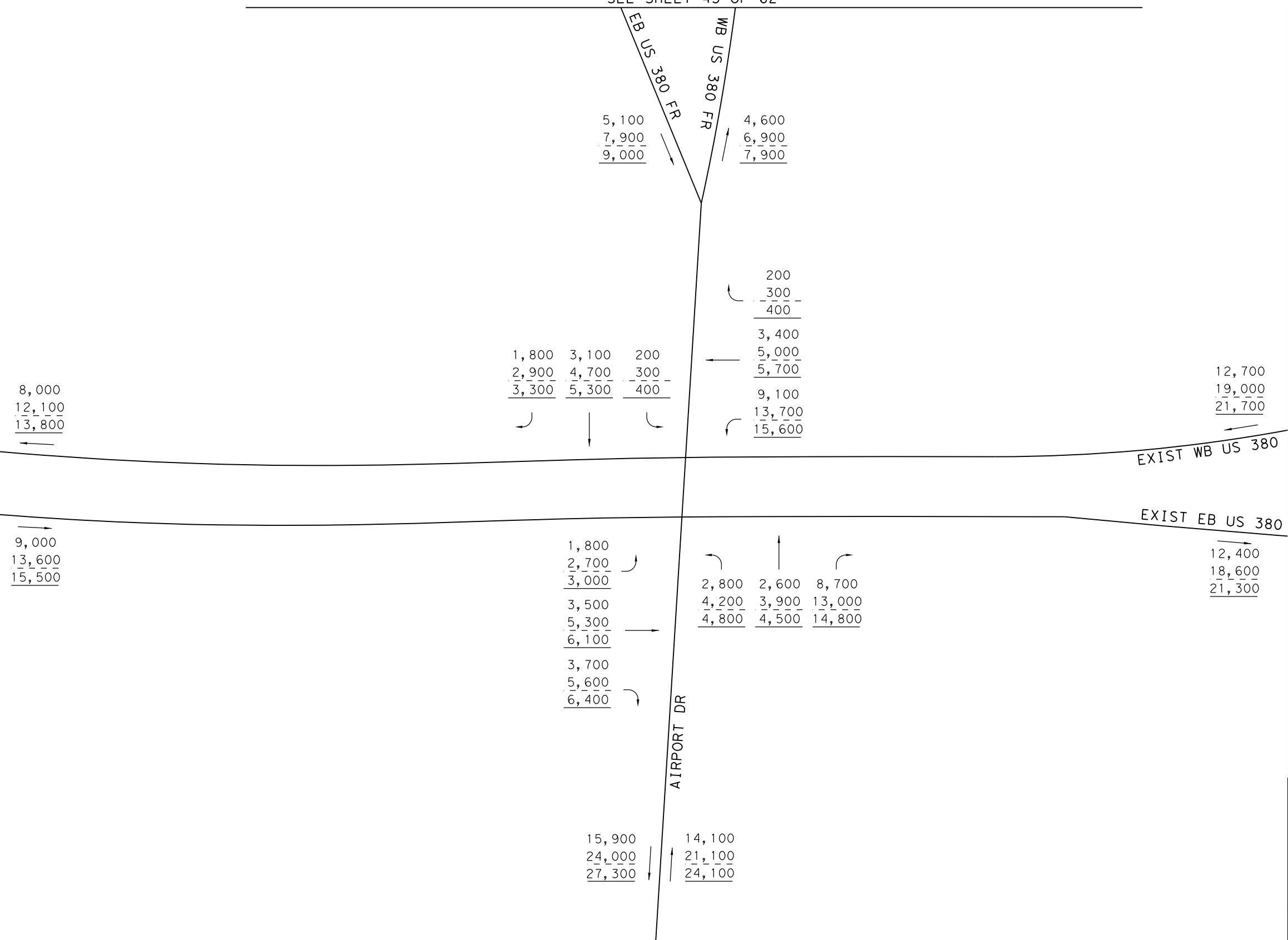
DATE: 7/13/2021 FILE: US380_Purple_TRF_61.dgn



SEE SHEET 43 OF 62

SEE SHEET 61 OF 62

SEE SHEET 44 OF 62



LEGEND

- XXXX- 2030 AVERAGE DAILY TRAFFIC VOLUMES
- XXXX- 2050 AVERAGE DAILY TRAFFIC VOLUMES
- XXXX- 2060 AVERAGE DAILY TRAFFIC VOLUMES

NOT TO SCALE

NOT INTENDED FOR CONSTRUCTION,
BIDDING OR PERMIT PURPOSES
DHURVA LAHON, P.E.
SERIAL NUMBER 102185

EXISTING US 380 AND
AIRPORT DR
AVERAGE DAILY TRAFFIC



Attachment C: Existing Model Validation Study

A validation study was performed in order to verify that the existing model accurately predicts existing traffic noise based on current conditions and to ensure that traffic noise is the main source of noise. Model validation compares field-collected sound level measurements to traffic noise levels calculated in an existing condition model that used field-collected traffic parameters.

Eleven validation sites were selected along the project ROW (see Attachment A). Field measurements were collected on December 14 and 16, 2021 between 8 AM and 5 PM. The weather varied from foggy and overcast to sunny, with light winds less than 12 mph, and no adverse weather conditions obscuring measured levels. During the measurements, traffic was free-flowing and traveling at a relatively constant speed.

A sound level meter was used to measure sound levels in dB(A) Leq. The sound level meter was positioned on a tripod with the microphone facing the roadway and set at a nominal height of five feet. The measurement duration was 30 minutes. The meter was calibrated before measurements were taken and at the end of the day.

Concurrently with each sound level measurement, traffic was counted by personnel in the field to obtain traffic counts by vehicle classification (car, medium truck, and heavy truck). Because the noise modeling software uses a vehicle per hour input, vehicle counts for the 30-minute measurement interval were multiplied by appropriate values to convert counts to the hourly condition. Field data sheets are included at the end of Attachment C.

The FHWA traffic noise modeling software (TNM 2.5) was used to calculate existing traffic noise levels at each validation location, based on the field-observed conditions. The validation model run(s) used the existing roadway parameters, observed hourly traffic counts, and observed speeds.

The traffic noise model validation results are shown in **Table C-1**.

Table C-1. Traffic Noise Levels dB(A) Leq

Validation Site	Field-Measured Level dB(A) Leq	Modeled Level dB(A) Leq	Difference (+/-)	Validated?
ML-1	61.9	64.5	2.6	Yes
ML-2	62.1	64.8	2.7	Yes
ML-3	62.4	59.4	-3.0	Yes
ML-4	69.2	72.2	3.0	Yes
ML-5	59.3	59.9	0.6	Yes
ML-6	70.2	69.2	-1.0	Yes
ML-9	55.2	55.2	0.0	Yes
ML-13	60.5	58.3	-2.2	Yes
ML-14	69.5	69.7	0.2	Yes
ML-15	57.3	54.8	-2.5	Yes
ML-17	66.3	63.4	-2.9	Yes

Differences between the measured and model-calculated sound levels were within the +/- 3 dB(A) tolerance allowed by FHWA. Therefore, the existing noise model is considered validated for this project.



SHORT-TERM TRAFFIC NOISE MONITORING LOG SHEET

Reading: ML-1

Project Description: 10226441 - BMCD US380 Spur399 SCH ENV

Noise Source: US 380 – University Drive Traffic Date: Dec. 14, 2021 Personnel: RMB

Equipment	Type	Serial #
Sound Level Meter	Larson Davis	824A2636
Microphone/Preamp	Larson Davis 2541; PRM902	7490
Calibrator	Larson Davis CAL200	2618

SLM SETTINGS (circle one)

FAST

SLOW

WEIGHTING (circle one)

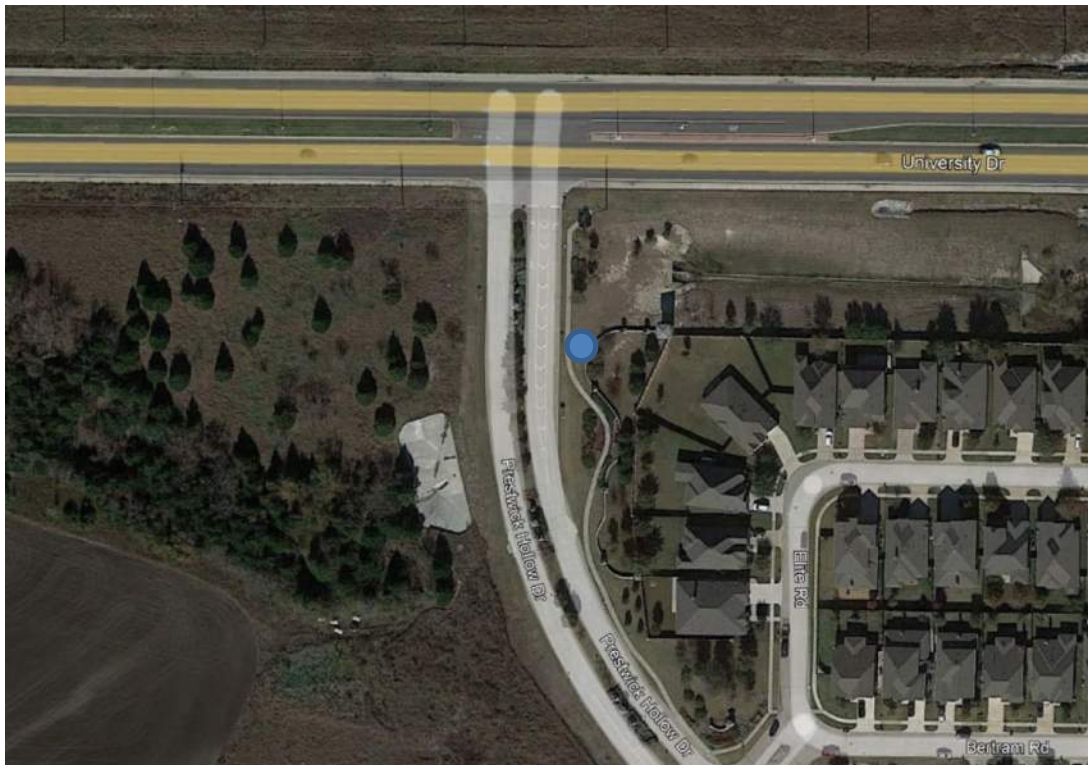
A

Lin.

Location Description: Location ML-1 – US 380 University Drive

SITE SKETCH: Including noise source, receptors, reference distances, North arrow, wind direction arrow, terrain and shielding, roadway profile, and direct lines of sight:

SLM placed on south side of roadway, ~170ft from edge of nearest travel lane of US 380 and 25ft from edge of right-hand turning lane of Prestwick Hollow Drive. Good line-of-sight.



Posted speed 55 mph. Free-flowing traffic at speed. Traffic noise dominant ; all measurements valid. Some traffic noise due to vehicle pass-bys on Prestwick Hollow Dr (30 mph posted).



Start Time:

8:00 AM PM

Stop Time:

8:30 AM PM

Duration:

30 minutes

Wind Speed/Direction: 9 mph S

Percentiles: _____

Temperature: 57-64 F

Humidity: 96% RH (Some fog)

Calibration results before: _____114.2 dBA and after _____114.1 dBA

Traffic Count Roadway: US 380 – University Drive EB (Top Row) and WB (Bottom Row)

Autos	Medium Trucks	Heavy Trucks	Buses	Motorcycles
392 per 15 minutes	3 per 15 minutes	20 per 15 minutes	---	---
444 per 15 minutes	2 per 15 minutes	17 per 15 minutes	1 per 15 minutes	----

***Note roadway direction in table**



SHORT-TERM TRAFFIC NOISE MONITORING LOG SHEET

PROJECT: 10226441 - BMCD US380 Spur399 SCH ENV
 JOB NO.: 10226441

SITE/READING NO.: File 3

PERSONNEL: RMB

LOCATION/ADDRESS: Location ML-1

DATE: 12/14/2021

#	1 Minute Period Starting	Meas'd Leq (dBA)	√ or X	Other Noise Sources	COMMENTS
1	8:01:00	55.2			
2	8:02:00	59.3			3 auto NB on Prestwick Hollow Dr.
3	8:03:00	62.1			2 auto NB on Prestwick Hollow Dr.
4	8:04:00	65.8			2 auto NB on Prestwick Hollow Dr.
5	8:05:00	63.5			3 auto NB on Prestwick Hollow Dr.
6	8:06:00	62.3			1 auto NB on Prestwick Hollow Dr.
7	8:07:00	63.0			
8	8:08:00	62.2			1 auto NB on Prestwick Hollow Dr.
9	8:09:00	59.2			1 auto NB on Prestwick Hollow Dr.
10	8:10:00	61.5			1 auto NB on Prestwick Hollow Dr.
11	8:11:00	61.1			
12	8:12:00	62.5			1 heavy truck SB on Prestwick Hollow Dr.
13	8:13:00	59.4			3 auto SB on Prestwick Hollow Dr.
14	8:14:00	63.2			2 auto NB on Prestwick Hollow Dr.
15	8:15:00	60.4			2 auto NB on Prestwick Hollow Dr.
16	8:16:00	61.9			1 auto NB on Prestwick Hollow Dr.
17	8:17:00	62.0			2 auto NB on Prestwick Hollow Dr.
18	8:18:00	61.1			1 auto NB and 2 auto SB on Prestwick Hollow Dr.
19	8:19:00	62.5			1 auto NB on Prestwick Hollow Dr.
20	8:20:00	61.2			1 auto NB on Prestwick Hollow Dr.
21	8:21:00	61.9			
22	8:22:00	60.6			
23	8:23:00	61.8			2 auto NB on Prestwick Hollow Dr.
24	8:24:00	59.0			1 auto NB on Prestwick Hollow Dr.
25	8:25:00	58.9			1 auto and 1 heavy truck NB on Prestwick Hollow Dr.
26	8:26:00	61.5			1 auto SB on Prestwick Hollow Dr.
27	8:27:00	61.9			
28	8:28:00	64.2			
29	8:29:00	62.7			3 auto NB on Prestwick Hollow Dr.
30	8:30:00	62.8			3 auto NB on Prestwick Hollow Dr.

TOTAL Leq = 61.9 dBA

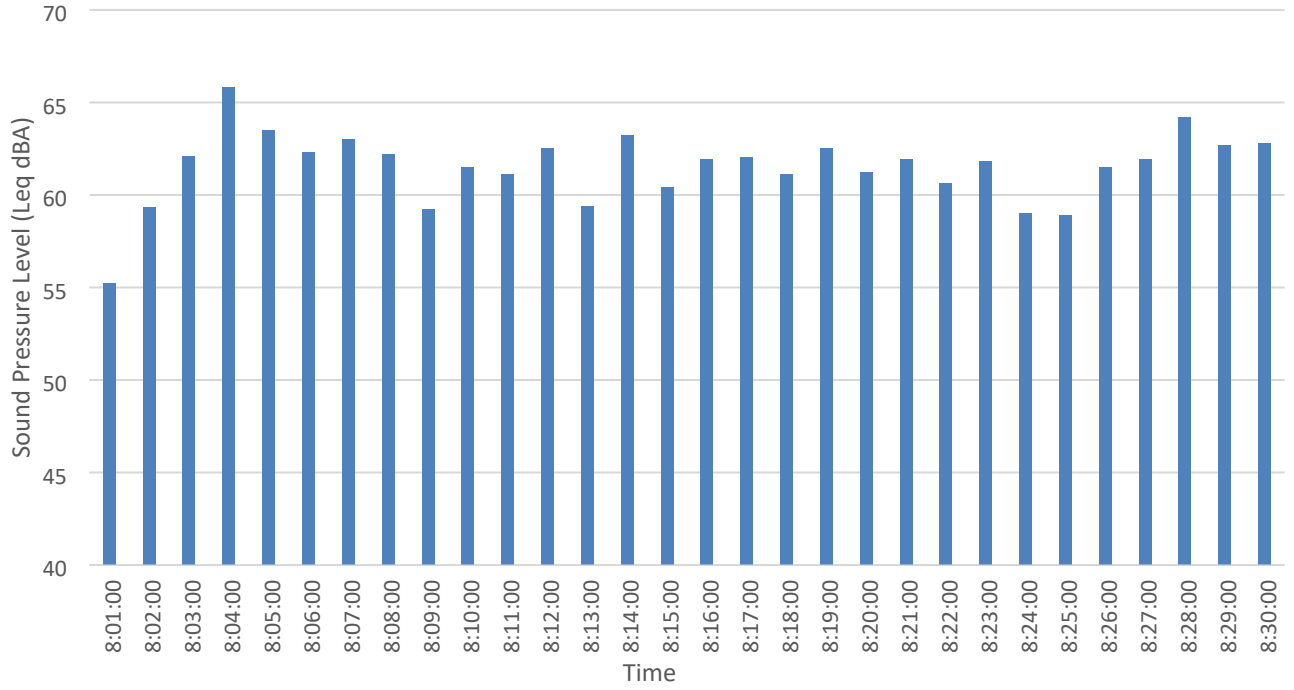
SUBSET Leq =

√ = Other sources contributed to Leq X = Exclude period - contaminated by non-characteristic sources

>> ADD SKETCH AND WEATHER CONDITIONS TO REVERSE OR OTHER SHEET <<



Measured Sound Pressure Level ML-1





#	Eastbound				Westbound			
	Auto	Med	Hvy	Motorcycle	Auto	Med	Hvy	Motorcycle
1	18	0	2					
2	15	0	0					
3	39	0	3					
4	10	0	0					
5	51	1	3					
6	13	0	1					
7	41	1	2					
8	13	0	1					
9	41	0	1					
10	25	0	1					
11	11	0	0					
12	46	0	2					
13	16	0	0					
14	40	1	2					
15	13	0	2					
16					31	0	2	
17					18	0	0	
18					42	1	2	
19					18	0	0	
20					42	0	0	
21					23	0	1	
22					43	1	0	
23					25	0	0	
24					14	0	0	
25					42	0	4	
26					13	0	0	
27					48	0	3	
28					20	0	1	
29					36	0	2	
30					29	0	2	



SHORT-TERM TRAFFIC NOISE MONITORING LOG SHEET

Reading: ML-2

Project Description: 10226441 - BMCD US380 Spur399 SCH ENV

Noise Source: US 380 – University Drive Traffic Date: Dec. 14, 2021 Personnel: RMB

Equipment	Type	Serial #
Sound Level Meter	Larson Davis	824A2636
Microphone/Preamp	Larson Davis 2541; PRM902	7490
Calibrator	Larson Davis CAL200	2618

SLM SETTINGS (circle one)

FAST

SLOW

WEIGHTING (circle one)

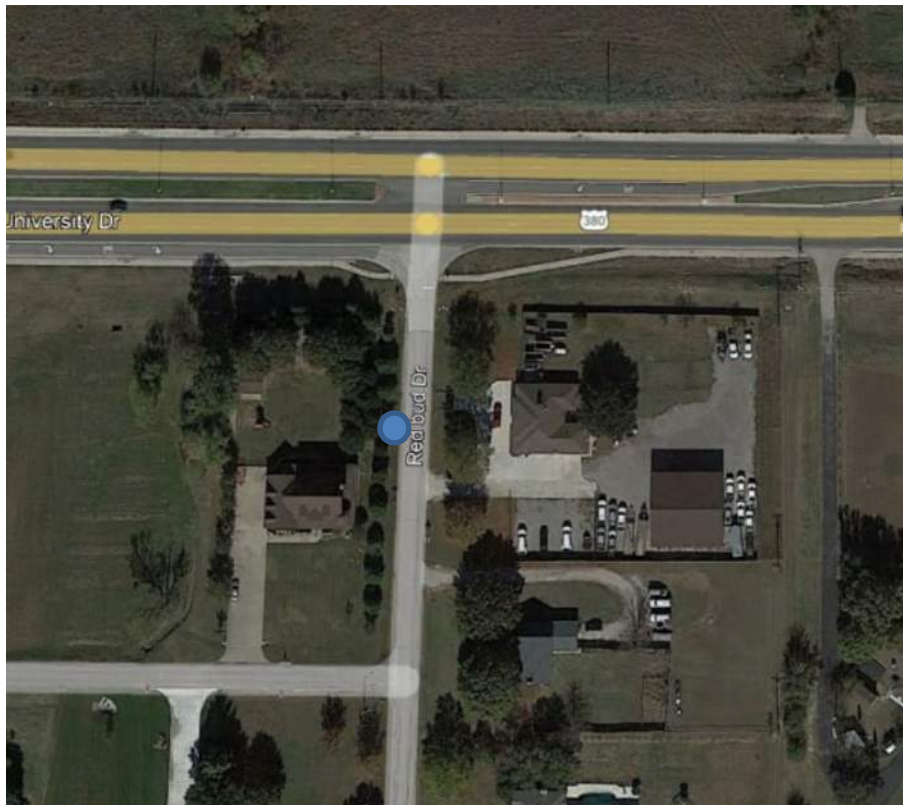
A

Lin.

Location Description: Location ML-2 – US 380 University Drive

SITE SKETCH: Including noise source, receptors, reference distances, North arrow, wind direction arrow, terrain and shielding, roadway profile, and direct lines of sight:

SLM placed on south side of roadway, ~175ft from edge of nearest travel lane of US 380 and 5ft from edge of SB lane of Red Bud Drive. Acceptable line-of-sight. Residence to NE of measurement location had board-on-board fence.



Posted speed 55 mph. Free-flowing traffic at speed. Traffic noise dominant. Some traffic noise due to vehicle pass-bys on Red Bud Dr (30 mph posted) – 70-75 dBA pass-by.



Start Time:

8:51:00 AM PM

Stop Time:

9:21:00 AM PM

Duration:

30 minutes

Wind Speed/Direction: 9 mph S

Percentiles: _____

Temperature: 57-64 F

Humidity: 96% RH (Light fog)

Calibration results before: _____ 114.2 dBA and after _____ 114.1 dBA

Traffic Count Roadway: US 380 – University Drive EB (Top Row) and WB (Bottom Row)

Autos	Medium Trucks	Heavy Trucks	Buses	Motorcycles
317 per 15 minutes	4 per 15 minutes	17 per 15 minutes	---	1 per 15 minutes
324 per 15 minutes	14 per 15 minutes	12 per 15 minutes	1 per 15 minutes	----

***Note roadway direction in table**



SHORT-TERM TRAFFIC NOISE MONITORING LOG SHEET

PROJECT: 10226441 - BMCD US380 Spur399 SCH ENV

JOB NO.: 10226441

SITE/READING NO.: File 4

PERSONNEL: RMB

LOCATION/ADDRESS: Location ML-2

DATE: 12/14/2021

#	1 Minute Period Starting	Meas'd Leq (dBA)	v or X	Other Noise Sources	COMMENTS
1	8:51:00	62.1			
2	8:52:00	58.4			
3	8:53:00	63.1			
4	8:54:00	58.4			
5	8:55:00	64.4			1 auto on Red Bud Drive
6	8:56:00	61.5			
7	8:57:00	64.2			
8	8:58:00	61.2			
9	8:59:00	58.8			
10	9:00:00	62.9			
11	9:01:00	60.5			Wind / leaves, distant plane
12	9:02:00	62.3			1 auto on Red Bud Drive
13	9:03:00	60.3			1 auto on Red Bud Drive, Distant plane
14	9:04:00	64.0			1 auto on Red Bud Drive
15	9:05:00	61.3			Wind / leaves
16	9:06:00	57.1			
17	9:07:00	66.2			1 auto on Red Bud Drive
18	9:08:00	60.5			
19	9:09:00	62.8			
20	9:10:00	59.0			
21	9:11:00	59.9			
22	9:12:00	60.8			1 auto on Red Bud Drive
23	9:13:00	65.4			1 auto on Red Bud Drive
24	9:14:00	61.2			
25	9:15:00	56.2			
26	9:16:00	63.8			3 auto on Red Bud Drive
27	9:17:00	62.0			2 auto on Red Bud Drive
28	9:18:00	63.3			
29	9:19:00	58.5			
30	9:20:00	62.5			1 auto on Red Bud Drive

TOTAL Leq = 62.1 dBA

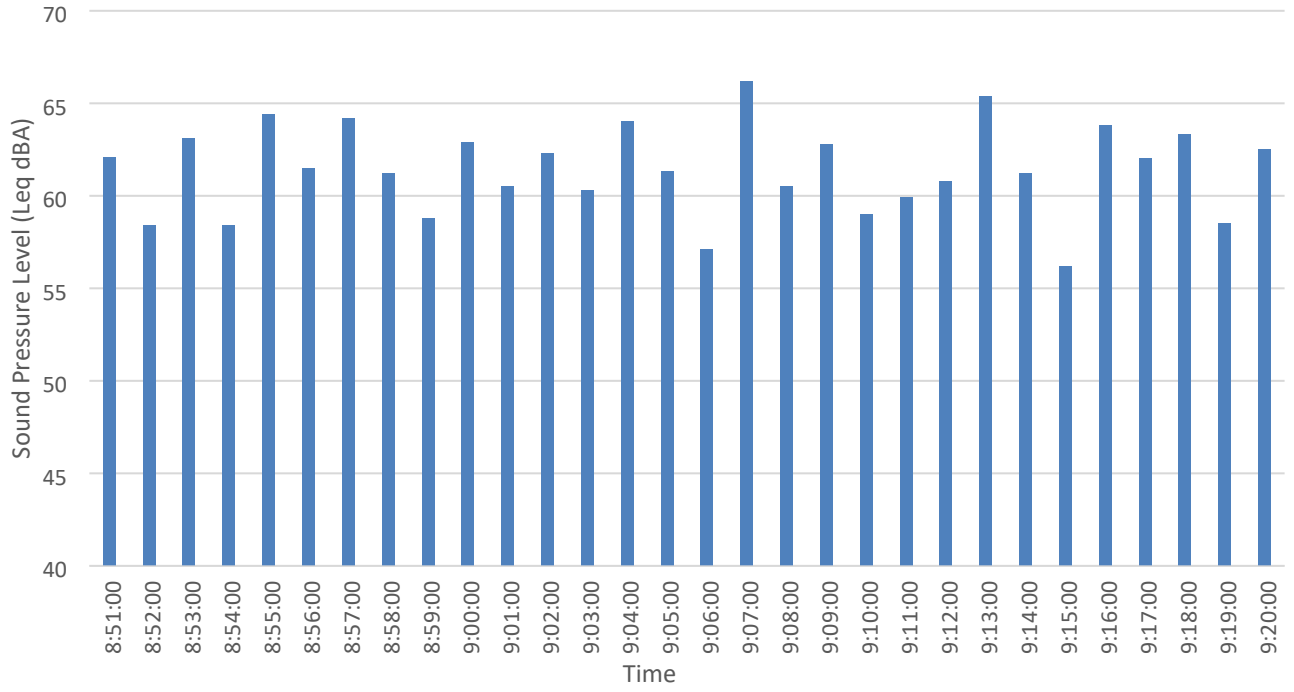
SUBSET Leq =

v = Other sources contributed to Leq X = Exclude period - contaminated by non-characteristic sources

>> ADD SKETCH AND WEATHER CONDITIONS TO REVERSE OR OTHER SHEET <<



Measured Sound Pressure Level ML-2





#	Eastbound				Westbound			
	Auto	Med	Hvy	Motorcycle	Auto	Med	Hvy	Motorcycle
1	14	0	2	0				
2	12	0	1	0				
3	27	0	4	0				
4	12	0	1	0				
5	47	1	5	0				
6	14	0	0	0				
7	27	0	1	1				
8	10	0	0	0				
9	33	0	0	0				
10	15	1	1	0				
11	27	0	0	0				
12	26	2	1	0				
13	9	0	0	0				
14	25	0	1	0				
15	14	0	0	0				
16					10	0	0	
17					20	2	1	
18					26	0	3	
19					26	1	3	
20					25	0	2	
21					8	1	0	
22					31	2	1	
23					10	0	0	
24					35	2	0	
25					22	1	0	
26					11	1	1	
27					12	0	0	
28					34	2	0	
29					18	1	0	
30					36	1	1	



SHORT-TERM TRAFFIC NOISE MONITORING LOG SHEET

Reading: ML-3

Project Description: 10226441 - BMCD US380 Spur399 SCH ENV

Noise Source: US 380 – University Drive Traffic Date: Dec. 14, 2021 Personnel: RMB

Equipment	Type	Serial #
Sound Level Meter	Larson Davis	824A2636
Microphone/Preamp	Larson Davis 2541; PRM902	7490
Calibrator	Larson Davis CAL200	2618

SLM SETTINGS (circle one)

FAST

SLOW

WEIGHTING (circle one)

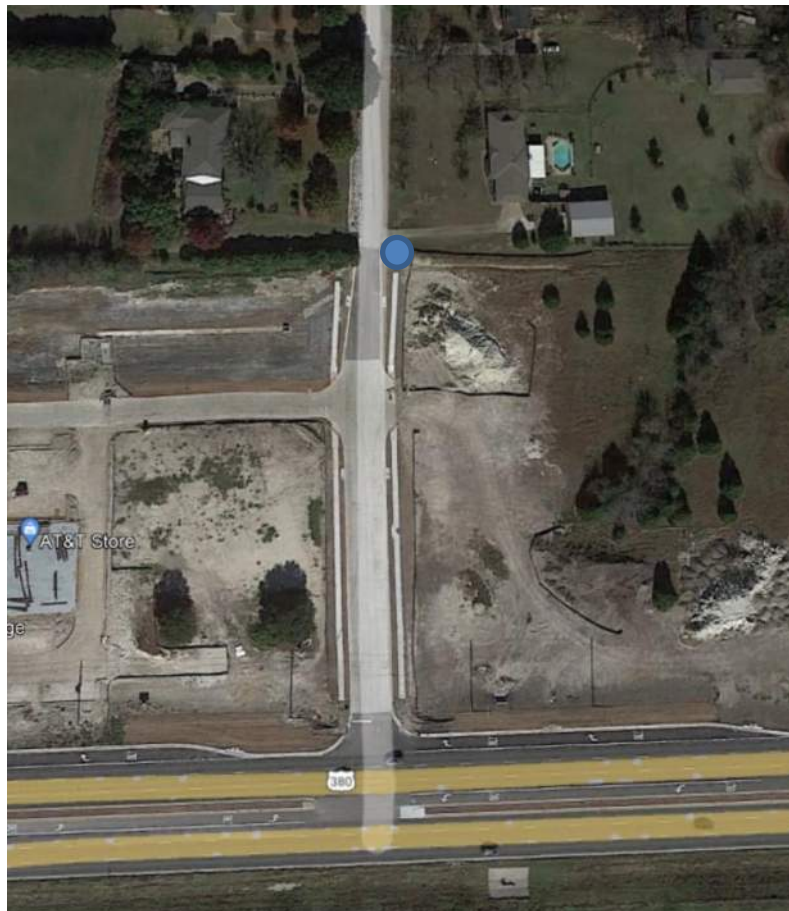
A

Lin.

Location Description: Location ML-3 – US 380 University Drive

SITE SKETCH: Including noise source, receptors, reference distances, North arrow, wind direction arrow, terrain and shielding, roadway profile, and direct lines of sight:

SLM placed on north side of roadway, ~465ft from edge of nearest travel lane of US 380 and 5ft from edge of Hill Top Drive. Acceptable line-of-sight, but slope downward with increasing distance from roadway.





Posted speed 55 mph. Traffic stops at signal light when triggered by traffic turning onto/from Hill Top Drive ; as a result, traffic queues. Some traffic noise due to vehicle pass-bys on Hill Top Drive (30 mph posted), as well as limited construction noise.

Start Time: 9:39:00 AM PM Stop Time: 10:08:00 AM PM Duration: 30 minutes

Wind Speed/Direction: 9 mph S Percentiles: _____

Temperature: 57-64 F Humidity: 96% RH (Partly cloudy)

Calibration results before: _____ 114.2 dBA and after _____ 114.1 dBA

Traffic Count Roadway: US 380 – University Drive EB (Top Row) and WB (Bottom Row)

Autos	Medium Trucks	Heavy Trucks	Buses	Motorcycles
368 per 15 minutes	11 per 15 minutes	15 per 15 minutes	---	----
367 per 15 minutes	6 per 15 minutes	15 per 15 minutes	2 per 15 minutes	----

***Note roadway direction in table**



SHORT-TERM TRAFFIC NOISE MONITORING LOG SHEET

PROJECT: 10226441 - BMCD US380 Spur399 SCH ENV
 JOB NO.: 10226441

SITE/READING NO.: File 5

PERSONNEL: RMB

LOCATION/ADDRESS: Location ML-3

DATE: 12/14/2021

#	1 Minute Period Starting	Meas'd Leq (dBA)	v or X	Other Noise Sources	COMMENTS
1	9:39:00	64.4			1 auto Hill Top Drive, red light at end
2	9:40:00	58.2			Vehicle acceleration (green light)
3	9:41:00	60.6			Red light, wind, horn
4	9:42:00	56.7			
5	9:43:00	59.3			
6	9:44:00	58.0			
7	9:45:00	61.6			
8	9:46:00	59.2			1 auto Hill Top Drive
9	9:47:00	58.7			Red light
10	9:48:00	57.0			Green light (acceleration)
11	9:49:00	61.0			
12	9:50:00	67.1			2 auto Hill Top Drive
13	9:51:00	61.1			red light
14	9:52:00	59.9			2 auto Hill Top Drive, green light (acceleration)
15	9:53:00	63.2			1 auto Hill Top Drive
16	9:54:00	63.3			Green light (acceleration)
17	9:55:00	60.7			1 auto Hill Top Drive, red light
18	9:56:00	68.7			1 auto Hill Top Drive, green light (acceleration)
19	9:57:00	60.4			Red light, wind
20	9:58:00	60.1			
21	9:59:00	62.1			1 auto Hill Top Drive, red light
22	10:00:00	66.6			1 auto Hill Top Drive, green light (acceleration)
23	10:01:00	63.9			Red light
24	10:02:00	58.2			Green light (acceleration)
25	10:03:00	60.2			Red light
26	10:04:00	62.4			Green light (acceleration)
27	10:05:00	57.4			Red light, green light (acceleration)
28	10:06:00	62.6			
29	10:07:00	62.9			1 auto Hill Top Drive, bulldozer
30	10:08:00	63.3			1 auto Hill Top Drive, bulldozer

TOTAL Leq = 62.4 dBA

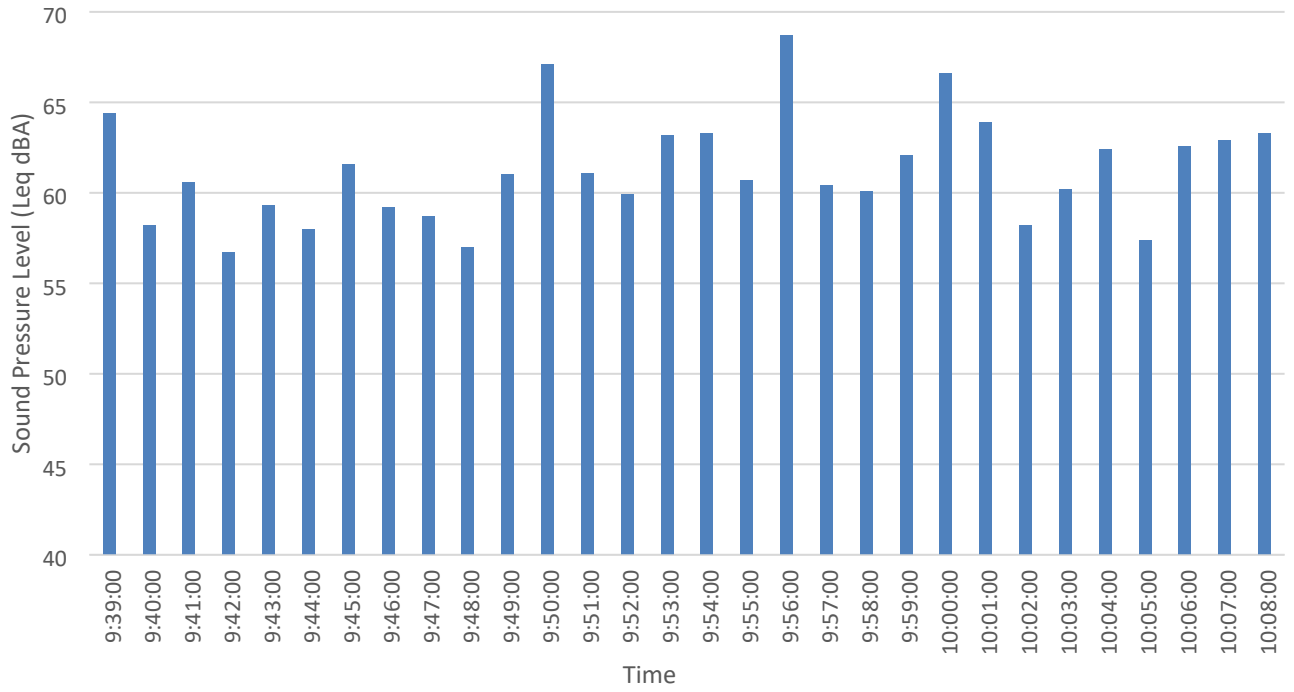
SUBSET Leq =

v = Other sources contributed to Leq X = Exclude period - contaminated by non-characteristic sources

>> ADD SKETCH AND WEATHER CONDITIONS TO REVERSE OR OTHER SHEET <<



Measured Sound Pressure Level ML-3





#	Eastbound				Westbound			
	Auto	Med	Hvy	Motorcycle	Auto	Med	Hvy	Motorcycle
1					32	1	3	
2					17	0	0	
3					25	0	2	
4					19	0	0	
5					31	0	1	
6					10	0	0	
7					47	2	2	
8					10	0	0	
9					40	1	1	
10					10	0	0	
11					27	0	2	
12					9	0	1	
13					34	2	1	
14					12	0	0	
15					44	0	2	
16	40	1	0					
17	15	0	1					
18	26	0	0					
19	23	2	1					
20	21	1	2					
21	14	0	0					
22	39	2	2					
23	9	0	0					
24	27	1	3					
25	17	1	2					
26	20	0	1					
27	24	1	0					
28	27	0	3					
29	20	1	0					
30	46	1	0					



SHORT-TERM TRAFFIC NOISE MONITORING LOG SHEET

Reading: ML-4

Project Description: 10226441 - BMCD US380 Spur399 SCH ENV

Noise Source: US 380 – University Drive Traffic Date: Dec. 14, 2021 Personnel: RMB

Equipment	Type	Serial #
Sound Level Meter	Larson Davis	824A2636
Microphone/Preamplifier	Larson Davis 2541; PRM902	7490
Calibrator	Larson Davis CAL200	2618

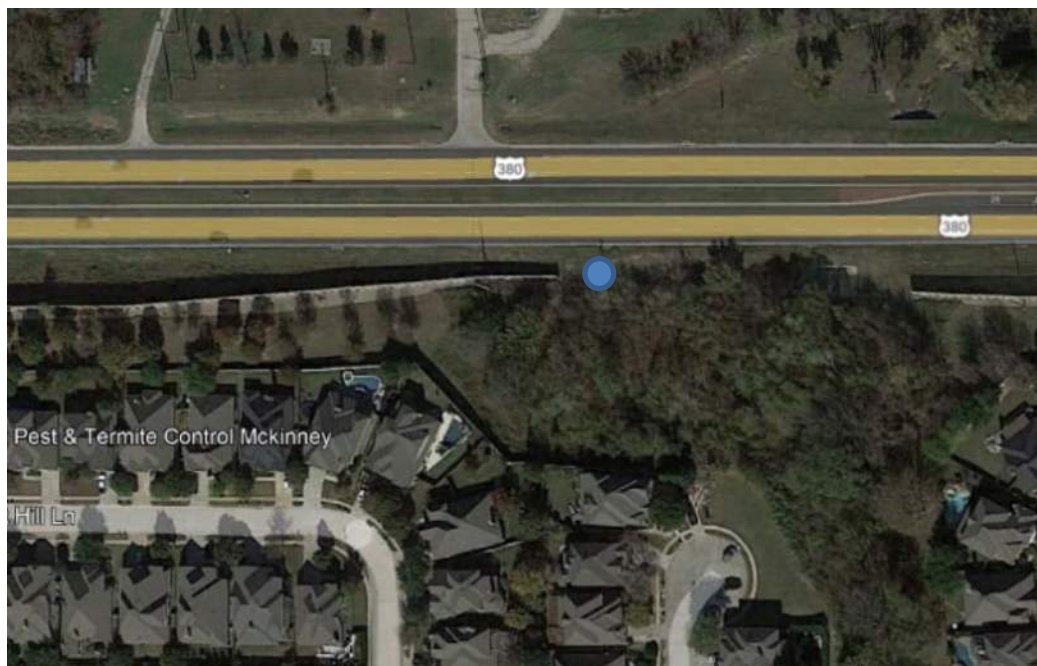
SLM SETTINGS (circle one) FAST SLOW

WEIGHTING (circle one) A Lin.

Location Description: Location ML-4 – US 380 University Drive

SITE SKETCH: Including noise source, receptors, reference distances, North arrow, wind direction arrow, terrain and shielding, roadway profile, and direct lines of sight:

SLM placed on south side of roadway, ~30-35ft from edge of nearest travel lane of US 380 and 10ft from existing highway noise barrier. Microphone about tire height to traffic. Traffic queues for signal light to east. Good line-of-sight, roadway slopes upward towards west.





Start Time:

10:34:32 (AM) PM

Stop Time:

11:03:32 (AM) PM

Duration:

30 minutes

Wind Speed/Direction: 9 mph S

Percentiles: _____

Temperature: 57-64 F

Humidity: 96% RH (Partly cloudy)

Calibration results before: _____ 114.2 dBA and after _____ 114.1 dBA

Traffic Count Roadway: US 380 – University Drive EB (Top Row) and WB (Bottom Row)

Autos	Medium Trucks	Heavy Trucks	Buses	Motorcycles
350 per 15 minutes	11 per 15 minutes	14 per 15 minutes	3 per 15 minutes	1 per 15 minutes
294 per 15 minutes	7 per 15 minutes	21 per 15 minutes	----	1 per 15 minutes

***Note roadway direction in table**



SHORT-TERM TRAFFIC NOISE MONITORING LOG SHEET

PROJECT: 10226441 - BMCD US380 Spur399 SCH ENV

JOB NO.: 10226441

SITE/READING NO.: File 6

PERSONNEL: RMB

LOCATION/ADDRESS: Location ML-4

DATE: 12/14/2021

#	1 Minute Period Starting	Meas'd Leq (dBA)	v or X	Other Noise Sources	COMMENTS
1	10:34:32	69.5			48-51 dBA ambient (no traffic)
2	10:35:32	65.6			
3	10:36:32	68.2			
4	10:37:32	63.1			
5	10:38:32	71.8			
6	10:39:32	69.0			
7	10:40:32	68.4			
8	10:41:32	67.9			
9	10:42:32	71.3			
10	10:43:32	63.8			
11	10:44:32	71.7			
12	10:45:32	62.6			
13	10:46:32	69.2			
14	10:47:32	65.7			
15	10:48:32	77.7			Ambulance (sirens)
16	10:49:32	67.1			
17	10:50:32	68.8			
18	10:51:32	65.8			
19	10:52:32	68.9			
20	10:53:32	66.4			
21	10:54:32	68.7			
22	10:55:32	65.2			Light cycle – traffic movement not significant
23	10:56:32	71.8			
24	10:57:32	65.7			
25	10:58:32	71.0			
26	10:59:32	61.9			
27	11:00:32	68.2			
28	11:01:32	65.0			
29	11:02:32	69.4			
30	11:03:32	66.9			

TOTAL Leq = 69.2 dBA

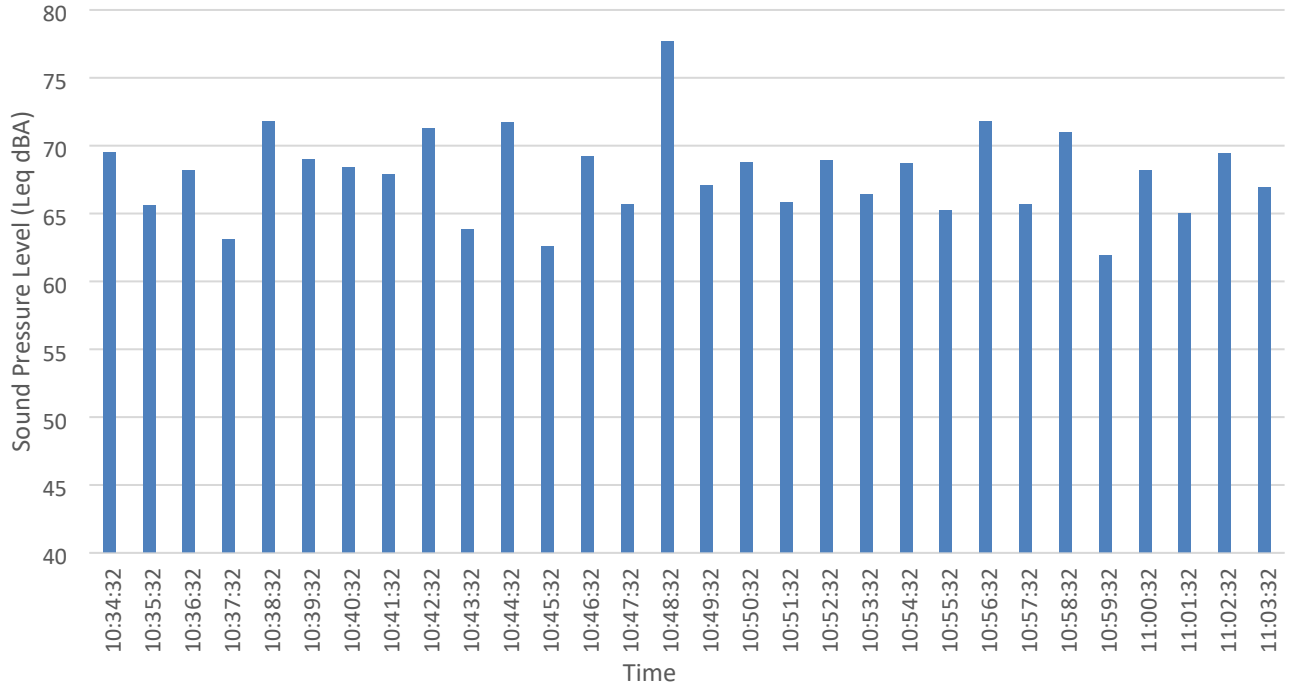
SUBSET Leq =

v = Other sources contributed to Leq X = Exclude period - contaminated by non-characteristic sources

>> ADD SKETCH AND WEATHER CONDITIONS TO REVERSE OR OTHER SHEET <<



Measured Sound Pressure Level ML-4





#	Eastbound				Westbound			
	Auto	Med	Hvy	Motorcycle	Auto	Med	Hvy	Motorcycle
1	24	0	1	0				
2	30	0	0	0				
3	19	2	3	0				
4	29	2	0	0				
5	24	0	2	0				
6	31	2	0	0				
7	7	1	0	0				
8	28	1	0	0				
9	11	0	1	0				
10	10	0	0	0				
11	49	1	1	0				
12	10	0	0	0				
13	36	1	2	0				
14	8	0	0	0				
15	34	1	4	1				
16					20	0	0	0
17					23	2	4	0
18					10	0	0	1
19					6	1	0	0
20					10	0	0	0
21					49	1	3	0
22					3	0	0	0
23					45	2	5	0
24					18	0	0	0
25					26	0	3	0
26					11	0	0	0
27					24	0	2	0
28					5	0	0	0
29					34	1	4	0
30					10	0	0	0



SHORT-TERM TRAFFIC NOISE MONITORING LOG SHEET

Reading: ML-5

Project Description: 10226441 - BMCD US380 Spur399 SCH ENV

Noise Source: US 380 – University Drive Traffic Date: Dec. 14, 2021 Personnel: RMB

Equipment	Type	Serial #
Sound Level Meter	Larson Davis	824A2636
Microphone/Preamp	Larson Davis 2541; PRM902	7490
Calibrator	Larson Davis CAL200	2618

SLM SETTINGS (circle one)

FAST

SLOW

WEIGHTING (circle one)

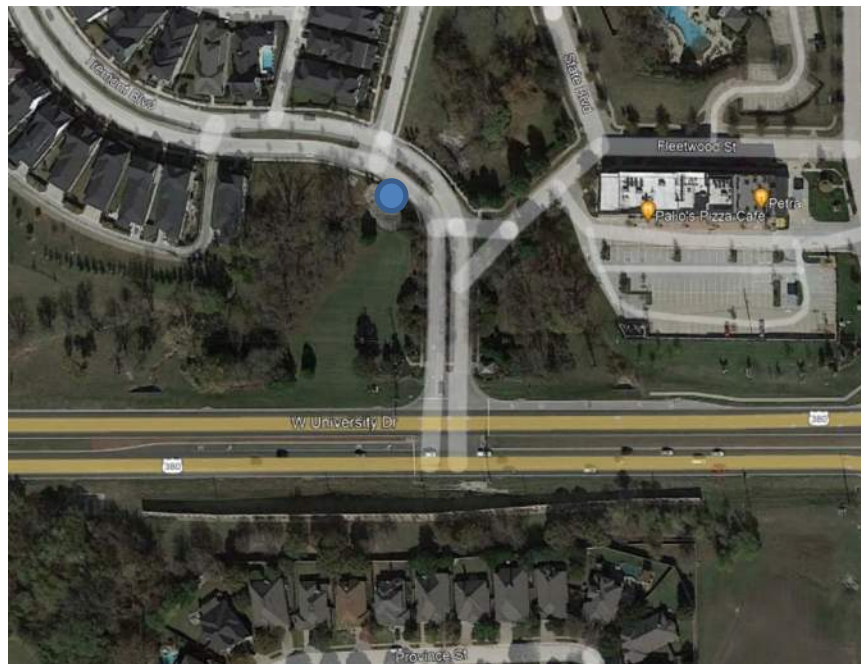
A

Lin.

Location Description: Location ML-5 – US 380 University Drive

SITE SKETCH: Including noise source, receptors, reference distances, North arrow, wind direction arrow, terrain and shielding, roadway profile, and direct lines of sight:

SLM placed on north side of roadway, ~335ft from edge of nearest travel lane of US 380. Generally acceptable line-of-site to WB traffic, but relatively shielded to EB traffic due to downhill slope away from roadway, especially farthest two lanes – no tires visible. Traffic queues for signal light.





Start Time:

11:26:00 AM PM

Stop Time:

11:55:00 AM PM

Duration:

30 minutes

Wind Speed/Direction: 9 mph S

Percentiles: _____

Temperature: 57-64 F

Humidity: 96% RH (Partly cloudy)

Calibration results before: _____ 114.2 dBA and after _____ 114.1 dBA

Traffic Count Roadway: US 380 – University Drive EB (Top Row) and WB (Bottom Row)

Autos	Medium Trucks	Heavy Trucks	Buses	Motorcycles
277 per 15 minutes	5 per 15 minutes	18 per 15 minutes	----	----
264 per 15 minutes	2 per 15 minutes	16 per 15 minutes	----	----

***Note roadway direction in table**



SHORT-TERM TRAFFIC NOISE MONITORING LOG SHEET

PROJECT: 10226441 - BMCD US380 Spur399 SCH ENV
 JOB NO.: 10226441

SITE/READING NO.: File 7

PERSONNEL: RMB

LOCATION/ADDRESS: Location ML-5

DATE: 12/14/2021

#	1 Minute Period Starting	Meas'd Leq (dBA)	v or X	Other Noise Sources	COMMENTS
1	11:26:00	58.7			
2	11:27:00	58.2			
3	11:28:00	57.7			
4	11:29:00	58.6			
5	11:30:00	59.1			
6	11:31:00	60.1			
7	11:32:00	59.0			
8	11:33:00	57.7			
9	11:34:00	58.5			
10	11:35:00	61.5			
11	11:36:00	59.6			
12	11:37:00	59.2			
13	11:38:00	60.6			
14	11:39:00	57.1			
15	11:40:00	56.5			
16	11:41:00	59.4			
17	11:42:00	61.8			
18	11:43:00	61.2			
19	11:44:00	61.5			
20	11:45:00	56.7			
21	11:46:00	61.0			
22	11:47:00	59.0			
23	11:48:00	60.7			
24	11:49:00	57.5			
25	11:50:00	58.3			
26	11:51:00	59.4			
27	11:52:00	58.8			
28	11:53:00	57.9			
29	11:54:00	58.9			
30	11:55:00	58.8			wind

TOTAL Leq = 59.3 dBA

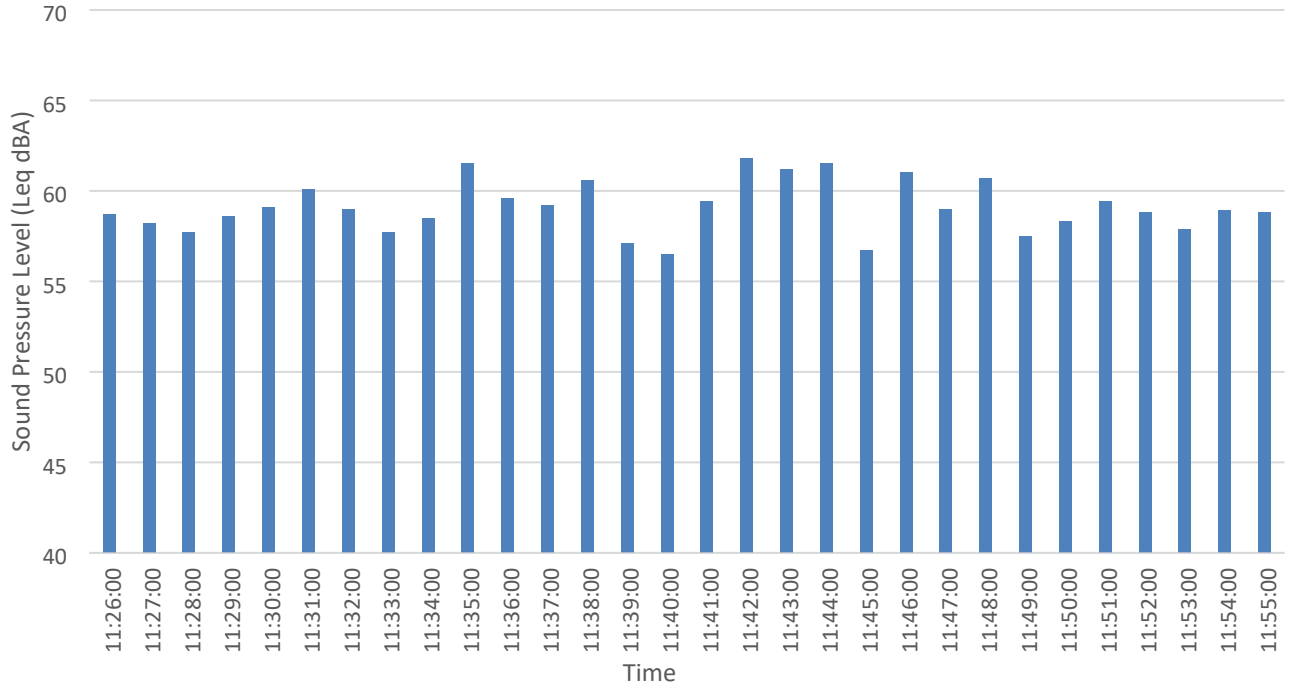
SUBSET Leq =

v = Other sources contributed to Leq X = Exclude period - contaminated by non-characteristic sources

>> ADD SKETCH AND WEATHER CONDITIONS TO REVERSE OR OTHER SHEET <<



Measured Sound Pressure Level ML-5





#	Eastbound				Westbound			
	Auto	Med	Hvy	Motorcycle	Auto	Med	Hvy	Motorcycle
1	34	0	0					
2	4	1	0					
3	35	0	2					
4	5	0	0					
5	31	0	2					
6	6	0	0					
7	26	0	2					
8	2	0	0					
9	35	2	2					
10	0	0	0					
11	42	1	3					
12	2	0	0					
13	25	0	3					
14	4	1	0					
15	26	0	4					
16					4	0	0	
17					34	0	3	
18					8	0	1	
19					23	1	0	
20					12	0	0	
21					23	0	2	
22					14	0	0	
23					31	0	3	
24					4	0	0	
25					32	0	5	
26					1	0	0	
27					34	0	1	
28					1	0	0	
29					41	1	1	
30					2	0	0	



SHORT-TERM TRAFFIC NOISE MONITORING LOG SHEET

Reading: ML-6

Project Description: 10226441 - BMCD US380 Spur399 SCH ENV

Noise Source: US 380 – University Drive Traffic Date: Dec. 14, 2021 Personnel: RMB

Equipment	Type	Serial #
Sound Level Meter	Larson Davis	824A2636
Microphone/Preamp	Larson Davis 2541; PRM902	7490
Calibrator	Larson Davis CAL200	2618

SLM SETTINGS (circle one)

FAST

SLOW

WEIGHTING (circle one)

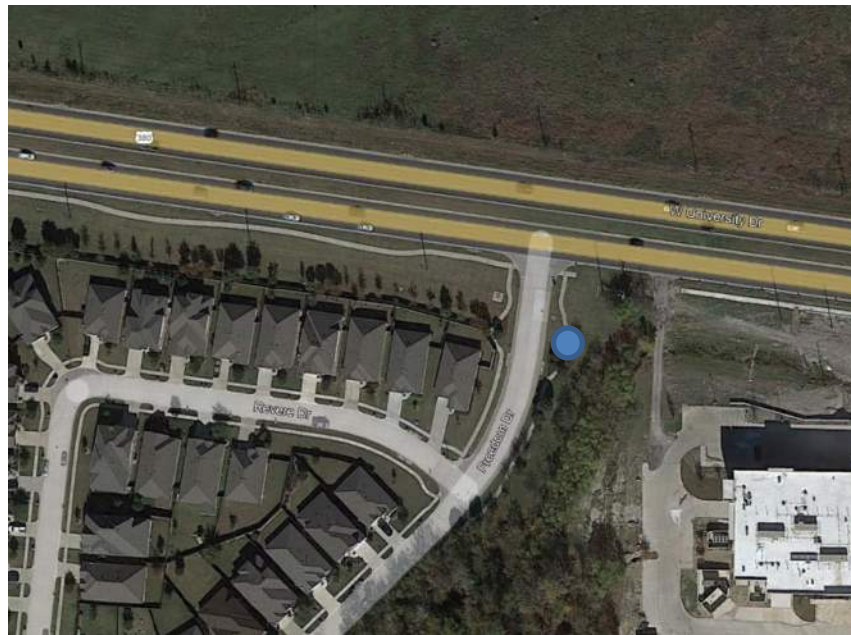
A

Lin.

Location Description: Location ML-6 – US 380 University Drive

SITE SKETCH: Including noise source, receptors, reference distances, North arrow, wind direction arrow, terrain and shielding, roadway profile, and direct lines of sight:

SLM placed on south side of roadway, ~85-90ft from edge of nearest travel lane of US 380. Good line-of-site.





Start Time:

12:55:00 AM **PM**

Stop Time:

1:24:00 AM **PM**

Duration:

30 minutes

Wind Speed/Direction: 11 mph SSE

Percentiles: _____

Temperature: 66-70 F

Humidity: 90% RH (Partly cloudy)

Calibration results before: _____114.2 dBA and after _____114.1 dBA

Traffic Count Roadway: US 380 – University Drive EB (Top Row) and WB (Bottom Row)

Autos	Medium Trucks	Heavy Trucks	Buses	Motorcycles
317 per 15 minutes	2 per 15 minutes	14 per 15 minutes	----	----
335 per 15 minutes	6 per 15 minutes	21 per 15 minutes	----	----

***Note roadway direction in table**



SHORT-TERM TRAFFIC NOISE MONITORING LOG SHEET

PROJECT: 10226441 - BMCD US380 Spur399 SCH ENV

JOB NO.: 10226441

SITE/READING NO.: File 8

PERSONNEL: RMB

LOCATION/ADDRESS: Location ML-6

DATE: 12/14/2021

#	1 Minute Period Starting	Meas'd Leq (dBA)	v or X	Other Noise Sources	COMMENTS
1	12:55:00	70.5			
2	12:56:00	67.5			
3	12:57:00	71.2			
4	12:58:00	68.0			
5	12:59:00	74.7			
6	13:00:00	63.6			
7	13:01:00	72.4			
8	13:02:00	66.1			
9	13:03:00	70.0			
10	13:04:00	66.1			
11	13:05:00	71.5			
12	13:06:00	66.5			
13	13:07:00	72.3			
14	13:08:00	65.3			
15	13:09:00	71.5			
16	13:10:00	66.5			
17	13:11:00	70.5			
18	13:12:00	66.3			
19	13:13:00	72.4			
20	13:14:00	65.6			
21	13:15:00	72.3			
22	13:16:00	65.1			
23	13:17:00	72.7			
24	13:18:00	66.3			
25	13:19:00	71.3			
26	13:20:00	69.6			
27	13:21:00	72.5			
28	13:22:00	70.3			
29	13:23:00	72.6			
30	13:24:00	67.3			wind

TOTAL Leq = 70.2 dBA

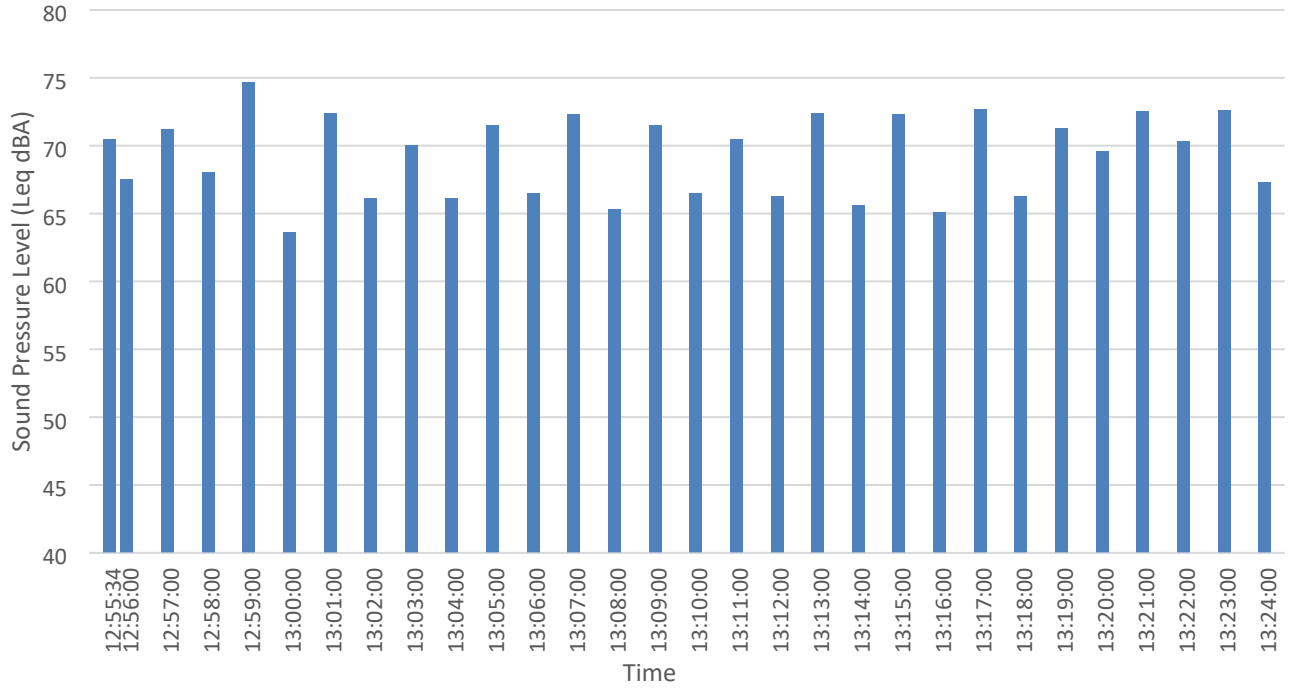
SUBSET Leq =

v = Other sources contributed to Leq X = Exclude period - contaminated by non-characteristic sources

>> ADD SKETCH AND WEATHER CONDITIONS TO REVERSE OR OTHER SHEET <<



Measured Sound Pressure Level ML-6





#	Eastbound				Westbound			
	Auto	Med	Hvy	Motorcycle	Auto	Med	Hvy	Motorcycle
1	10	0	0					
2	38	0	1					
3	3	0	0					
4	35	0	5					
5	8	1	0					
6	41	0	1					
7	8	0	1					
8	34	0	0					
9	13	0	1					
10	28	1	2					
11	6	0	0					
12	38	0	2					
13	17	0	1					
14	29	0	0					
15	9	0	0					
16					22	0	1	
17					30	0	1	
18					24	0	2	
19					26	2	2	
20					8	0	0	
21					30	0	2	
22					10	1	1	
23					21	0	1	
24					9	0	2	
25					51	0	3	
26					10	2	0	
27					34	1	2	
28					11	0	0	
29					35	0	4	
30					14	0	0	



SHORT-TERM TRAFFIC NOISE MONITORING LOG SHEET

Reading: ML-9

Project Description: 10226441 - BMCD US380 Spur399 SCH ENV

Noise Source: TX 123 Date: Dec. 14, 2021 Personnel: RMB

Equipment	Type	Serial #
Sound Level Meter	Larson Davis	824A2636
Microphone/Preamp	Larson Davis 2541; PRM902	7490
Calibrator	Larson Davis CAL200	2618

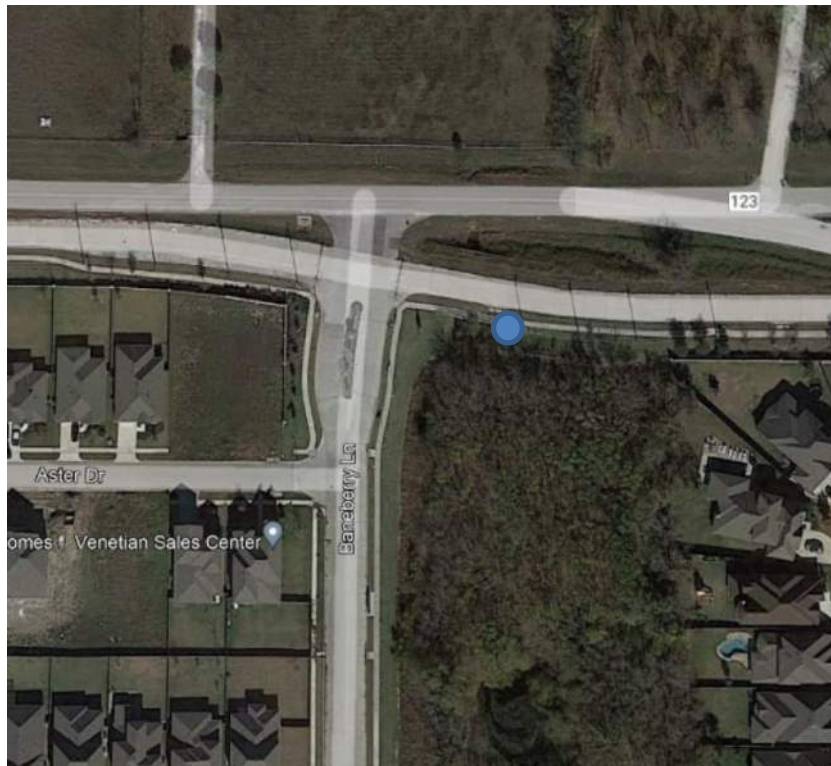
SLM SETTINGS (circle one) FAST SLOW

WEIGHTING (circle one) A Lin.

Location Description: Location ML-9 – TX 123

SITE SKETCH: Including noise source, receptors, reference distances, North arrow, wind direction arrow, terrain and shielding, roadway profile, and direct lines of sight:

SLM placed on south side of roadway (near side walk, ~100ft from edge of nearest travel lane of TX 123. Good line-of-site to WB traffic.





Start Time:

3:27:00 AM **PM**

Stop Time:

3:56:00 AM **PM**

Duration:

30 minutes

Wind Speed/Direction: 9 mph S

Percentiles: _____

Temperature: 57-64 F

Humidity: 96% RH (Partly cloudy)

Calibration results before: _____ 114.2 dBA and after _____ 114.1 dBA

Traffic Count Roadway: TX 123 EB (Top Row) and WB (Bottom Row)

Autos	Medium Trucks	Heavy Trucks	Buses	Motorcycles
87 per 30 minutes	3 per 30 minutes	1 per 30 minutes	----	----
52 per 30 minutes	0 per 30 minutes	1 per 30 minutes	----	----

***Note roadway direction in table**



SHORT-TERM TRAFFIC NOISE MONITORING LOG SHEET

PROJECT: 10226441 - BMCD US380 Spur399 SCH ENV

JOB NO.: 10226441

SITE/READING NO.: File 11

PERSONNEL: RMB

LOCATION/ADDRESS: Location ML-9

DATE: 12/14/2021

#	1 Minute Period Starting	Meas'd Leq (dBA)	v or X	Other Noise Sources	COMMENTS
1	15:27:00	47.3			
2	15:28:00	54.9			
3	15:29:00	54.6			
4	15:30:00	54.8			
5	15:31:00	52.3			
6	15:32:00	56.4			Distant plane
7	15:33:00	55.6			
8	15:34:00	53.4			
9	15:35:00	54.1			
10	15:36:00	54.1			
11	15:37:00	56.1			Distant plane
12	15:38:00	55.6			
13	15:39:00	52.2			
14	15:40:00	55.4			
15	15:41:00	59.3			Trailer noise from pick-up truck
16	15:42:00	55.2			
17	15:43:00	55.1			
18	15:44:00	55.3			
19	15:45:00	53.6			Distant plane
20	15:46:00	57.3			
21	15:47:00	53.0			
22	15:48:00	54.1			Plane
23	15:49:00	52.3			Plane
24	15:50:00	47.0			Flag poles – clanging
25	15:51:00	52.0			
26	15:52:00	56.4			
27	15:53:00	58.4			Distant plane
28	15:54:00	55.8			
29	15:55:00	56.8			
30	15:56:00	57.4			

TOTAL Leq = 55.2 dBA

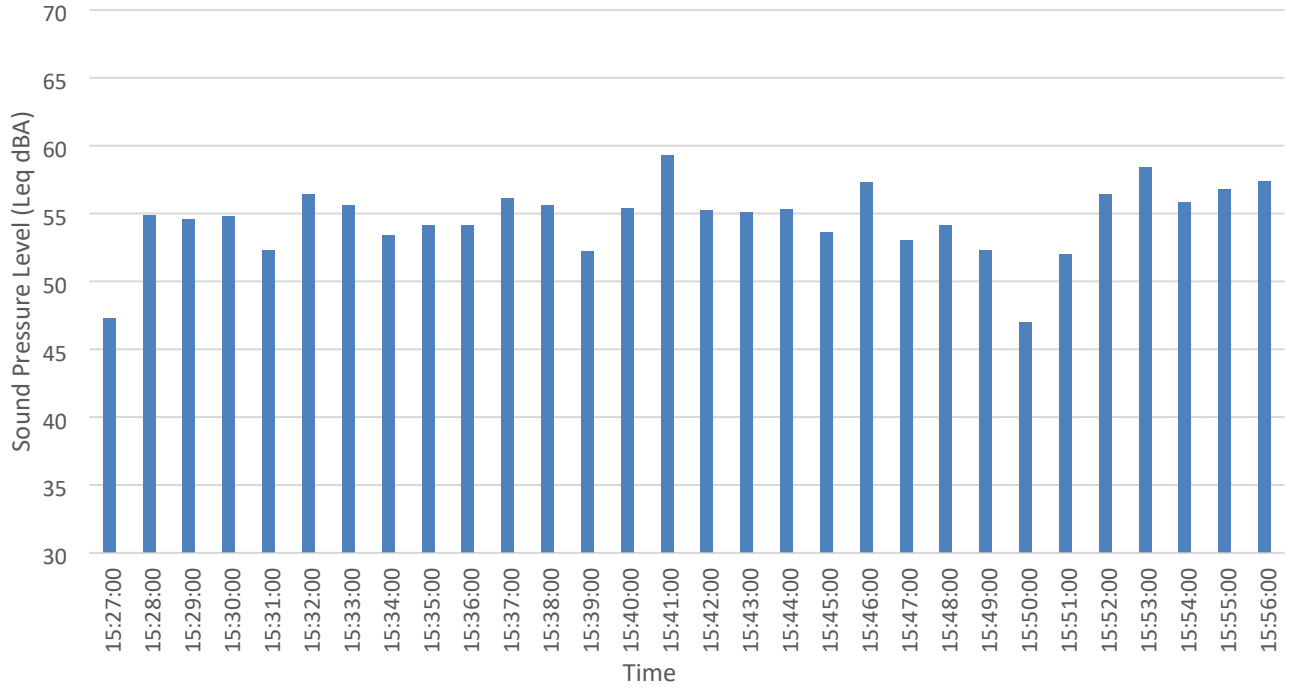
SUBSET Leq =

v = Other sources contributed to Leq X = Exclude period - contaminated by non-characteristic sources

>> ADD SKETCH AND WEATHER CONDITIONS TO REVERSE OR OTHER SHEET <<



Measured Sound Pressure Level ML-9





#	Eastbound				Westbound			
	Auto	Med	Hvy	Motorcycle	Auto	Med	Hvy	Motorcycle
1	2	1	0		0	0	0	
2	3	0	0		1	0	0	
3	1	0	0		5	0	0	
4	4	0	0		1	0	0	
5	2	0	1		1	0	0	
6	5	1	0		1	0	0	
7	2	0	0		2	0	0	
8	3	0	0		1	0	0	
9	3	0	0		5	0	0	
10	4	0	0		2	0	0	
11	2	0	0		4	0	0	
12	3	0	0		2	0	0	
13	3	0	0		1	0	0	
14	2	0	0		3	0	0	
15	4	0	0		3	0	0	
16	3	0	0		1	0	0	
17	6	1	0		0	0	0	
18	3	0	0		4	0	0	
19	3	0	0		2	0	0	
20	2	0	0		0	0	0	
21	2	0	0		1	0	0	
22	3	0	0		0	0	0	
23	0	0	0		0	0	0	
24	2	0	0		0	0	0	
25	4	0	0		1	0	0	
26	6	0	0		2	0	0	
27	2	0	0		2	0	0	
28	3	0	0		1	0	0	
29	1	0	0		4	0	1	
30	4	0	0		2	0	0	



SHORT-TERM TRAFFIC NOISE MONITORING LOG SHEET

Reading: ML-13

Project Description: 10226441 - BMCD US380 Spur399 SCH ENV

Noise Source: TX 1827 Date: Dec. 16, 2021 Personnel: RMB

Equipment	Type	Serial #
Sound Level Meter	Larson Davis	824A2636
Microphone/Preamplifier	Larson Davis 2541; PRM902	7490
Calibrator	Larson Davis CAL200	2618

SLM SETTINGS (circle one)

FAST

SLOW

WEIGHTING (circle one)

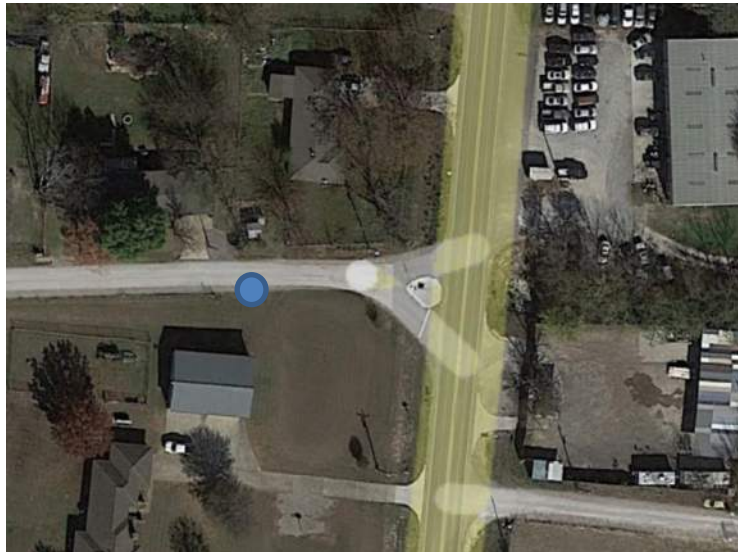
A

Lin.

Location Description: Location ML-13 – TX 1827

SITE SKETCH: Including noise source, receptors, reference distances, North arrow, wind direction arrow, terrain and shielding, roadway profile, and direct lines of sight:

SLM placed along TX 1827, ~115-120ft from edge of nearest travel lane. 40 dBA low. Some noise from auto shop across street.





Start Time:

3:33:41 AM **PM**

Stop Time:

4:03:41 AM **PM**

Duration:

30 minutes

Wind Speed/Direction: 9 mph N

Percentiles: _____

Temperature: 63-70 F

Humidity: 46% RH (partly cloudy)

Calibration results before: _____ 114.0 dBA and after _____ 114.0 dBA

Traffic Count Roadway: TX 1827 SB (Top Row) and NB (Bottom Row)

Autos	Medium Trucks	Heavy Trucks	Buses	Motorcycles
89 per 30 minutes	0 per 30 minutes	7 per 30 minutes	2 per 30 minutes	1 per 30 minutes
114 per 30 minutes	0 per 30 minutes	6 per 30 minutes	1 per 30 minutes	1 per 30 minutes

***Note roadway direction in table**



SHORT-TERM TRAFFIC NOISE MONITORING LOG SHEET

PROJECT: 10226441 - BMCD US380 Spur399 SCH ENV

JOB NO.: 10226441

SITE/READING NO.: File 20

PERSONNEL: RMB

LOCATION/ADDRESS: Location ML-13

DATE: 12/16/2021

#	1 Minute Period Starting	Meas'd Leq (dBA)	v or X	Other Noise Sources	COMMENTS
1	15:33:41	59.9			Heavy car acceleration across street
2	15:34:41	57.1			Plane
3	15:35:41	64.1			Nearby plane
4	15:36:41	63.4			Plane
5	15:37:41	59.5			Plane, banging
6	15:38:41	59.4			2 planes
7	15:39:41	60.5			
8	15:40:41	49.7			
9	15:41:41	57.3			
10	15:42:41	58.8			
11	15:43:41	60.9			Plane
12	15:44:41	58.8			Plane, talking
13	15:45:41	58.6			
14	15:46:41	62.2			Plane, horn, car start
15	15:47:41	64.0			Plane
16	15:48:41	63.4			Car acceleration
17	15:49:41	57.0			Music
18	15:50:41	52.3			
19	15:52:41	55.2			
20	15:53:41	56.9			Loud jet
21	15:54:41	63.1			
22	15:55:41	57.2			
23	15:56:41	60.5			Jet 82 dBA
24	15:57:41	73.4			
25	15:58:41	58.9			
26	15:59:41	57.8			Horn, jet
27	16:00:41	66.3			Distant jet
28	16:01:41	55.5			
29	16:02:41	60.7			Jet, music
30	16:03:41	56.3			Plane

TOTAL Leq = 62.6 dBA

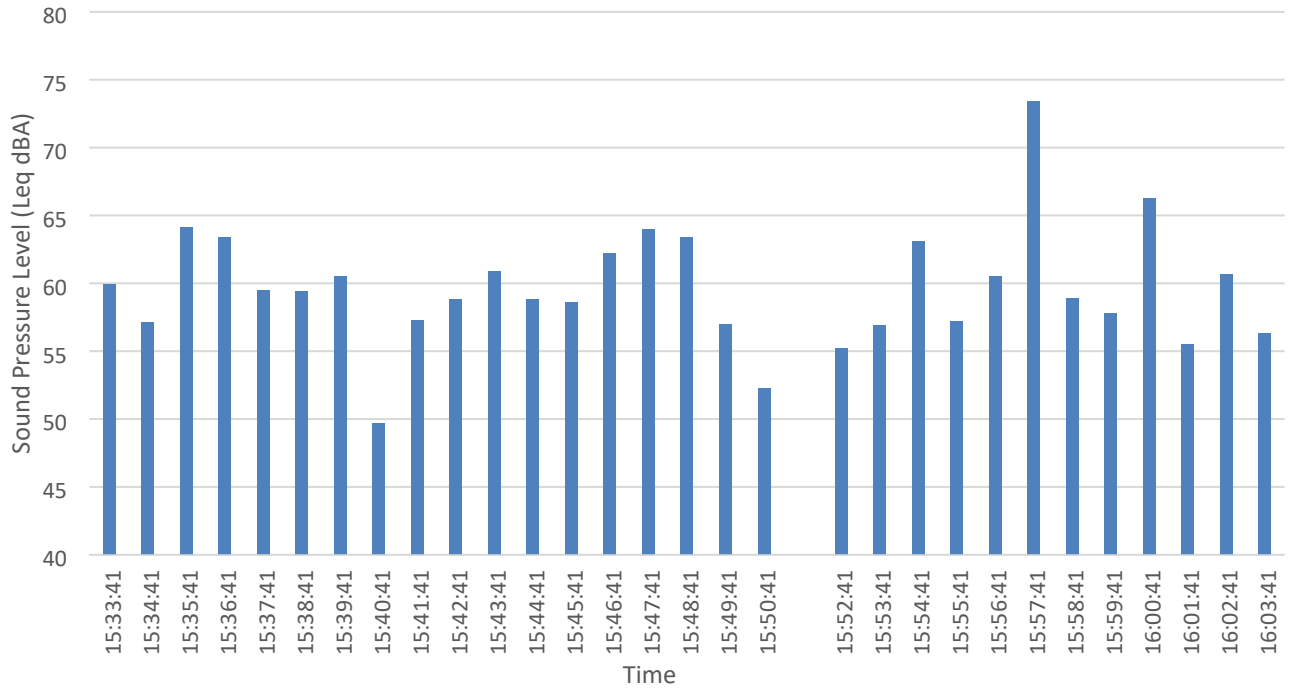
SUBSET Leq =

v = Other sources contributed to Leq X = Exclude period - contaminated by non-characteristic sources

>> ADD SKETCH AND WEATHER CONDITIONS TO REVERSE OR OTHER SHEET <<



Measured Sound Pressure Level ML-13





#	Southbound				Northbound			
	Auto	Med	Hvy	Motorcycle	Auto	Med	Hvy	Motorcycle
1	5	0	0	0	8	0	0	0
2	4	0	0	0	4	0	0	0
3	2	0	1	0	5	0	0	0
4	3	0	0	1	3	0	1	0
5	2	0	0	0	1	0	0	0
6	2	0	0	0	8	0	0	0
7	6	0	0	0	1	0	0	0
8	1	0	0	0	0	0	0	0
9	3	0	0	0	7	0	1	0
10	4	0	0	0	1	0	0	0
11	3	0	0	0	1	0	1	0
12	5	0	0	0	7	0	0	0
13	6	0	1	0	1	0	1	0
14	4	0	1	0	6	0	0	0
15	2	0	0	0	3	0	1	0
16	6	0	0	0	7	0	0	0
17	3	0	1	0	0	0	0	0
18	2	0	0	0	0	0	0	0
19	1	0	0	0	1	0	0	0
20	5	0	1	0	6	0	0	0
21	1	0	2	0	6	0	0	0
22	3	0	0	0	3	0	0	0
23	2	0	0	0	10	0	0	0
24	4	0	0	0	1	0	0	0
25	4	0	0	0	3	0	0	0
26	0	0	0	0	7	0	0	1
27	1	0	0	0	1	0	1	0
28	2	0	0	0	10	0	0	0
29	3	0	0	0	0	0	0	0
30	0	0	0	0	3	0	0	0



SHORT-TERM TRAFFIC NOISE MONITORING LOG SHEET

Reading: ML-14

Project Description: 10226441 - BMCD US380 Spur399 SCH ENV

Noise Source: US 380 Date: Dec. 16, 2021 Personnel: RMB

Equipment	Type	Serial #
Sound Level Meter	Larson Davis	824A2636
Microphone/Preamp	Larson Davis 2541; PRM902	7490
Calibrator	Larson Davis CAL200	2618

SLM SETTINGS (circle one)

FAST

SLOW

WEIGHTING (circle one)

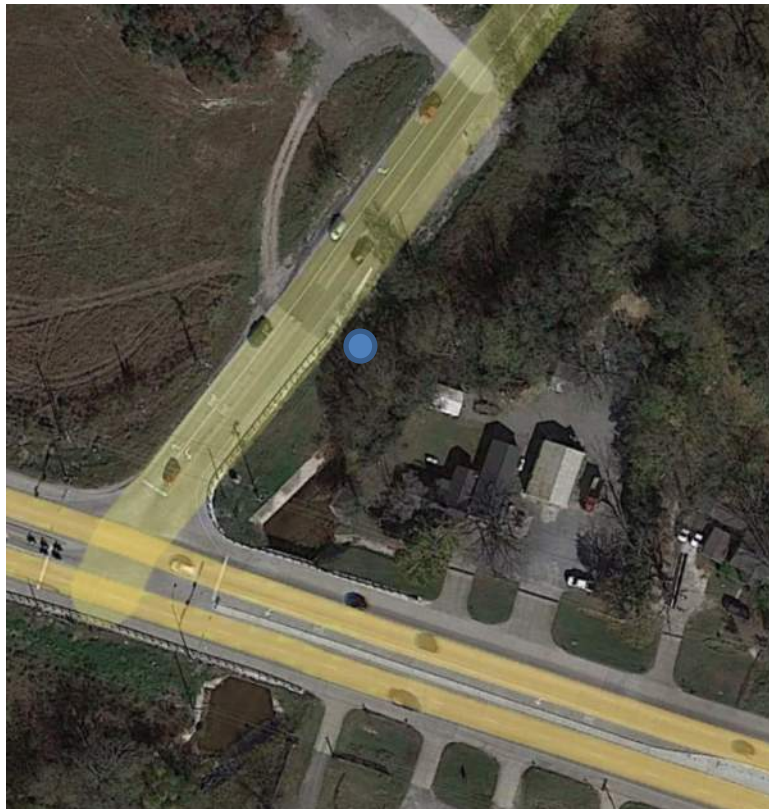
A

Lin.

Location Description: Location ML-14 – US 380

SITE SKETCH: Including noise source, receptors, reference distances, North arrow, wind direction arrow, terrain and shielding, roadway profile, and direct lines of sight:

SLM placed along US 380, ~160ft from edge of nearest travel lane ; 20 ft from New Hope Road.





Start Time:

4:19:42 AM **PM**

Stop Time:

4:48:42 AM **PM**

Duration:

30 minutes

Wind Speed/Direction: 9 mph N

Percentiles: _____

Temperature: 63-70 F

Humidity: 46% RH (partly cloudy)

Calibration results before: _____ 114.0 dBA and after _____ 114.0 dBA

Traffic Count Roadway: US 380 EB (Top Row) and WB (Bottom Row)

Autos	Medium Trucks	Heavy Trucks	Buses	Motorcycles
329 per 10 minutes	2 per 10 minutes	10 per 10 minutes	1 per 10 minutes	----
411 per 10 minutes	3 per 10 minutes	13 per 10 minutes	----	3 per 10 minutes

Combined traffic on New Hope Road: 44 auto NB; 46 auto / 7 med / 1 hvy / 4 motor SB over 10 minutes

***Note roadway direction in table**



SHORT-TERM TRAFFIC NOISE MONITORING LOG SHEET

PROJECT: 10226441 - BMCD US380 Spur399 SCH ENV

JOB NO.: 10226441

SITE/READING NO.: File 21

PERSONNEL: RMB

LOCATION/ADDRESS: Location ML-14

DATE: 12/16/2021

#	1 Minute Period Starting	Meas'd Leq (dBA)	v or X	Other Noise Sources	COMMENTS
1	16:19:42	69.6			
2	16:20:42	66.5			
3	16:21:42	68.1			Red light
4	16:22:42	67.4			Plane, green light
5	16:23:42	70.8			Red light
6	16:24:42	69.7			Green light
7	16:25:42	67.9			Red light
8	16:26:42	71.8			Green light
9	16:27:42	69.6			Green light
10	16:28:42	68.6			Red light
11	16:29:42	69.7			
12	16:30:42	67.2			
13	16:31:42	65.5			Red light
14	16:32:42	71.1			Green light
15	16:33:42	72.1			
16	16:34:42	69.3			Red light
17	16:35:42	68.2			Green light
18	16:36:42	69.4			Red light
19	16:37:42	69.6			Green light
20	16:38:42	67.0			
21	16:39:42	66.4			
22	16:40:42	68.5			
23	16:41:42	67.7			
24	16:42:42	66.1			
25	16:43:42	68.1			
26	16:44:42	70.6			
27	16:45:42	75.2			
28	16:46:42	67.3			Vehicle backfire
29	16:47:42	69.5			
30	16:48:42	71.1			

TOTAL Leq = 69.5 dBA

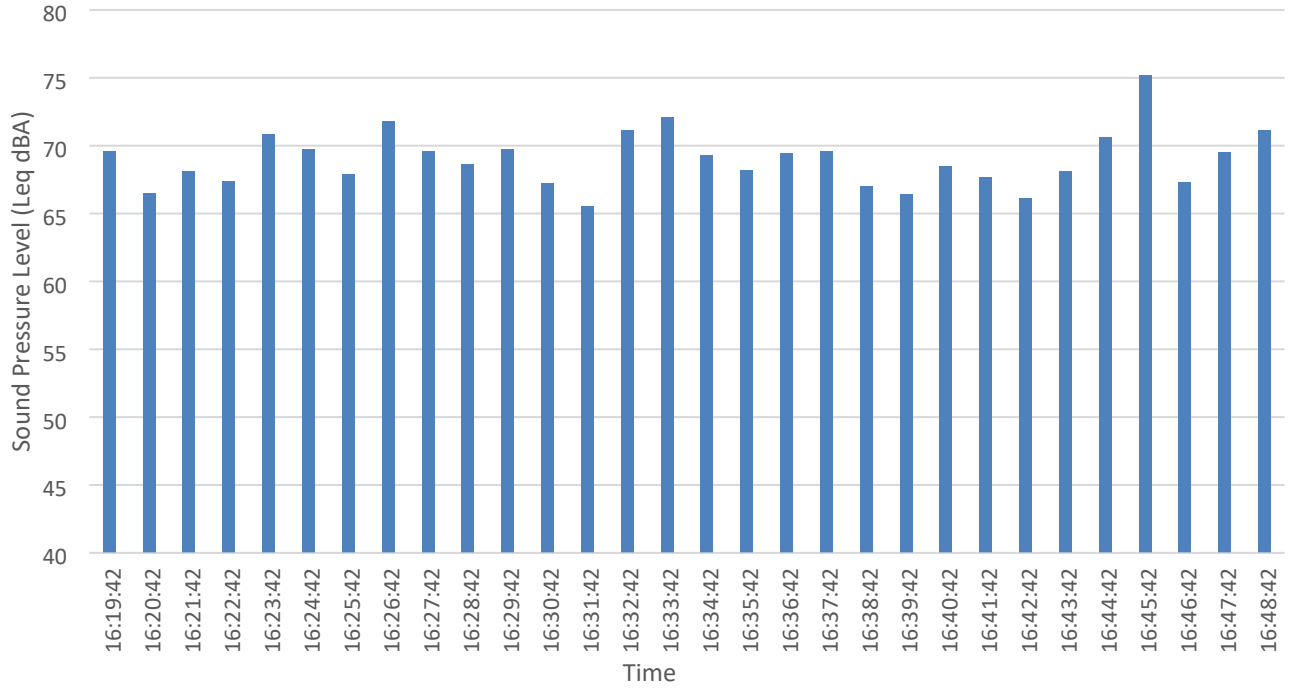
SUBSET Leq =

v = Other sources contributed to Leq X = Exclude period - contaminated by non-characteristic sources

>> ADD SKETCH AND WEATHER CONDITIONS TO REVERSE OR OTHER SHEET <<



Measured Sound Pressure Level ML-14





SHORT-TERM TRAFFIC NOISE MONITORING LOG SHEET

Reading: ML-15

Project Description: 10226441 - BMCD US380 Spur399 SCH ENV

Noise Source: TX 2933 Date: Dec. 16, 2021 Personnel: RMB

Equipment	Type	Serial #
Sound Level Meter	Larson Davis	824A2636
Microphone/Preamp	Larson Davis 2541; PRM902	7490
Calibrator	Larson Davis CAL200	2618

SLM SETTINGS (circle one)

FAST

SLOW

WEIGHTING (circle one)

A

Lin.

Location Description: Location ML-15 – TX 2933

SITE SKETCH: Including noise source, receptors, reference distances, North arrow, wind direction arrow, terrain and shielding, roadway profile, and direct lines of sight:

SLM placed along TX 2933, ~165ft from edge of nearest travel lane.





Start Time:

2:51:15 AM (PM)

Stop Time:

3:20:15 AM (PM)

Duration:

30 minutes

Wind Speed/Direction: 9 mph N

Percentiles: _____

Temperature: 63-70 F

Humidity: 46% RH (partly cloudy)

Calibration results before: _____ 114.0 dBA and after _____ 114.0 dBA

Traffic Count Roadway: TX 2933 SB (Top Row) and NB (Bottom Row)

Autos	Medium Trucks	Heavy Trucks	Buses	Motorcycles
25 per 30 minutes	2 per 30 minutes	3 per 30 minutes	2 per 30 minutes	----
23 per 30 minutes	1 per 30 minutes	5 per 30 minutes	----	----

***Note roadway direction in table**



SHORT-TERM TRAFFIC NOISE MONITORING LOG SHEET

PROJECT: 10226441 - BMCD US380 Spur399 SCH ENV
 JOB NO.: 10226441

SITE/READING NO.: File 19

PERSONNEL: RMB

LOCATION/ADDRESS: Location ML-15

DATE: 12/16/2021

#	1 Minute Period Starting	Meas'd Leq (dBA)	v or X	Other Noise Sources	COMMENTS
1	14:51:15	54.9			
2	14:52:15	49.6			
3	14:53:15	49.5			
4	14:54:15	45.3			
5	14:55:15	52.8			Plane
6	14:56:15	53.0			Overhead plane
7	14:57:15	68.1			Overhead plane
8	14:58:15	43.8			
9	14:59:15	55.2			
10	15:00:15	60.4			
11	15:01:15	53.8			
12	15:02:15	59.6			
13	15:03:15	56.2			Distant plane
14	15:04:15	58.1			
15	15:05:15	48.2			
16	15:06:15	43.4			Plane
17	15:07:15	59.9			
18	15:08:15	53.3			Distant plane
19	15:09:15	49.8			Distant plane
20	15:10:15	54.0			
21	15:11:15	45.8			Distant plane
22	15:12:15	56.4			
23	15:13:15	57.4			Plane
24	15:14:15	44.1			
25	15:15:15	54.4			
26	15:16:15	55.7			Distant jet
27	15:17:15	55.6			
28	15:18:15	54.8			Distant jet
29	15:19:15	53.8			Distant plane
30	15:20:15	58.0			

TOTAL Leq = 57.3 dBA

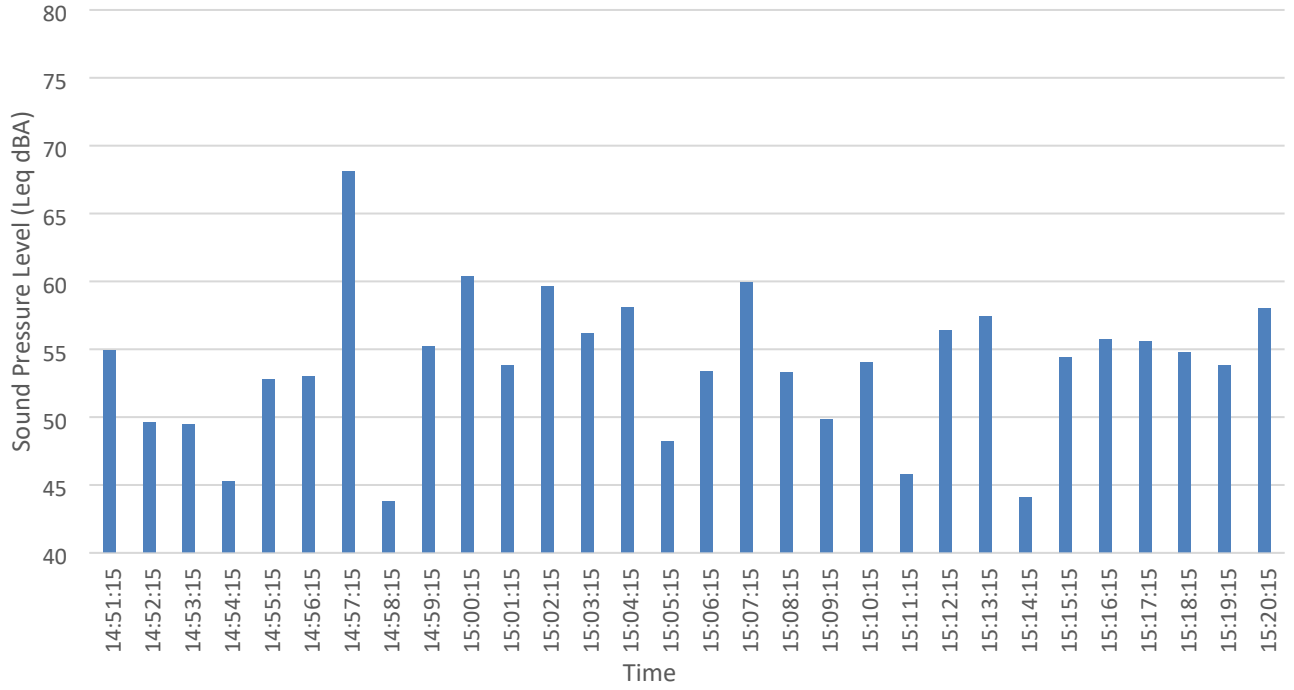
SUBSET Leq =

v = Other sources contributed to Leq X = Exclude period - contaminated by non-characteristic sources

>> ADD SKETCH AND WEATHER CONDITIONS TO REVERSE OR OTHER SHEET <<



Measured Sound Pressure Level ML-15





#	Southbound				Northbound			
	Auto	Med	Hvy	Motorcycle	Auto	Med	Hvy	Motorcycle
1	1	0	0		0	1	0	
2	0	0	0		1	0	0	
3	0	0	0		1	0	0	
4	0	0	0		0	0	0	
5	0	0	0		1	0	0	
6	1	0	0		0	0	0	
7	1	0	0		2	0	0	
8	0	0	0		0	0	0	
9	2	0	0		3	0	1	
10	3	0	0		1	0	0	
11	2	0	0		1	0	0	
12	2	1	0		0	0	0	
13	0	0	0		2	0	0	
14	2	0	0		0	0	0	
15	1	0	0		0	0	0	
16	1	0	0		0	0	2	
17	0	0	0		0	0	0	
18	1	0	0		1	0	0	
19	2	0	0		0	0	0	
20	0	0	0		1	0	0	
21	0	1	0		0	0	0	
22	0	0	1		2	0	0	
23	0	0	0		0	0	0	
24	0	0	1		1	0	0	
25	2	0	0		1	0	0	
26	1	0	0		2	0	0	
27	1	0	0		2	0	0	
28	0	0	0		0	0	0	
29	2	0	0		1	0	0	
30	0	0	1		0	0	2	



SHORT-TERM TRAFFIC NOISE MONITORING LOG SHEET

Reading: ML-17

Project Description: 10226441 - BMCD US380 Spur399 SCH ENV

Noise Source: US 75 Date: Dec. 16, 2021

Personnel: RMB

Equipment	Type	Serial #
Sound Level Meter	Larson Davis	824A2636
Microphone/Preamp	Larson Davis 2541; PRM902	7490
Calibrator	Larson Davis CAL200	2618

SLM SETTINGS (circle one)

FAST

SLOW

WEIGHTING (circle one)

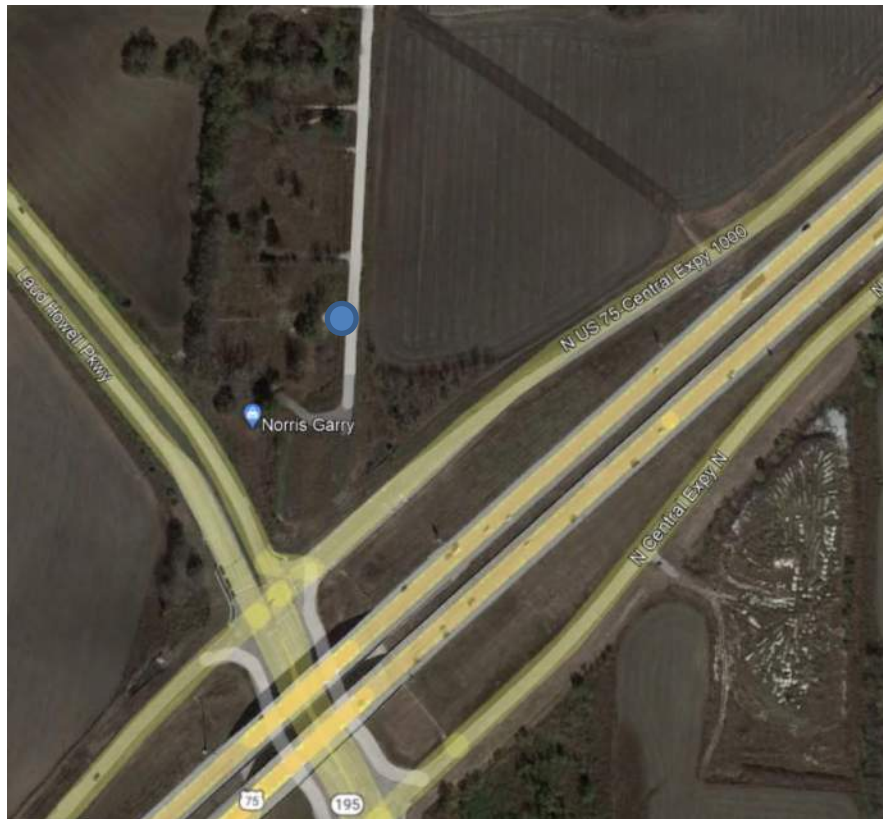
A

Lin.

Location Description: Location ML-17 – US 75

SITE SKETCH: Including noise source, receptors, reference distances, North arrow, wind direction arrow, terrain and shielding, roadway profile, and direct lines of sight:

SLM placed on west side of roadway, ~555ft from edge of nearest travel lane of US 75. Relatively poor line-of-site to traffic, especially to NB traffic.





Start Time:

10:15:00 AM PM

Stop Time:

10:44:00 AM PM

Duration:

30 minutes

Wind Speed/Direction: 11 mph SSW

Percentiles: _____

Temperature: 66-75 F

Humidity: 73% RH (partly sunny)

Calibration results before: _____ 114.0 dBA and after _____ 114.0 dBA

Traffic Count Roadway: US 75 SB (Top Row) and NB (Bottom Row)

Autos	Medium Trucks	Heavy Trucks	Buses	Motorcycles
845 per 15 minutes	9 per 15 minutes	85 per 15 minutes	----	----
681 per 15 minutes	4 per 15 minutes	98 per 15 minutes	----	----

***Note roadway direction in table**



SHORT-TERM TRAFFIC NOISE MONITORING LOG SHEET

PROJECT: 10226441 - BMCD US380 Spur399 SCH ENV
 JOB NO.: 10226441

SITE/READING NO.: File 14

PERSONNEL: RMB

LOCATION/ADDRESS: Location ML-17

DATE: 12/16/2021

#	1 Minute Period Starting	Meas'd Leq (dBA)	v or X	Other Noise Sources	COMMENTS
1	10:15:00	66.8			
2	10:16:00	68.9			
3	10:17:00	69.0			
4	10:18:00	66.5			
5	10:19:00	66.1			
6	10:20:00	67.6			
7	10:21:00	66.3			
8	10:22:00	68.1			
9	10:23:00	66.9			
10	10:24:00	66.9			
11	10:25:00	67.8			
12	10:26:00	67.3			
13	10:27:00	66.9			
14	10:28:00	68.2			
15	10:29:00	67.6			
16	10:30:00	68.4			
17	10:31:00	69.2			
18	10:32:00	67.1			
19	10:33:00	67.3			
20	10:34:00	61.4			
21	10:35:00	62.0			
22	10:36:00	61.4			
23	10:37:00	62.8			
24	10:38:00	61.1			
25	10:39:00	61.6			
26	10:40:00	62.4			
27	10:41:00	62.6			
28	10:42:00	61.9			
29	10:43:00	61.5			
30	10:44:00	62.6			

TOTAL Leq = 66.3 dBA

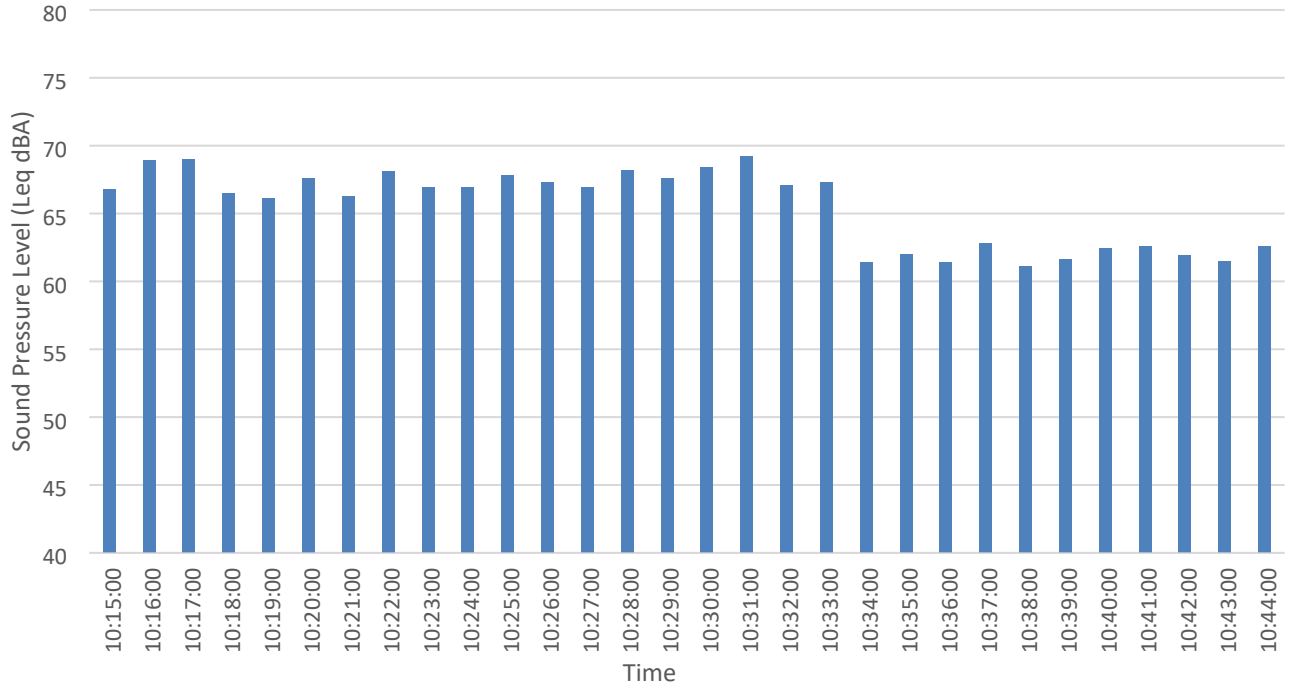
SUBSET Leq =

v = Other sources contributed to Leq X = Exclude period - contaminated by non-characteristic sources

>> ADD SKETCH AND WEATHER CONDITIONS TO REVERSE OR OTHER SHEET <<



Measured Sound Pressure Level ML-17





#	Southbound				Northbound			
	Auto	Med	Hvy	Motorcycle	Auto	Med	Hvy	Motorcycle
1	51	0	4					
2	65	0	8					
3	55	0	11					
4	42	0	4					
5	36	0	3					
6	64	1	3					
7	56	0	6					
8	72	1	5					
9	50	2	9					
10	50	0	5					
11	52	1	3					
12	50	2	5					
13	64	1	7					
14	78	0	7					
15	60	1	5					
16					37	0	13	
17					43	0	9	
18					35	0	9	
19					36	0	6	
20					40	0	7	
21					48	0	6	
22					34	0	3	
23					56	0	9	
24					58	1	10	
25					54	1	5	
26					50	0	5	
27					48	0	3	
28					52	1	7	
29					46	0	5	
30					44	1	1	



SHORT-TERM TRAFFIC NOISE MONITORING LOG SHEET

Reading: ML-18

Project Description: 10226441 - BMCD US380 Spur399 SCH ENV

Noise Source: US 75 Date: Dec. 16, 2021

Personnel: RMB

Equipment	Type	Serial #
Sound Level Meter	Larson Davis	824A2636
Microphone/Preamp	Larson Davis 2541; PRM902	7490
Calibrator	Larson Davis CAL200	2618

SLM SETTINGS (circle one)

FAST

SLOW

WEIGHTING (circle one)

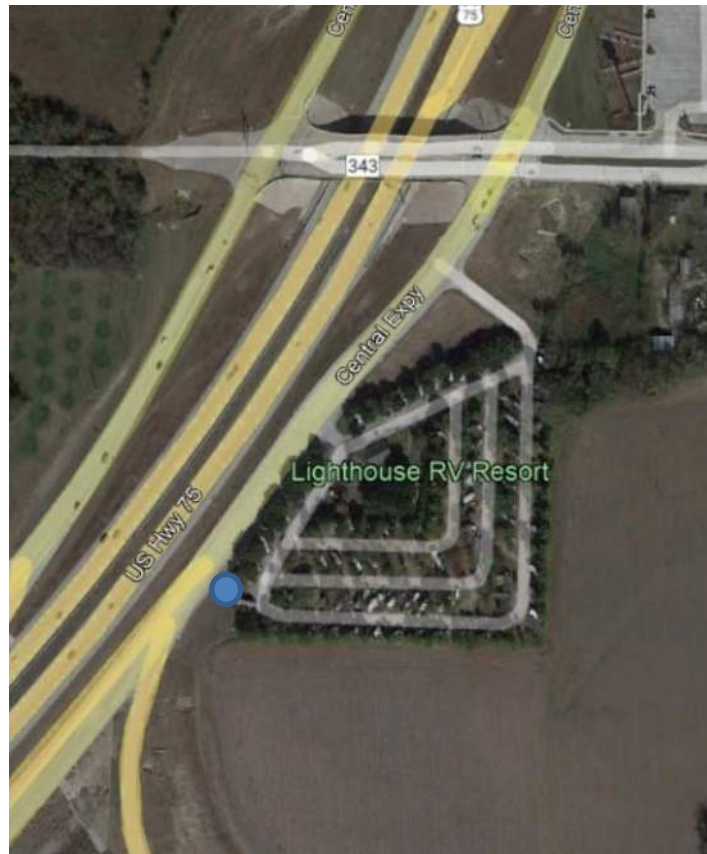
A

Lin.

Location Description: Location ML-18 – US 75

SITE SKETCH: Including noise source, receptors, reference distances, North arrow, wind direction arrow, terrain and shielding, roadway profile, and direct lines of sight:

SLM placed on east side of roadway at top of berm, ~150ft from edge of nearest NB travel lane of US 75. Relatively good line-of-site to traffic.





Start Time:

2:03:53 AM **PM**

Stop Time:

2:32:53 AM **PM**

Duration:

30 minutes

Wind Speed/Direction: 11 mph SSW

Percentiles: _____

Temperature: 66-75 F

Humidity: 73% RH (partly sunny)

Calibration results before: _____ 114.0 dBA and after _____ 114.0 dBA

Traffic Count Roadway: US 75 SB (Top Row) and NB (Bottom Row)

Autos	Medium Trucks	Heavy Trucks	Buses	Motorcycles
545 per 15 minutes	5 per 15 minutes	63 per 15 minutes	----	----
420 per 15 minutes	8 per 15 minutes	23 per 15 minutes	----	----

***Note roadway direction in table**



SHORT-TERM TRAFFIC NOISE MONITORING LOG SHEET

PROJECT: 10226441 - BMCD US380 Spur399 SCH ENV

JOB NO.: 10226441

SITE/READING NO.: File 15

PERSONNEL: RMB

LOCATION/ADDRESS: Location ML-18

DATE: 12/16/2021

#	1 Minute Period Starting	Meas'd Leq (dBA)	v or X	Other Noise Sources	COMMENTS
1	14:03:53	75.7			
2	14:04:53	75.1			
3	14:05:53	76.5			
4	14:06:53	75.7			
5	14:07:53	76.4			
6	14:08:53	75.6			
7	14:09:53	76.5			
8	14:10:53	76.3			
9	14:11:53	76.0			
10	14:12:53	76.1			
11	14:13:53	76.3			
12	14:14:53	76.5			
13	14:15:53	76.4			
14	14:16:53	76.9			
15	14:17:53	77.7			
16	14:18:53	75.9			
17	14:19:53	76.3			
18	14:20:53	74.8			
19	14:21:53	76.0			
20	14:22:53	75.8			
21	14:23:53	76.3			
22	14:24:53	76.6			
23	14:25:53	76.4			
24	14:26:53	76.5			
25	14:27:53	76.6			Wind
26	14:28:53	76.5			
27	14:29:53	78.6			Wind
28	14:30:53	77.8			Wind
29	14:31:53	76.4			Wind
30	14:32:53	77.3			

TOTAL Leq = 76.5 dBA

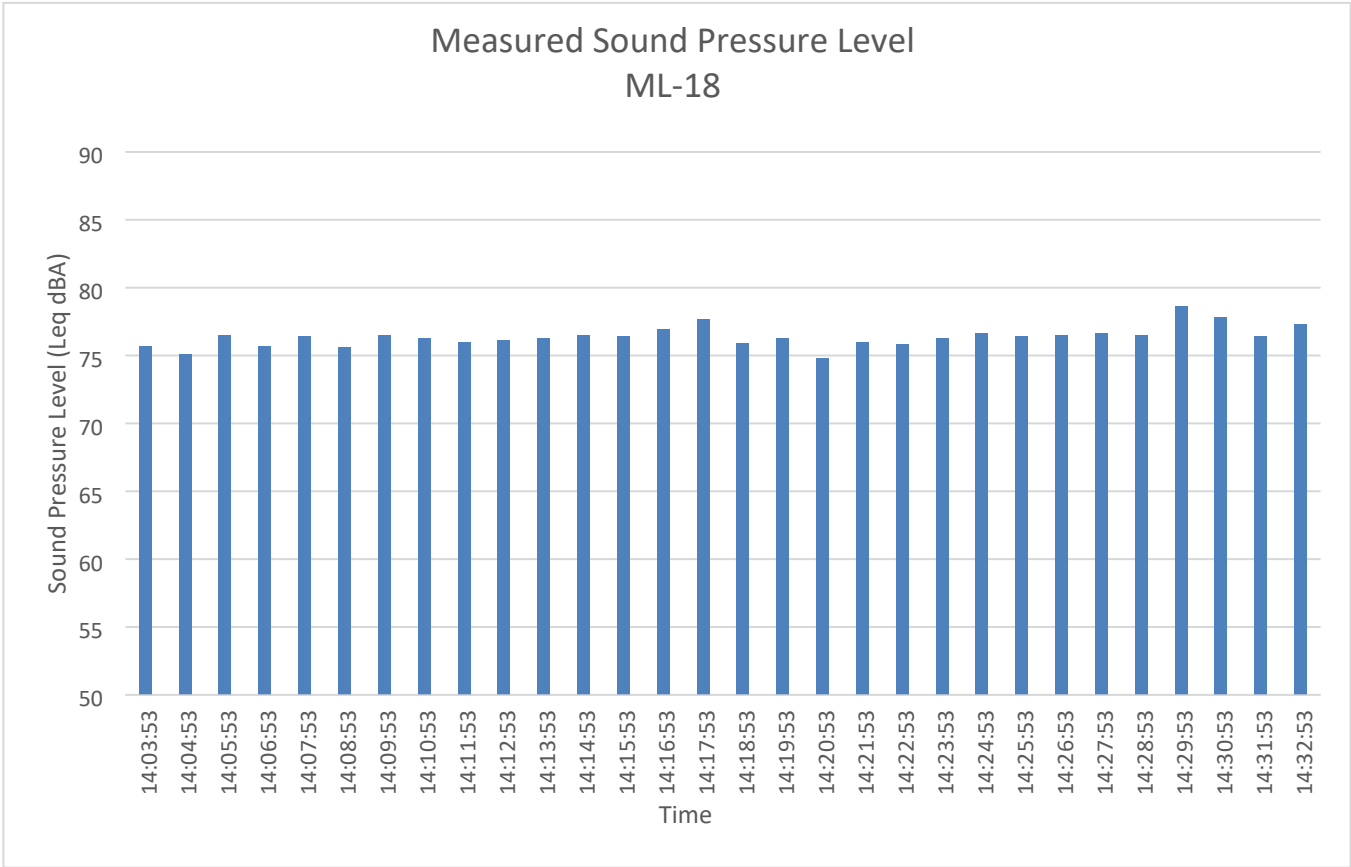
SUBSET Leq =

v = Other sources contributed to Leq

X = Exclude period - contaminated by non-characteristic sources



>> ADD SKETCH AND WEATHER CONDITIONS TO REVERSE OR OTHER SHEET <<





#	Southbound				Northbound			
	Auto	Med	Hvy	Motorcycle	Auto	Med	Hvy	Motorcycle
1					34	1	1	
2					26	0	2	
3					33	1	7	
4					21	0	4	
5					32	0	4	
6					32	1	3	
7					27	0	8	
8					25	1	8	
9					26	1	5	
10					21	0	4	
11					27	1	5	
12					28	1	5	
13					23	0	4	
14					39	1	4	
15					26	0	9	
16	34	0	6					
17	32	0	3					
18	41	0	2					
19	28	0	6					
20	33	0	6					
21	38	0	6					
22	47	1	5					
23	34	0	4					
24	36	0	4					
25	65	1	3					
26	34	0	5					
27	25	1	3					
28	33	0	3					
29	38	1	4					
30	27	1	3					

Attachment D – Ambient Noise Measurement

Additionally, background noise measurements were taken at five locations, as listed in **Table D-1** below. These measurements were performed during the same measurement timeframe and under the same conditions as described for the traffic noise measurements above.

Table D-1. Background Levels dB(A) Leq

Location	Measurement Site	Field-Measured Level dB(A) Leq
ML-7	Nature Nate Farms Rd.	46.6
ML-8	TX 124	43.8
ML-10	Hardin Blvd.	51.6
ML-12	Woodlawn Rd.	50.2
ML-16	TX 338	52.4



SHORT-TERM TRAFFIC NOISE MONITORING LOG SHEET

Reading: ML-7

Project Description: 10226441 - BMCD US380 Spur399 SCH ENV

Noise Source: Background Noise Date: Dec. 14, 2021 Personnel: RMB

Equipment	Type	Serial #
Sound Level Meter	Larson Davis	824A2636
Microphone/Preamp	Larson Davis 2541; PRM902	7490
Calibrator	Larson Davis CAL200	2618

SLM SETTINGS (circle one)

FAST

SLOW

WEIGHTING (circle one)

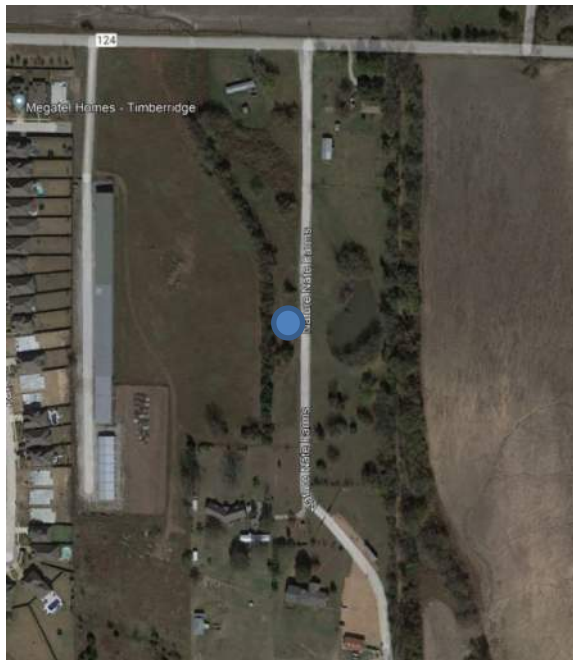
A

Lin.

Location Description: Location ML-7

SITE SKETCH: Including noise source, receptors, reference distances, North arrow, wind direction arrow, terrain and shielding, roadway profile, and direct lines of sight:

SLM placed along Nature Nate Farms Road (~5ft from roadway). Limited traffic ; SLM paused for vehicle pass-bys. Ambient noise sources include: distant aircraft, distant traffic, birds, leaves, distant construction back-up beepers, insects.





Start Time:

Stop Time:

Duration:

2:40:06 AM **PM**

3:10:00 AM **PM**

30 minutes

Wind Speed/Direction: 11 mph SSE

Percentiles: _____

Temperature: 66-70 F

Humidity: 90% RH (Partly cloudy)

Calibration results before: _____114.2 dBA and after _____114.1 dBA

Traffic Count Roadway: Background Noise

Autos	Medium Trucks	Heavy Trucks	Buses	Motorcycles

***Note roadway direction in table**



SHORT-TERM TRAFFIC NOISE MONITORING LOG SHEET

PROJECT: 10226441 - BMCD US380 Spur399 SCH ENV
 JOB NO.: 10226441

SITE/READING NO.: File 10

PERSONNEL: RMB

LOCATION/ADDRESS: Location ML-7

DATE: 12/14/2021

#	1 Minute Period Starting	Meas'd Leq (dBA)	v or X	Other Noise Sources	COMMENTS
1	14:40:06	44.3			
2	14:41:06	48.9			
3	14:42:06	45.0			Wind
4	14:43:06	49.0			Distant motorbike
5	14:44:06	50.0			
6	14:45:06	45.8			
7	14:46:06	46.5			Wind / distant aircraft
8	14:47:06	48.6			Wind
9	14:49:00	45.7			Wind
10	14:50:00	47.8			
11	14:51:00	48.8			
12	14:52:00	47.3			
13	14:53:00	45.9			
14	14:54:00	46.5			
15	14:55:00	45.1			
16	14:56:00	44.3			
17	14:57:00	44.5			
18	14:58:00	43.7			
19	14:59:00	43.6			
20	15:00:00	43.1			Horn
21	15:01:00	46.5			Wind
22	15:02:00	45.6			Plane
23	15:03:00	44.8			
24	15:04:00	47.6			
25	15:05:00	50.7			
26	15:06:00	44.0			
27	15:07:00	46.3			Plane
28	15:08:00	43.5			
29	15:09:00	47.4			
30	15:10:00	46.0			

TOTAL Leq = 46.6 dBA

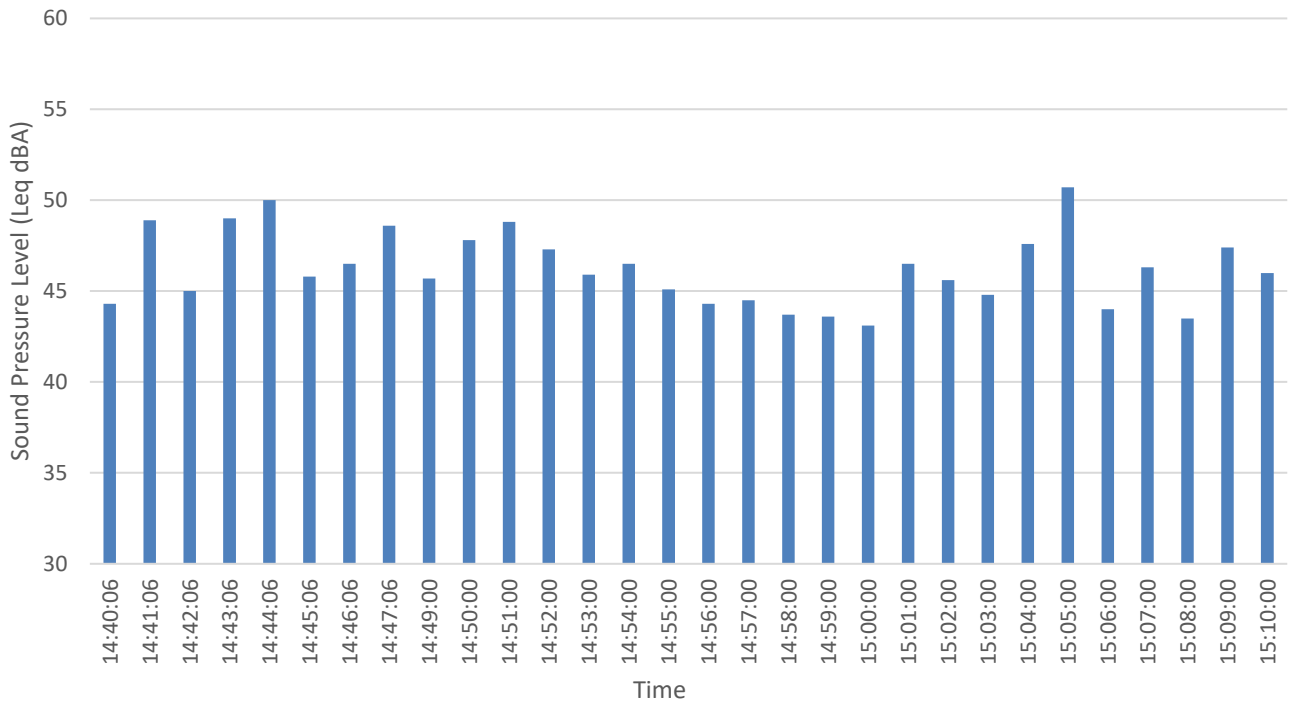
SUBSET Leq =

v = Other sources contributed to Leq X = Exclude period - contaminated by non-characteristic sources

>> ADD SKETCH AND WEATHER CONDITIONS TO REVERSE OR OTHER SHEET <<



Measured Sound Pressure Level ML-7





SHORT-TERM TRAFFIC NOISE MONITORING LOG SHEET

Reading: ML-8

Project Description: 10226441 - BMCD US380 Spur399 SCH ENV

Noise Source: Background Noise Date: Dec. 14, 2021 Personnel: RMB

Equipment	Type	Serial #
Sound Level Meter	Larson Davis	824A2636
Microphone/Preamp	Larson Davis 2541; PRM902	7490
Calibrator	Larson Davis CAL200	2618

SLM SETTINGS (circle one)

FAST

SLOW

WEIGHTING (circle one)

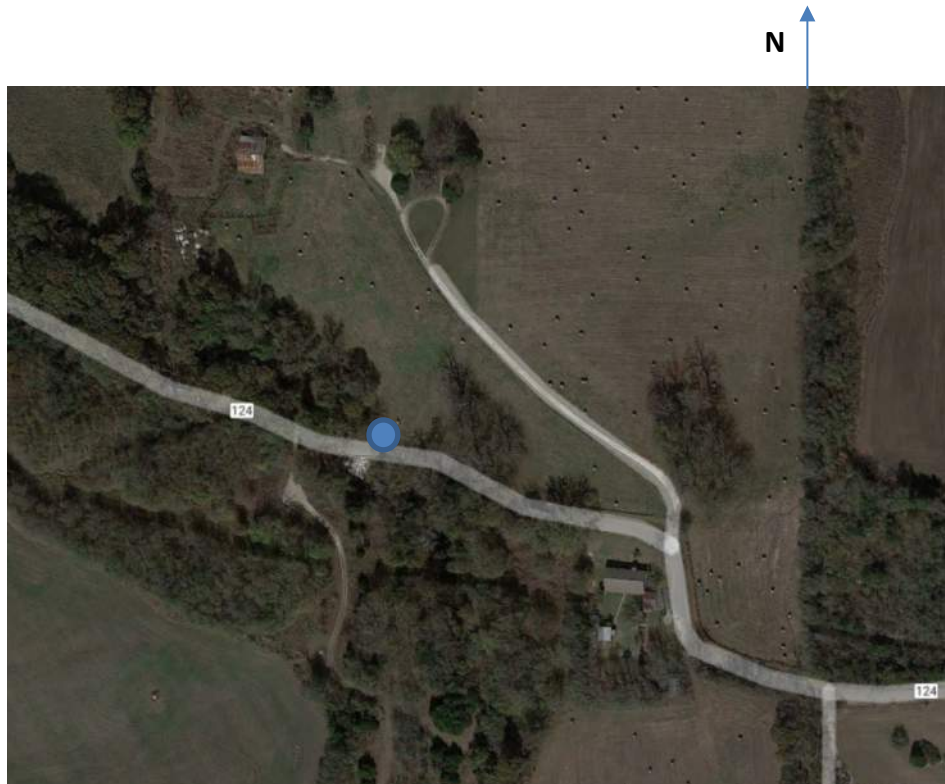
A

Lin.

Location Description: Location ML-8

SITE SKETCH: Including noise source, receptors, reference distances, North arrow, wind direction arrow, terrain and shielding, roadway profile, and direct lines of sight:

SLM placed along TX 124 (~5ft from roadway). Limited traffic. Typical ambient 40-43 dBA. Some noted vehicle pass-bys of 65-70 dBA included in measurements due to proximity of measurement location to roadway (remove for representative background noise – 15 minutes sufficient for this purpose). Ambient noise sources include : creek, leaves, insects, distant construction, distant equipment beepers, birds, very distant aircraft.





Start Time:

1:57:13AM **PM**

Stop Time:

2:26:13 AM **PM**

Duration:

30 minutes

Wind Speed/Direction: 11 mph SSE

Percentiles: _____

Temperature: 66-70 F

Humidity: 90% RH (Partly cloudy)

Calibration results before: _____ 114.2 dBA and after _____ 114.1 dBA

Traffic Count Roadway:

Autos	Medium Trucks	Heavy Trucks	Buses	Motorcycles

***Note roadway direction in table**



SHORT-TERM TRAFFIC NOISE MONITORING LOG SHEET

PROJECT: 10226441 - BMCD US380 Spur399 SCH ENV

JOB NO.: 10226441

SITE/READING NO.: File 9

PERSONNEL: RMB

LOCATION/ADDRESS: Location ML-8

DATE: 12/14/2021

#	1 Minute Period Starting	Meas'd Leq (dBA)	v or X	Other Noise Sources	COMMENTS
1	13:57:13	58.5			Car pass-by
2	13:58:13	41.6			
3	13:59:13	42.8			Distant motorbike
4	14:00:13	41.3			
5	14:01:13	59.4			
6	14:02:13	45.2			Car pass-by
7	14:03:13	43.4			
8	14:04:13	40.7			
9	14:05:13	40.7			
10	14:06:13	40.9			
11	14:07:13	41.3			
12	14:08:13	59.7			Car pass-by
13	14:09:13	42.6			
14	14:10:13	62.1			Car pass-by (2x)
15	14:11:13	41.9			
16	14:12:13	58.1			Car pass-by
17	14:13:13	67.4			Car pass-by (2x)
18	14:14:13	58.0			Car pass-by
19	14:15:13	43.0			
20	14:16:13	44.5			
21	14:17:13	50.3			Car pass-by
22	14:18:13	56.7			
23	14:19:13	43.5			
24	14:20:13	43.3			
25	14:21:13	62.0			Car pass-by (2x)
26	14:22:13	65.5			Car pass-by (2x)
27	14:23:13	53.9			Wind
28	14:24:13	57.3			Car pass-by
29	14:25:13	43.1			
30	14:26:13	43.8			

TOTAL Leq = 57.7 dBA

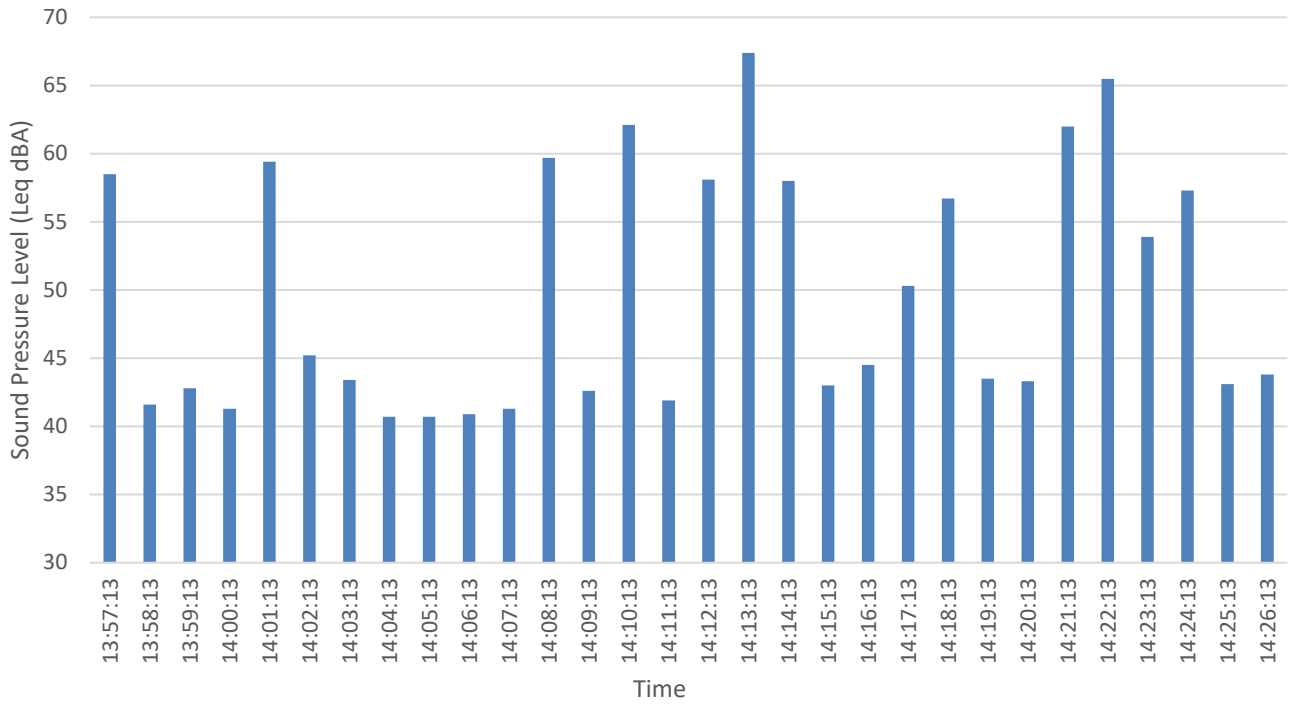
SUBSET Leq = 43.8 dBA

v = Other sources contributed to Leq X = Exclude period - contaminated by non-characteristic sources

>> ADD SKETCH AND WEATHER CONDITIONS TO REVERSE OR OTHER SHEET <<



Measured Sound Pressure Level ML-8





SHORT-TERM TRAFFIC NOISE MONITORING LOG SHEET

Reading: ML-10

Project Description: 10226441 - BMCD US380 Spur399 SCH ENV

Noise Source: Background Noise Date: Dec. 16, 2021 Personnel: RMB

Equipment	Type	Serial #
Sound Level Meter	Larson Davis	824A2636
Microphone/Preamplifier	Larson Davis 2541; PRM902	7490
Calibrator	Larson Davis CAL200	2618

SLM SETTINGS (circle one)

FAST

SLOW

WEIGHTING (circle one)

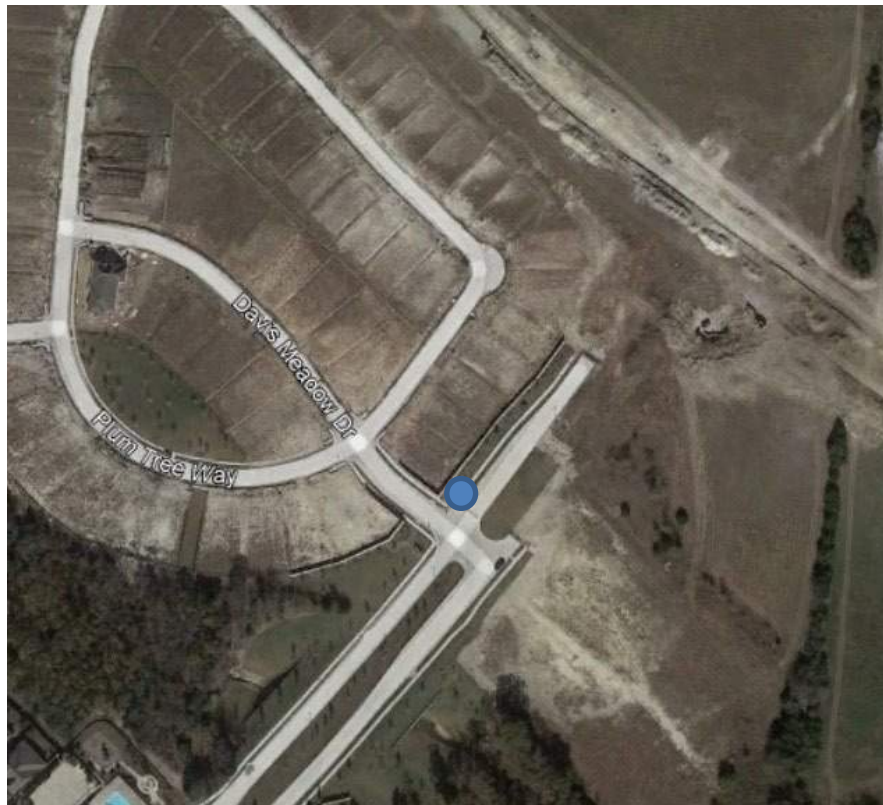
A

Lin.

Location Description: Location ML-10 – Background Noise

SITE SKETCH: Including noise source, receptors, reference distances, North arrow, wind direction arrow, terrain and shielding, roadway profile, and direct lines of sight:

SLM placed at end of Hardin Blvd. Typical noise sources included distant residential construction, distant aircraft, distant heavy equipment, birds, distant traffic, back-up beepers. Typical ambient in 40 dBA range.





Start Time:

9:25:45 (AM) PM

Stop Time:

9:54:45 (AM) PM

Duration:

30 minutes

Wind Speed/Direction: 11 mph SSW

Percentiles: _____

Temperature: 66-75 F

Humidity: 73% RH (partly sunny)

Calibration results before: _____ 114.0 dBA and after _____ 114.0 dBA

Traffic Count Roadway:

Autos	Medium Trucks	Heavy Trucks	Buses	Motorcycles

***Note roadway direction in table**



SHORT-TERM TRAFFIC NOISE MONITORING LOG SHEET

PROJECT: 10226441 - BMCD US380 Spur399 SCH ENV

JOB NO.: 10226441

SITE/READING NO.: File 13

PERSONNEL: RMB

LOCATION/ADDRESS: Location ML-10

DATE: 12/16/2021

#	1 Minute Period Starting	Meas'd Leq (dBA)	v or X	Other Noise Sources	COMMENTS
1	9:25:45	46.1			Hammering – residential construction
2	9:26:45	46.5			
3	9:27:45	46.4			
4	9:28:45	48.5			
5	9:29:45	51.7			
6	9:30:45	46.8			Car passby
7	9:31:45	46.2			Car passby
8	9:32:45	51.8			
9	9:33:45	50.0			
10	9:34:45	51.8			Car passby
11	9:35:45	55.4			
12	9:36:45	56.6			Car passby
13	9:37:45	52.1			Car passby
14	9:38:45	52.3			Car passby
15	9:39:45	47.3			Compressor on
16	9:40:45	47.3			Compressor on
17	9:41:45	47.9			
18	9:42:45	53.8			Compressor on – off
19	9:43:45	53.6			Compressor on – off
20	9:44:45	55.9			
21	9:45:45	54.1			Plane
22	9:46:45	46.6			Compressor on – off, car passby (3x)
23	9:47:45	52.3			Compressor on - off
24	9:48:45	50.9			
25	9:49:45	51.6			
26	9:50:45	76.9	X		Siren
27	9:51:45	73.1	X		Siren
28	9:52:45	70.4	X		Siren off
29	9:53:45	47.2			
30	9:54:45	48.6			Plane

TOTAL Leq = 64.5 dBA

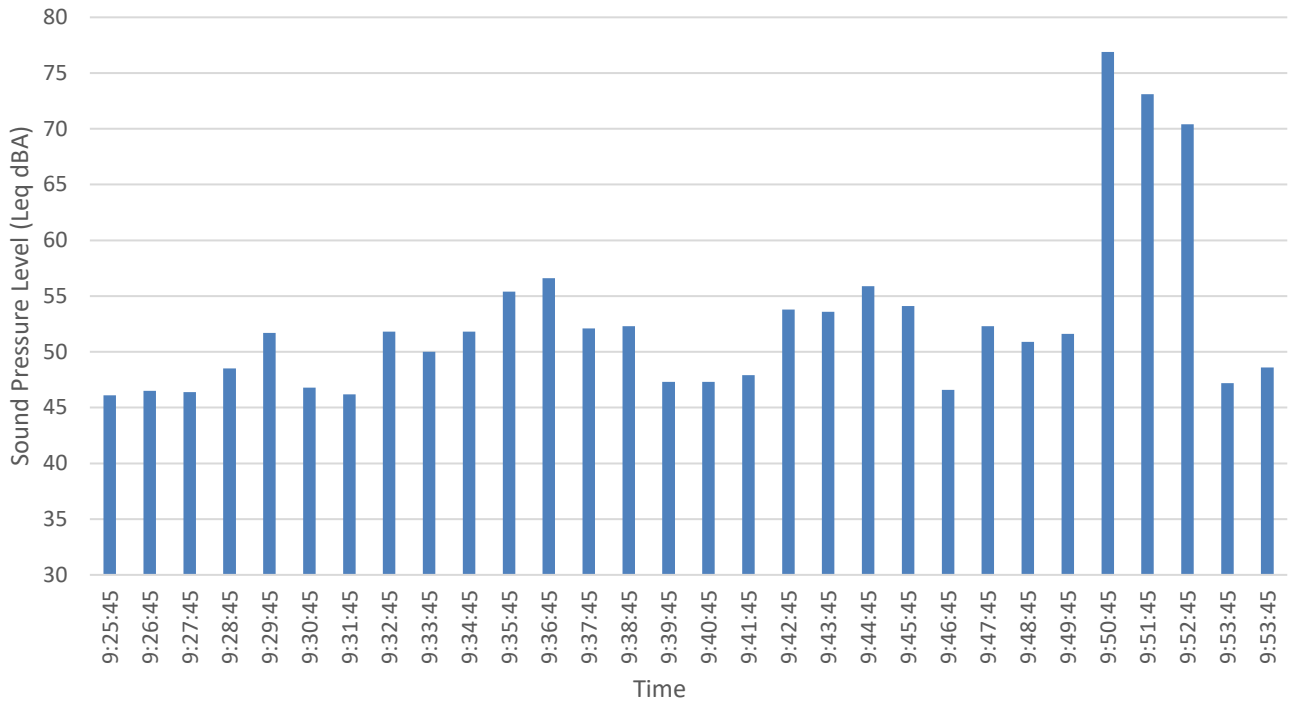
SUBSET Leq = 51.6 dBA

v = Other sources contributed to Leq X = Exclude period - contaminated by non-characteristic sources

>> ADD SKETCH AND WEATHER CONDITIONS TO REVERSE OR OTHER SHEET <<



Measured Sound Pressure Level ML-10





SHORT-TERM TRAFFIC NOISE MONITORING LOG SHEET

Reading: ML-12

Project Description: 10226441 - BMCD US380 Spur399 SCH ENV

Noise Source: Background Noise Date: Dec. 16, 2021 Personnel: RMB

Equipment	Type	Serial #
Sound Level Meter	Larson Davis	824A2636
Microphone/Preamp	Larson Davis 2541; PRM902	7490
Calibrator	Larson Davis CAL200	2618

SLM SETTINGS (circle one)

FAST

SLOW

WEIGHTING (circle one)

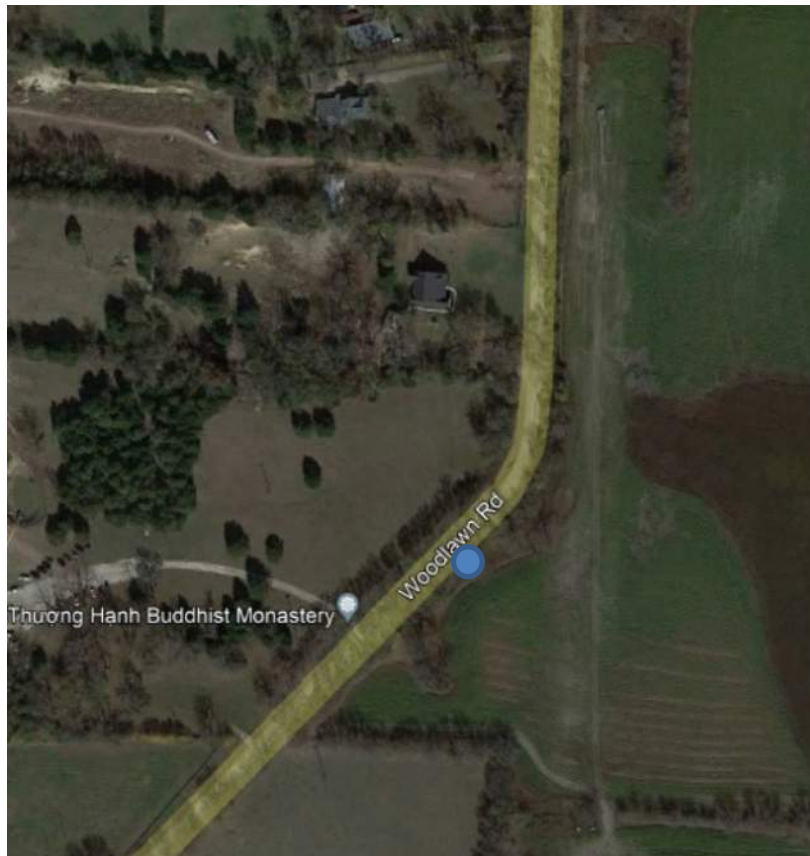
A

Lin.

Location Description: Location ML-12 – Background Noise

SITE SKETCH: Including noise source, receptors, reference distances, North arrow, wind direction arrow, terrain and shielding, roadway profile, and direct lines of sight:

SLM placed along Woodlawn. Meter paused for vehicle pass-bys. Typical noise sources included birds, small aircraft, distant traffic, and leaves. Typical ambient in 43-46 dBA range.





Start Time:

12:33:41 AM **PM**

Stop Time:

1:10:41 AM **PM**

Duration:

30 minutes

Wind Speed/Direction: 9 mph N

Percentiles: _____

Temperature: 63-70 F

Humidity: 46% RH (partly cloudy)

Calibration results before: _____ 114.0 dBA and after _____ 114.0 dBA

Traffic Count Roadway:

Autos	Medium Trucks	Heavy Trucks	Buses	Motorcycles

***Note roadway direction in table**



SHORT-TERM TRAFFIC NOISE MONITORING LOG SHEET

PROJECT: 10226441 - BMCD US380 Spur399 SCH ENV

JOB NO.: 10226441

SITE/READING NO.: File 16

PERSONNEL: RMB

LOCATION/ADDRESS: Location ML-12

DATE: 12/16/2021

#	1 Minute Period Starting	Meas'd Leq (dBA)	v or X	Other Noise Sources	COMMENTS
1	12:31:41	51.5			Small plane
2	12:35:41	46.4			
3	12:37:41	53.6			
4	12:38:41	49.2			Plane
5	12:38:41	46.4			Small plane
6	12:40:41	52.0			jet
7	12:41:41	48.1			
8	12:42:41	48.5			
9	12:43:41	46.2			Distant small plane
10	12:44:41	48.5			Distant small plane
11	12:45:41	48.3			
12	12:47:41	48.7			
13	12:48:41	44.4			Small plane
14	12:49:41	46.7			
15	12:51:41	50.2			Plane
16	12:52:41	50.9			
17	12:54:41	57.0			
18	12:55:41	48.4			
19	12:56:41	46.4			
20	12:57:41	51.5			Plane
21	12:58:41	49.8			
22	13:00:41	47.7			
23	13:01:41	51.5			Plane
24	13:02:41	51.4			
25	13:03:41	53.4			Distant plane
26	13:04:41	48.3			
27	13:06:41	49.9			
28	13:07:41	48.4			
29	13:08:41	49.3			
30	13:09:41	44.9			

TOTAL Leq = 50.2 dBA

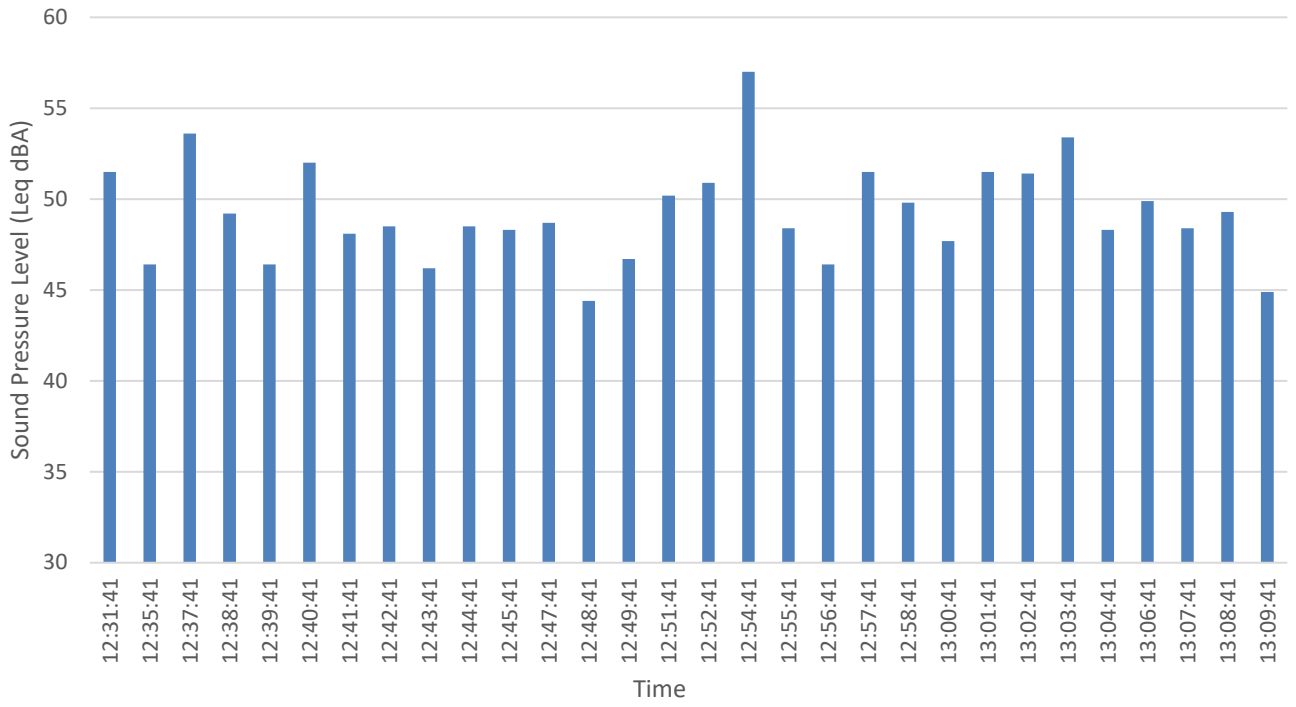
SUBSET Leq =

v = Other sources contributed to Leq X = Exclude period - contaminated by non-characteristic sources

>> ADD SKETCH AND WEATHER CONDITIONS TO REVERSE OR OTHER SHEET <<



Measured Sound Pressure Level ML-12





SHORT-TERM TRAFFIC NOISE MONITORING LOG SHEET

Reading: ML-16

Project Description: 10226441 - BMCD US380 Spur399 SCH ENV

Noise Source: Background Noise Date: Dec. 16, 2021 Personnel: RMB

Equipment	Type	Serial #
Sound Level Meter	Larson Davis	824A2636
Microphone/Preamp	Larson Davis 2541; PRM902	7490
Calibrator	Larson Davis CAL200	2618

SLM SETTINGS (circle one)

FAST

SLOW

WEIGHTING (circle one)

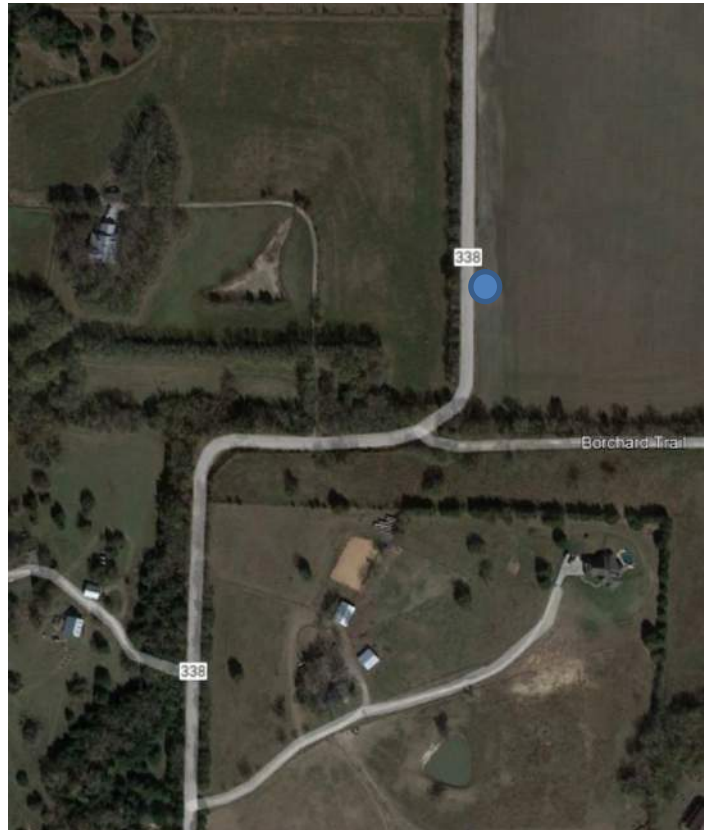
A

Lin.

Location Description: Location ML-16 – Background Noise

SITE SKETCH: Including noise source, receptors, reference distances, North arrow, wind direction arrow, terrain and shielding, roadway profile, and direct lines of sight:

SLM placed along TX 338. Meter paused for vehicle pass-bys. Typical noise sources included birds, small aircraft, distant traffic, and leaves. Typical ambient in 43-45 dBA range.





Start Time:

1:37:48 AM **PM**

Stop Time:

2:06:48 AM **PM**

Duration:

30 minutes

Wind Speed/Direction: 9 mph N

Percentiles: _____

Temperature: 63-70 F

Humidity: 46% RH (partly cloudy)

Calibration results before: _____ 114.0 dBA and after _____ 114.0 dBA

Traffic Count Roadway:

Autos	Medium Trucks	Heavy Trucks	Buses	Motorcycles

***Note roadway direction in table**



SHORT-TERM TRAFFIC NOISE MONITORING LOG SHEET

PROJECT: 10226441 - BMCD US380 Spur399 SCH ENV

JOB NO.: 10226441

SITE/READING NO.: File 17

PERSONNEL: RMB

LOCATION/ADDRESS: Location ML-16

DATE: 12/16/2021

#	1 Minute Period Starting	Meas'd Leq (dBA)	v or X	Other Noise Sources	COMMENTS
1	13:37:48	44.3			
2	13:38:48	44.2			Plane
3	13:39:48	44.7			
4	13:40:48	44.0			Plane
5	13:41:48	44.7			
6	13:42:48	47.1			
7	13:43:48	45.1			
8	13:44:48	42.8			
9	13:45:48	44.2			
10	13:46:48	46.6			Plane
11	13:47:48	49.3			Plane
12	13:48:48	45.1			
13	13:49:48	44.9			
14	13:50:48	44.7			
15	13:51:48	43.2			
16	13:52:48	43.6			
17	13:53:48	43.2			
18	13:54:48	42.9			
19	13:55:48	43.7			
20	13:56:48	65.4			Overhead plane
21	13:57:48	47.0			
22	13:58:48	45.8			Nearby plane / nearby car
23	13:59:48	46.3			
24	14:00:48	51.5			
25	14:01:48	42.1			
26	14:02:48	41.2			
27	14:03:48	43.6			
28	14:04:48	42.2			
29	14:05:48	59.1			Overhead jet
30	14:06:48	45.1			

TOTAL Leq = 52.4 dBA

SUBSET Leq =

v = Other sources contributed to Leq X = Exclude period - contaminated by non-characteristic sources

>> ADD SKETCH AND WEATHER CONDITIONS TO REVERSE OR OTHER SHEET <<



Measured Sound Pressure Level ML-16

